

<b>Document Title</b>	Explanation of Application Interfaces of Occupant and Pedestrian Safety Systems Domain
<b>Document Owner</b>	AUTOSAR
<b>Document Responsibility</b>	AUTOSAR
<b>Document Identification No</b>	271

<b>Document Status</b>	Final
<b>Part of AUTOSAR Standard</b>	Classic Platform
<b>Part of Standard Release</b>	4.3.1

<b>Document Change History</b>			
<b>Date</b>	<b>Release</b>	<b>Changed by</b>	<b>Change Description</b>
2017-12-08	4.3.1	AUTOSAR Release Management	<ul style="list-style-type: none"> <li>Editorial changes</li> </ul>
2016-11-30	4.3.0	AUTOSAR Release Management	<ul style="list-style-type: none"> <li>Editorial changes</li> </ul>
2014-10-31	4.2.1	AUTOSAR Release Management	<ul style="list-style-type: none"> <li>Editorial changes</li> </ul>
2013-03-15	4.1.1	AUTOSAR Administration	<ul style="list-style-type: none"> <li>Added Crash Status (SWCo 003 CS)</li> <li>Added Roll- and Pitch- over Crash Detection (SWCo's 302 ROD, 303 POD)</li> <li>Updated coordinate reference system with roll and pitch polarities.</li> </ul>
2010-09-30	3.1.5	AUTOSAR Administration	<ul style="list-style-type: none"> <li>Corrected location of paragraph related to Sensor Safety Requirements to be in Sensor Pool chapter</li> </ul>
2010-02-02	3.1.4	AUTOSAR Administration	<ul style="list-style-type: none"> <li>Initial release</li> </ul>

## Disclaimer

This work (specification and/or software implementation) and the material contained in it, as released by AUTOSAR, is for the purpose of information only. AUTOSAR and the companies that have contributed to it shall not be liable for any use of the work.

The material contained in this work is protected by copyright and other types of intellectual property rights. The commercial exploitation of the material contained in this work requires a license to such intellectual property rights.

This work may be utilized or reproduced without any modification, in any form or by any means, for informational purposes only. For any other purpose, no part of the work may be utilized or reproduced, in any form or by any means, without permission in writing from the publisher.

The work has been developed for automotive applications only. It has neither been developed, nor tested for non-automotive applications.

The word AUTOSAR and the AUTOSAR logo are registered trademarks.

## Table of Contents

1	Purpose of this Document .....	4
1.1	References .....	4
2	Description of Terms and Concepts.....	4
2.1	List of terms and abbreviations .....	4
2.2	Introduction into domain “Occupant and Pedestrian Safety” .....	5
2.3	OPS Phases (Event Timeline) .....	5
2.3.1	Pre-Crash Phase .....	5
2.3.2	Post-Crash Phases:.....	6
2.4	Domain Modeling.....	7
2.5	Reference System .....	8
2.5.1	Reference Coordinate System.....	8
2.5.2	Naming convention for Seat Positions .....	9
3	Architecture Overview.....	11
3.1	Variant Handling .....	12
4	Description of Software Compositions and Components.....	13
4.1	Sensor Pool (SWCo 001 SP).....	13
4.2	Actuator Pool (SWCo 002 AP).....	15
4.3	Crash Status (SWCo 003 CS) .....	17
4.4	Seat Belt Reminder (SWCo 102 SBR).....	18
4.4.1	SWC Seat Belt Reminder Calculation.....	19
4.4.2	SWC Seat Belt Reminder Belt State.....	19
4.4.3	SWC Seat Belt Reminder Warn Control .....	19
4.5	Vehicle Crash Detection (SWCo 301 VCD) .....	20
4.6	Roll- and Pitch- over Crash Detection (SWCo’s 302 ROD, 303 POD).....	22
4.7	Occupant Restraint System Activation (SWCo 304 ORA) .....	22
4.8	Pedestrian Protection Crash Detection (SWCo 305 PCD).....	23
4.9	Pedestrian Protection System Activation (SWCo 306 PPA) .....	23
4.10	Occupant Detection (SWCo 101 OD) .....	24
5	Additional Information .....	25
5.1	Detailed Explanation of the Sensor Pool Port Names.....	25
5.2	Detailed Explanation of the Actuator Pool Port Names.....	26

## 1 Purpose of this Document

This document provides background information such as design decisions that lead to the Application Interfaces definition standardized for the domain "Occupant and Pedestrian Safety Systems".

### 1.1 References

- [1] AUTOSAR Table of Application Interface AUTOSAR\_MOD\_AITable
- [2] AUTOSAR\_TPS\_GenericStructureTemplate.pdf chapter 12

## 2 Description of Terms and Concepts

### 2.1 List of terms and abbreviations

AB	Airbag
AI	Application Interface
COOP	Critical Out of Position
eCall	Emergency Call
HMI	Human Machine Interface
IF	Interface
OD	Occupant Detection
OOP	Out Of Position
OPS	Occupant and Pedestrian Safety
OPSS	OPS Systems
ORA	Occupant Restraint Activation
PCD	Pedestrian Crash Detection
PPA	Pedestrian Protection Actuator Activation
SBR	Seat Belt Reminder
SRS	Safety Restraint System
SWC	Software Component
SWCo	Software Composition
VCD	Vehicle Crash Detection
ROD	Rollover Crash Detection
POD	Pitchover Crash Detection
Antisubmarine	Term used in restraint systems for automotive applications related to an AB that upon deployment prevents a front row passenger from diving below the dashboard by lifting the person's lower body. Thus, the person is brought into a better position relative to the main Front AB
VH	Variant Handling concept
SP	Sensor Pool
AP	Actuator Pool
CS	Crash Status
ACC	Adaptive Cruise Control
RSM	Restraint System Monitoring
VCP	Vehicle Crash Prediction
PCP	Pedestrian Crash Prediction
OPC	Occupant Pre Conditioning
RSP	Restraint System Pre conditioning
PPP	Pedestrian Protection system Pre conditioning
VCD	Vehicle Crash Detection
PCI	Post Crash Information

## 2.2 Introduction into domain “Occupant and Pedestrian Safety”

The field of Occupant and Pedestrian Safety aims at protecting both vehicle occupants as well as pedestrians in the eventuality of a crash. In this sense, "crash" is a rather broad term used to categorized situations in which the vehicle is either colliding with an obstacle (frontally, laterally, rear), or with a pedestrian frontally or even against the ground, as an example in case of a rollover situation.

The notion of "crash" or "accident" shapes the scope of OPS making it an event driven domain. For example, the event of a vehicle side collision with a light pole would trigger an SRS to deploy a lateral airbag to prevent the occupant being hit by a vehicle structure, like a door or the C-Pillar, which is under deformation due to the struck. The event oriented nature of OPS systems make it suitable to model the domain as a chain of phases, each of which is entered after a determined event is triggered. The timeline in the next section aims at providing a graphical representation of the main OPS phases and their corresponding events.

## 2.3 OPS Phases (Event Timeline)

Figure 1 shows a time line where the most important OPS phases are summarized. A Sensor Signal curve is used representatively to depict different crash phases. Each of the OPS phases is modelled as consisting of two sub-phases which provide further detail about the vehicle situation regarding to a crash event situation.

This OPS phases are available for other domains to know in which phase of the event the vehicle is. A simple Post-Crash / Pre-crash classification is generally sufficient for other domains, however a more refine definition was proposed into previous version of Explanatory document.

Figure 1 provides the correspondances between thoses two definitions.

### 2.3.1 Pre-Crash Phase

The pre-Crash phases can be divided into more refined sub-phases:

#### **Normal Driving:**

The Vehicle is in a condition with ignition ON (either in still stand or moving) and there is a very low probability of a crash. Sub-phases are:

- Normal driving: in this sub-state no significant probability of crash has been detected
- Normal driving with small risk of crash: in this sub-state there is a small probability for crash, but still the vehicle contact-based crash sensors have not detected the event. In this phase a minimum of crash risk is present, an example would be situations where a vehicle Stability Control mechanism is actuating.

#### **Pre-Crash:**

The Vehicle is in a situation out of normal driving conditions, where there exists an indication that the probability of a crash is greater than a certain threshold. Reversible actuators are activated usually in this phase e.g. to bring occupants into a correct seating position for optimal protection by SRS in case of a following crash. Sub-phases are:

- Still avoidable crash: a pre-crash system has detected a hazard of collision but still evaluates a chance for avoiding a crash, e.g. by means of a haptic warning, emergency braking or evasive maneuvers, among others.
- Non-avoidable crash: a pre-crash system concludes that given the current dynamics of the vehicle and its environment, that a collision cannot be avoided anymore.

**In-Crash: Undetermined collision**

For Front, Side, Pedestrian and Rear, this phase starts with the first contact of the vehicle with an obstacle, for example another vehicle, or a Vulnerable Road User, for example a pedestrian. For the special case of Rollover and Pitchover, In-Crash is entered after having reached a definite threshold, e.g. inclination angle. In the In-Crash Undetermined collision, the on board crash contact sensors measure activity but it is still too early to conclude about what type of situation the vehicle is in, e.g. in a so called "misuse" situation like a rough road drive, or in a collision with a rigid object.

**2.3.2 Post-Crash Phases:****In-Crash: Determined collision**

In the In-Crash Determined collision situation usually the non-reversible actuators are activated. A crash event is further categorized according to its severity, which can range from light (e.g. activate the belt retractor) up to high (e.g. activate second stage of an airbag).

**Post-Crash:**

This state is entered after an In-Crash situation that will be followed by:

- Return to normal driving conditions in case of light severity In-Crash events, thus providing the opportunity to handle multiple crash events
- Reaching Stand Still after an In-Crash situation
- After Restraint actuators have been activated

Sub-phases:

- Post-deployment: first actions are taken after a crash situation has been confirmed. Example actions could be the automatic unlocking of the vehicle doors
- Post-crash: the vehicle has reached again stand still, thus place Emergency Call

**Occupant & Pedestrian Safety Systems**  
**Topic: Event Timeline**

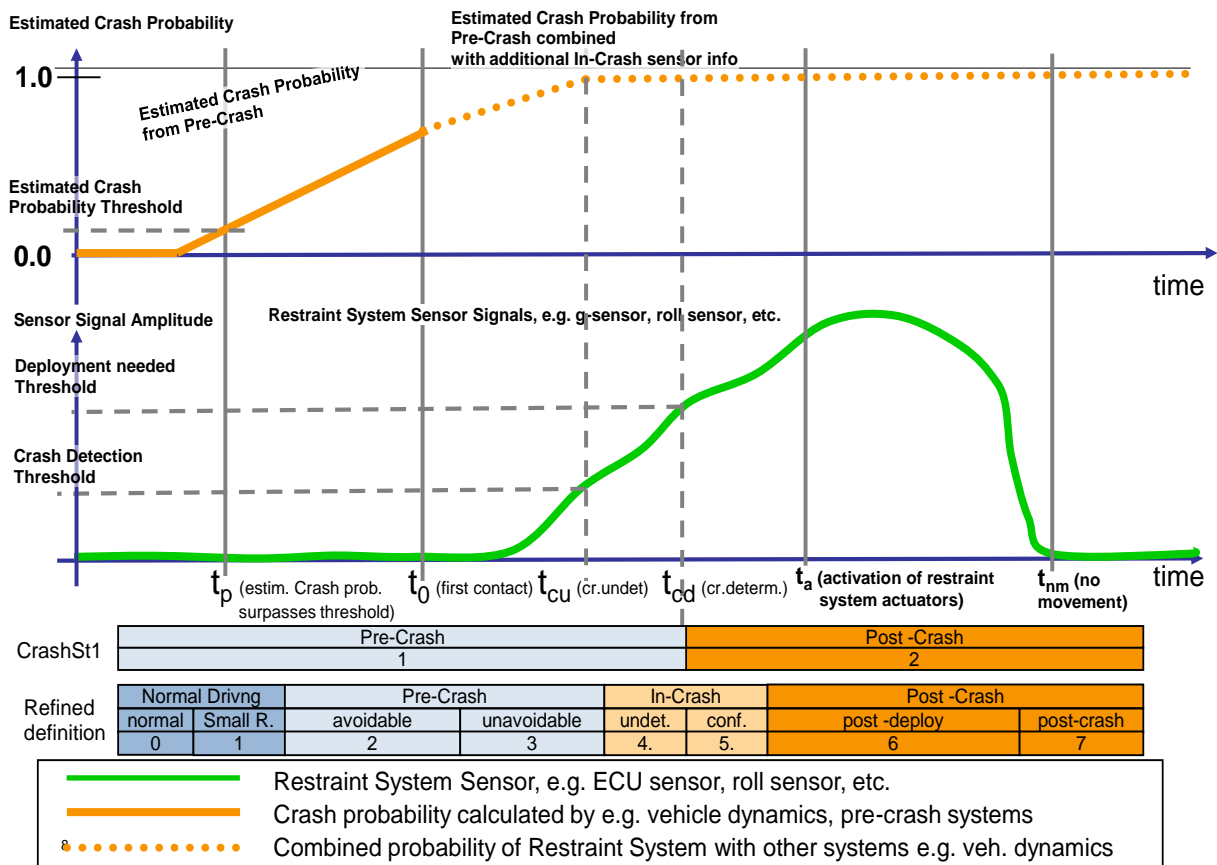

Figure 1. OPSS Phases

**2.4 Domain Modeling**

The scope of the present domain at hand is limited to the Passive Safety Functions. Other functions, like those from Driver Assistance systems e.g. ACC or Active Safety systems like ESC are part of Chassis domain and not included here. However, information provided from those systems can be used within the OPSS domain.

Figure 2 provides a graphical representation of the OPSS Domain. The Domain Model takes into account on the one hand the event-driven nature as depicted in Figure 1 as well as the AUTOSAR categorization for SW Components "Application" (named here "Function"), "Sensor" and "Actuator".

**Occupant & Pedestrian Safety Systems**  
**Topic: Proposal Domain Model**

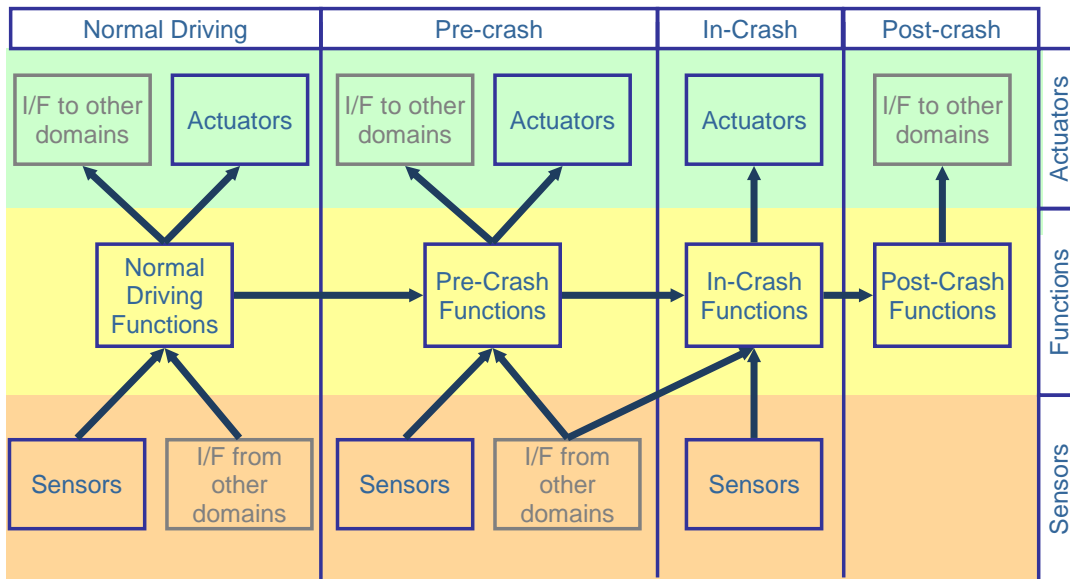

Legend:  
- I/F : interface

**Figure 2. OPSS Domain Model**

**2.5 Reference System**

In order to ensure consistent interpretation of the Interface Elements for the OPSS Domain, a series of state of the art reference systems have been adopted. Following is a short summary of them.

**2.5.1 Reference Coordinate System**

The coordinate reference system used in the OPSS is shown in Figure 3:



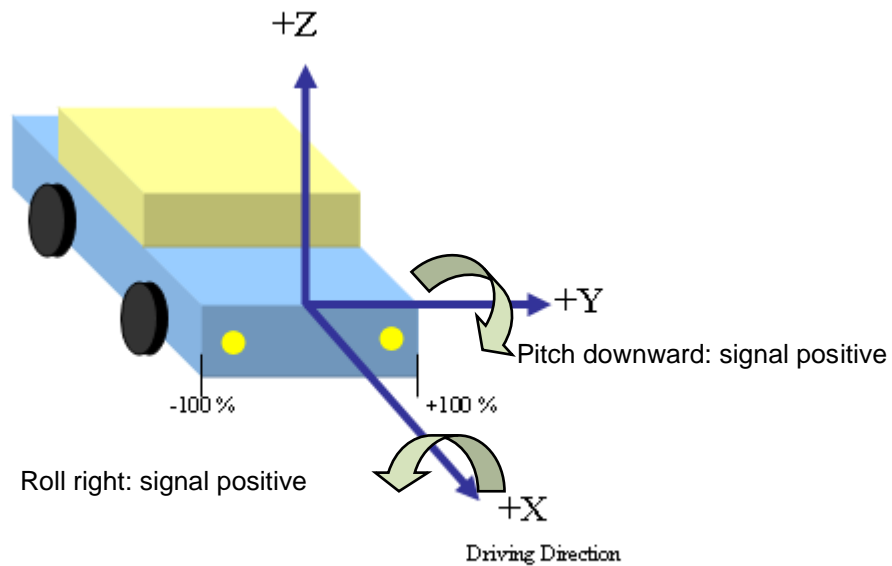

**Figure 3. Coordinate Reference System for OPSS**

This Coordinate Reference System is of relative nature, as opposed to alternative fixed-point Coordinate Systems, like a Center of Gravity-based system. For OPS domain, the primary relevance is the ability to determine in the first place the direction of vehicle deformation, while on the second place its corresponding severity. For example, the direction of vehicle deformation in a Front Crash event would determine that the possible Restraint System Actuators to get activated are only the Belt Retractors and Airbags; while the severity of the impact, which can be measured in terms of vehicle deformation, would determine which concrete Belt Retractors and / or Airbags should be deployed.

### 2.5.2 Naming convention for Seat Positions

For the naming of the seat positions, e.g. for the purpose of the Seat Belt Reminder function, or for the interpretation of the Actuator Positions in the vehicle, the reference system depicted in Figure 4 has been adopted. The convention provides for a unique naming of the second and third seat rows in the vehicle, but allows some flexibility in the naming of the first row. The flexibility for the first row is required in the OPS Domain, as important functionalities are often to be coupled to the Driver or Passenger Side, and should always stay consistent with the corresponding occupant position in Right or Left Steering vehicles, like e.g. driver specific actuators; while other functionalities might be dependent on an absolute vehicle side, i.e. left or right, regardless of a vehicle being Right or Left Steering.

**Occupant & Pedestrian Safety Systems**  
**Topic: Reference System for Occupant Seating Positions**

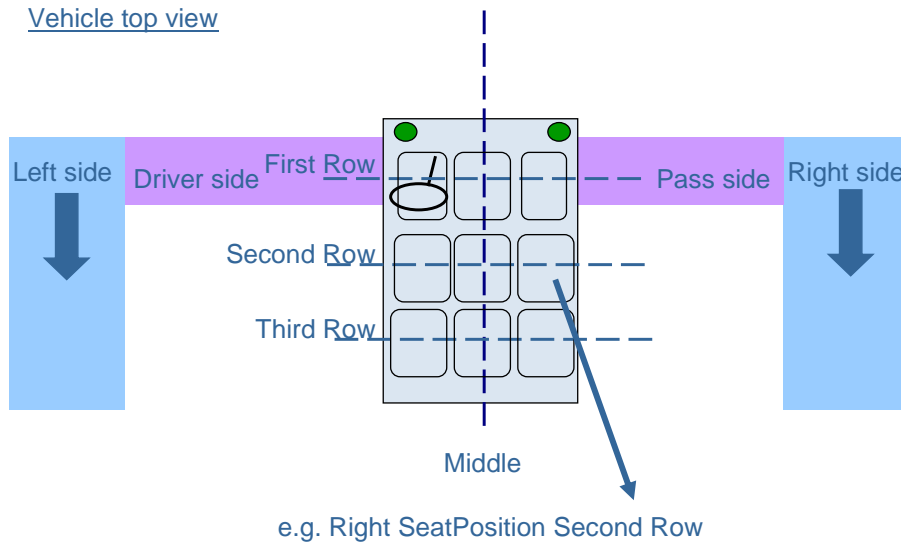

13

**Figure 4. Reference System for naming of Occupant Seating Positions in the vehicle**

### 3 Architecture Overview

In order to standardize Application Interfaces, the OPS Domain Model has been split into exemplary SW Compositions, following the principles as detailed above Figure 1).

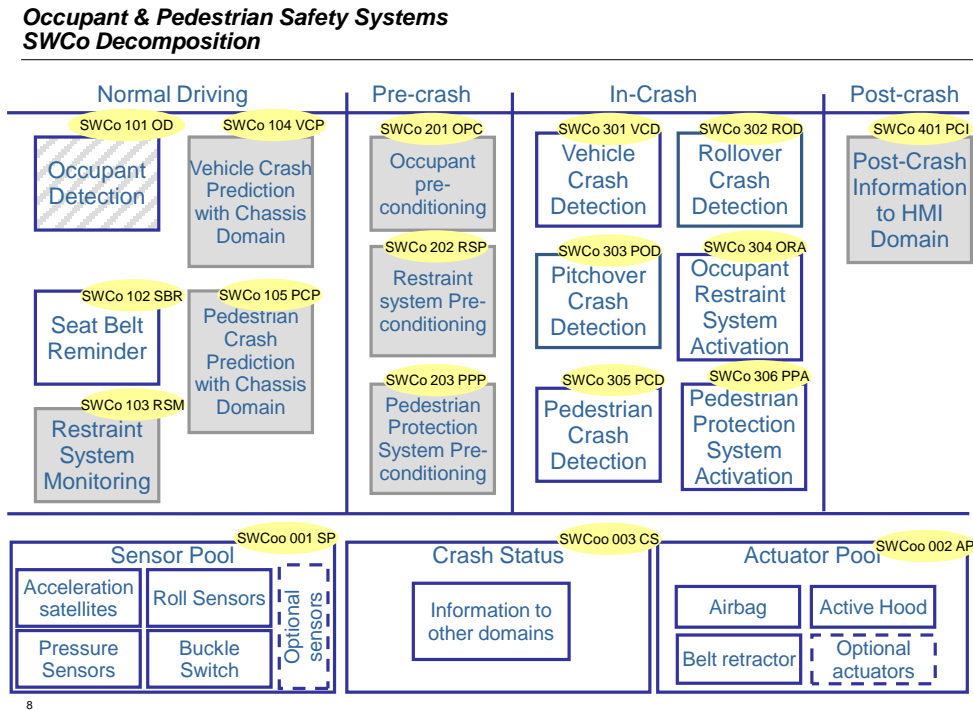

**Figure 5. OPSS SWCo Decomposition (Exemplary)**

The SW Compositions from Figure 5 can be interconnected among each other as well as with other AUTOSAR Domains (e.g. Chassis Domain). An overview of these connections is depicted in Figure 6. The SWCo's with grey background are not included in the current standardization, but will be standardized in the future. A special case is the Occupant Detection SWCo, where some interfaces are already defined within this release while others will be standardized in the future.

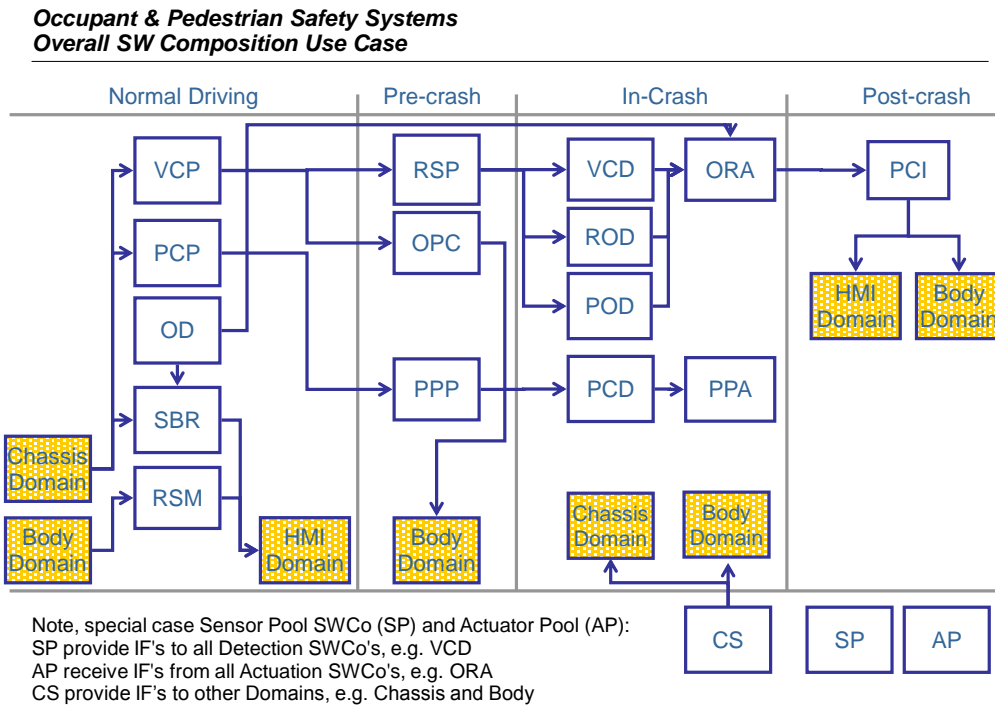

**Figure 6. Overall SW Composition and Interaction with other Domains**

### 3.1 Variant Handling

The OPS Autosar IF's as explained in this document represent the most typical applications of state of the art restraint systems. This does not imply that any OPS system implementing Autosar IF's will have exactly the same IF blueprint as any other system. In the practice there will be many variants reflecting the requirements posed to the implementation of the particular restraint system. In order to handle these variants, the Autosar metamodel provides a modelling concept that makes it feasible to model such diversity in the interface elements. Please refer to [2] for more information.

For OPS systems there are no fixed variants for the current release, but this might be extended or implemented in the future.

## 4 Description of Software Compositions and Components

Following is a detailed view of the SWCo depicted on Figure 5.

### 4.1 Sensor Pool (SWCo 001 SP)

The OPS Domain implements its detection function based on state of the art sensing technologies for the In-Crash functions and advanced sensing for the Normal Driving and Pre-Crash functions.

For In-Crash functions, the sensor technologies and its potential locations can be seen on Figure 7. The location naming adopted is valid for both left and right side steering wheel vehicles.

- **Peripheral Acceleration Sensors**  
-> front left/middle/right, rear left/middle/right
- **Acceleration Sensors in Front Bumper**  
-> left, mid left, middle, mid right and right
- **Acceleration Sensors in Doors**  
-> front door left/right, back door left/right
- ■ ■ **Acceleration Sensors in A -, B - and C- Pillar**  
-> A-/B-/C- Pillar left/right
- ● ● **Central Acceleration Sensors**  
-> longitudinal / lateral / upwards
- ● **Central Yaw-/ Roll-/Pitch Rate Sensors**  
-> Yaw Rate ( $\omega_Z$ ), Central Roll Rate( $\omega_X$ ), Central Pitch Rate ( $\omega_Y$ )
- **Pressure Sensors in Doors**  
-> front door left/right, back door left/right
- **Temperature Sensors**  
-> front bumper temperature

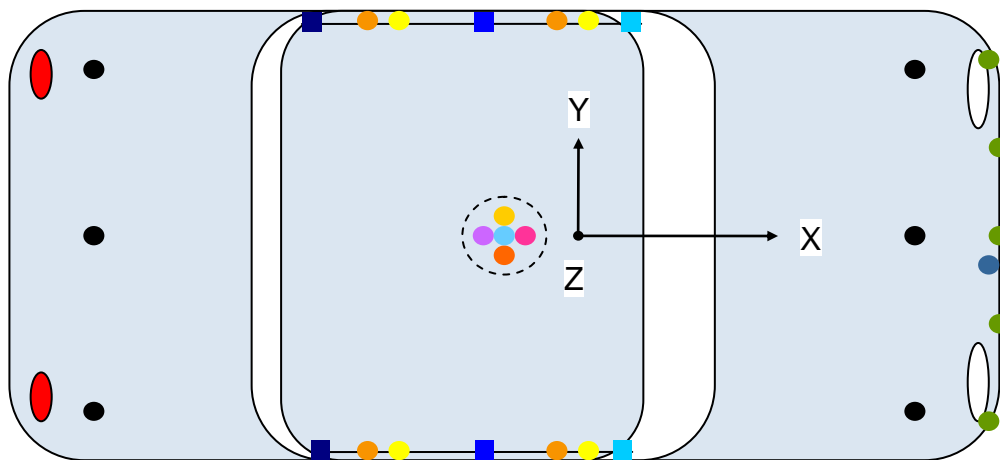

X...Longitudinal (Driving Direction), Y...Lateral, Z...Upwards

**Figure 7. Sensor Location in the vehicle for In-Crash functions.**

The Sensors are modelled as SWC's that belong to a Sensor Pool SW-Composition. For acceleration measuring sensors, following groups can be identified for standardization:

- Acceleration Internal: this is a group of sensors built-in into a Control Unit located typically in a well protected position in the interior of the vehicle, e.g. the vehicle tunnel (please refer to Figure 7).
  - Acceleration Low Range: typical measuring range around +/-10g
  - Acceleration Mid Range: typical measuring range around +/-100g
  - Acceleration Central: this is the default type of sensors, with a typical measuring range around +/-200 g.
- Acceleration External: this is the group of sensors mounted in the periphery of the vehicle. They can be either mono axial or biaxial, e.g. longitudinal and lateral measurement, or only longitudinal or only lateral. Due to their exposure to the surroundings of the car, these sensors are characterized by much higher measuring range than the internal sensors, for example, +/-800 g.

The sensor data, both for the external and internal ranges can be either raw values or filtered values, depending on the application.

The SWC's of the Sensor Pool Composition can also be categorized according to their sensing technology. In principle any Sensor SWC in the OPSS Domain belongs uniquely to one of the following sensor types:

- 1) Acceleration: the sensor SWC's in this category measure the deceleration of the vehicle structure in the event of a vehicle crash event, along a defined axis (e.g. vehicle X-axis). The sensors can be mounting at different locations in the car, e.g. in the tunnel, on the vehicle Front-End, on the B-Pillar, among others. For a complete description please refer to 5.1
- 2) Pressure: the sensor SWC's in this category measure the differential pressure caused by the intrusion and/or deformation of a cavity section in the vehicle structure, most typical is the door cavity space. Typical measuring range is from -50 ‰ ..+150 ‰. For a complete description please refer to 5.1
- 3) Temperature: the sensor SWC's in this category measure the environment or material temperature at a defined location in the vehicle. Typical mounting position for this sensor is the vehicle Front-End, where the sensor measures a local temperature that can be used as input e.g. for a Pedestrian Protection Crash Detection function (please refer to 4.8). For a complete description please refer to 5.1
- 4) Buckle state: the sensor SWC's in this category detect the state of the Safety Belts in the different seating positions in the vehicle to determine their Buckle State. Depending on the state, a SBR SWC can decide to provide a safety warning to the vehicle passengers to alert about this state (please refer to 4.4). For a complete description please refer to 5.1
- 5) Rotation: the sensor SWC's in this category measure the rotation rate of the vehicle along a defined axis (e.g. roll rate rotation over the X-axis). Typical mounting position for this sensor is the vehicle Center of Gravity. For a complete description please refer to 5.1

For a detailed description of the Sensor SWC's modelled in the AI Table (see [1]) please refer to 5.1. Please refer to the "Sensor Type" column in order to uniquely identify any Sensor SWC's listed in 5.1.

### 4.2 Actuator Pool (SWCo 002 AP)

Actuators are restraint means aimed at either absorbing crash energy or limiting the free motion of the person during crash events. Depending on the functionality of the SWC, there will be different actuators employed. For example, for Pedestrian Protection, the actuators are external to the vehicle and take the form of airbags or other deformable elements, like a motor hood lifting device (please refer Figure 8).

On Figure 8 it can be found an overview of common restraint actuators and their typical mounting location. The location naming adopted is valid for both left and right side steering wheel vehicles.

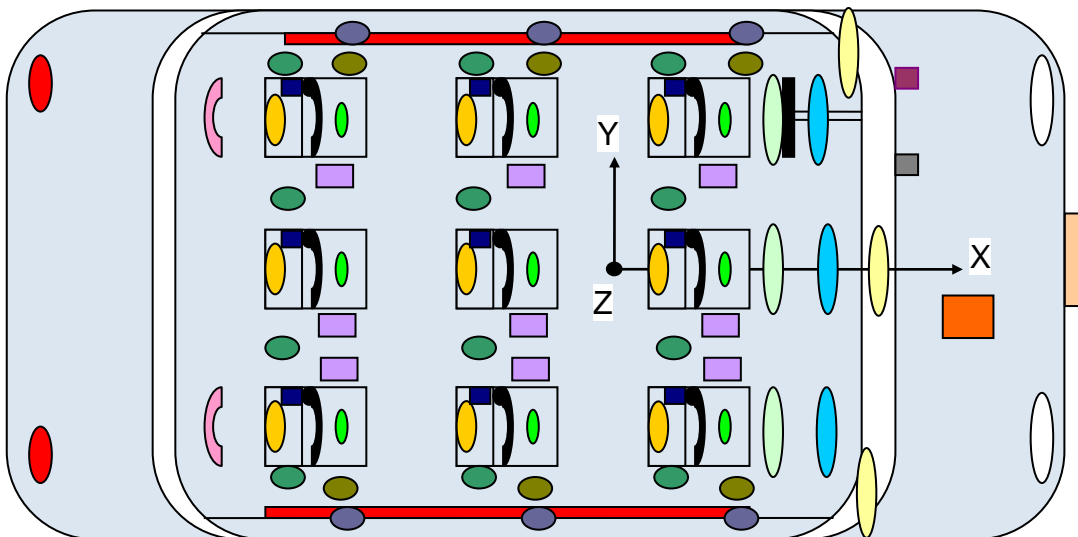
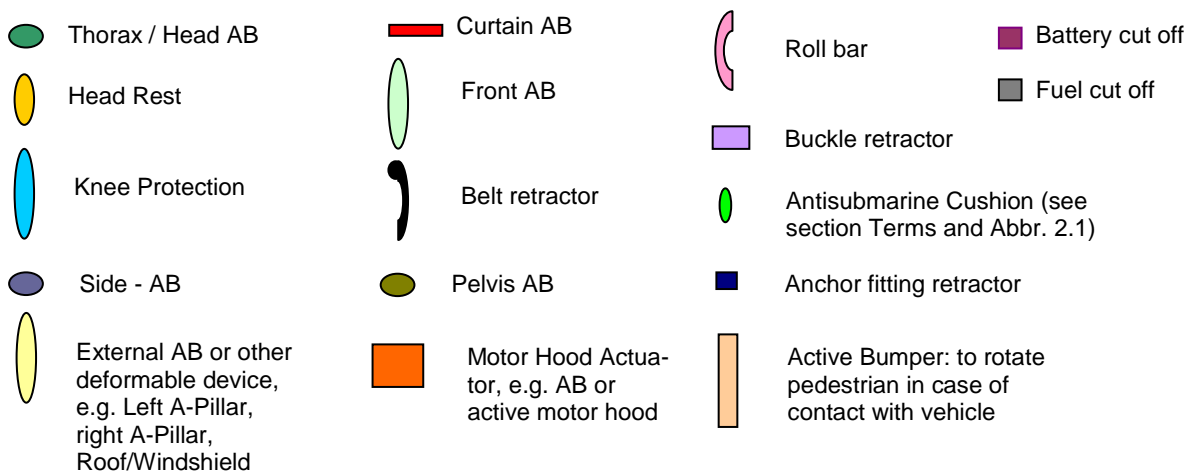

**Figure 8. Actuator Location in the vehicle for Occupant Protection In-Crash functions**

All actuators are optional, i.e. the actual actuator setup for a concrete Occupant and Pedestrian Protection Safety System is project-specific.

Depending on the actuator’s physical capabilities, the respective activation interface is quite simple (e.g. Boolean for activation (yes/no)). For more complex restraint devices, there might be additional control signals e.g. special adjustment control inter-

faces for belt load limitation at predefined force levels or airbag inflation control interfaces based on volume or stiffness target values. The control interfaces for complex Actuators provide for a finer deployment control of the Actuator, as opposed to a simple binary "deploy or not deploy" activation interface. These actuators can be deployed according to different degrees of activation, e.g. from "Low Activation" up to "Full Activation".

The actuators in Figure 8 can also be categorized into two main groups: Reversible and Non-Reversible actuators. Reversible actuators are those which can be activated an unlimited number of times, like for example reversible Belt Retractors; while Non-Reversible actuators can be deployed only once, like for example the Front Airbags. With the only exemption of the Airbag Actuators, all other Actuators can be either Reversible or Non-Reversible, depending on the specific project implementation.

The SWC's of the Actuator Pool Composition can also be categorized according to their restraint technology. In principle any Actuator SWC in the OPSS Domain belongs uniquely to one of the following actuator types:

- 1) Airbag: the actuator SWC's in this category are inflatable bags that are blew-up with high pressure gas in order to secure a quick inflation time thus the vehicle passengers are protected with a soft interface before getting in contact with hard elements of the vehicle structure, like e.g. a vehicle B-Pillar in the case of a severe side crash event. For a complete description please refer to 5.2
- 2) Roll bar: the actuator SWC's in this category are typically strong metal bars able to withstand the weight of the vehicle should it suffer a roll over accident and thus avoid contact of the upper body of vehicle passengers against the ground. For a complete description please refer to 5.2.
- 3) Head Rest: the actuator SWC's in this category are moveable seat head rest elements that are brought up to the correct height to keep the head of the seating passenger away from being strongly pulled backwards in the event of a crash, for example during a rear impact or during the head re-bounce phase in a frontal crash. For a complete description please refer to 5.2
- 4) Belt Tensioner: the actuator SWC's in this category are belt rolling devices that are able to quickly pull back the seat belt and thus bring the seating person to an optimal position to protect against the crash, for example, pull away from the instrument panel during a front crash, thus providing more free space for an airbag to inflate. For a complete description please refer to 5.2
- 5) Belt Limiter: the actuator SWC's in this category are force limiting devices that are aimed to soften the force applied by the seat belt when pulling back the passenger to a safe seating position. This is done with the goal of avoiding injuries exerted to the passenger upper body regions, in particular for small/thin persons, due to the high restraint force of typical Belt Tensioner actuators. For a complete description please refer to 5.2
- 6) Anchor Fitting Tensioner: the actuator SWC's in this category are belt retracting devices that are able to quickly pull back the seat belt on the anchor fitting point and thus keep the seating person in an optimal position to protect against the crash, for example, avoid that the person slides away from the seat surface due to the crash impact force. For a complete description please refer to 5.2



- 7) Buckle Retractor: the actuator SWC's in this category are belt retracting devices that are able to quickly pull back the seat belt on the belt buckle point and thus keep the seating person in an optimal position to protect against the crash, for example, avoid that the person slides away from the seat surface due to the crash impact force. For a complete description please refer to 5.2
- 8) Motor Hood: the actuator SWC's in this category are devices that lift the vehicle motor hood/bonnet in order to avoid direct contact from a colliding Pedestrian and the vehicle motor/engine block. For a complete description please refer to 5.2
- 9) Others: Fuel Pump Cut-Off, Battery Cut-Off. These are additional SWC's that implement special safety functions like cutting the Battery electrical connection to the vehicle or stopping the vehicle Fuel Pump, e.g. in the event of a crash, in order to prevent fuel to be pumped on the street due to an activated fuel pump. For a complete description please refer to 5.2

For a detailed description of the Actuators SWC's modelled in the AI Table (see [1]) please refer to 5.2. Please refer to the "Actuator Type" column in order to uniquely identify any Sensor SWC's listed in 5.1.

### 4.3 Crash Status (SWCo 003 CS)

Based on the OPS phases as described on 2.3 a crash event is modeled in a simplified way by means of sub-phases of crash activity. The CS SWCo is responsible for collecting the crash relevant information coming from the relevant sub systems of the vehicle and merging that information into an Autosar IF. The CS SWCo detailed here basically consists of a provider port with the following data:

CrashSt1 Value	State	Possible action (example)
1	Pre-Crash	None
2	Post-Crash	Automatic door unlocking Emergency call Warning light

Note: Previous version of Explanatory document was proposing a more refined definition. Figure 1, provides the correspondances between those two definitions.

This SWCo 003 CS will be part of a future release.

### 4.4 Seat Belt Reminder (SWCo 102 SBR)

The Seat Belt Reminder functionality is split into three components for the purpose of standardization. The logic behind the modularization is the representation of the functionality of warning when a passenger is not buckled, provided occupant detection is available for that seating position, as well as also informing whether the seat belt is buckled or not for the rest of the seating places (those without occupant detection). In addition, the SBR has a "Warn Control" component which takes care on conditioning the information for the Human Machine Interface elements for realization of the indication/warning functionality.

**Decomposition Seat Belt Reminder (SWCo 102 SBR)**

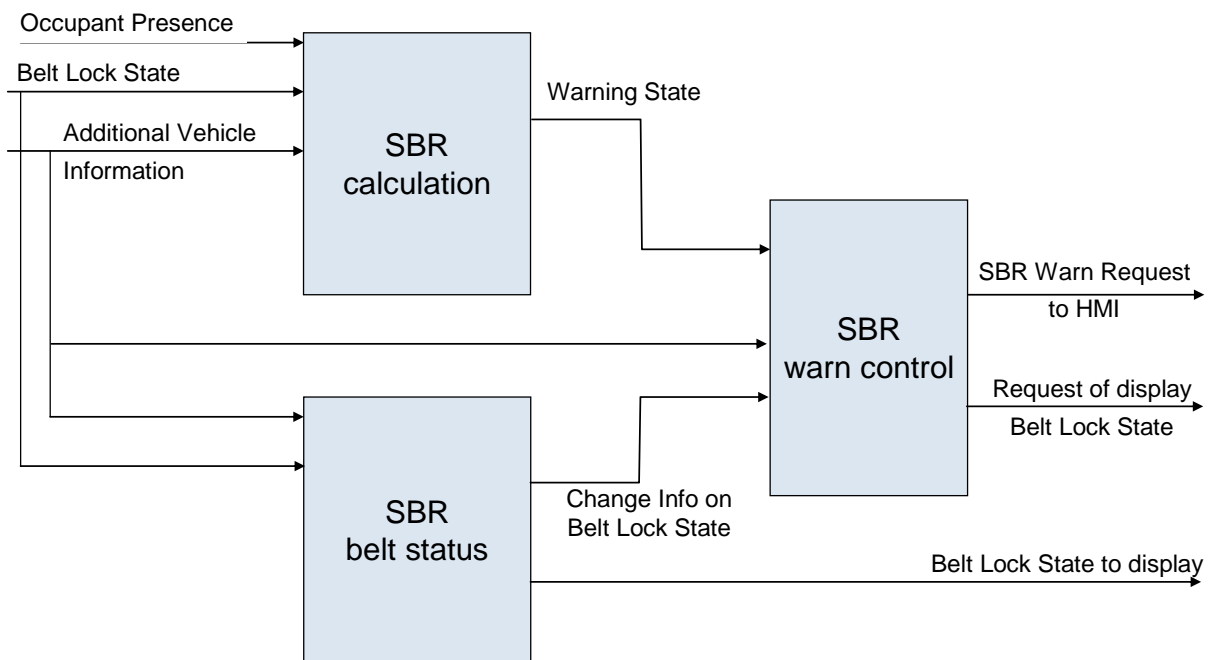

**Figure 9. Seat Belt Reminder Model**

As can be seen in Figure 9, the SBR calculation and SBR belt state SWC's share a number of common interface signals. The main difference between these two SWC's, from the interface point of view, is the usage of Occupant Presence State for the SBR calculation for seats with Occupant Sensing Systems or SBR Belt State Sensing for seats without an Occupant Sensing System.

#### **4.4.1 SWC Seat Belt Reminder Calculation**

This SWC is responsible for the evaluation of the status of the Belt Lock in accordance with the information of Occupant Presence, as well as other conditions related to the vehicle motion state, e.g. warn only when the vehicle is being driven and a passenger is not belted.

#### **4.4.2 SWC Seat Belt Reminder Belt State**

This SWC is responsible for detecting the Belt Lock state for seat places where no Occupant Presence information is available, as well as evaluating other conditions related to the vehicle motion state, e.g. display only when the vehicle is being driven and some seat positions have changed the buckle state.

#### **4.4.3 SWC Seat Belt Reminder Warn Control**

This SWC is responsible for conditioning the information of the SBR SWCo's for Calculation and Belt State for the further usage in Human Machine Interface SWCo's.

## 4.5 Vehicle Crash Detection (SWCo 301 VCD)

The VCD SWCo has the main goal of detecting vehicle collision events arising on the collision directions:

- Front, e.g. Front Left, Front Middle, Front Right
- Rear, e.g. Rear Left, Rear Middle, Rear Right; and
- Lateral (Side), e.g. Left Middle, Right Forward, etc.

The crash detection function implemented by VCD bases mainly on the information delivered by the sensors of the Sensor Pool SWCo (please refer to chapter section 4.1). In addition, VCD can receive and use further information delivered by other sources in the vehicle, typical case are Vehicle Dynamics signals made available by Chassis components like an Electronic Stability Control device, or Environmental Information like e.g. collision object angle delivered by a forward looking Driver Assistance System.

In order to detect a crash event, VCD provides at least one of the following interfaces:

- **Crash Severity:** this is an estimation of the intensity of a crash event, which depends on a number of factors, for example relative velocity between a vehicle and a crash partner, vehicle mass ratio between a vehicle and its crash partner, general crashworthiness behavior of the vehicle, among others. In general terms, the Crash Severity is a value that ranges from 0% for no crash over "Low" for crash events that imply low energy exchange between the crash partners up to "Very High" (100% highest detectable severity) for those events that lead to a high damage in the vehicle structure as well as to the occupants.
- **Crash Impact Location:** this is an estimation of the geometrical region in the vehicle perimeter where the crash event takes place, e.g. Crash Deformation due to a lateral crash impact on the Left Side Middle of the vehicle. Please refer to Figure 10 for an overview. As the Crash Location cannot be determined with exactitude in real time, the concept shown on the figure aims at estimating roughly the Impact Location based on bits identifying the perimeter area. Depending on the vehicle sensing architecture, supplementary information can be provided to the VCD SWCo for better estimation of the impact location. For example, if a crash event covers the full left part of the Front vehicle, both Bit0 and Bit1 would be set active while Bit2 is inactive. In case the impact location cannot be determined accurately, all bits are set (e.g. in a system where only one satellite sensor is equipped). For other examples please refer to Table 1 and Table 2.

Bit2, Bit1, Bit0	Interpretation
Binary 000	No crash impact
Binary 001	Back left side impact
Binary 010	Middle left side impact
Binary 011	Back and middle left side impact
Binary 100	Forward left side impact
Binary 101	Back and forward left side impact
Binary 110	Middle and forward left side impact
Binary 111	Back, middle and forward left side impact (i.e. full lateral impact)

**Table 1. Collision Side Left (would be symmetrical situation for the right side of the vehicle)**

Bit2, Bit1, Bit0	Interpretation
Binary 000	No crash impact
Binary 001	Front left impact
Binary 010	Front middle impact
Binary 011	Front left and middle impact
Binary 100	Front right impact
Binary 101	Front left and right impact
Binary 110	Front right and middle impact
Binary 111	Front left, middle and right impact (i.e. full frontal impact)

**Table 2. Collision Front (would be symmetrical situation for the rear of the vehicle)**

- Bits of Left impact location
- Bits of Rear impact location
- Bits of Right impact location
- Bits of Front impact location

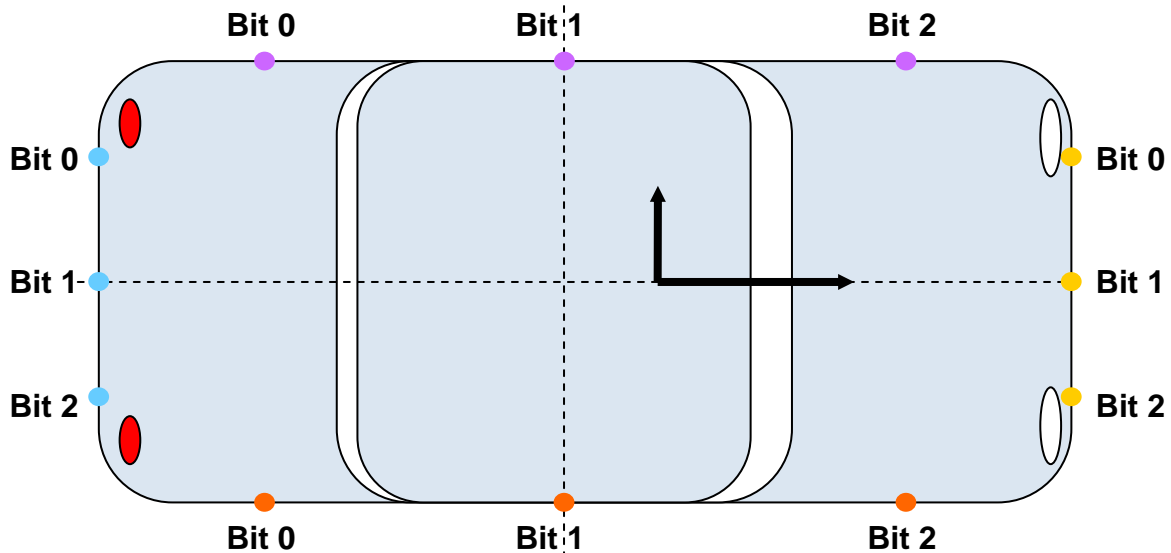

**Figure 10. Definition of Crash Impact Location around the vehicle perimeter.**

## 4.6 Roll- and Pitch- over Crash Detection (SWCo's 302 ROD, 303 POD)

The ROD and POD SWCo's are components that aim at the detection of strong rotatory events in which the vehicle turns itself around the X- (rollover) or Y- axis (pitch-over).

The main input for the ROD and POD functions is the information delivered by sensors measuring the vehicle rotatory velocity, as summarized on Chapter 4.1. By means of this type of sensors, the SWCo will determine if a critical inclination angle will be reached and/or surpassed, which will result in the vehicle turning around the measurement axis. To support such determination, ROD and POD utilize additional sensors like low- and mid-g lateral and longitudinal acceleration sensors mounted on the vehicle center of gravity.

ROD and POD SWCo's provide information relative to the rotation situation, e.g. whether the vehicle turns left/right for rollover, or forward(downward) / backward(upward) for pitchover. See 2.5.1 for more details.

## 4.7 Occupant Restraint System Activation (SWCo 304 ORA)

The ORA SWCo is responsible for the Deployment Strategy of the restraint systems in the vehicle, based in the first place on the information provided by the Crash Detection function VCD and the RollOver/PitchOver detection function (ROD/POD), and on the second place based on additional information, like Occupant Status information (e.g. buckled / not buckled) provided by an Occupant Detection SWCo (please refer to section 4.10). Furthermore, ORA can also process external incoming information coming like Vehicle Dynamics information or Environmental Information delivered by other components in the vehicle, like e.g. Chassis or Driver Assistance Components.

The Deployment Strategy is composed of the elements:

- Decision on which concrete Actuators from the Actuator Pool (SWCo 002 AP) are to be activated (deployed), please refer to 4.2.
- Activation timing for the selected actuators, i.e. decision of the point of time at which a determined actuator should be deployed, as well as definition of the sequence of activation over time. For example, ORA might decide that the deployment of the Belt Retractor on the driver side has to be followed by the deployment of a Knee Airbag in the Driver compartment, which in turn should be followed by the activation of the first stage of a Front Airbag; all this at different points in time.

## 4.8 Pedestrian Protection Crash Detection (SWCo 305 PCD)

The Pedestrian Crash Detection is done based on information delivered by state of the art sensors, which reside in the Sensor Pool SWCo (please refer to chapter section 4.1). The sensors are placed in several locations in the vehicle, as shown in Figure 7.

Following the same principle as the counterpart SWCo for Occupant Safety VCD, the PCD SWCo calculates at least one of the following interfaces:

- **Pedestrian Crash Severity:** this is an estimation of the intensity of a crash event, which depends on a number of factors, like velocity of the vehicle, vehicle mass, pedestrian crashworthiness behavior of the vehicle (e.g. stiff or soft Front End), among others.  
In general terms, the Crash Severity is a value that ranges from "Low" for crash events that imply low impact energy transferred by the vehicle to the Pedestrian, to "Very High" for those events that lead to a potential high injury of the Pedestrian.
- **Pedestrian Crash Impact Location:** this is an estimation of the geometrical region in the vehicle Front where the crash event takes place, e.g. from -100% to +100% covering the vehicle front. Depending on the vehicle sensing architecture, supplementary information can be provided to the PCD system for better estimation of the impact location.

The PCD SWCo can use additional information like a Front End temperature sensor, or the Vehicle Longitudinal Velocity provided by a Chassis Component.

## 4.9 Pedestrian Protection System Activation (SWCo 306 PPA)

The PPA SWCo has the task to implement the deployment strategy of the Pedestrian Protection Actuators based on the information provided by the PCD SWCo. Please refer to Figure 8 for an overview of the Pedestrian Actuator SWCo's.

Additional to the PCD information, the PPA SWCo can evaluate additional vehicle dynamic information, like longitudinal velocity.

## 4.10 Occupant Detection (SWCo 101 OD)

The OD SWCo has the main goal of detecting the presence of an Occupant on a seat place in the vehicle. Furthermore, OD does a classification of the Occupant into one of several Presence Status, e.g. "Seat empty", "Child Seat", etc. Please refer to [1] for a complete list of Presence Status classification elements.

The occupant detection function performed by OD bases mainly on the information delivered by Occupant Presence Sensors, which are not in the scope neither of this explanatory document nor of the main AI Table document. For the purpose of completeness, the OD SWCo was only partly modeled in the previously mentioned documents, in order to be able to provide a more complete view of the VCD and ORA SWCo's. Given this general limitation about the incompleteness of the modeling of the OD SWCo, its current purpose is to:

- Classify the Occupant of any seat in the vehicle into a class, e.g. "Child Seat Forward Face", "empty", "Adult 95% Person", etc;
- Determine the Occupant Weight on any seat in the vehicle;
- Determine the Occupant Out-of-Position seating position, e.g. Occupant in Critical Out of Position (i.e. Occupant seating very close to Airbag opening location on Front dashboard), Occupant Out of Position (Occupant seating close to Airbag opening location on Front dashboard, but not too close), Occupant In Position (Occupant seating at enough distance from Airbag opening location on Front dashboard). Please refer to [1] for a complete list of possible states.

Following are the Inputs to the OD SWCo (not limited to):

- Information delivered by Occupant Presence Sensors
- Seat Belt status and Seat Fixation status, e.g. from the Sensor Pool (please refer to 4.1)



## 5 Additional Information

### 5.1 Detailed Explanation of the Sensor Pool Port Names.

Following is a list of all Port Names of the Sensor Pool, please refer to Figure 7 and to [1]

SWC Name (Provider)	Sensor Port Name	Sensor Type	Sensing direction	Location	Detailed Location
SnsrAOnBmpAtFrntLe	AOnBmpAtFrntLe1	Acceleration	Longitudinal	Bumper	Front Left
SnsrAOnBmpAtFrntMidLe	AOnBmpAtFrntMidLe1	Acceleration	Longitudinal	Bumper	Front Mid Left
SnsrAOnBmpAtFrntMid	AOnBmpAtFrntMid1	Acceleration	Longitudinal	Bumper	Front Middle
SnsrAOnBmpAtFrntMidRi	AOnBmpAtFrntMidRi1	Acceleration	Longitudinal	Bumper	Front Mid Right
SnsrAOnBmpAtFrntRi	AOnBmpAtFrntRi1	Acceleration	Longitudinal	Bumper	Front Right
SnsrAAAtFrntLe	ALgtAtFrntLe1	Acceleration	Longitudinal	Front End	Front Left
SnsrAAAtFrntMid	ALgtAtFrntMid1	Acceleration	Longitudinal	Front End	Front Mid
SnsrAAAtFrntRi	ALgtAtFrntRi1	Acceleration	Longitudinal	Front End	Front Right
SnsrAOnDoorAtFrntLe	ALatOnDoorAtFrntLe1	Acceleration	Lateral	Front Door	Left
SnsrAOnDoorAtFrntRi	ALatOnDoorAtFrntRi1	Acceleration	Lateral	Front Door	Right
SnsrAOnDoorAtReLe	ALatOnDoorAtReLe1	Acceleration	Lateral	Rear Door	Left
SnsrAOnDoorAtReRi	ALatOnDoorAtReRi1	Acceleration	Lateral	Rear Door	Right
SnsrAAAtReLe	ALgtAtReLe1	Acceleration	Longitudinal	Rear End	Rear Left
SnsrAAAtReMid	ALgtAtReMid1	Acceleration	Longitudinal	Rear End	Rear Mid
SnsrAAAtReRi	ALgtAtReRi1	Acceleration	Longitudinal	Rear End	Rear Right
SnsrALgtAtCen	ALgtAtCen1	Acceleration	Longitudinal	Center (e.g. Tunnel)	
SnsrALatAtCen	ALatAtCen1	Acceleration	Lateral	Center (e.g. Tunnel)	
SnsrAUpwAtCen	AUpwAtCen1	Acceleration	Upwards	Center (e.g. Tunnel)	
SnsrPInDoorAtFrntLe	PInDoorAtFrntLe	Pressure	Door	Front	Left
SnsrPInDoorAtFrntRi	PInDoorAtFrntRi	Pressure	Door	Front	Right
SnsrPInDoorAtReLe	PInDoorAtReLe	Pressure	Door	Rear	Left
SnsrPInDoorAtReRi	PInDoorAtReRi	Pressure	Door	Rear	Right
BltLockAtDrvr	BltLockStAtDrvr	Buckle	Not relevant	Driver Seat	
BltLockAtRowFirstMid	BltLockStAtRowFirstMid	Buckle	Not relevant	First Seat Row	Mid
BltLockAtPass	BltLockStAtPass	Buckle	Not relevant	Passenger seat	
BltLockAtRowSecLe	BltLockStAtRowSecLe	Buckle	Not relevant	Second Seat Row	Left
BltLockAtRowSecMid	BltLockStAtRowSecMid	Buckle	Not relevant	Second Seat Row	Mid
BltLockAtRowSecRi	BltLockStAtRowSecRi	Buckle	Not relevant	Second Seat Row	Right
BltLockAtRowThrdLe	BltLockStAtRowThrdLe	Buckle	Not relevant	Third Seat Row	Left
BltLockAtRowThrdMid	BltLockStAtRowThrdMid	Buckle	Not relevant	Third Seat Row	Mid
BltLockAtRowThrdRi	BltLockStAtRowThrdRi	Buckle	Not relevant	Third Seat Row	Right
SnsrTAtBmp	TAtBmp	Temperature	Not relevant	Bumper	
SnsrAAAtFrntLe	ALatAtFrntLe1	Acceleration	Lateral	Front End	Left
SnsrAAAtFrntMid	ALatAtFrntMid1	Acceleration	Lateral	Front End	Mid
SnsrAAAtFrntRi	ALatAtFrntRi1	Acceleration	Lateral	Front End	Right
SnsrAOnDoorAtFrntLe	ALgtOnDoorAtFrntLe1	Acceleration	Longitudinal	Front Door	Left
SnsrAOnDoorAtFrntRi	ALgtOnDoorAtFrntRi1	Acceleration	Longitudinal	Front Door	Right
SnsrAOnDoorAtReLe	ALgtOnDoorAtReLe1	Acceleration	Longitudinal	Rear Door	Left
SnsrAOnDoorAtReRi	ALgtOnDoorAtReRi1	Acceleration	Longitudinal	Rear Door	Right
SnsrAAAtReLe	ALatAtReLe1	Acceleration	Lateral	Rear End	Left
SnsrAAAtReMid	ALatAtReMid1	Acceleration	Lateral	Rear End	Mid
SnsrAAAtReRi	ALatAtReRi1	Acceleration	Lateral	Rear End	Right
SnsrAAAtApilLe	ALatAtApilLe1	Acceleration	Lateral	A Pillar	Left
SnsrAAAtApilLe	ALgtAtApilLe1	Acceleration	Longitudinal	A Pillar	Left
SnsrAAAtApilRi	ALatAtApilRi1	Acceleration	Lateral	A Pillar	Right
SnsrAAAtApilRi	ALgtAtApilRi1	Acceleration	Longitudinal	A Pillar	Right
SnsrAAAtBpilLe	ALatAtBpilLe1	Acceleration	Lateral	B Pillar	Left
SnsrAAAtBpilLe	ALgtAtBpilLe1	Acceleration	Longitudinal	B Pillar	Left
SnsrAAAtBpilRi	ALatAtBpilRi1	Acceleration	Lateral	B Pillar	Right
SnsrAAAtBpilRi	ALgtAtBpilRi1	Acceleration	Longitudinal	B Pillar	Right
SnsrAAAtCpilLe	ALatAtCpilLe1	Acceleration	Lateral	C Pillar	Left
SnsrAAAtCpilLe	ALgtAtCpilLe1	Acceleration	Longitudinal	C Pillar	Left
SnsrAAAtCpilRi	ALatAtCpilRi1	Acceleration	Lateral	C Pillar	Right
SnsrAAAtCpilRi	ALgtAtCpilRi1	Acceleration	Longitudinal	C Pillar	Right
SnsrRngMidForALgtAtCen	ALgtAtCenWithRngMid	Acceleration	Longitudinal	Center (e.g. Tunnel)	
SnsrRngMidForALatAtCen	ALatAtCenWithRngMid	Acceleration	Lateral	Center (e.g. Tunnel)	
SnsrRngMidForAUpwAtCen	AUpwAtCenWithRngMid	Acceleration	Upwards	Center (e.g. Tunnel)	
SnsrRngLoForALgtAtCen	ALgtAtCenWithRngLo	Acceleration	Longitudinal	Center (e.g. Tunnel)	
SnsrRngLoForALatAtCen	ALatAtCenWithRngLo	Acceleration	Lateral	Center (e.g. Tunnel)	
SnsrRngLoForAUpwAtCen	AUpwAtCenWithRngLo	Acceleration	Upwards	Center (e.g. Tunnel)	
SnsrPitchRateAtCen	PitchRateAtCen	Acceleration	Rotational	Center (e.g. Tunnel)	
SnsrRollRateAtCen	RollRateAtCen	Acceleration	Rotational	Center (e.g. Tunnel)	
SnsrYawRateAtCen (Future Release)	YawRateAtCen	Acceleration	Rotational	Center (e.g. Tunnel)	

## 5.2 Detailed Explanation of the Actuator Pool Port Names.

Following is a list of all Port Names of the Actuator Pool, please refer to Figure 8 and to [1]

Actuator Port Name	Interface type	Actuator type	Location	Detailed Location	Purpose
ActvtOfActrAtHoodForPedProtn	Activation	e.g. Motor Hood	Front End		Pedestrian Protection
ActvtOfActrAtApilLeForPedProtn	Activation	e.g. Airbag	A Pillar		Pedestrian Protection
ActvtOfActrAtApilRiForPedProtn	Activation	e.g. Airbag	A Pillar		Pedestrian Protection
ActvtOfActrAtRoofForPedProtn	Activation	e.g. Airbag	Roof		Pedestrian Protection
ActvtOfActrAtBmpForPedProtn	Activation	e.g. Airbag	Bumper		Pedestrian Protection
CtrlOfActrAtHoodForPedProtn	Control	e.g. Motor Hood	Front End		Pedestrian Protection
CtrlOfActrAtApilLeForPedProtn	Control	e.g. Airbag	A Pillar		Pedestrian Protection
CtrlOfActrAtApilRiForPedProtn	Control	e.g. Airbag	A Pillar		Pedestrian Protection
CtrlOfActrAtRoofForPedProtn	Control	e.g. Airbag	Roof		Pedestrian Protection
CtrlOfActrAtBmpForPedProtn	Control	e.g. Airbag	Bumper		Pedestrian Protection
ActvtOfActrAirbFrntAtDrvr	Activation	Airbag	Driver Side		Crash Restraint
CtrlOfActrAirbFrntAtDrvr	Control	Airbag	Driver Side		Crash Restraint
ActvtOfActrAirbFrntAtRowFirstMid	Activation	Airbag	First Seat Row	Mid	Crash Restraint
CtrlOfActrAirbFrntAtRowFirstMid	Control	Airbag	First Seat Row	Mid	Crash Restraint
ActvtOfActrAirbFrntAtPass	Activation	Airbag	Passenger side		Crash Restraint
CtrlOfActrAirbFrntAtPass	Control	Airbag	Passenger side		Crash Restraint
ActvtOfActrKneeProtnAtDrvr	Activation	Airbag	Driver Side		Crash Restraint
CtrlOfActrKneeProtnAtDrvr	Control	Airbag	Driver Side		Crash Restraint
ActvtOfActrKneeProtnAtRowFirstMid	Activation	Airbag	First Seat Row	Mid	Crash Restraint
CtrlOfActrKneeProtnAtRowFirstMid	Control	Airbag	First Seat Row	Mid	Crash Restraint
ActvtOfActrKneeProtnAtPass	Activation	Airbag	Passenger side		Crash Restraint
CtrlOfActrKneeProtnAtPass	Control	Airbag	Passenger side		Crash Restraint
ActvtOfActrCurtAirbAtLe	Activation	Airbag	Left End	Left	Crash Restraint
CtrlOfActrCurtAirbAtLe	Control	Airbag	Left End	Left	Crash Restraint
ActvtOfActrCurtAirbAtRi	Activation	Airbag	Right End	Right	Crash Restraint
CtrlOfActrCurtAirbAtRi	Control	Airbag	Right End	Right	Crash Restraint
ActvtOfActrPelvProtnAtDrvr	Activation	e.g. Airbag	Driver Side		Crash Restraint
CtrlOfActrPelvProtnAtDrvr	Control	e.g. Airbag	Driver Side		Crash Restraint
ActvtOfActrPelvProtnAtPass	Activation	e.g. Airbag	Passenger side		Crash Restraint
CtrlOfActrPelvProtnAtPass	Control	e.g. Airbag	Passenger side		Crash Restraint
ActvtOfActrPelvProtnAtRowSecLe	Activation	e.g. Airbag	Second Seat Row	Left	Crash Restraint
CtrlOfActrPelvProtnAtRowSecLe	Control	e.g. Airbag	Second Seat Row	Left	Crash Restraint
ActvtOfActrPelvProtnAtRowSecRi	Activation	e.g. Airbag	Second Seat Row	Right	Crash Restraint
CtrlOfActrPelvProtnAtRowSecRi	Control	e.g. Airbag	Second Seat Row	Right	Crash Restraint
ActvtOfActrPelvProtnAtRowThrdLe	Activation	e.g. Airbag	Third Seat Row	Left	Crash Restraint
CtrlOfActrPelvProtnAtRowThrdLe	Control	e.g. Airbag	Third Seat Row	Left	Crash Restraint
ActvtOfActrPelvProtnAtRowThrdRi	Activation	e.g. Airbag	Third Seat Row	Right	Crash Restraint
CtrlOfActrPelvProtnAtRowThrdRi	Control	e.g. Airbag	Third Seat Row	Right	Crash Restraint
ActvtOfActrAirbSideAtDrvr	Activation	Airbag	Driver Side		Crash Restraint
CtrlOfActrAirbSideAtDrvr	Control	Airbag	Driver Side		Crash Restraint
ActvtOfActrAirbSideAtPass	Activation	Airbag	Passenger side		Crash Restraint
CtrlOfActrAirbSideAtPass	Control	Airbag	Passenger side		Crash Restraint
ActvtOfActrAirbSideAtRowSecLe	Activation	Airbag	Second Seat Row	Left	Crash Restraint
CtrlOfActrAirbSideAtRowSecLe	Control	Airbag	Second Seat Row	Left	Crash Restraint
ActvtOfActrAirbSideAtRowSecRi	Activation	Airbag	Second Seat Row	Right	Crash Restraint
CtrlOfActrAirbSideAtRowSecRi	Control	Airbag	Second Seat Row	Right	Crash Restraint
ActvtOfActrAirbSideAtRowThrdLe	Activation	Airbag	Third Seat Row	Left	Crash Restraint
CtrlOfActrAirbSideAtRowThrdLe	Control	Airbag	Third Seat Row	Left	Crash Restraint
ActvtOfActrAirbSideAtRowThrdRi	Activation	Airbag	Third Seat Row	Right	Crash Restraint
CtrlOfActrAirbSideAtRowThrdRi	Control	Airbag	Third Seat Row	Right	Crash Restraint

Actuator Port Name	Interface type	Actuator type	Location	Detailed Location	Purpose
ActvtOfActrRollbarAtLe	Activation	Rollbar	Left End	Left	Rollover Protection
ActvtOfActrRollbarAtRi	Activation	Rollbar	Right End	Right	Rollover Protection
ActvtOfActrHdrestAtDrvr	Activation	Head Rest	Driver Side		Crash Restraint
CtrlOfActrHdrestAtDrvr	Control	Head Rest	Driver Side		Crash Restraint
ActvtOfActrHdrestAtRowFirstMid	Activation	Head Rest	First Seat Row	Mid	Crash Restraint
CtrlOfActrHdrestAtRowFirstMid	Control	Head Rest	First Seat Row	Left	Crash Restraint
ActvtOfActrHdrestAtPass	Activation	Head Rest	Passenger side		Crash Restraint
CtrlOfActrHdrestAtPass	Control	Head Rest	Passenger side		Crash Restraint
ActvtOfActrHdrestAtRowSecLe	Activation	Head Rest	Second Seat Row	Left	Crash Restraint
CtrlOfActrHdrestAtRowSecLe	Control	Head Rest	Second Seat Row	Left	Crash Restraint
ActvtOfActrHdrestAtRowSecMid	Activation	Head Rest	Second Seat Row	Mid	Crash Restraint
CtrlOfActrHdrestAtRowSecMid	Control	Head Rest	Second Seat Row	Mid	Crash Restraint
ActvtOfActrHdrestAtRowSecRi	Activation	Head Rest	Second Seat Row	Right	Crash Restraint
CtrlOfActrHdrestAtRowSecRi	Control	Head Rest	Second Seat Row	Right	Crash Restraint
ActvtOfActrHdrestAtRowThrdLe	Activation	Head Rest	Third Seat Row	Left	Crash Restraint
CtrlOfActrHdrestAtRowThrdLe	Control	Head Rest	Third Seat Row	Left	Crash Restraint
ActvtOfActrHdrestAtRowThrdMid	Activation	Head Rest	Third Seat Row	Mid	Crash Restraint
CtrlOfActrHdrestAtRowThrdMid	Control	Head Rest	Third Seat Row	Mid	Crash Restraint
ActvtOfActrHdrestAtRowThrdRi	Activation	Head Rest	Third Seat Row	Right	Crash Restraint
CtrlOfActrHdrestAtRowThrdRi	Control	Head Rest	Third Seat Row	Right	Crash Restraint
ActvtOfActrFuCutOff	Activation	Not relevant	Not relevant		Crash Protection
ActvtOfActrBattCutOff	Activation	Not relevant	Not relevant		Crash Protection
ActvtOfActrBlitTensnrAtDrvr	Activation	Belt Tensioner	Driver Side		Crash Restraint
CtrlOfActrBlitTensnrAtDrvr	Control	Belt Tensioner	Driver Side		Crash Restraint
ActvtOfActrBlitTensnrAtRowFirstMid	Activation	Belt Tensioner	First Seat Row	Mid	Crash Restraint
CtrlOfActrBlitTensnrAtRowFirstMid	Control	Belt Tensioner	First Seat Row	Mid	Crash Restraint
ActvtOfActrBlitTensnrAtPass	Activation	Belt Tensioner	Passenger side		Crash Restraint
CtrlOfActrBlitTensnrAtPass	Control	Belt Tensioner	Passenger side		Crash Restraint
ActvtOfActrBlitTensnrAtRowSecLe	Activation	Belt Tensioner	Second Seat Row	Left	Crash Restraint
CtrlOfActrBlitTensnrAtRowSecLe	Control	Belt Tensioner	Second Seat Row	Left	Crash Restraint
ActvtOfActrBlitTensnrAtRowSecMid	Activation	Belt Tensioner	Second Seat Row	Mid	Crash Restraint
CtrlOfActrBlitTensnrAtRowSecMid	Control	Belt Tensioner	Second Seat Row	Mid	Crash Restraint
ActvtOfActrBlitTensnrAtRowSecRi	Activation	Belt Tensioner	Second Seat Row	Right	Crash Restraint
CtrlOfActrBlitTensnrAtRowSecRi	Control	Belt Tensioner	Second Seat Row	Right	Crash Restraint
ActvtOfActrBlitTensnrAtRowThrdLe	Activation	Belt Tensioner	Third Seat Row	Left	Crash Restraint
CtrlOfActrBlitTensnrAtRowThrdLe	Control	Belt Tensioner	Third Seat Row	Left	Crash Restraint
ActvtOfActrBlitTensnrAtRowThrdMid	Activation	Belt Tensioner	Third Seat Row	Mid	Crash Restraint
CtrlOfActrBlitTensnrAtRowThrdMid	Control	Belt Tensioner	Third Seat Row	Mid	Crash Restraint
ActvtOfActrBlitTensnrAtRowThrdRi	Activation	Belt Tensioner	Third Seat Row	Right	Crash Restraint
CtrlOfActrBlitTensnrAtRowThrdRi	Control	Belt Tensioner	Third Seat Row	Right	Crash Restraint
ActvtOfActrAnchrfitgTensnrAtDrvr	Activation	Anchor Fitting Tensioner	Driver Side		Crash Restraint
CtrlOfActrAnchrfitgTensnrAtDrvr	Control	Anchor Fitting Tensioner	Driver Side		Crash Restraint
ActvtOfActrAnchrfitgTensnrAtRowFirstMid	Activation	Anchor Fitting Tensioner	First Seat Row	Mid	Crash Restraint
CtrlOfActrAnchrfitgTensnrAtRowFirstMid	Control	Anchor Fitting Tensioner	First Seat Row	Mid	Crash Restraint
ActvtOfActrAnchrfitgTensnrAtPass	Activation	Anchor Fitting Tensioner	Passenger side		Crash Restraint
CtrlOfActrAnchrfitgTensnrAtPass	Control	Anchor Fitting Tensioner	Passenger side	Left	Crash Restraint
ActvtOfActrAnchrfitgTensnrAtRowSecLe	Activation	Anchor Fitting Tensioner	Second Seat Row	Left	Crash Restraint
CtrlOfActrAnchrfitgTensnrAtRowSecLe	Control	Anchor Fitting Tensioner	Second Seat Row	Mid	Crash Restraint
ActvtOfActrAnchrfitgTensnrAtRowSecMid	Activation	Anchor Fitting Tensioner	Second Seat Row	Mid	Crash Restraint
CtrlOfActrAnchrfitgTensnrAtRowSecMid	Control	Anchor Fitting Tensioner	Second Seat Row	Mid	Crash Restraint
ActvtOfActrAnchrfitgTensnrAtRowSecRi	Activation	Anchor Fitting Tensioner	Second Seat Row	Right	Crash Restraint
CtrlOfActrAnchrfitgTensnrAtRowSecRi	Control	Anchor Fitting Tensioner	Second Seat Row	Right	Crash Restraint
ActvtOfActrAnchrfitgTensnrAtRowThrdLe	Activation	Anchor Fitting Tensioner	Third Seat Row	Left	Crash Restraint
CtrlOfActrAnchrfitgTensnrAtRowThrdLe	Control	Anchor Fitting Tensioner	Third Seat Row	Left	Crash Restraint
ActvtOfActrAnchrfitgTensnrAtRowThrdMid	Activation	Anchor Fitting Tensioner	Third Seat Row	Mid	Crash Restraint
CtrlOfActrAnchrfitgTensnrAtRowThrdMid	Control	Anchor Fitting Tensioner	Third Seat Row	Mid	Crash Restraint
ActvtOfActrAnchrfitgTensnrAtRowThrdRi	Activation	Anchor Fitting Tensioner	Third Seat Row	Right	Crash Restraint
CtrlOfActrAnchrfitgTensnrAtRowThrdRi	Control	Anchor Fitting Tensioner	Third Seat Row	Right	Crash Restraint

Actuator Port Name	Interface type	Actuator type	Location	Detailed Location	Purpose
ActvtOfActrBltlLimrAtDrvr	Activation	Belt Limiter	Driver Side		Crash Restraint
CtrlOfActrBltlLimrAtDrvr	Control	Belt Limiter	Driver Side		Crash Restraint
ActvtOfActrBltlLimrAtRowFirstMid	Activation	Belt Limiter	First Seat Row	Mid	Crash Restraint
CtrlOfActrBltlLimrAtRowFirstMid	Control	Belt Limiter	First Seat Row	Mid	Crash Restraint
ActvtOfActrBltlLimrAtPass	Activation	Belt Limiter	Passenger side		Crash Restraint
CtrlOfActrBltlLimrAtPass	Control	Belt Limiter	Passenger side		Crash Restraint
ActvtOfActrBltlLimrAtRowSecLe	Activation	Belt Limiter	Second Seat Row	Left	Crash Restraint
CtrlOfActrBltlLimrAtRowSecLe	Control	Belt Limiter	Second Seat Row	Left	Crash Restraint
ActvtOfActrBltlLimrAtRowSecMid	Activation	Belt Limiter	Second Seat Row	Mid	Crash Restraint
CtrlOfActrBltlLimrAtRowSecMid	Control	Belt Limiter	Second Seat Row	Mid	Crash Restraint
ActvtOfActrBltlLimrAtRowSecRi	Activation	Belt Limiter	Second Seat Row	Right	Crash Restraint
CtrlOfActrBltlLimrAtRowSecRi	Control	Belt Limiter	Second Seat Row	Right	Crash Restraint
ActvtOfActrBltlLimrAtRowThrdLe	Activation	Belt Limiter	Third Seat Row	Left	Crash Restraint
CtrlOfActrBltlLimrAtRowThrdLe	Control	Belt Limiter	Third Seat Row	Left	Crash Restraint
ActvtOfActrBltlLimrAtRowThrdMid	Activation	Belt Limiter	Third Seat Row	Mid	Crash Restraint
CtrlOfActrBltlLimrAtRowThrdMid	Control	Belt Limiter	Third Seat Row	Mid	Crash Restraint
ActvtOfActrBltlLimrAtRowThrdRi	Activation	Belt Limiter	Third Seat Row	Right	Crash Restraint
CtrlOfActrBltlLimrAtRowThrdRi	Control	Belt Limiter	Third Seat Row	Right	Crash Restraint
ActvtOfActrBucRtrctrAtDrvr	Activation	Buckle Retractor	Driver Side		Crash Restraint
CtrlOfActrBucRtrctrAtDrvr	Control	Buckle Retractor	Driver Side		Crash Restraint
ActvtOfActrBucRtrctrAtRowFirstMid	Activation	Buckle Retractor	First Seat Row	Mid	Crash Restraint
CtrlOfActrBucRtrctrAtRowFirstMid	Control	Buckle Retractor	First Seat Row	Mid	Crash Restraint
ActvtOfActrBucRtrctrAtPass	Activation	Buckle Retractor	Passenger side		Crash Restraint
CtrlOfActrBucRtrctrAtPass	Control	Buckle Retractor	Passenger side		Crash Restraint
ActvtOfActrBucRtrctrAtRowSecLe	Activation	Buckle Retractor	Second Seat Row	Left	Crash Restraint
CtrlOfActrBucRtrctrAtRowSecLe	Control	Buckle Retractor	Second Seat Row	Left	Crash Restraint
ActvtOfActrBucRtrctrAtRowSecMid	Activation	Buckle Retractor	Second Seat Row	Mid	Crash Restraint
CtrlOfActrBucRtrctrAtRowSecMid	Control	Buckle Retractor	Second Seat Row	Mid	Crash Restraint
ActvtOfActrBucRtrctrAtRowSecRi	Activation	Buckle Retractor	Second Seat Row	Right	Crash Restraint
CtrlOfActrBucRtrctrAtRowSecRi	Control	Buckle Retractor	Second Seat Row	Right	Crash Restraint
ActvtOfActrBucRtrctrAtRowThrdLe	Activation	Buckle Retractor	Third Seat Row	Left	Crash Restraint
CtrlOfActrBucRtrctrAtRowThrdLe	Control	Buckle Retractor	Third Seat Row	Left	Crash Restraint
ActvtOfActrBucRtrctrAtRowThrdMid	Activation	Buckle Retractor	Third Seat Row	Mid	Crash Restraint
CtrlOfActrBucRtrctrAtRowThrdMid	Control	Buckle Retractor	Third Seat Row	Mid	Crash Restraint
ActvtOfActrBucRtrctrAtRowThrdRi	Activation	Buckle Retractor	Third Seat Row	Right	Crash Restraint
CtrlOfActrBucRtrctrAtRowThrdRi	Control	Buckle Retractor	Third Seat Row	Right	Crash Restraint