

<b>Document Title</b>	Specification of UDP Network Management
<b>Document Owner</b>	AUTOSAR
<b>Document Responsibility</b>	AUTOSAR
<b>Document Identification No</b>	414
<b>Document Classification</b>	Standard
<b>Document Status</b>	Final
<b>Part of AUTOSAR Release</b>	4.2.2

<b>Document Change History</b>		
<b>Release</b>	<b>Changed by</b>	<b>Change Description</b>
4.2.2	AUTOSAR Release Management	<ul style="list-style-type: none"> <li>Revised Error Classification</li> <li>Added support for Car Wakeup</li> <li>Bug fixes and editorial changes</li> </ul>
4.2.1	AUTOSAR Release Management	<ul style="list-style-type: none"> <li>Harmonization of API description</li> <li>Revised Partial Networking Requirements</li> <li>Extended Production Errors</li> <li>Editorial Changes</li> </ul>
4.1.3	AUTOSAR Release Management	<ul style="list-style-type: none"> <li>Minor bug fixes</li> <li>Editorial Changes</li> </ul>
4.1.2	AUTOSAR Release Management	<ul style="list-style-type: none"> <li>Revised Spontaneous Transmission</li> <li>Editorial changes</li> <li>Removed chapter(s) on change documentation</li> </ul>
4.1.1	AUTOSAR Administration	<ul style="list-style-type: none"> <li>Added support for Partial Networking</li> <li>Added updated production errors</li> <li>Editorial changes</li> </ul>
4.0.3	AUTOSAR Administration	<ul style="list-style-type: none"> <li>Support coordinated shutdown</li> <li>New traceability mechanism</li> </ul>
3.1.5	AUTOSAR Administration	<ul style="list-style-type: none"> <li>ComStack Harmonization</li> <li>Harmonization of NM interfaces</li> </ul>
3.1.4	AUTOSAR Administration	<ul style="list-style-type: none"> <li>Initial Release</li> </ul>

## Disclaimer

This specification and the material contained in it, as released by AUTOSAR, is for the purpose of information only. AUTOSAR and the companies that have contributed to it shall not be liable for any use of the specification.

The material contained in this specification is protected by copyright and other types of Intellectual Property Rights. The commercial exploitation of the material contained in this specification requires a license to such Intellectual Property Rights.

This specification may be utilized or reproduced without any modification, in any form or by any means, for informational purposes only. For any other purpose, no part of the specification may be utilized or reproduced, in any form or by any means, without permission in writing from the publisher.

The AUTOSAR specifications have been developed for automotive applications only. They have neither been developed, nor tested for non-automotive applications.

The word AUTOSAR and the AUTOSAR logo are registered trademarks.

## Advice for users

AUTOSAR specifications may contain exemplary items (exemplary reference models, "use cases", and/or references to exemplary technical solutions, devices, processes or software).

Any such exemplary items are contained in the specifications for illustration purposes only, and they themselves are not part of the AUTOSAR Standard. Neither their presence in such specifications, nor any later documentation of AUTOSAR conformance of products actually implementing such exemplary items, imply that intellectual property rights covering such exemplary items are licensed under the same rules as applicable to the AUTOSAR Standard.

## Table of Contents

1	Introduction and Functional Overview .....	6
2	Acronyms and abbreviations .....	7
3	Related documentation.....	8
3.1	Input documents.....	8
3.2	Related standards and norms .....	9
3.3	Related specification .....	9
4	Constraints and assumptions .....	10
4.1	Limitations .....	10
4.2	Applicability to car domains.....	10
5	Dependencies on other modules.....	11
5.1	File Structure .....	11
5.1.1	Code File Structure .....	11
5.1.2	Header File Structure.....	11
6	Requirements traceability .....	13
7	Functional specification .....	22
7.1	Coordination algorithm .....	22
7.2	Operational Modes .....	22
7.2.1	Network Mode.....	23
7.2.2	Prepare Bus-Sleep Mode.....	26
7.2.3	Bus-Sleep Mode .....	26
7.3	Network states.....	28
7.4	Initialization.....	28
7.5	Execution.....	29
7.5.1	Processor architecture .....	29
7.5.2	Timing parameters.....	29
7.6	Communication Scheduling.....	30
7.6.1	NM Message Transmission.....	30
7.6.2	Reception.....	31
7.7	Additional features.....	31
7.7.1	Detection of Remote Sleep Indication (optional) .....	31
7.7.2	User Data (optional).....	32
7.7.3	Passive Mode (optional) .....	32
7.7.4	NM PDU Rx Indication (optional) .....	32
7.7.5	State change notification (optional).....	33
7.7.6	Communication Control (optional).....	33
7.7.7	NM Coordinator synchronization support (optional) .....	34
7.8	Partial Networking .....	35
7.8.1	Rx Handling of NM PDUs .....	35
7.8.2	Tx Handling of NM PDUs.....	35
7.8.3	NM PDU Filter Algorithm.....	35
7.8.4	Aggregation of Internal and External Requested Partial Networks .....	36
7.8.5	Aggregation of External Requested Partial Networks .....	38
7.8.6	Spontaneous Transmission of NM-PDUs via UdpNm_NetworkRequest39	

7.9	Payload (PDU) Structure .....	40
7.10	Functional requirements on UdpNm API .....	41
7.11	Car Wakeup .....	42
7.12	Error Classification .....	42
7.12.1	Development Errors .....	43
7.12.2	Run Time Errors .....	43
7.12.3	Transient Faults .....	43
7.12.4	Production Errors.....	43
7.12.5	Extended Production Errors.....	43
7.12.6	Error detection .....	43
7.12.7	Error notification .....	44
7.13	Scheduling of the main function .....	44
7.14	Application notes .....	45
7.14.1	Wakeup notification .....	45
7.14.2	Coordination of coupled networks .....	45
7.14.3	Debugging Concept.....	45
7.15	Version check.....	45
8	API specification.....	46
8.1	Imported Types .....	46
8.2	Type Definitions.....	46
8.2.1	UdpNm_ConfigType .....	46
8.2.2	UdpNm_PduPositionType.....	47
8.3	UdpNm Functions called by the Nm .....	47
8.3.1	UdpNm_Init.....	47
8.3.2	UdpNm_PassiveStartUp .....	47
8.3.3	UdpNm_NetworkRequest .....	48
8.3.4	UdpNm_NetworkRelease .....	49
8.3.5	UdpNm_DisableCommunication .....	49
8.3.6	UdpNm_EnableCommunication.....	50
8.3.7	UdpNm_SetUserData .....	51
8.3.8	UdpNm_GetUserData.....	52
8.3.9	UdpNm_GetNodeIdentifier.....	52
8.3.10	UdpNm_GetLocalNodeIdentifier.....	53
8.3.11	UdpNm_RepeatMessageRequest .....	54
8.3.12	UdpNm_GetPduData.....	55
8.3.13	UdpNm_GetState .....	56
8.3.14	UdpNm_GetVersionInfo.....	56
8.3.15	UdpNm_RequestBusSynchronization.....	57
8.3.16	UdpNm_CheckRemoteSleepIndication .....	57
8.3.17	UdpNm_SetCoordBits .....	58
8.3.18	UdpNm_SetSleepReadyBit .....	59
8.4	UdpNm functions called by the SoAd .....	59
8.4.1	UdpNm_SoAdIfTxConfirmation.....	59
8.4.2	UdpNm_SoAdIfRxIndication .....	60
8.5	UdpNm functions called by the PDU-Router .....	61
8.5.1	UdpNm_Transmit.....	61
8.6	Scheduled Functions .....	62
8.6.1	UdpNm_MainFunction_<Instance Id>.....	62
8.7	Expected Interfaces.....	63

8.7.1	Mandatory Interfaces .....	63
8.7.2	Optional Interfaces .....	64
8.7.3	Configurable interfaces .....	64
8.7.4	Job End Notification .....	65
8.8	Parameter check .....	65
8.9	UML State chart diagram.....	66
9	Sequence diagrams and Transition Tables .....	67
9.1	UdpNmTransmission .....	67
9.2	UdpNm Reception .....	67
10	Configuration specification .....	69
10.1	How to read this chapter .....	69
10.2	Containers and configuration parameters .....	69
10.2.1	Variants .....	70
10.2.2	UdpNm .....	70
10.2.3	UdpNmGlobalConfig.....	71
10.2.4	UdpNmChannelConfig.....	80
10.2.5	UdpNmRxPdu.....	89
10.2.6	UdpNmTxPdu .....	90
10.2.7	UdpNmUserDataTxPdu .....	91
10.2.8	UdpNmDemEventParameterRefs.....	92
10.2.9	UdpNmPnInfo .....	93
10.2.10	UdpNmPnFilterMaskByte .....	96
10.3	Published parameters .....	96
11	Not applicable requirements .....	97

# 1 Introduction and Functional Overview

This document describes the concept, core functionality, optional features, interfaces and configuration issues of the AUTOSAR UDP Network Management (UdpNm). UdpNm is intended to be an optional feature. It is intended to work together with a TCP/IP Stack, independent of the physical layer of the communication system used. The AUTOSAR UDP Network Management is a hardware independent protocol that can be used on TCP/IP based systems (for limitations refer to chapter 4.1). Its main purpose is to coordinate the transition between normal operation and bus-sleep mode of the network.

In addition to the core functionality optional features are provided e.g. to implement a service to detect all present nodes or to detect if all other nodes are ready to sleep. The UDP Network Management (UdpNm) function provides an adaptation between Network Management Interface (Nm) and a TCP/IP Stack (TCP/IP). For a general understanding of the AUTOSAR Network Management functionality please refer to [9].

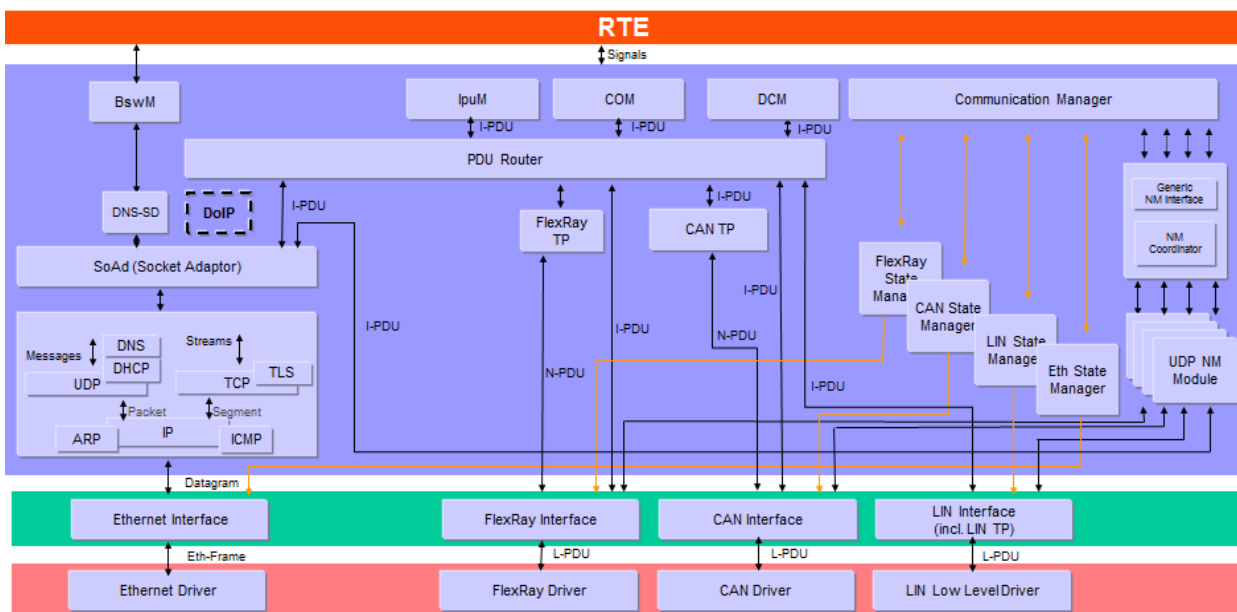

**Figure 1: Extended AUTOSAR Communication Stack.**

## 2 Acronyms and abbreviations

<b>Acronym or Abbreviation:</b>	<b>Description:</b>
<b>API</b>	Application Programming Interface
<b>BSW</b>	Basic Software
<b>EthIf</b>	Ethernet Interface
<b>DEM</b>	Diagnostic Event Manager
<b>DET</b>	Default Error Tracer
<b>IP</b>	Internet Protocol
<b>NM</b>	Network Management
<b>PDU</b>	Protocol Data Unit
<b>SDU</b>	Service Data Unit
<b>TCP</b>	Transmission Control Protocol
<b>TCP/IP</b>	A family of communication protocols used in computer networks
<b>UDP</b>	User Datagram Protocol
<b>PNI</b>	Partial Network Information
<b>UdpNm</b>	UDP Network Management

<b>Term:</b>	<b>Description:</b>
<b>PDU transmission ability is disabled</b>	This means that the NM message transmission has been disabled by the optional service UdpNm_DisableCommunication.
<b>Repeat Message Request Bit Indication</b>	UdpNm_SoAdIfRxIndication finds the Repeat Message Bit set in the Control Bit Vector of a received NM message.
<b>NM PDU</b>	Refers to the payload transmitted in a packet. It contains the NM User Data as well as the Control Bit Vector and the Source Node Identifier.
<b>NM Packet</b>	Refers to an Ethernet Frame containing an IP as well as a UDP header in addition to the data (PDU) transmitted by the NM in the payload section.
<b>NM Message</b>	Most abstract term referring to any single information item transferred within the methodology of the NM algorithm.
<b>Bus-Off state</b>	Refers to a situation where no cable is connected to the Ethernet HW.

### 3 Related documentation

#### 3.1 Input documents

- [1] Layered Software Architecture  
AUTOSAR\_EXP\_LayeredSoftwareArchitecture.pdf
- [2] General Requirements on Basic Software Modules  
AUTOSAR\_SRS\_BSWGeneral.pdf
- [3] Requirements on Network Management  
AUTOSAR\_SRS\_NetworkManagement.pdf
- [4] Specification of Ethernet Interface  
AUTOSAR\_SWS\_EthernetInterface.pdf
- [5] Specification of FlexRay Network Management  
AUTOSAR\_SWS\_FlexRayNetworkManagement.pdf
- [6] Specification of Communication Stack Types  
AUTOSAR\_SWS\_CommunicationStackTypes.pdf
- [7] Specification of ECU Configuration  
AUTOSAR\_TPS\_ECUConfiguration.pdf
- [8] Specification of BSW Scheduler  
AUTOSAR\_SWS\_BSW\_Scheduler.pdf
- [9] Specification of Generic Network Management Interface  
AUTOSAR\_SWS\_NetworkManagementInterface.pdf
- [10] Specification of Communication Manager  
AUTOSAR\_SWS\_ComManager.pdf
- [11] Specification of ECU State Manager  
AUTOSAR\_SWS\_ECUCStateManager.pdf
- [12] Specification of Operating System  
AUTOSAR\_SWS\_OS.pdf
- [13] Specification of Diagnostic Event Manager  
AUTOSAR\_SWS\_DiagnosticEventManager.pdf
- [14] Specification of Default Error Tracer  
AUTOSAR\_SWS\_Default ErrorTracer.pdf
- [15] Specification of Standard Types  
AUTOSAR\_SWS\_StandardTypes.pdf



- [16] Specification of Platform Types  
AUTOSAR\_SWS\_PlatformTypes.pdf
- [17] Specification of Compiler Abstraction  
AUTOSAR\_SWS\_CompilerAbstraction.pdf
- [18] Basic Software Module Description Template  
AUTOSAR\_TPS\_BSWModuleDescriptionTemplate.pdf
- [19] Specification of Socket Adaptor  
AUTOSAR\_SWS\_SocketAdaptor.pdf
- [20] Requirements on Ethernet  
AUTOSAR\_SRS\_Ethernet.pdf
- [21] List of Basic Software Modules  
AUTOSAR\_TR\_BSWModuleList
- [22] General Specification of Basic Software Modules  
AUTOSAR\_SWS\_BSWGeneral.pdf

### 3.2 Related standards and norms

- [23] IEEE  
<http://www.opengroup.org/onlinepubs/000095399/>
- [24] ISO 14229 Road Vehicles – Unified Diagnostic Services (UDS)

### 3.3 Related specification

AUTOSAR provides a General Specification on Basic Software modules [22] (SWS BSW General), which is also valid for UDP Network Management.

Thus, the specification SWS BSW General shall be considered as additional and required specification for UDP Network Management.

## 4 Constraints and assumptions

### 4.1 Limitations

1. One instance of UdpNm is associated with only one NM-Cluster in one network. One NM-Cluster can have only one instance of UdpNm in one node.
2. One instance of UdpNm is associated with only one network within the same ECU.
3. UdpNm is only applicable for TCP/IP based systems.

Figure 2 presents an AUTOSAR NM stack within an example ECU belonging to two UDP NM-clusters.

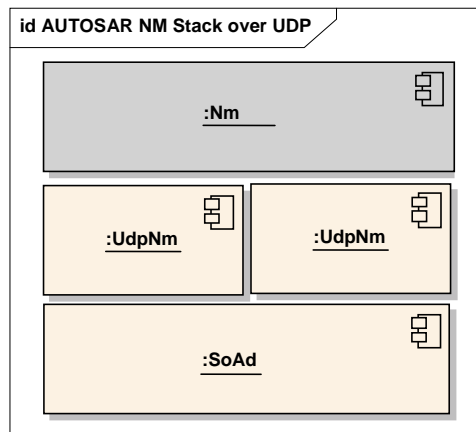

**Figure 2: AUTOSAR NM stack within an example ECU belonging to two UDP NM-clusters**

[SWS\_UdpNm\_00131] The AUTOSAR UdpNm algorithm shall support up to 250 nodes per NM-Cluster by default.

Note: The AUTOSAR UdpNm algorithm can support an arbitrary number of nodes per NM-cluster (even more than default 250 nodes per cluster, if necessary) – it is only a matter of configuration, since the upper limit is not fixed and depends on the trade off between response time, fault-tolerance and resulted bus load configured for the AUTOSAR UdpNm coordination algorithm. This might depend on the physical layer used. ] ( )

### 4.2 Applicability to car domains

N/A

## 5 Dependencies on other modules

UDP Network Management (UdpNm) uses services of the TCP/IP Stack and provides services to the Generic Network Management Interface (Nm).

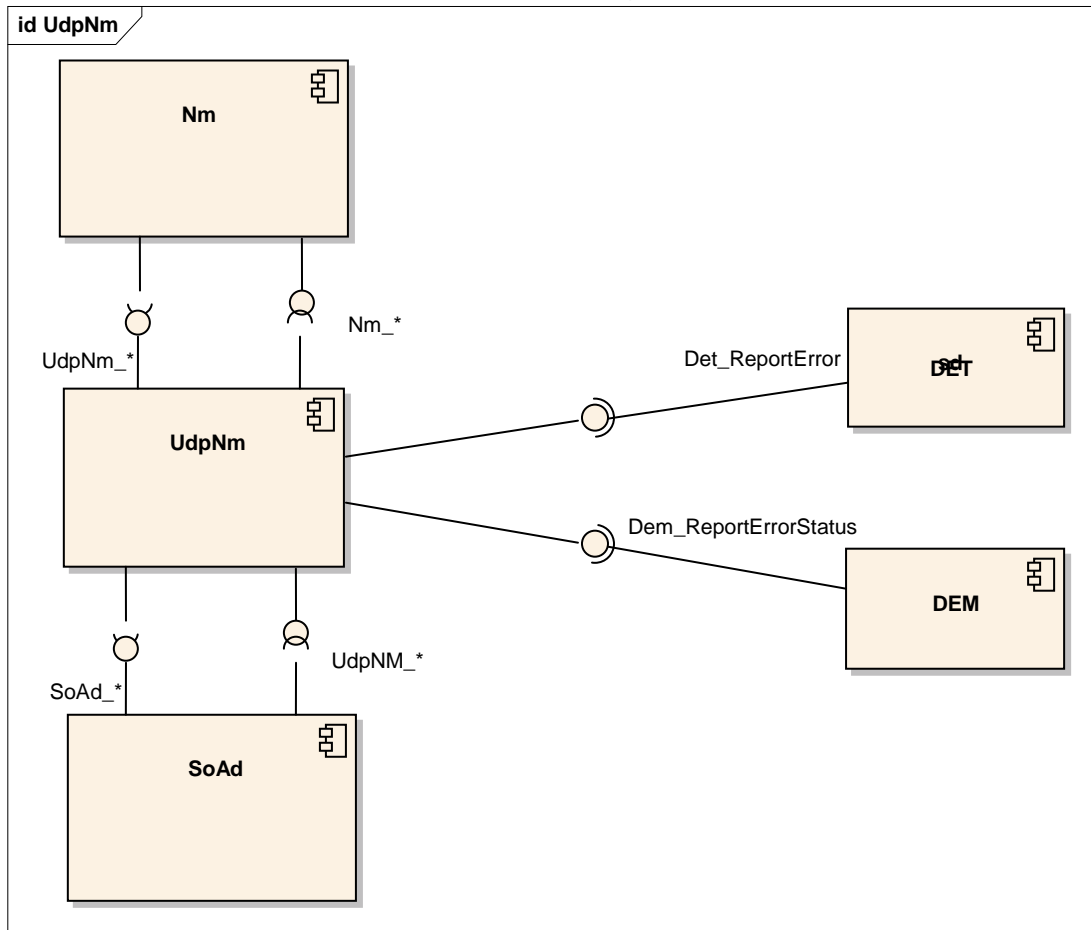

Figure 3: Dependencies on other modules.

### 5.1 File Structure

#### 5.1.1 Code File Structure

[SWS\_UdpNm\_00081] The code file structure shall not be fully defined within this specification. However, the code file structure shall include the following files:

UdpNm\_Lcfg.c (for link time configurable parameters)

UdpNm\_PBcfg.c (for post build time configurable parameters)

These files shall contain all link time post build time configurable parameters.  
] (SRS\_BSW\_00419, SRS\_BSW\_00346, SRS\_BSW\_00158, SRS\_BSW\_00308)

#### 5.1.2 Header File Structure

[SWS\_UdpNm\_00044] The UdpNm module shall provide the following H-files:

UdpNm.h (for declaration of provided interface functions)

UdpNm\_Cbk.h (for declaration of provided call-back functions)

UdpNm\_Cfg.h (for pre-compile time configurable parameters)

] (SRS\_BSW\_00345, SRS\_BSW\_00381, SRS\_BSW\_00412,  
SRS\_BSW\_00346, SRS\_BSW\_00158, SRS\_BSW\_00370,  
SRS\_BSW\_00302)

[SWS\_UdpNm\_00082] [ The UdpNm module shall include the following H-files:

ComStack\_Types.h

**Note:** The following header files are indirectly included by  
ComStack\_Types.h:

- o Std\_Types.h (for AUTOSAR standard types )
- o Platform\_Types.h (for platform specific types)
- o Compiler.h (for compiler specific language extensions)

UdpNm.h (for declaration of provided interface functions)

Nm\_Cbk.h (for UdpNm specific call-backs to the Generic Network  
Management Interface)

Det.h (for interface of DET – optional included only if DET is configured)

NmStack\_Types.h (for common network management types)

SchM\_UdpNm.h (for services of the Basic Software Scheduler)

UdpNm\_MemMap.h (for Memory Mapping) ] (SRS\_BSW\_00348,  
SRS\_BSW\_00353, SRS\_BSW\_00361, SRS\_BSW\_00301)

[SWS\_UdpNm\_00083] [ The UdpNM module shall include the following header  
files containing configuration data:

SoAd\_Cfg.h (for the PDU IDs and socket connections)

Nm\_Cfg.h (for the derived configuration items from Nm)  
] (SRS\_BSW\_00383, SRS\_BSW\_00301)

[SWS\_UdpNm\_00311] [ The UdpNm module shall include PduR\_UdpNm.h if  
UdpNmComUserDataSupport is enabled. ] ()

## 6 Requirements traceability

Requirement	Description	Satisfied by
-	-	SWS_UdpNm_00005
-	-	SWS_UdpNm_00013
-	-	SWS_UdpNm_00014
-	-	SWS_UdpNm_00018
-	-	SWS_UdpNm_00025
-	-	SWS_UdpNm_00026
-	-	SWS_UdpNm_00032
-	-	SWS_UdpNm_00033
-	-	SWS_UdpNm_00035
-	-	SWS_UdpNm_00037
-	-	SWS_UdpNm_00039
-	-	SWS_UdpNm_00040
-	-	SWS_UdpNm_00045
-	-	SWS_UdpNm_00051
-	-	SWS_UdpNm_00060
-	-	SWS_UdpNm_00061
-	-	SWS_UdpNm_00072
-	-	SWS_UdpNm_00074
-	-	SWS_UdpNm_00075
-	-	SWS_UdpNm_00076
-	-	SWS_UdpNm_00085
-	-	SWS_UdpNm_00086
-	-	SWS_UdpNm_00087
-	-	SWS_UdpNm_00088
-	-	SWS_UdpNm_00089
-	-	SWS_UdpNm_00092
-	-	SWS_UdpNm_00093
-	-	SWS_UdpNm_00094
-	-	SWS_UdpNm_00095
-	-	SWS_UdpNm_00096
-	-	SWS_UdpNm_00097
-	-	SWS_UdpNm_00098
-	-	SWS_UdpNm_00099
-	-	SWS_UdpNm_00100
-	-	SWS_UdpNm_00101
-	-	SWS_UdpNm_00102

-	-	SWS_UdpNm_00103
-	-	SWS_UdpNm_00104
-	-	SWS_UdpNm_00105
-	-	SWS_UdpNm_00106
-	-	SWS_UdpNm_00107
-	-	SWS_UdpNm_00108
-	-	SWS_UdpNm_00109
-	-	SWS_UdpNm_00110
-	-	SWS_UdpNm_00111
-	-	SWS_UdpNm_00112
-	-	SWS_UdpNm_00113
-	-	SWS_UdpNm_00114
-	-	SWS_UdpNm_00115
-	-	SWS_UdpNm_00116
-	-	SWS_UdpNm_00117
-	-	SWS_UdpNm_00118
-	-	SWS_UdpNm_00119
-	-	SWS_UdpNm_00120
-	-	SWS_UdpNm_00121
-	-	SWS_UdpNm_00122
-	-	SWS_UdpNm_00123
-	-	SWS_UdpNm_00124
-	-	SWS_UdpNm_00126
-	-	SWS_UdpNm_00127
-	-	SWS_UdpNm_00128
-	-	SWS_UdpNm_00129
-	-	SWS_UdpNm_00130
-	-	SWS_UdpNm_00131
-	-	SWS_UdpNm_00132
-	-	SWS_UdpNm_00133
-	-	SWS_UdpNm_00135
-	-	SWS_UdpNm_00137
-	-	SWS_UdpNm_00138
-	-	SWS_UdpNm_00139
-	-	SWS_UdpNm_00141
-	-	SWS_UdpNm_00143
-	-	SWS_UdpNm_00144
-	-	SWS_UdpNm_00145
-	-	SWS_UdpNm_00146

-	-	SWS_UdpNm_00147
-	-	SWS_UdpNm_00148
-	-	SWS_UdpNm_00149
-	-	SWS_UdpNm_00150
-	-	SWS_UdpNm_00151
-	-	SWS_UdpNm_00152
-	-	SWS_UdpNm_00153
-	-	SWS_UdpNm_00154
-	-	SWS_UdpNm_00158
-	-	SWS_UdpNm_00159
-	-	SWS_UdpNm_00160
-	-	SWS_UdpNm_00161
-	-	SWS_UdpNm_00162
-	-	SWS_UdpNm_00163
-	-	SWS_UdpNm_00164
-	-	SWS_UdpNm_00165
-	-	SWS_UdpNm_00166
-	-	SWS_UdpNm_00168
-	-	SWS_UdpNm_00169
-	-	SWS_UdpNm_00170
-	-	SWS_UdpNm_00172
-	-	SWS_UdpNm_00173
-	-	SWS_UdpNm_00174
-	-	SWS_UdpNm_00175
-	-	SWS_UdpNm_00176
-	-	SWS_UdpNm_00177
-	-	SWS_UdpNm_00178
-	-	SWS_UdpNm_00179
-	-	SWS_UdpNm_00180
-	-	SWS_UdpNm_00181
-	-	SWS_UdpNm_00185
-	-	SWS_UdpNm_00187
-	-	SWS_UdpNm_00189
-	-	SWS_UdpNm_00190
-	-	SWS_UdpNm_00191
-	-	SWS_UdpNm_00192
-	-	SWS_UdpNm_00193
-	-	SWS_UdpNm_00194
-	-	SWS_UdpNm_00196

-	-	SWS_UdpNm_00197
-	-	SWS_UdpNm_00198
-	-	SWS_UdpNm_00199
-	-	SWS_UdpNm_00201
-	-	SWS_UdpNm_00202
-	-	SWS_UdpNm_00203
-	-	SWS_UdpNm_00206
-	-	SWS_UdpNm_00208
-	-	SWS_UdpNm_00210
-	-	SWS_UdpNm_00211
-	-	SWS_UdpNm_00213
-	-	SWS_UdpNm_00214
-	-	SWS_UdpNm_00217
-	-	SWS_UdpNm_00218
-	-	SWS_UdpNm_00219
-	-	SWS_UdpNm_00220
-	-	SWS_UdpNm_00221
-	-	SWS_UdpNm_00222
-	-	SWS_UdpNm_00223
-	-	SWS_UdpNm_00224
-	-	SWS_UdpNm_00226
-	-	SWS_UdpNm_00227
-	-	SWS_UdpNm_00228
-	-	SWS_UdpNm_00229
-	-	SWS_UdpNm_00230
-	-	SWS_UdpNm_00231
-	-	SWS_UdpNm_00232
-	-	SWS_UdpNm_00233
-	-	SWS_UdpNm_00234
-	-	SWS_UdpNm_00237
-	-	SWS_UdpNm_00244
-	-	SWS_UdpNm_00246
-	-	SWS_UdpNm_00247
-	-	SWS_UdpNm_00248
-	-	SWS_UdpNm_00249
-	-	SWS_UdpNm_00304
-	-	SWS_UdpNm_00305
-	-	SWS_UdpNm_00306
-	-	SWS_UdpNm_00307



-	-	SWS_UdpNm_00308
-	-	SWS_UdpNm_00309
-	-	SWS_UdpNm_00310
-	-	SWS_UdpNm_00311
-	-	SWS_UdpNm_00312
-	-	SWS_UdpNm_00313
-	-	SWS_UdpNm_00314
-	-	SWS_UdpNm_00315
-	-	SWS_UdpNm_00316
-	-	SWS_UdpNm_00317
-	-	SWS_UdpNm_00318
-	-	SWS_UdpNm_00320
-	-	SWS_UdpNm_00321
-	-	SWS_UdpNm_00322
-	-	SWS_UdpNm_00324
-	-	SWS_UdpNm_00328
-	-	SWS_UdpNm_00329
-	-	SWS_UdpNm_00331
-	-	SWS_UdpNm_00332
-	-	SWS_UdpNm_00333
-	-	SWS_UdpNm_00335
-	-	SWS_UdpNm_00336
-	-	SWS_UdpNm_00337
-	-	SWS_UdpNm_00338
-	-	SWS_UdpNm_00339
-	-	SWS_UdpNm_00344
-	-	SWS_UdpNm_00345
-	-	SWS_UdpNm_00347
-	-	SWS_UdpNm_00348
-	-	SWS_UdpNm_00349
-	-	SWS_UdpNm_00351
-	-	SWS_UdpNm_00352
-	-	SWS_UdpNm_00355
-	-	SWS_UdpNm_00357
-	-	SWS_UdpNm_00358
-	-	SWS_UdpNm_00359
-	-	SWS_UdpNm_00360
-	-	SWS_UdpNm_00361
-	-	SWS_UdpNm_00362

-	-	SWS_UdpNm_00363
-	-	SWS_UdpNm_00364
-	-	SWS_UdpNm_00365
-	-	SWS_UdpNm_00366
-	-	SWS_UdpNm_00367
-	-	SWS_UdpNm_00371
-	-	SWS_UdpNm_00372
-	-	SWS_UdpNm_00374
-	-	SWS_UdpNm_00375
-	-	SWS_UdpNm_00376
BSW	-	SWS_UdpNm_00999
BSW00434	-	SWS_UdpNm_00999
BSW136	-	SWS_UdpNm_00999
BSW139	-	SWS_UdpNm_00999
BSW140	-	SWS_UdpNm_00999
SRS_BSW_00005	Modules of the $\hat{\mu}$ C Abstraction Layer (MCAL) may not have hard coded horizontal interfaces	SWS_UdpNm_00999
SRS_BSW_00006	The source code of software modules above the $\hat{\mu}$ C Abstraction Layer (MCAL) shall not be processor and compiler dependent.	SWS_UdpNm_00999
SRS_BSW_00010	The memory consumption of all Basic SW Modules shall be documented for a defined configuration for all supported platforms.	SWS_UdpNm_00999
SRS_BSW_00158	All modules of the AUTOSAR Basic Software shall strictly separate configuration from implementation	SWS_UdpNm_00044, SWS_UdpNm_00081
SRS_BSW_00160	Configuration files of AUTOSAR Basic SW module shall be readable for human beings	SWS_UdpNm_00999
SRS_BSW_00161	The AUTOSAR Basic Software shall provide a microcontroller abstraction layer which provides a standardized interface to higher software layers	SWS_UdpNm_00999
SRS_BSW_00162	The AUTOSAR Basic Software shall provide a hardware abstraction layer	SWS_UdpNm_00999
SRS_BSW_00164	The Implementation of interrupt service routines shall be done by the Operating System, complex drivers or modules	SWS_UdpNm_00999
SRS_BSW_00168	SW components shall be tested by a function defined in a common API in the Basis-SW	SWS_UdpNm_00999
SRS_BSW_00170	The AUTOSAR SW Components shall provide information about their dependency from faults, signal qualities, driver demands	SWS_UdpNm_00999
SRS_BSW_00172	The scheduling strategy that is built inside the Basic Software Modules shall be compatible with the strategy used in the system	SWS_UdpNm_00999
SRS_BSW_00301	All AUTOSAR Basic Software Modules shall only import the necessary information	SWS_UdpNm_00082, SWS_UdpNm_00083
SRS_BSW_00302	All AUTOSAR Basic Software Modules shall only	SWS_UdpNm_00044

	export information needed by other modules	
SRS_BSW_00305	Data types naming convention	SWS_UdpNm_00999
SRS_BSW_00306	AUTOSAR Basic Software Modules shall be compiler and platform independent	SWS_UdpNm_00999
SRS_BSW_00307	Global variables naming convention	SWS_UdpNm_00999
SRS_BSW_00308	AUTOSAR Basic Software Modules shall not define global data in their header files, but in the C file	SWS_UdpNm_00081
SRS_BSW_00309	All AUTOSAR Basic Software Modules shall indicate all global data with read-only purposes by explicitly assigning the const keyword	SWS_UdpNm_00999
SRS_BSW_00312	Shared code shall be reentrant	SWS_UdpNm_00999
SRS_BSW_00314	All internal driver modules shall separate the interrupt frame definition from the service routine	SWS_UdpNm_00999
SRS_BSW_00321	The version numbers of AUTOSAR Basic Software Modules shall be enumerated according specific rules	SWS_UdpNm_00999
SRS_BSW_00325	The runtime of interrupt service routines and functions that are running in interrupt context shall be kept short	SWS_UdpNm_00999
SRS_BSW_00326	-	SWS_UdpNm_00999
SRS_BSW_00328	All AUTOSAR Basic Software Modules shall avoid the duplication of code	SWS_UdpNm_00999
SRS_BSW_00330	It shall be allowed to use macros instead of functions where source code is used and runtime is critical	SWS_UdpNm_00999
SRS_BSW_00331	All Basic Software Modules shall strictly separate error and status information	SWS_UdpNm_00999
SRS_BSW_00333	For each callback function it shall be specified if it is called from interrupt context or not	SWS_UdpNm_00999
SRS_BSW_00334	All Basic Software Modules shall provide an XML file that contains the meta data	SWS_UdpNm_00999
SRS_BSW_00335	Status values naming convention	SWS_UdpNm_00999
SRS_BSW_00336	Basic SW module shall be able to shutdown	SWS_UdpNm_00999
SRS_BSW_00341	Module documentation shall contains all needed informations	SWS_UdpNm_00999
SRS_BSW_00345	BSW Modules shall support pre-compile configuration	SWS_UdpNm_00044
SRS_BSW_00346	All AUTOSAR Basic Software Modules shall provide at least a basic set of module files	SWS_UdpNm_00044, SWS_UdpNm_00081
SRS_BSW_00347	A Naming separation of different instances of BSW drivers shall be in place	SWS_UdpNm_00999
SRS_BSW_00348	All AUTOSAR standard types and constants shall be placed and organized in a standard type header file	SWS_UdpNm_00082
SRS_BSW_00353	All integer type definitions of target and compiler specific scope shall be placed and organized in a single type header	SWS_UdpNm_00082

SRS_BSW_00361	All mappings of not standardized keywords of compiler specific scope shall be placed and organized in a compiler specific type and keyword header	SWS_UdpNm_00082
SRS_BSW_00370	-	SWS_UdpNm_00044
SRS_BSW_00375	Basic Software Modules shall report wake-up reasons	SWS_UdpNm_00999
SRS_BSW_00377	A Basic Software Module can return a module specific types	SWS_UdpNm_00999
SRS_BSW_00381	The pre-compile time parameters shall be placed into a separate configuration header file	SWS_UdpNm_00044
SRS_BSW_00383	The Basic Software Module specifications shall specify which other configuration files from other modules they use at least in the description	SWS_UdpNm_00083
SRS_BSW_00387	-	SWS_UdpNm_00999
SRS_BSW_00410	Compiler switches shall have defined values	SWS_UdpNm_00999
SRS_BSW_00412	References to c-configuration parameters shall be placed into a separate h-file	SWS_UdpNm_00044
SRS_BSW_00413	An index-based accessing of the instances of BSW modules shall be done	SWS_UdpNm_00999
SRS_BSW_00415	Interfaces which are provided exclusively for one module shall be separated into a dedicated header file	SWS_UdpNm_00999
SRS_BSW_00416	The sequence of modules to be initialized shall be configurable	SWS_UdpNm_00999
SRS_BSW_00417	Software which is not part of the SW-C shall report error events only after the DEM is fully operational.	SWS_UdpNm_00999
SRS_BSW_00419	If a pre-compile time configuration parameter is implemented as "const" it should be placed into a separate c-file	SWS_UdpNm_00081
SRS_BSW_00423	BSW modules with AUTOSAR interfaces shall be describable with the means of the SW-C Template	SWS_UdpNm_00999
SRS_BSW_00424	BSW module main processing functions shall not be allowed to enter a wait state	SWS_UdpNm_00999
SRS_BSW_00425	The BSW module description template shall provide means to model the defined trigger conditions of schedulable objects	SWS_UdpNm_00999
SRS_BSW_00426	BSW Modules shall ensure data consistency of data which is shared between BSW modules	SWS_UdpNm_00999
SRS_BSW_00427	ISR functions shall be defined and documented in the BSW module description template	SWS_UdpNm_00999
SRS_BSW_00429	BSW modules shall be only allowed to use OS objects and/or related OS services	SWS_UdpNm_00999
SRS_BSW_00432	Modules should have separate main processing functions for read/receive and write/transmit data path	SWS_UdpNm_00999
SRS_Nm_00046	It shall be possible to trigger the startup of all Nodes at any Point in Time.	SWS_UdpNm_00999

SRS_Nm_00050	The NM shall provide the current state of NM	SWS_UdpNm_00999
SRS_Nm_00052	The NM interface shall signal to the application that all other ECUs are ready to sleep.	SWS_UdpNm_00999
SRS_Nm_00054	There shall be a deterministic time from the point where all nodes agree to go to bus sleep to the point where bus is switched off.	SWS_UdpNm_00999
SRS_Nm_00142	NM shall guarantee an upper limit for the bus load generated by NM itself.	SWS_UdpNm_00999
SRS_Nm_00144	NM shall support communication clusters of up to 64 ECUs	SWS_UdpNm_00999
SRS_Nm_00147	The NM algorithm shall be processor independent.	SWS_UdpNm_00999
SRS_Nm_00151	The Network Management algorithm shall allow any node to integrate into an already running NM cluster	SWS_UdpNm_00999
SRS_Nm_00153	The Network Management shall optionally provide a possibility to detect present nodes	SWS_UdpNm_00999
SRS_Nm_00154	The Network Management API shall be independent from the communication bus	SWS_UdpNm_00999
SRS_Nm_02509	The NM interface shall signal to the application that at least one other ECUs is not ready to sleep anymore.	SWS_UdpNm_00999
SRS_Nm_02512	The NM shall give the possibility to enable or disable the network management related communication configured for an active NM node	SWS_UdpNm_00215, SWS_UdpNm_00216

## 7 Functional specification

### 7.1 Coordination algorithm

The AUTOSAR UdpNm is based on decentralized direct network management strategy, which means that every network node performs activities self-sufficient depending only on the UDP packets received and/or transmitted within the communication system.

The AUTOSAR UdpNm coordination algorithm is based on periodic NM packets, which are received by all nodes in the cluster via broadcast transmission. Reception of NM packets indicates that sending nodes want to keep the NM-cluster awake. If any node is ready to go to the Bus-Sleep Mode, it stops sending NM packets, but as long as NM packets from other nodes are received, it postpones transition to the Bus-Sleep Mode. Finally, if a dedicated timer elapses because no NM packets are received anymore, every node initiates transition to the Bus-Sleep Mode. If any node in the NM-cluster requires bus-communication, it can keep the NM-cluster awake by transmitting NM packets. For more details concerning the wakeup procedure itself, please refer to [10].

The main concept of the AUTOSAR UdpNm coordination algorithm can be defined by the following two key-requirements:

[SWS\_UdpNm\_00087] [ Every network node shall transmit periodic NM PDUs as long as it requires bus-communication; otherwise it shall not transmit NM PDUs. ] ()

[SWS\_UdpNm\_00088] [ If bus communication is released and there are no NM PDUs on the bus for a configurable amount of time, determined by `UDPNM_TIMEOUT_TIME` + `UDPNM_WAIT_BUS_SLEEP_TIME` (both configuration parameters), transition into the Bus-Sleep Mode shall be performed. ] ()

The overall state machine of the AUTOSAR UdpNm coordination algorithm can be defined as follows:

[SWS\_UdpNm\_00089] [ The AUTOSAR UdpNm state machine shall contain states, transitions and triggers required for the AUTOSAR UdpNm coordination algorithm as seen from the point of view of one single node in the NM cluster. ] ()

**Note: A UML state chart of the AUTOSAR UdpNm state machine from the point of view of one single node in the NM cluster can be found in the API specifications chapter 8**

### 7.2 Operational Modes

This chapter describes the operational modes of the AUTOSAR UdpNm coordination algorithm.

[SWS\_UdpNm\_00092] [ The AUTOSAR UdpNm shall contain three operational modes visible at the modules interface:

Network Mode

Prepare Bus-Sleep Mode

Bus-Sleep Mode ] ( )

[SWS\_UdpNm\_00093] [ Changes of the AUTOSAR UdpNm operational modes shall be signalled to the upper layer by means of call-back functions. ] ( )

### 7.2.1 Network Mode

[SWS\_UdpNm\_00094] [ The Network Mode shall consist of three internal states:

Repeat Message State

Normal Operation State

Ready Sleep State ] ( )

[SWS\_UdpNm\_00095] [ When the Network Mode is entered from Bus-Sleep Mode or Prepare Bus-Sleep Mode, by default, the Repeat Message State shall be entered. ] ( )

[SWS\_UdpNm\_00096] [ When the Network Mode is entered, the NM-Timeout Timer shall be started. ] ( )

[SWS\_UdpNm\_00097] [ When the Network Mode is entered, the UdpNm shall notify the upper layer by calling `Nm_NetworkMode`. ] ( )

[SWS\_UdpNm\_00098] [ Upon successful reception of an NM PDU (call of `UdpNm_SoAdIfRxIndication`) in Network Mode, the NM-Timeout Timer shall be restarted. ] ( )

[SWS\_UdpNm\_00099] [ Upon transmission of an NM PDU (call of `UdpNm_SoAdIfTxConfirmation`) in the Network Mode, the NM-Timeout Timer shall be restarted. ] ( )

Note: As no transmission confirmation is available from the SoAd or the TCP/IP stack it is assumed that each Network Management PDU transmission request results in a successful Network Management PDU transmission.

[SWS\_UdpNm\_00206] [ The NM-Timeout Timer shall be reset every time it is started or restarted. ] ( )

#### 7.2.1.1 Repeat Message State

For nodes that are not in passive mode (refer to chapter 7.7.3) the Repeat Message State ensures, that any transition from Bus-Sleep or Prepare Bus-Sleep to the Network Mode becomes visible for the other nodes on the network. Additionally it

ensures that any node stays active for a minimum amount of time (`UDPNM_REPEAT_MESSAGE_TIME`). Optionally it can be used for detection of present nodes.

[SWS\_UdpNm\_00100] [ When the Repeat Message State is entered from Bus-Sleep Mode, Prepare-Bus-Sleep Mode, Normal Operation State or Ready Sleep State transmission of NM packets shall be (re-) started unless passive mode is enabled. ] ()

[SWS\_UdpNm\_00101] [ When the NM-Timeout Timer expires in the Repeat Message State, the NM-Timeout Timer shall be restarted. ] ()

[SWS\_UdpNm\_00102] [ The NM shall stay in the Repeat Message State for a configurable amount of time determined by the `UDPNM_REPEAT_MESSAGE_TIME` (configuration parameter); after that time the Repeat Message State shall be left. ] ()

[SWS\_UdpNm\_00103] [ When Repeat Message State is left, the Normal Operation State shall be entered, if the network has been requested (see [SWS UdpNm 00104](#)). ] ()

[SWS\_UdpNm\_00106] [ When Repeat Message State is left, the Ready Sleep State shall be entered, if the network has been released (see `SWS_UdpNm_00105`). ] ()

[SWS\_UdpNm\_00107] [ When Repeat Message State is left and the option `UDPNM_NODE_DETECTION_ENABLED` is enabled, the Repeat Message Bit shall be cleared. ] ()

[SWS\_UdpNm\_00137] [ If the service `UdpNm_RepeatMessageRequest` is called in Repeat Message State, Prepare Bus-Sleep Mode or Bus-Sleep Mode, the `UdpNm` module shall not execute the service and return `E_NOT_OK`. ] ()

### 7.2.1.2 Normal Operation State

The Normal Operation State ensures that any node can keep the NM-cluster awake as long as the network functionality is required.

[SWS\_UdpNm\_00116] [ When the Normal Operation State is entered from Ready Sleep State, transmission of NM PDUs shall be started unless passive mode is enabled or the NM message transmission ability has been disabled. ] ()

[SWS\_UdpNm\_00117] [ When the NM-Timeout Timer expires in the Normal Operation State, the NM-Timeout Timer shall be restarted. ] ()

[SWS\_UdpNm\_00118] [ When the network is released and the current state is Normal Operation State, the Normal Operation State shall be left and the Ready Sleep state shall be entered (refer to [SWS UdpNm 00105](#)). ] ()



[SWS\_UdpNm\_00119] [ At Repeat Message Request Bit Indication in the Normal Operation State, the Normal Operation State shall be left and the Repeat Message State shall be entered. ] ()

[SWS\_UdpNm\_00120] [ At Repeat Message Request (UdpNm\_RepeatMessageRequest) in the Normal Operation State, the Normal Operation State shall be left and the Repeat Message State shall be entered. ] ()

[SWS\_UdpNm\_00121] [ At Repeat Message Request (UdpNm\_RepeatMessageRequest) in Normal Operation State the Repeat Message Bit shall be set. ] ()

### 7.2.1.3 Ready Sleep State

The Ready Sleep State ensures that any node in the NM-cluster waits with transition to the Prepare Bus-Sleep Mode as long as any other node keeps the NM-cluster awake.

[SWS\_UdpNm\_00108] [ When the Ready Sleep State is entered from Repeat Message State or Normal Operation State, transmission of NM PDUs shall be stopped. ] ()

Note: If passive mode is enabled no NM PDUs are transmitted, no action is required.

[SWS\_UdpNm\_00109] [ When the NM-Timeout Timer expires in the Ready Sleep State, the Ready Sleep State shall be left and the Prepare Bus-Sleep Mode shall be entered. ] ()

[SWS\_UdpNm\_00110] [ When the network is requested and the current state is the Ready Sleep State, the Ready Sleep State shall be left and the Normal Operation State shall be entered (refer to [SWS\\_UdpNm\\_00104](#)). ] ()

[SWS\_UdpNm\_00111] [ At Repeat Message Request Bit Indication in the Ready Sleep State, the Ready Sleep State shall be left and the Repeat Message State shall be entered. ] ()

[SWS\_UdpNm\_00112] [ At Repeat Message Request (UdpNm\_RepeatMessageRequest) in the Ready Sleep State, the Ready Sleep State shall be left and the Repeat Message State shall be entered. ] ()

[SWS\_UdpNm\_00113] [ At Repeat Message Request (UdpNm\_RepeatMessageRequest) in Ready Sleep State the Repeat Message Bit shall be set. ] ()

### 7.2.2 Prepare Bus-Sleep Mode

The purpose of the Prepare Bus Sleep state is to ensure that all nodes have time to stop their network activity before the Bus Sleep state is entered. Bus activity is calmed down (i.e. queued messages are transmitted in order to empty all Tx-buffers) and finally there is no activity on the bus in the Prepare Bus-Sleep Mode.

[SWS\_UdpNm\_00114] [ When Prepare Bus-Sleep Mode is entered, the UdpNm shall notify the upper layer by calling `Nm_PrepareBusSleepMode`. ] ()

[SWS\_UdpNm\_00115] [ The NM shall stay in the Prepare Bus-Sleep Mode for a configurable amount of time determined by the `UDPNM_WAIT_BUS_SLEEP_TIME` (configuration parameter); after that time the Prepare Bus-Sleep Mode shall be left and the Bus-Sleep Mode shall be entered. ] ()

[SWS\_UdpNm\_00124] [ Upon successful reception of an NM PDU in the Prepare Bus-Sleep Mode, the Prepare Bus-Sleep Mode shall be left and the Network Mode shall be entered; by default the Repeat Message State is entered (refer to SWS\_UdpNm\_00095). ] ()

[SWS\_UdpNm\_00123] [ When the network is requested in the Prepare Bus-Sleep Mode, the Prepare Bus-Sleep Mode shall be left and the Network Mode shall be entered; by default the Repeat Message State is entered (refer to SWS\_UdpNm\_00095). ] ()

[SWS\_UdpNm\_00122] [ When the network has been requested in the Prepare Bus-Sleep Mode and the UdpNm module has entered Network Mode and if `UDPNM_IMMEDIATE_RESTART_ENABLED` (configuration parameter) is `TRUE`, the UdpNm module shall transmit a Network Management PDU. ] ()

Rationale: Other nodes in the cluster are still in Prepare Bus-Sleep Mode; in the exceptional situation described above transition into the Bus-Sleep Mode shall be avoided and bus-communication shall be restored as fast as possible.

Caused by the transmission offset for Network Management PDUs in UdpNm, the transmission of the first Network Management PDU in Repeat Message State can be delayed significantly. In order to avoid a delayed re-start of the network the transmission of a Network Management PDU can be requested immediately.

Note: If `UDPNM_IMMEDIATE_RESTART_ENABLED` is `TRUE` and a wake-up line is used, a burst of Network Management PDUs occurs if all network nodes get a network request in Prepare Bus-Sleep Mode.

### 7.2.3 Bus-Sleep Mode

The purpose of the Bus-Sleep state is to reduce power consumption in the node, when no messages are to be exchanged.

The communication controller is switched to sleep mode, respective wakeup mechanisms are activated and finally power consumption is reduced to the adequate level in the Bus-Sleep Mode.

If a configurable amount of time determined by the `UDPNM_TIMEOUT_TIME` + `UDPNM_WAIT_BUS_SLEEP_TIME` (both configuration parameters) is identically configured for all nodes in the network management cluster, all nodes in the network management cluster that are coordinated with use of the AUTOSAR NM algorithm perform the transition into the Bus-Sleep Mode at approximately the same time.

Note: The parameters `UDPNM_TIMEOUT_TIME` and `UDPNM_WAIT_BUS_SLEEP_TIME` should have the same values within all network nodes of the NM-cluster.

Depending on the specific implementation, transition into the Bus-Sleep Mode takes place approximately at the same time. The time jitter experienced for this transition depends on the following factors:

- internal clock precision (oscillator's drift),
- NM-task cycle time (if tasks are not synchronized with a global time),
- NM PDUs waiting time in the Tx-queue (if transmission confirmation is made immediately after transmit request).

For a best case estimation only oscillator drift should be taken into account for a configurable amount of time determined by the value `UDPNM_TIMEOUT_TIME` + `UDPNM_WAIT_BUS_SLEEP_TIME` (both configuration parameters).

[SWS\_UdpNm\_00126] [ When Bus-Sleep Mode is entered, the UdpNm shall notify the upper layer by calling `Nm_BusSleepMode`; this shall not be the case if Bus-Sleep Mode is entered by default at initialization. ] ()

[SWS\_UdpNm\_00127] [ When the UdpNm module receives successfully Network Management PDU in the Bus-Sleep Mode (call of `UdpNm_SoAdIfRxIndication`), the UdpNm module shall notify the upper layer by calling the callback function `Nm_NetworkStartIndication`. ] ()

Rationale: To avoid race conditions and state inconsistencies between Network and Mode Management, UdpNm will not automatically perform the transition from Bus-Sleep Mode to Network Mode. UdpNm will only inform the upper layers which have to make the wake-up decision. NM packet reception in Bus-Sleep Mode must be handled depending on the current state of the ECU shutdown or startup process.

[SWS\_UdpNm\_00128] [ If `UdpNm_PassiveStartUp` is called in the Bus-Sleep Mode or Prepare Bus Sleep Mode, the UdpNm module shall enter the Network Mode; by default the Repeat Message State is entered (refer to [SWS UdpNm 00095](#) and [SWS UdpNm 00104](#)). ] ()

Note: In the Prepare Bus-Sleep Mode and Bus-Sleep Mode is assumed that the network is released, unless bus communication is explicitly requested.

[SWS\_UdpNm\_00129]: [ When the network is requested in Bus-Sleep Mode, the UdpNm module shall enter the Network Mode; by default the UdpNm module shall enter the Repeat Message State (refer to [SWS UdpNm 00095](#) and [SWS UdpNm 00104](#)).] ()

### 7.3 Network states

Network states (i.e. ‘requested’ and ‘released’) are two additional states of the AUTOSAR UdpNm state machine that exist in parallel to the state machine. Network states denote, whether the software components need to communicate on the bus (the network state is then ‘requested’); or whether the software components don’t have to communicate on the bus (the bus network state is then ‘released’); note that if the network is released an ECU may still communicate because some other ECU still request the network.

[SWS\_UdpNm\_00104] [ The function call `UdpNm_NetworkRequest` shall request the network. I.e. the UdpNm module shall change network state to ‘requested’.] ()

[SWS\_UdpNm\_00105] [ The function call `UdpNm_NetworkRelease` shall release the network. I.e. the UdpNm module shall change network state to ‘released’. ] ()

### 7.4 Initialization

[SWS\_UdpNm\_00141] [ After successful initialization the Network Management state shall be set to `NM_STATE_BUS_SLEEP` ] ()

Note: The UdpNm module should be initialized after SoAd is initialized and before any other network management service is called.

[SWS\_UdpNm\_00143] [ When initialized, by default, the UdpNm module shall set the network state to ‘released’. ] ()

[SWS\_UdpNm\_00144] [ When initialized, by default, the UdpNm module shall enter the Bus-Sleep Mode. ] ()

[SWS\_UdpNm\_00145] [ If AUTOSAR UdpNm is not initialized it shall not prohibit bus traffic. ] ()

[SWS\_UdpNm\_00060] [ The function `UdpNm_Init` shall select the active configuration set by means of a configuration pointer parameter being passed (see 8.3.1). ] ()

[SWS\_UdpNm\_00061] [ After initialization the UdpNm Message Cycle Timer shall be stopped. ] ()

Note: No timer (UdpNm Message Cycle Timer) is needed if `UDPNM_PASSIVE_MODE_ENABLED` is `TRUE`, because no NM messages are transmitted by such nodes.

[SWS\_UdpNm\_00033] [ After initialization the transmission of NM messages shall be stopped. ] ()

[SWS\_UdpNm\_00039] [ If UdpNm is not initialized a call of any UdpNm function except `UdpNm_Init` shall be rejected and `E_NOT_OK` shall be returned. If Default Error detection is enabled it shall report `UDPNM_E_NO_INIT` to the Default Error Tracer. ] ()

[SWS\_UdpNm\_00025] [ After initialization each byte of the user data bytes shall be set to `0xFF`. ] ()

[SWS\_UdpNm\_00085] [ After initialization the Control Bit Vector shall be set to `0x00`. ] ()

[SWS\_UdpNm\_00148] [ All instances of UDP NM on different ECUs in one NM cluster shall use the same UDP receive port. ] ()

## 7.5 Execution

### 7.5.1 Processor architecture

[SWS\_UdpNm\_00146] [ The AUTOSAR UdpNm coordination algorithm shall be processor independent, meaning it shall not rely on any processor specific hardware support and thus shall be realizable on any processor architecture that is within the scope of AUTOSAR. ] ()

### 7.5.2 Timing parameters

[SWS\_UdpNm\_00246] [ The configuration parameter `UDPNM_TIMEOUT_TIME` shall determine the AUTOSAR UdpNm timing parameter NM-Timeout Time. ] ()

[SWS\_UdpNm\_00247] [ The configuration parameter `UDPNM_REPEAT_MESSAGE_TIME` shall determine the AUTOSAR UdpNm timing parameter Repeat Message Time. ] ()

[SWS\_UdpNm\_00248] [ The configuration parameter `UDPNM_WAIT_BUS_SLEEP_TIME` shall determine the AUTOSAR UdpNm timing parameter Wait Bus-Sleep Time. ] ()

[SWS\_UdpNm\_00249] [ The optional configuration parameter `UDPNM_REMOTE_SLEEP_IND_TIME` shall determine the AUTOSAR UdpNm timing parameter Remote Sleep Indication Time. ] ()

## 7.6 Communication Scheduling

### 7.6.1 NM Message Transmission

Note: The transmission mechanisms described in this chapter are only relevant if the NM message transmission ability is enabled.

[SWS\_UdpNm\_00072] [ The transmission of NM messages shall be configurable by means of `UDPNM_PASSIVE_MODE_ENABLED` (see chapter 10.2). ] ()

Note: Passive nodes do not transmit NM messages, i.e. they can not actively influence the shut down decision, but they do receive NM message in order to be able to shut down synchronously.

Note: The transmission mechanisms described in this chapter are only relevant if `UDPNM_PASSIVE_MODE_ENABLED` is FALSE.

[SWS\_UdpNm\_00237] [ The UdpNm module shall provide the periodic transmission mode. In this transmission mode the UdpNm module shall send Network Management PDUs periodically. ] ()

Note: The periodic transmission mode is used in the "Repeat Message State" and "Normal Operation State".

[SWS\_UdpNm\_00005] [ If transmission of NM PDUs has been started, the UdpNm Message Cycle Timer shall be started with `UDPNM_MSG_CYCLE_OFFSET`. ] ()

Note: This mechanism prevents bursts of NM messages.

[SWS\_UdpNm\_00032] [ If transmission of NM PDUs has been started and the UdpNm Message Cycle Timer expires an NM PDU shall be transmitted through the SoAd by calling `SoAd_IfTransmit`. ] ()

[SWS\_UdpNm\_00040] [ If the UdpNm Message Cycle Timer expires it shall be restarted with `UDPNM_MSG_CYCLE_TIME`. ] ()

[SWS\_UdpNm\_00051] [ If transmission of NM PDUs has been stopped the UdpNm Message Cycle Timer shall be canceled. ] ()

## 7.6.2 Reception

If an NM message has been successfully received, the SoAd will call `UdpNm_SoAdIfRxIndication`.

[SWS\_UdpNm\_00035] [ Upon a call of `UdpNm_SoAdIfRxIndication`, the `UdpNm` module shall copy the data of the Network Management PDU referenced in the function parameter to an internal buffer. ] ()

[SWS\_UdpNm\_00037] [ When an NM PDU has been received, the `Nm` function `Nm_PduRxIndication` shall be called, if `UDPNM_PDU_RX_INDICATION_ENABLED` (configuration parameter) is `TRUE`. ] ()

## 7.7 Additional features

### 7.7.1 Detection of Remote Sleep Indication (optional)

The “Remote Sleep Indication” denotes a situation, where a node in Normal Operation State finds all other nodes in the cluster are ready to sleep. The node still in Normal Operation State will still keep the bus awake.

[SWS\_UdpNm\_00149] [ Detection of remote sleep indication shall be statically configurable with use of the `UDPNM_REMOTE_SLEEP_IND_ENABLED` switch (configuration parameter). ] ()

[SWS\_UdpNm\_00150] [ If no NM PDUs are received in the Normal Operation State for a configurable amount of time determined by the `UDPNM_REMOTE_SLEEP_IND_TIME` (configuration parameter), the NM shall notify the Generic Network Management Interface that all other nodes in the cluster are ready to sleep (the so-called ‘Remote Sleep Indication’) by calling `Nm_RemoteSleepIndication`. ] ()

[SWS\_UdpNm\_00151] [ If Remote Sleep Indication has been previously detected and if an NM PDU is received in the Normal Operation State or Ready Sleep State again, the NM shall notify the Generic Network Management Interface that some nodes in the cluster are not ready to sleep anymore (the so-called ‘Remote Sleep Cancellation’) by calling `Nm_RemoteSleepCancellation`. ] ()

[SWS\_UdpNm\_00152] [ If Remote Sleep Indication has been previously detected and if Repeat Message State is entered from Normal Operation State, the NM shall notify the Generic Network Management Interface that some nodes in the cluster are not ready to sleep anymore (the so-called ‘Remote Sleep Cancellation’) by calling `Nm_RemoteSleepCancellation`. ] ()

[SWS\_UdpNm\_00154] [ The NM shall reject a check of Remote Sleep Indication in Bus-Sleep Mode, Prepare Bus-Sleep Mode and Repeat Message State; the service shall not be executed and `E_NOT_OK` shall be returned. ] ()

### 7.7.2 User Data (optional)

[SWS\_UdpNm\_00158] [ Support of NM user data shall be statically configurable using the `UDPNM_USER_DATA_ENABLED` switch (configuration parameter). ] ()

[SWS\_UdpNm\_00159] [ When `UdpNm_SetUserData` is called, the NM user data for NM packets transmitted next on the bus shall be set; operation of setting the NM user data shall guarantee data consistency. ] ()

[SWS\_UdpNm\_00160] [ When `UdpNm_GetUserData` is called, the NM user data contained in the payload of the most recently received NM PDU shall be provided; operation of providing the NM user data shall guarantee data consistency. ] ()

Note: If NM user data is configured it will be sent for sure in the Repeat Message State. In Ready Sleep State the user data will not be sent.

[SWS\_UdpNm\_00312] [ If `UdpNmComUserDataSupport` is enabled the API `UdpNm_SetUserData` shall not be available. ] ()

### 7.7.3 Passive Mode (optional)

In Passive Mode the node is only receiving NM messages but not transmitting any NM messages.

[SWS\_UdpNm\_00161] [ Passive Mode shall be statically configurable with use of the `UDPNM_PASSIVE_MODE_ENABLED` switch (configuration parameter). ] ()

[SWS\_UdpNm\_00162] [ Passive Mode shall be statically configured consistent for all instances within one ECU. ] ()

[SWS\_UdpNm\_00163] [ If Passive Mode is used (configuration parameter `UDPNM_PASSIVE_MODE_ENABLED`) the following options must not be used:

- Bus Synchronization  
(configuration parameter `UDPNM_BUS_SYNCHRONIZATION_ENABLED`)
- Remote Sleep Indication  
(configuration parameter `UDPNM_REMOTE_SLEEP_IND_ENABLED`)
- Node Detection  
(configuration parameter `UDPNM_NODE_DETECTION_ENABLED`) ] ()

### 7.7.4 NM PDU Rx Indication (optional)

[SWS\_UdpNm\_00164] [ At successful reception of a NM PDU the `UdpNm` shall notify the upper layer by calling `Nm_PduRxIndication`. ] ()



Rationale: If any higher software layer needs to retrieve the NM PDU data of every NM PDU it is required to have an Rx Indication. Polling of the NM PDU data could result in loss of received NM PDU data in case of an NM PDU burst.

Note: `UdpNm_SoAdIfRxIndication` is called by `SoAd` upon NM PDU reception.

[SWS\_UdpNm\_00165] [ The optional service `Nm_PduRxIndication` shall be statically configurable. It shall be available if `UDPNM_PDU_RX_INDICATION_ENABLED` is TRUE. ] ()

### 7.7.5 State change notification (optional)

[SWS\_UdpNm\_00166] [ All changes of the AUTOSAR `UdpNm` states shall be notified to the upper layer by calling `Nm_StateChangeNotification` if the callback `Nm_StateChangeNotification` is enabled (configuration parameter `UDPNM_STATE_CHANGE_IND_ENABLED` is TRUE). ] ()

### 7.7.6 Communication Control (optional)

[SWS\_UdpNm\_00168] [ Communication Control shall be statically configurable with use of the `UDPNM_COM_CONTROL_ENABLED` switch (configuration parameter). ] ()

[SWS\_UdpNm\_00169] [ During initialization of the `UdpNm` module, the `UdpNm` module shall enable the Network Management PDU transmission (start the `UdpNm` Message Cycle Timer with `UDPNM_MSG_CYCLE_OFFSET`). ] ()

[SWS\_UdpNm\_00170] [ The optional service `UdpNm_DisableCommunication` shall disable the NM PDU transmission ability. ] ()

Note: The NM coordination algorithm cannot work correctly if NM PDU transmission ability is disabled. Therefore it has to be ensured that the ECU is not shutdown as long as the NM PDU transmission ability is disabled.

If `UdpNm_NetworkRelease` is called and NM PDU transmission ability has been disabled, ECU will shut down. This ensures that ECU can shut down also in case of race conditions (e.g. diagnostic session left shortly before enabling communication) or a wrong usage of communication control.

[SWS\_UdpNm\_00172] [ The optional service `UdpNm_DisableCommunication` shall return `E_NOT_OK`, if the current mode is not Network Mode. ] ()

[SWS\_UdpNm\_00173] [ When the Network Management PDU transmission ability is disabled, the `UdpNm` module shall stop the `UdpNm` Message Cycle Timer in order to stop the transmission of Network Management PDUs. ] ()

[SWS\_UdpNm\_00174] [ When the NM PDU transmission ability is disabled, the NM-Timeout Timer shall be stopped. ] ()

[SWS\_UdpNm\_00175] [ When the NM PDU transmission ability is disabled, the detection of Remote Sleep Indication Timer shall be suspended. ] ()

[SWS\_UdpNm\_00178] [ When the Network Management PDU transmission ability is enabled, the UdpNm module shall start the UdpNm Message Cycle Timer with `UDPNM_MSG_CYCLE_OFFSET` in order to start transmission of Network Management PDUs. ] ()

[SWS\_UdpNm\_00179] [ When the NM PDU transmission ability is enabled, the NM-Timeout Timer shall be restarted. ] ()

[SWS\_UdpNm\_00180] [ When the NM PDU transmission ability is enabled, the detection of Remote Sleep Indication Timer shall be resumed. ] ()

[SWS\_UdpNm\_00181] [ The optional service `UdpNm_RequestBusSynchronization` shall return `E_NOT_OK` if the NM PDU transmission ability is disabled. ] ()

### 7.7.7 NM Coordinator synchronization support (optional)

When having more than one coordinator connected to the same bus a special bit in the CBV, the `NmCoordinatorSleepReady` bit is used to indicate that the main coordinator requests to start shutdown sequence. The main functionality of the algorithm is described in the Nm module.

[SWS\_UdpNm\_00320] [ If the UdpNm called `NM_CoordReadyToSleepIndication` and is still in Network Mode it shall notify the Nm by calling `Nm_CoordReadyToSleepCancellation` on the first reception of a NM message with the `NmCoordinatorSleepReady` bit (see CBV) set it to 0 ] ()

[SWS\_UdpNm\_00364] [ If UdpNm has entered Network mode or called `Nm_CoordReadyToSleepCancellation` before it shall notify the NM by calling `Nm_CoordReadyToSleepIndication` on the first reception of NM message with the `NmCoordinatorSleepReady` bit (see CBV) set to 1 ] ()

[SWS\_UdpNm\_00321] [ The `NmCoordinatorSleepReady` bit in the CBV shall be set by the API `UdpNm_SetSleepReadyBit`. ] ()

[SWS\_UdpNm\_00322] [ The API `UdpNm_SetSleepReadyBit()` and the feature "Coordinated Bus Shutdown" shall only be available if `UdpNmCoordinatorSyncSupport` is set to `TRUE`. ] ()

## 7.8 Partial Networking

### 7.8.1 Rx Handling of NM PDUs

[SWS\_UdpNm\_00328] [ If the `UdpNmPnEnabled` is `FALSE`, the `UdpNm` shall perform the normal Rx Indication handling and the partial networking extensions shall be disabled.] ()

[SWS\_UdpNm\_00329] [ If `UdpNmPnEnabled` is `TRUE`, the PNI bit in the received NM-PDU is 0, the `UdpNm` module shall perform the normal Rx Indication handling omitting the extensions for partial networking.] ()

[SWS\_UdpNm\_00331] [ If `UdpNmPnEnabled` is `TRUE` and the PNI bit in the received NM-PDU is 1, `UdpNm` module shall process the Partial Networking Information of the NM-PDU as described in chapter 7.8.3 to 7.8.5.] ()

### 7.8.2 Tx Handling of NM PDUs

[SWS\_UdpNm\_00332] [ If `UdpNmPnEnabled` is `TRUE` the `UdpNm` module shall set the value of the transmitted PNI bit in the CBV to 1.] ()

**Note:** The usage of the CBV is mandatory in case Partial Networking is used.

[SWS\_UdpNm\_00333] [ If `UdpNmPnEnabled` is `FALSE` the `UdpNm` module shall set the value of the transmitted PNI bit in the CBV always to 0.] ()

### 7.8.3 NM PDU Filter Algorithm

[SWS\_UdpNm\_00335] [ The range (in bytes) that contains the PN request information (PN Info Range) in the received NM-PDU is defined by `UdpNmPnInfoOffset` (in bytes) starting from byte 0 and `UdpNmPnInfoLength` (in bytes). This range is called PN Info Range.] ()

**Example:**

- `UdpNmPnInfoOffset` = 3
- `UdpNmPnInfoLength` = 2

Only Byte 3 and Byte 4 of the NM message contains PN request information

[SWS\_UdpNm\_00336] [ Every bit of the PN Info Range represents one Partial Network. If the bit is set to 1 the Partial Network is requested. If the bit is set to 0 there is no request for this PN.] ()

[SWS\_UdpNm\_00337] [ By means of the configuration parameter `UdpNmPnFilterMaskByte` the `UdpNm` is able to detect which PN is relevant for the ECU and which not.

Each bit of `UdpNmPnFilterMaskByte` has the following meaning:

- 0 The PN request is irrelevant for the ECU. The communication stack of the ECU is not kept awake if this bit is set in a received NM-PDU.
- 1 The PN request is relevant for the ECU. The communication stack of the ECU is kept awake if this bit is set in a received NM-PDU.] ()

[SWS\_UdpNm\_00338] [ Each PN filter mask byte shall be mapped (bitwise AND)to the corresponding byte in the PN info range of the NM message. ] ()

[SWS\_UdpNm\_00339][ If at least one bit within the PN Info Range of the received NM-PDU matches with a bit in the NM filter mask the PN request information is relevant for the ECU] ()

#### 7.8.4 Aggregation of Internal and External Requested Partial Networks

**Note:** This feature is used by every ECU that has to switch I-PDU-Groups because of the activity of partial networks. (e.g. to prevent false timeouts) I-PDU-Groups shall be switched on if the corresponding PN is requested internally or externally. I-PDU-Groups shall not be switched off until all internal and external requests for the corresponding PN are released.

The logic for switching the IPDU-Groups is implemented by ComM. The `UdpNm` only provides the information if a PN is requested or not. The COM module is used to transfer the data to the upper layers.

To switch the I-PDU-Groups synchronously on all direct connected ECUs, `UdpNm` shall provide the information of a request change to the upper layer at (almost) the same time on every ECU. This is why the reset timer is restarted on every received and every sent NM message (see below).

The aggregated state of the internal/external requested PNs is called External Internal Requests Aggregated (EIRA).

[SWS\_UdpNm\_00344] [ If `UdpNmPnEiraCalcEnabled` is TRUE, the `UdpNm` shall provide the possibility to store external and internal requested PNs combined over all relevant channels (all `UdpNm` Channels where `UdpNmPnEnabled` is TRUE). At initialization the values of all PNs shall be set to 0 (not requested) ] ()

[SWS\_UdpNm\_00347] [ If

- `UdpNmPnEiraCalcEnabled` is TRUE
- a NM-PDU is received
- PNs are requested within this message (bits are set to 1)

- And the requested PNs are set to 1 within the [configured PN filter mask] then UdpNm shall store the request information (value 1) for these PNs ] ( )

[SWS\_UdpNm\_00348] [ If

- UdpNmPnEiraCalcEnabled is TRUE
- NM-PDU is being requested to send by UdpNM
- PNs are requested within this message(bits are set to 1)
- And the requested PNs are set to 1 within the [configured PN filter mask] then UdpNm shall store the request information (value 1) for these PNs.] ( )

[SWS\_UdpNm\_00345] [ If UdpNmPnEiraCalcEnabled is TRUE, the UdpNm module shall provide a possibility to monitor each PN, if this PN is still externally or internally requested on at least one of the relevant channels.] ( )

**Note:** This means, only one timer is required to handle one PN on multiple connected physical channels. For example: only 8 EIRA reset timers are required to handle the requests of a Gateway with 6 physical channels and 8 partial networks. This is possible because the switch of PN PDU-Groups is done global for the ECU and not dependent of the physical channel.

[SWS\_UdpNm\_00349] [ If UdpNmPnEiraCalcEnabled is TRUE and a PN is requested by message reception or sending (see [SWS UdpNM\\_00347](#) and [SWS UdpNm\\_00348](#)) the monitoring for this PN shall be restarted with respect to UdpNmPnResetTime.] ( )

**Note:** UdpNmPnResetTime shall be configured to a value greater than UdpNmMsgCycleTime. If UdpNmPnResetTime is configured to a value smaller than UdpNmMsgCycleTime and only one ECU requests the PN, the request state toggles in the EIRA because request state is reset before the requesting ECU is able to send the next NM message.

**Note:** UdpNmPnResetTime shall be configured to a value smaller than UdpNmTimeoutTime to avoid that the timer could elapse after NM already changed to Prepare Bus Sleep.

[SWS\_UdpNm\_00351] [ If UdpNmPnEiraCalcEnabled is TRUE and a PN is not requested again within UdpNmPnResetTime the corresponding stored value for this PN shall be set to 0 (not requested) ] ( )

[SWS\_UdpNm\_00352] [ If UdpNmPnEiraCalcEnabled is TRUE and the stored value for a PN is set to requested or back to not requested (see [SWS UdpNm\\_00347](#), [SWS UdpNm\\_00348](#) and [SWS UdpNm\\_00351](#)) UdpNm shall inform upper layers by calling PduR\_UdpNmRxIndication() for the configured EIRA PDU (i.e changed EIRA information shall be passed to COM). ] ( )

[SWS\_UdpNm\_00372] [ If UdpNmPnEiraCalcEnabled is TRUE and UdpNmPnEraCalcEnabled is TRUE, the PN status information has to be stored separately for both, the EIRA and ERA information (compare [SWS UdpNM 00344](#) and [SWS UdpNM 00355](#)) ] ( )

### 7.8.5 Aggregation of External Requested Partial Networks

**Note:** This feature is used by the Gateways to collect only the external PN requests. The external PN requests are mirrored back to the requesting bus and provided to other (required) physical channels of a central gateway.

In case of a sub gateway the requests bit must not be mirrored back to the requesting physical channel in order to avoid static waking between central- and sub gateways. This logic shall be implemented by the ComM.

The UdpNm module provides the information if the PN is externally requested or not. The COM module is used for data transmission to the upper layer. The aggregated state of the external requested PNs is called “External Requests Aggregated” (ERA).

[SWS\_UdpNm\_00355] [ If UdpNmPnEraCalcEnabled is TRUE, the UdpNM shall provide the possibility to store external requested PNs on each relevant channel. At initialization the values of all PNs shall be set to 0 (not requested) ] ( )

[SWS\_UdpNm\_00357] [ If

- UdpNmPnEraCalcEnabled is TRUE
- a NM-PDU is received
- PNs are requested within this message (bits are set to 1)
- and the requested PNs are set to 1 within the [configured PN filter mask] then UdpNm shall store the request information (value 1) for these PNs ] ( )

[SWS\_UdpNm\_00358] [ If UdpNmPnEraCalcEnabled is TRUE, the UdpNm module shall provide a possibility to monitor each relevant channel and for each PN if this PN is still externally requested.] ( )

**Note:** This means, a separate timer is required to handle one PN on multiple physical channels.

For example: 48 ERA reset timers are required to handle the requests of a gateway with 6 physical channels and 8 partial networks. It is not possible to combine the reset timer like EIRA timers, because the external request mustn't be mirrored back to the requesting bus by a sub gateway. Thus it is required to detect the physical channel that is the source of the request bit.

[SWS\_UdpNm\_00359] [ If UdpNmPnEraCalcEnabled is TRUE and a PN is requested by message reception ( see [SWS UdpNM 00357](#)) the monitoring for this PN shall be restarted with respect to the UdpNmPnResetTime.] ( )

**Note:** `UdpNmPnResetTime` shall be configured to a value greater than `UdpNmMsgCycleTime`. If `UdpNmPnResetTime` is configured to a value smaller than `UdpNmMsgCycleTime` and only one ECU requests the PN, the request state toggles in the ERA because request state is reset before the requesting ECU is able to send the next NM-PDU.

**Note:** `UdpNmPnResetTime` shall be configured to a value smaller than `UdpNmTimeoutTime` to avoid that the timer could elapse after NM already changed to Prepare Bus Sleep.

[SWS\_UdpNm\_00360] [ If `UdpNmPnEraCalcEnabled` is `TRUE` and PN is not requested again within `UdpNmPnResetTime` then the corresponding stored value for this PN shall be set to not requested (value 0)] ()

[SWS\_UdpNm\_00361] [ If `UdpNmPnEraCalcEnabled` is `TRUE` and the stored value for a PN changes to requested or back to not requested (see [SWS\\_UdpNm\\_00357](#) and [SWS\\_UdpNm\\_00360](#)), the `UdpNm` module shall inform the upper layers by calling `PduR_UdpNmRxIndication()` for the configured ERA PDU (i.e. changed ERA information shall be passed to the COM module).] ()

[SWS\_UdpNm\_00371] [ If `UdpNmPnEraCalcEnabled` is `TRUE` and `UdpNmPnEraCalcEnabled` is `TRUE`, the PN status information has to be stored separately for both EIRA and ERA information (compare [SWS\\_UdpNm\\_00355](#)] ()

### 7.8.6 Spontaneous Transmission of NM-PDUs via `UdpNm_NetworkRequest`

[SWS\_UdpNm\_00362] [ If `UdpNm_NetworkRequest` is called, `UdpNmPnHandleMultipleNetworkRequest` is set to `TRUE` and `UdpNm` is in Ready Sleep State, Normal Operation State or Repeat Message State, `UdpNm` shall change to or restart the Repeat Message State] () .

[SWS\_UdpNm\_00363] [ If `UdpNmPnHandleMultipleNetworkRequests` is set to `TRUE` the `UdpNm` feature 'Immediate Transmission' is mandatory. It shall be ensured that `UdpNmImmediateNmTransmissions > 0` is given.  
] ()

**Note:** The PN Control Module (e.G. `ComM`) is responsible to call `UdpNm_NetworkRequest` if the PN request bits changes.

## 7.9 Payload (PDU) Structure

The figure below shows an example for 8 byter PDU length:

	Bit 7	Bit 6	Bit 5	Bit 4	Bit 3	Bit 2	Bit 1	Bit 0
Byte 0	Source Node Identifier (default)							
Byte 1	Control Bit Vector (default)							
Byte 2	User data 0							
Byte 3	User data 1							
Byte 4	User data 2							
Byte 5	User data 3							
...	...							
Byte n	User data n-2							

**Figure 4: NM packet payload (NM PDU) default format.**

[SWS\_UdpNm\_00074] [ The location of the source node identifier shall be configurable by means of `UDPNM_PDU_NID_POSITION` to Byte 0, Byte 1, or off (default: Byte 0). ] ( )

[SWS\_UdpNm\_00075] [ The location of the control Bit vector shall be configurable by means of `UDPNM_PDU_CBV_POSITION` to Byte 0, Byte 1, or off (default: Byte 1). ] ( )

[SWS\_UdpNm\_00076] [ The length of an NM packet shall not exceed the MTU(Maximum Transmission Unit)of the underlying physical transport layer. ] ( )

The figure below describes the format of the Control Bit Vector:

	Bit 7	Bit 6	Bit 5	Bit 4	Bit 3	Bit 2	Bit 1	Bit 0
CBV	Res	PNI Bit	Res	Active Wakeup Bit	NM Coordinator Sleep Ready	Res R3.2 NM Coordinator ID (High Bit)	Res R3.2 NM Coordinator ID (Low Bit)	Repeat Message Request

**Figure 5: Control Bit Vector.**

[SWS\_UdpNm\_00045] [ The Control Bit Vector shall consist of:

Bit 0: Repeat Message Request

0: Repeat Message State not requested

1: Repeat Message State requested

Bit 3 :NM Coordinator Sleep Bit

0: Start of synchronized shutdown is not requested by main coordinator

1: Start of synchronized shutdown is requested by main coordinator

Bit 4 Active Wakeup Bit

0: Node has not woken up the network (passive wakeup)

1: Node has woken up the network (active Wakeup)

- Bit 6 Partial Network Information Bit (PNI)

0: NM message contains no Partial Network request information

1: NM message contains Partial Network request information



Bit 1,2,5,7 are reserved for future extensions  
0 : Disabled / Reserved for future usage ] ()

Note: The Control Bit Vector is initialized with 0x00 during initialization (also refer to [SWS UdpNm\\_00085](#)).

[SWS\_UdpNm\_00013] [ The source node identifier shall be set with the configuration parameter `UDPNM_NODE_ID` unless `UDPNM_PDU_NID_POSITION` is set to off. ] ()

[SWS\_UdpNm\_00135] [ Support of Repeat Message Request Bit and Repeat Message State Request shall be statically configurable with use of the `UDPNM_NODE_DETECTION_ENABLED` switch (configuration parameter). ] ()

[SWS\_UdpNm\_00138] [ The optional service call `UdpNm_GetPduData` shall provide whole payload (Source Node ID, Control Bit Vector and User Data) of the most recently received UDP NM packet. ] ()

[SWS\_UdpNm\_00139] [ The optional service `UdpNm_GetPduData` shall be statically configurable. It shall be available if `UDPNM_NODE_ID_ENABLED` or `UDPNM_NODE_DETECTION_ENABLED` or `UDPNM_USER_DATA_ENABLED` is TRUE. ] ()

[SWS\_UdpNm\_00366] [ If the `UdpNm` performs a state change from `BusSleep` state or `PrepareBusSleep` state to `NetworkMode` due to a call to `UdpNm_NetworkRequest()` (i.e. due to an active wakeup) and `UdpNmActiveWakeupBitEnabled` is TRUE, the `UdpNm` shall set the `ActiveWakeupBit` in the CBV. ] ()

[SWS\_UdpNm\_00367] [ If the `UdpNm` module leaves the `NetworkMode` and `UdpNmActiveWakeupBitEnabled` is TRUE, the `UdpNm` module shall clear the `ActiveWakeupBit` in the CBV. ] ()

## 7.10 Functional requirements on UdpNm API

[SWS\_UdpNm\_00014] [ If the node detection functionality is enabled, the function `Nm_RepeatMessageIndication` shall be called upon every reception of the `RepeatMessageRequest` bit if `UDPNM_REPEAT_MSG_IND_ENABLED` is enabled. ] ()

[SWS\_UdpNm\_00086] [ If `UDPNM_USER_DATA_ENABLED` is enabled and `UDPNM_USER_DATA_LENGTH` is set to 0x00 an error during configuration or compilation time shall be raised. ] ()

## 7.11 Car Wakeup

[SWS\_UdpNm\_00374] If the Car Wakeup bit within any received NM-PDU is 1, `UdpNmCarWakeUpRxEnabled` is TRUE, and `UdpNmCarWakeUpFilterEnabled` is FALSE `UdpNm` shall call `Nm_CarWakeUpIndication` and perform the standard Rx indication handling.] ()

[SWS\_UdpNm\_00375] If `UdpNm_GetPduData` is called in the context of `Nm_CarWakeUpIndication`, `UdpNm` shall return the PDU data of the PDU that causes the call of `Nm_CarWakeUpIndication`.] ()

Note: This is required to enable ECU to identify detail about the sender of the Car Wakeup request

[SWS\_UdpNm\_00376] If `UdpNmCarWakeUpFilterEnabled` is TRUE, the Car Wakeup bit within any received NM-PDU is 1, `UdpNmCarWakeUpRxEnabled` is TRUE and the Node ID in the received NM-PDU is equal to `UdpNmCarWakeUpFilterNodeId` the `UdpNm` module shall call `Nm_CarWakeUpIndication` and perform the standard Rx Indication handling] ()

Note: The Car Wakeup filter is necessary to realize sub gateways that only consider the Car Wakeup of the central Gateway to avoid wrong wakeups

## 7.12 Error Classification

This section describes how the `UdpNm` module has to manage the error classes that may occur during the life cycle of this basic software.

The general requirements document of AUTOSAR [2] specifies that all basic software modules must distinguish (according to the product life cycle) two error types:

**Development errors:** these errors should be detected and fixed during the development phase. In most cases, these errors are software errors. The detection errors that should only occur during development can be switched off for production code (by static configuration, namely preprocessor switches).

**Production errors:** these errors are hardware errors and software exceptions that cannot be avoided and are expected to occur in the production (i.e. series) code. This kind of error is commonly known as a run-time error.

[SWS\_UdpNm\_00223] [ On errors and exceptions, the `UdpNm` module shall not modify its current module state but shall simply report the error event to the DEM. ] ()

In case of production errors, the Diagnostic Event Manager module (via the Function Inhibition Manager) will perform the appropriate action (e.g. status modification of the calling module).

### 7.12.1 Development Errors

[SWS\_UdpNm\_00018] [ The following errors shall be detectable by the UdpNm depending on its build version (development/production mode). ] ()

<b>Type or error</b>	<b>Relevance</b>	<b>Related error code</b>	<b>Error Value</b>
API service used without module initialization	Development	UDPNM_E_NO_INIT	0x01
API service called with wrong channel handle	Development	UDPNM_E_INVALID_CHANNEL	0x02
API service called with wrong PDU ID.	Development	UDP_E_INVALID_PDUID	0x03
UdpNm initialization has failed, e.g. selected configuration set doesn't exist	Development	UDPNM_E_INIT_FAILED	0x04
Null pointer has been passed as an argument	Development	UDPNM_E_PARAM_POINTER	0x12

### 7.12.2 Run Time Errors

<b>Type or error</b>	<b>Related error code</b>	<b>Value [hex]</b>
If the NM-Timeout timer has expired outside Ready Sleep state, i.e either in Repeat Message state or in Normal Operation state	UDPNM_E_NETWORK_TIMEOUT	0x02

### 7.12.3 Transient Faults

The UdpNm module, currently does not specify any Transient Faults

### 7.12.4 Production Errors

The UdpNm module, currently does not specify any Production Errors

### 7.12.5 Extended Production Errors

The UdpNm module, currently does not specify any Extended Production Errors

### 7.12.6 Error detection

For details refer to the chapter 7.3 “Error Detection” in *SWS\_BSWGeneral*.

### 7.12.7 Error notification

[SWS\_UdpNm\_00189] [ Development errors shall not be returned by API functions; in case of a development error, the respective API function will return `E_NOT_OK`, if applicable. ] ()

[SWS\_UdpNm\_00190] [ Production errors shall not be returned by API functions; in case of a production error, the respective API function will return `E_NOT_OK`, if applicable. ] ()

[SWS\_UdpNm\_00191] [ If not initialized, the NM shall reject every API service apart from `UdpNm_Init`; the called function shall not be executed, but instead of that it shall report `UDPNM_E_NO_INIT` to the Default Error Tracer (if development error detection is enabled) and it shall return `E_NOT_OK` to the calling function ] ()

[SWS\_UdpNm\_00192] [ When NM API service with an invalid network handle is called, the called function shall not be executed, but instead of that it shall report `UDPNM_E_INVALID_CHANNEL` to the Default Error Tracer (if development error detection is enabled) otherwise it shall return `E_NOT_OK` to the calling function] ()

Note: The network handle is invalid if it is different from allowed configured values.

[SWS\_UdpNm\_00193] [ When the NM-Timeout Timer expires in the Repeat Message State, the NM shall report `UDPNM_E_NETWORK_TIMEOUT` as Run Time Error] ()

[SWS\_UdpNm\_00194] [ When the NM-Timeout Timer expires in the Normal Operation State, the NM shall report `UDPNM_E_NETWORK_TIMEOUT` as Run Time Error] ()

[SWS\_UdpNm\_00314] [ If `UdpNmComUserDataSupport` is enabled and the `UdpNm User Data` length does not match with the length of the referenced I-PDU an error shall be reported at generation time. ] ()

Note: NULL Pointer checking is specified within BSW General [\[22\]](#)

## 7.13 Scheduling of the main function

For details refer to the chapter 8.5 “Scheduled functions” in *SWS\_BSWGeneral*.

## 7.14 Application notes

### 7.14.1 Wakeup notification

Wakeup notification is defined in detail in the ECU State Manager specification [11].

### 7.14.2 Coordination of coupled networks

[SWS\_UdpNm\_00185] [ Support of bus synchronization on demand shall be statically configurable with use of the `UDPNM_BUS_SYNCHRONIZATION_ENABLED` switch (configuration parameter). ] ()

Note: Since the shutdown of UdpNm can be done at any time, the call of the API `Nm_SynchronizationPoint` is not supported.

### 7.14.3 Debugging Concept

For details refer to the chapter 7.1.17 “Debugging support” in *SWS\_BSWGeneral*.

## 7.15 Version check

For details refer to the chapter 5.1.8 “Version Check” in *SWS\_BSWGeneral*.

## 8 API specification

[SWS\_UdpNm\_00244] [ The UdpNm module shall reject the execution of a service called with an invalid parameter and shall inform the DET. ] ()

AUTOSAR UdpNm API consists of services, which are UDP specific and can be called whenever they are required; each service apart from `UdpNm_Init` refers to one NM channel only.

### 8.1 Imported Types

The following types of `Std_Types.h` are imported:

```
boolean
uint8
uint16
uint32
```

<i>Module</i>	<i>Imported Type</i>
ComStack_Types	NetworkHandleType
	PduldType
	PdulInfoType
Dem	Dem_EventIdType
	Dem_EventStatusType
Nm	Nm_ModeType
	Nm_StateType
Std_Types	Std_ReturnType
	Std_VersionInfoType

### 8.2 Type Definitions

#### 8.2.1 UdpNm\_ConfigType

This type shall contain the parameters of the container `UdpNm_GlobalConfig` and its sub containers.

[SWS\_UdpNm\_00308] [

<b>Name:</b>	UdpNm_ConfigType		
<b>Type:</b>	Structure		
<b>Element:</b>	void	implementation specific	This type shall contain the parameters of the container <code>UdpNm_GlobalConfig</code> and its sub containers.
<b>Description:</b>	--		

] ()

## 8.2.2 UdpNm\_PduPositionType

[SWS\_UdpNm\_00304] [

<b>Name:</b>	UdpNm_PduPositionType	
<b>Type:</b>	Enumeration	
<b>Range:</b>	UDPNM_PDU_BYTE_0	0x00: Byte 0 is used
	UDPNM_PDU_BYTE_1	0x01: Byte 1 is used
	UDPNM_PDU_OFF	0xFF: Node Identification is not used
<b>Description:</b>	Used to define the position of the control bit vector within the NM PACKET.	

] ()

## 8.3 UdpNm Functions called by the Nm

### 8.3.1 UdpNm\_Init

[SWS\_UdpNm\_00208] [

<b>Service name:</b>	UdpNm_Init	
<b>Syntax:</b>	<pre>void UdpNm_Init(     const UdpNm_ConfigType* UdpNmConfigPtr )</pre>	
<b>Service ID[hex]:</b>	0x01	
<b>Sync/Async:</b>	Synchronous	
<b>Reentrancy:</b>	Non Reentrant	
<b>Parameters (in):</b>	UdpNmConfigPtr	Pointer to a selected configuration structure
<b>Parameters (inout):</b>	None	
<b>Parameters (out):</b>	None	
<b>Return value:</b>	None	
<b>Description:</b>	<p>Initialize the complete UdpNm module, i.e. all channels which are activated at configuration time are initialized. A UDP socket shall be set up with the TCP/IP stack.</p> <p>Caveats: This function has to be called after initialization of the TCP/IP stack.</p> <p>Configuration: Mandatory</p>	

] ()

[SWS\_UdpNm\_00210] [ If an error has to be indicated to the DET the value 0x00 shall be used as the instance id. ] ()

*Rationale: the value 0 x 00 is not error value but instance ID*

### 8.3.2 UdpNm\_PassiveStartUp

[SWS\_UdpNm\_00211] [

<b>Service name:</b>	UdpNm_PassiveStartUp	
<b>Syntax:</b>	Std_ReturnType UdpNm_PassiveStartUp( NetworkHandleType nmChannelHandle )	
<b>Service ID[hex]:</b>	0x0e	
<b>Sync/Async:</b>	Asynchronous	
<b>Reentrancy:</b>	Reentrant (but not for the same NM-Channel)	
<b>Parameters (in):</b>	nmChannelHandle	Identification of the NM-channel
<b>Parameters (inout):</b>	None	
<b>Parameters (out):</b>	None	
<b>Return value:</b>	Std_ReturnType	E_OK: No error E_NOT_OK: Passive startup of network management has failed
<b>Description:</b>	Passive startup of the AUTOSAR UdpNm. It triggers the transition from Bus-Sleep Mode or Prepare Bus Sleep Mode to the Network Mode in Repeat Message State.  Caveats: UdpNm is initialized correctly.  Configuration: Mandatory	

] ()

[SWS\_UdpNm\_00147] [ If UdpNm\_PassiveStartUp is called in the Network Mode, the UdpNm module shall not execute this service and shall return E\_NOT\_OK.] ()

### 8.3.3 UdpNm\_NetworkRequest

[SWS\_UdpNm\_00213] [

<b>Service name:</b>	UdpNm_NetworkRequest	
<b>Syntax:</b>	Std_ReturnType UdpNm_NetworkRequest( NetworkHandleType nmChannelHandle )	
<b>Service ID[hex]:</b>	0x02	
<b>Sync/Async:</b>	Asynchronous	
<b>Reentrancy:</b>	Reentrant (but not for the same NM-Channel)	
<b>Parameters (in):</b>	nmChannelHandle	Identification of the NM-channel
<b>Parameters (inout):</b>	None	
<b>Parameters (out):</b>	None	
<b>Return value:</b>	Std_ReturnType	E_OK: No error E_NOT_OK: Requesting of network has failed
<b>Description:</b>	Request the network, since ECU needs to communicate on the bus. Network state shall be changed to 'requested'  Caveats: UdpNm is initialized correctly.  Configuration: Optional (Only available if UDPNM_PASSIVE_MODE_ENABLED is FALSE)	

] ()



### 8.3.4 UdpNm\_NetworkRelease

[SWS\_UdpNm\_00214] [

<b>Service name:</b>	UdpNm_NetworkRelease	
<b>Syntax:</b>	Std_ReturnType UdpNm_NetworkRelease( NetworkHandleType nmChannelHandle )	
<b>Service ID[hex]:</b>	0x03	
<b>Sync/Async:</b>	Asynchronous	
<b>Reentrancy:</b>	Reentrant (but not for the same NM-Channel)	
<b>Parameters (in):</b>	nmChannelHandle	Identification of the NM-channel
<b>Parameters (inout):</b>	None	
<b>Parameters (out):</b>	None	
<b>Return value:</b>	Std_ReturnType	E_OK: No error E_NOT_OK: Releasing of network has failed
<b>Description:</b>	Release the network, since ECU doesn't have to communicate on the bus. Network state shall be changed to 'released'.  Caveats: UdpNm is initialized correctly.  Configuration: Optional (Only available if UDPNM_PASSIVE_MODE_ENABLED is FALSE)	

] ()

### 8.3.5 UdpNm\_DisableCommunication

[SWS\_UdpNm\_00215] [

<b>Service name:</b>	UdpNm_DisableCommunication	
<b>Syntax:</b>	Std_ReturnType UdpNm_DisableCommunication( NetworkHandleType nmChannelHandle )	
<b>Service ID[hex]:</b>	0x0c	
<b>Sync/Async:</b>	Asynchronous	
<b>Reentrancy:</b>	Reentrant (but not for the same NM-Channel)	
<b>Parameters (in):</b>	nmChannelHandle	Identification of the NM-channel
<b>Parameters (inout):</b>	None	
<b>Parameters (out):</b>	None	
<b>Return value:</b>	Std_ReturnType	E_OK: No error E_NOT_OK: Disabling of NM PDU transmission ability has failed
<b>Description:</b>	Disable the NM PDU transmission ability due to a ISO14229 Communication Control (0x28) service  Caveats: UdpNm is initialized correctly.  Configuration: Optional (Only available if UDPNM_COM_CONTROL_ENABLED is defined)	

] (SRS\_Nm\_02512)

[SWS\_UdpNm\_00307] [ If the module operates in passive mode (UDPNM\_PASSIVE\_MODE\_ENABLED) the service UdpNm\_DisableCommunication shall have no effects and shall directly return E\_NOT\_OK. ] ()

### 8.3.6 UdpNm\_EnableCommunication

[SWS\_UdpNm\_00216] [

<b>Service name:</b>	UdpNm_EnableCommunication	
<b>Syntax:</b>	Std_ReturnType UdpNm_EnableCommunication( NetworkHandleType nmChannelHandle )	
<b>Service ID[hex]:</b>	0x0d	
<b>Sync/Async:</b>	Asynchronous	
<b>Reentrancy:</b>	Reentrant (but not for the same NM-Channel)	
<b>Parameters (in):</b>	nmChannelHandle	Identification of the NM-channel
<b>Parameters (inout):</b>	None	
<b>Parameters (out):</b>	None	
<b>Return value:</b>	Std_ReturnType	E_OK: No error E_NOT_OK: Enabling of NM PDU transmission ability has failed
<b>Description:</b>	Enable the NM PDU transmission ability due to a ISO14229 Communication Control (0x28) service  Caveats: UdpNm is initialized correctly.  Configuration: Optional (Only available if UDPNM_COM_CONTROL_ENABLED is TRUE).	

] (SRS\_Nm\_02512)

[SWS\_UdpNm\_00176] [ The optional service `UdpNm_EnableCommunication` shall enable the NM PDU transmission ability if the NM PDU transmission ability is disabled. ] ()

[SWS\_UdpNm\_00177] [ The optional service `UdpNm_EnableCommunication` shall return `E_NOT_OK` if the NM PDU transmission ability is already enabled when the service is called. ] ()

[SWS\_UdpNm\_00305] [ The service `UdpNm_EnableCommunication` shall return `E_NOT_OK`, if the current mode is not Network Mode. ] ()

[SWS\_UdpNm\_00306] [ If the module operates in passive mode (`UDPNM_PASSIVE_MODE_ENABLED` is `TRUE`) the service `UdpNm_EnableCommunication` shall have no effects and shall directly return `E_NOT_OK`. ] ()

### 8.3.7 UdpNm\_SetUserData

[SWS\_UdpNm\_00217] [

<b>Service name:</b>	UdpNm_SetUserData	
<b>Syntax:</b>	<pre>Std_ReturnType UdpNm_SetUserData(     NetworkHandleType nmChannelHandle,     const uint8* nmUserDataPtr )</pre>	
<b>Service ID[hex]:</b>	0x04	
<b>Sync/Async:</b>	Synchronous	
<b>Reentrancy:</b>	Non Reentrant	
<b>Parameters (in):</b>	nmChannelHandle	Identification of the NM-channel
	nmUserDataPtr	Pointer where the user data for the next transmitted NM message shall be copied from.
<b>Parameters (inout):</b>	None	
<b>Parameters (out):</b>	None	
<b>Return value:</b>	Std_ReturnType	<code>E_OK</code> : No error <code>E_NOT_OK</code> : Setting of user data has failed
	<b>Description:</b> Set user data for all NM messages transmitted on the bus after this function has returned without error.  Caveats: UdpNm is initialized correctly.  Configuration: Optional (Only available if <code>UDPNM_USER_DATA_ENABLED</code> is defined and <code>UDPNM_PASSIVE_MODE_ENABLED</code> is <code>FALSE</code> ).	

] ()

### 8.3.8 UdpNm\_GetUserData

[SWS\_UdpNm\_00218] [

<b>Service name:</b>	UdpNm_GetUserData	
<b>Syntax:</b>	Std_ReturnType UdpNm_GetUserData( NetworkHandleType nmChannelHandle, uint8* nmUserDataPtr )	
<b>Service ID[hex]:</b>	0x05	
<b>Sync/Async:</b>	Synchronous	
<b>Reentrancy:</b>	Non Reentrant	
<b>Parameters (in):</b>	nmChannelHandle	Identification of the NM-channel
<b>Parameters (inout):</b>	None	
<b>Parameters (out):</b>	nmUserDataPtr	Pointer where user data out of the most recently received NM message shall be copied to.
<b>Return value:</b>	Std_ReturnType	E_OK: No error E_NOT_OK: Getting of user data has failed
<b>Description:</b>	Get user data from the most recently received NM message.  Caveats: UdpNm is initialized correctly.  Configuration: Optional (Only available if UDPNM_USER_DATA_ENABLED is TRUE).	

] ()

### 8.3.9 UdpNm\_GetNodeIdentifier

[SWS\_UdpNm\_00219] [

<b>Service name:</b>	UdpNm_GetNodeIdentifier	
<b>Syntax:</b>	Std_ReturnType UdpNm_GetNodeIdentifier( NetworkHandleType nmChannelHandle, uint8* nmNodeIdPtr )	
<b>Service ID[hex]:</b>	0x06	
<b>Sync/Async:</b>	Synchronous	
<b>Reentrancy:</b>	Reentrant	
<b>Parameters (in):</b>	nmChannelHandle	Identification of the NM-channel
<b>Parameters (inout):</b>	None	
<b>Parameters (out):</b>	nmNodeIdPtr	Pointer where the source node identifier from the most recently received NM PDU shall be copied to.
<b>Return value:</b>	Std_ReturnType	E_OK: No error E_NOT_OK: Getting of the source node identifier from the most recently received NM PDU has failed
<b>Description:</b>	Get node identifier from the most recently received NM PDU.  Caveats: UdpNm is initialized correctly.  Configuration: Optional (Only available if UDPNM_NODE_ID_ENABLED is TRUE).	

] ()

[SWS\_UdpNm\_00132] [ The optional service call UdpNm\_GetNodeIdentifier shall provide the source node identifier contained in the most recently received NM packet. ] ()

### 8.3.10 UdpNm\_GetLocalNodeIdentifier

[SWS\_UdpNm\_00220] [

<b>Service name:</b>	UdpNm_GetLocalNodeIdentifier	
<b>Syntax:</b>	Std_ReturnType UdpNm_GetLocalNodeIdentifier( NetworkHandleType nmChannelHandle, uint8* nmNodeIdPtr )	
<b>Service ID[hex]:</b>	0x07	
<b>Sync/Async:</b>	Synchronous	
<b>Reentrancy:</b>	Reentrant	
<b>Parameters (in):</b>	nmChannelHandle	Identification of the NM-channel
<b>Parameters (inout):</b>	None	
<b>Parameters (out):</b>	nmNodeIdPtr	Pointer where node identifier of the local node shall be copied to.
<b>Return value:</b>	Std_ReturnType	E_OK: No error E_NOT_OK: Getting of the node identifier of the local node has failed
<b>Description:</b>	Get node identifier configured for the local node.  Caveats: UdpNm is initialized correctly.  Configuration: Optional (Only available if UDPNM_NODE_ID_ENABLED is TRUE).	

] ()

[SWS\_UdpNm\_00133] [ The optional service call UdpNm\_GetLocalNodeIdentifier shall provide the node identifier configured for the local host node. ] ()

### 8.3.11 UdpNm\_RepeatMessageRequest

[SWS\_UdpNm\_00221] [

<b>Service name:</b>	UdpNm_RepeatMessageRequest	
<b>Syntax:</b>	Std_ReturnType UdpNm_RepeatMessageRequest ( NetworkHandleType nmChannelHandle )	
<b>Service ID[hex]:</b>	0x08	
<b>Sync/Async:</b>	Asynchronous	
<b>Reentrancy:</b>	Reentrant (but not for the same NM-Channel)	
<b>Parameters (in):</b>	nmChannelHandle	Identification of the NM-channel
<b>Parameters (inout):</b>	None	
<b>Parameters (out):</b>	None	
<b>Return value:</b>	Std_ReturnType	E_OK: No error E_NOT_OK: Setting of Repeat Message Request Bit has failed
<b>Description:</b>	Set Repeat Message Request Bit for all NM messages transmitted on the bus after this function has returned without error.  Caveats: UdpNm is initialized correctly.  Configuration: Configuration of UdpNm_RepeatMessageRequest: Optional (Only available if UDPNM_NODE_DETECTION_ENABLED is TRUE).	

] ()

### 8.3.12 UdpNm\_GetPduData

[SWS\_UdpNm\_00309] [

<b>Service name:</b>	UdpNm_GetPduData	
<b>Syntax:</b>	Std_ReturnType UdpNm_GetPduData ( NetworkHandleType nmChannelHandle, uint8* nmPduDataPtr )	
<b>Service ID[hex]:</b>	0x0a	
<b>Sync/Async:</b>	Synchronous	
<b>Reentrancy:</b>	Reentrant	
<b>Parameters (in):</b>	nmChannelHandle	Identification of the NM-channel
<b>Parameters (inout):</b>	None	
<b>Parameters (out):</b>	nmPduDataPtr	Pointer where NM PDU shall be copied to.
<b>Return value:</b>	Std_ReturnType	E_OK: No error E_NOT_OK: Getting of NM PDU data has failed
<b>Description:</b>	Get the whole PDU data out of the most recently received NM message.  Caveats: UdpNm is initialized correctly.  Configuration: Optional (Only available if UDPNM_NODE_ID_ENABLED or UDPNM_NODE_DETECTION_ENABLED or UDPNM_USER_DATA_ENABLED is TRUE).	

] ()

### 8.3.13 UdpNm\_GetState

[SWS\_UdpNm\_00310] [

<b>Service name:</b>	UdpNm_GetState	
<b>Syntax:</b>	<pre>Std_ReturnType UdpNm_GetState(     NetworkHandleType nmChannelHandle,     Nm_StateType* nmStatePtr,     Nm_ModeType* nmModePtr )</pre>	
<b>Service ID[hex]:</b>	0x0b	
<b>Sync/Async:</b>	Synchronous	
<b>Reentrancy:</b>	Reentrant	
<b>Parameters (in):</b>	nmChannelHandle	Identification of the NM-channel
<b>Parameters (inout):</b>	None	
<b>Parameters (out):</b>	nmStatePtr	Pointer where state of the network management shall be copied to.
	nmModePtr	Pointer where the mode of the network management shall be copied to.
<b>Return value:</b>	Std_ReturnType	E_OK: No error E_NOT_OK: Getting of NM state has failed
<b>Description:</b>	Returns the state and the mode of the network management.  Caveats: UdpNm is initialized correctly.  Configuration: Mandatory	

] ()

### 8.3.14 UdpNm\_GetVersionInfo

[SWS\_UdpNm\_00224] [

<b>Service name:</b>	UdpNm_GetVersionInfo	
<b>Syntax:</b>	<pre>void UdpNm_GetVersionInfo(     Std_VersionInfoType* versioninfo )</pre>	
<b>Service ID[hex]:</b>	0x09	
<b>Sync/Async:</b>	Synchronous	
<b>Reentrancy:</b>	Reentrant	
<b>Parameters (in):</b>	None	
<b>Parameters (inout):</b>	None	
<b>Parameters (out):</b>	versioninfo	Pointer to where to store the version information of this module.
<b>Return value:</b>	None	
<b>Description:</b>	This service returns the version information of this module.	

] ()

[SWS\_UdpNm\_00318] [ If DET is enabled for the UdpNm module, the function UdpNm\_GetVersionInfo shall raise UDPNM\_E\_PARAM\_POINTER, if the argument versioninfo is a NULL pointer and return without any action. ] ()



### 8.3.15 UdpNm\_RequestBusSynchronization

[SWS\_UdpNm\_00226] [

<b>Service name:</b>	UdpNm_RequestBusSynchronization	
<b>Syntax:</b>	Std_ReturnType UdpNm_RequestBusSynchronization( NetworkHandleType nmChannelHandle )	
<b>Service ID[hex]:</b>	0x14	
<b>Sync/Async:</b>	Asynchronous	
<b>Reentrancy:</b>	Non Reentrant	
<b>Parameters (in):</b>	nmChannelHandle	Identification of the NM-channel
<b>Parameters (inout):</b>	None	
<b>Parameters (out):</b>	None	
<b>Return value:</b>	Std_ReturnType	E_OK: No error E_NOT_OK: Requesting of bus synchronization has failed
<b>Description:</b>	Request bus synchronization.  Caveats: UdpNm is initialized correctly.  Configuration: Optional (only available if UDPNM_BUS_SYNCHRONIZATION_ENABLED is defined and UDPNM_PASSIVE_MODE_ENABLED is not defined).	

] ()

[SWS\_UdpNm\_00130] [ The service call UdpNm\_RequestBusSynchronization shall trigger transmission of a single Network Management PDU if UDPNM\_PASSIVE\_MODE\_ENABLED (configuration parameter) is FALSE. ] ()

Rationale: This service is typically used for supporting the NM gateway extensions.

[SWS\_UdpNm\_00187] [ If UdpNm\_RequestBusSynchronization is called in Bus-Sleep Mode and Prepare Bus-Sleep Mode the UdpNm module shall not execute the service and shall return E\_NOT\_OK. ] ()

### 8.3.16 UdpNm\_CheckRemoteSleepIndication

[SWS\_UdpNm\_00227] [

<b>Service name:</b>	UdpNm_CheckRemoteSleepIndication	
<b>Syntax:</b>	Std_ReturnType UdpNm_CheckRemoteSleepIndication( NetworkHandleType nmChannelHandle, boolean* NmRemoteSleepIndPtr )	
<b>Service ID[hex]:</b>	0x11	
<b>Sync/Async:</b>	Synchronous	
<b>Reentrancy:</b>	Reentrant (but not for the same NM-Channel)	
<b>Parameters (in):</b>	nmChannelHandle	Identification of the NM-channel
<b>Parameters (inout):</b>	None	
<b>Parameters (out):</b>	NmRemoteSleepIndPtr	Pointer where check result of remote sleep indication shall be copied to.
<b>Return value:</b>	Std_ReturnType	E_OK: No error E_NOT_OK: Checking of remote sleep indication bits has failed
<b>Description:</b>	Check if remote sleep indication takes place or not.  Caveats: UdpNm is initialized correctly.  Configuration: Optional (only available if UDPNM_REMOTE_SLEEP_INDICATION_ENABLED is defined)	

] ()

[SWS\_UdpNm\_00153] [ The service call UdpNm\_CheckRemoteSleepIndication shall provide the information about current status of Remote Sleep Indication (i.e. already detected or not). ] ()

### 8.3.17 UdpNm\_SetCoordBits

[SWS\_UdpNm\_00222] [

<b>Service name:</b>	UdpNm_SetCoordBits	
<b>Syntax:</b>	Std_ReturnType UdpNm_SetCoordBits( NetworkHandleType nmChannelHandle, uint8 nmCoordBits )	
<b>Service ID[hex]:</b>	0x12	
<b>Sync/Async:</b>	Synchronous	
<b>Reentrancy:</b>	Reentrant (but not for the same NM-Channel)	
<b>Parameters (in):</b>	nmChannelHandle	Identification of the NM-channel
	nmCoordBits	2 bit value to set the NM coordinator ID in the control bit vector of each NM message (coding as depicted in Figure "Control Bit Vector".)
<b>Parameters (inout):</b>	None	
<b>Parameters (out):</b>	None	
<b>Return value:</b>	Std_ReturnType	E_OK: No error E_NOT_OK: Setting the coordinator ID bits has failed
<b>Description:</b>	Sets the NM coordinator ID in the control bit vector of each NM message.	

] ()

### 8.3.18 UdpNm\_SetSleepReadyBit

[SWS\_UdpNm\_00324] [

<b>Service name:</b>	UdpNm_SetSleepReadyBit	
<b>Syntax:</b>	Std_ReturnType UdpNm_SetSleepReadyBit ( NetworkHandleType nmChannelHandle, boolean nmSleepReadyBit )	
<b>Service ID[hex]:</b>	0x16	
<b>Sync/Async:</b>	Synchronous	
<b>Reentrancy:</b>	Non Reentrant	
<b>Parameters (in):</b>	nmChannelHandle	Identification of the NM-channel
	nmSleepReadyBit	Value written to ReadySleep Bit in CBV
<b>Parameters (inout):</b>	None	
<b>Parameters (out):</b>	None	
<b>Return value:</b>	Std_ReturnType	E_OK: No error E_NOT_OK: Writing of remote sleep indication bit has failed
	<b>Description:</b> Set the NM Coordinator Sleep Ready bit in the Control Bit Vector	

] ()

## 8.4 UdpNm functions called by the SoAd

### 8.4.1 UdpNm\_SoAdIfTxConfirmation

[SWS\_UdpNm\_00228] [

<b>Service name:</b>	UdpNm_SoAdIfTxConfirmation	
<b>Syntax:</b>	void UdpNm_SoAdIfTxConfirmation ( PduIdType TxPduId )	
<b>Service ID[hex]:</b>	0x40	
<b>Sync/Async:</b>	Synchronous	
<b>Reentrancy:</b>	Reentrant for different Pdulds. Non reentrant for the same Pdul.	
<b>Parameters (in):</b>	TxPdul	ID of the I-PDU that has been transmitted.
<b>Parameters (inout):</b>	None	
<b>Parameters (out):</b>	None	
<b>Return value:</b>	None	
<b>Description:</b>	The lower layer communication interface module confirms the transmission of an I-PDU.	

] ()

Note: The callback function `UdpNm_SoAdIfTxConfirmation` is called by the SoAd and is implemented by the UdpNm module.

Note: The callback function `UdpNm_SoAdIfTxConfirmation` is either called on interrupt level (interrupt mode) or on task level (Polling Mode) with respect to the

context.

The value passed to UdpNm via the API parameter `udpNmTxPduId` shall refer to the NM channel handle, i.e. a mapping from PduId to NM channel handle is not necessary.

[SWS\_UdpNm\_00229] [ The callback function `UdpNm_SoAdIfTxConfirmation` shall inform the DET (if enabled), if the function call has failed because of the following reasons:

- Invalid channel handle (`UDPNM_E_INVALID_CHANNEL`)
- UdpNm was not initialized (`UDPNM_E_NO_INIT`) ] ()

[SWS\_UdpNm\_00230] [ If an error has to be indicated to the DET, the callback function `UdpNm_SoAdIfTxConfirmation` shall use the value of UdpNm channel handle as the instance id. ] ()

[SWS\_UdpNm\_00316] [ If `UdpNmComUserDataSupport` is enabled the UdpNm shall call `PduR_UdpNmTxConfirmation` within the message transmission confirmation function `UdpNm_SoAdIfTxConfirmation` called by the SoAd. ] ()

### 8.4.2 UdpNm\_SoAdIfRxIndication

[SWS\_UdpNm\_00231] [

<b>Service name:</b>	UdpNm_SoAdIfRxIndication	
<b>Syntax:</b>	<pre>void UdpNm_SoAdIfRxIndication(     PduIdType RxPduId,     const PduInfoType* PduInfoPtr )</pre>	
<b>Service ID[hex]:</b>	0x42	
<b>Sync/Async:</b>	Synchronous	
<b>Reentrancy:</b>	Reentrant for different PduIds. Non reentrant for the same PduId.	
<b>Parameters (in):</b>	RxPduId	ID of the received I-PDU.
	PduInfoPtr	Contains the length ( <code>SduLength</code> ) of the received I-PDU and a pointer to a buffer ( <code>SduDataPtr</code> ) containing the I-PDU.
<b>Parameters (inout):</b>	None	
<b>Parameters (out):</b>	None	
<b>Return value:</b>	None	
<b>Description:</b>	Indication of a received I-PDU from a lower layer communication interface module.	

] ()

The callback function `UdpNm_SoAdIfRxIndication` called by the SoAd and implemented by the UdpNm module. It is called in case of a receive indication event of the SoAd.

The value passed to UdpNm via the API parameter `udpNmRxPduId` shall refer to the UdpNm channel handle, i.e. a mapping from PduId to UdpNm channel handle is not necessary.

[SWS\_UdpNm\_00232] [ The callback function `UdpNm_SoAdIfRxIndication` shall inform the DET (if enabled), if function call has failed because of the following reasons:

Invalid channel handle (`UDPNM_E_INVALID_CHANNEL`)  
 UdpNm was not initialized (`UDPNM_E_NO_INIT`)  
`udpSduPtr` equals `NULL_PTR` (`UDPNM_E_PARAM_POINTER`)  
 Invalid PDU ID (`UDPNM_E_INVALID_PDUID`) ] ()

[SWS\_UdpNm\_00233] [ If an error has to be indicated to the DET, the callback function `UdpNm_SoAdIfRxIndication` shall use the value of UdpNm channel handle as the instance id. ] ()

## 8.5 UdpNm functions called by the PDU-Router

### 8.5.1 UdpNm\_Transmit

[SWS\_UdpNm\_00313] [

<b>Service name:</b>	UdpNm_Transmit	
<b>Syntax:</b>	<pre>Std_ReturnType UdpNm_Transmit(     PduIdType UdpNmTxPduId,     const PduInfoType* UdpNmSrcPduInfoPtr )</pre>	
<b>Service ID[hex]:</b>	0x15	
<b>Sync/Async:</b>	Synchronous	
<b>Reentrancy:</b>	Reentrant	
<b>Parameters (in):</b>	UdpNmTxPduId	This parameter contains a unique identifier referencing to the PDU Routing Table and thereby specifying the socket to be used for transmission of the data.
	UdpNmSrcPduInfoPtr	A pointer to a structure with socket related data: data length and pointer to a data buffer.
<b>Parameters (inout):</b>	None	
<b>Parameters (out):</b>	None	
<b>Return value:</b>	Std_ReturnType	E_OK: The request has been accepted E_NOT_OK: The request has not been accepted, e.g. due to a still ongoing transmission in the corresponding socket or the to be transmitted message is too long.
<b>Description:</b>	UdpNm_Transmit is implemented as an empty function and shall always return E_OK. The function UdpNm_Transmit is only available if the configuration switch <code>UdpNmComUserDataSupport</code> is enabled.	

] ()

[SWS\_UdpNm\_00315] [ If `UdpNmComUserDataSupport` is enabled the UdpNm implementation shall provide an API `UdpNm_Transmit`. This API shall never be called by PduR as the UdpNm will always query the data by means of

PduR\_UdpNmTriggerTransmit.UdpNm\_Transmit is an empty function returning E\_OK at any time. This requirement is relevant to avoid linker errors as PduR expects this API to be provided. ] ()

[SWS\_UdpNm\_00365] when UdpNm\_Transmit() function returns E\_NOT\_OK. The NM shall use the last transmitted value for NmUserData ] ()

Note:

The transmission of outdated NM data can be avoided by not stopping the IPdu in COM used for NmUserData transmission

## 8.6 Scheduled Functions

### 8.6.1 UdpNm\_MainFunction\_<Instance Id>

[SWS\_UdpNm\_00234] [

<b>Service name:</b>	UdpNm_MainFunction<Instance_Id>
<b>Syntax:</b>	void UdpNm_MainFunction<Instance_Id>(void)
<b>Service ID[hex]:</b>	0x13
<b>Description:</b>	<p>Main function of the UdpNm which processes the algorithm describes in that document. E.g.:</p> <p>UdpNm_MainFunction_0() represents the UdpNm instance for the UDP channel 0 UdpNm_MainFunction_1() represents the UdpNm instance for the UDP channel 1 ...</p> <p>Inform the DET (if enabled) if function call has failed because of the following reasons: UdpNm was not initialized (UDPNM_E_NO_INIT)</p> <p>If an error has to be indicated to the DET the &lt;Instance Id&gt; shall be used as the instance id.</p> <p>Caveats: UdpNm is initialized correctly, i.e. the function shall be robust if one or more channels are not initialized</p> <p>Configuration: Mandatory</p>

] ()

## 8.7 Expected Interfaces

In this chapter all interfaces required from other modules are listed.

### 8.7.1 Mandatory Interfaces

This chapter defines all interfaces which are required to fulfill the core functionality of the module.

<b>API function</b>	<b>Description</b>
Dem_ReportErrorStatus	Queues the reported events from the BSW modules (API is only used by BSW modules). The interface has an asynchronous behavior, because the processing of the event is done within the Dem main function. OBD Events Suppression shall be ignored for this computation.
Nm_BusSleepMode	Notification that the network management has entered Bus-Sleep Mode.
Nm_NetworkMode	Notification that the network management has entered Network Mode.
Nm_NetworkStartIndication	Notification that a NM-message has been received in the Bus-Sleep Mode, what indicates that some nodes in the network have already entered the Network Mode.
Nm_PrepareBusSleepMode	Notification that the network management has entered Prepare Bus-Sleep Mode.
SoAd_IfTransmit	Requests transmission of an I-PDU.

## 8.7.2 Optional Interfaces

This chapter defines all interfaces which are required to fulfill an optional functionality of the module.

<b>API function</b>	<b>Description</b>
Det_ReportError	Service to report development errors.
Nm_CarWakeUpIndication	This function is called by a <Bus>Nm to indicate reception of a CWU request.
Nm_CoordReadyToSleepCancellation	Cancels an indication, when the NM Coordinator Sleep Ready bit in the Control Bit Vector is set back to 0.
Nm_CoordReadyToSleepIndication	Sets an indication, when the NM Coordinator Sleep Ready bit in the Control Bit Vector is set
Nm_PduRxIndication	Notification that a NM message has been received.
Nm_RemoteSleepCancellation	Notification that the network management has detected that not all other nodes on the network are longer ready to enter Bus-Sleep Mode.
Nm_RemoteSleepIndication	Notification that the network management has detected that all other nodes on the network are ready to enter Bus-Sleep Mode.
Nm_RepeatMessageIndication	Service to indicate that an NM message with set Repeat Message Request Bit has been received.
Nm_StateChangeNotification	Notification that the state of the lower layer <BusNm> has changed.
Nm_TxTimeoutException	Service to indicate that an attempt to send an NM message failed.
PduR_UdpNmRxIndication	Indication of a received I-PDU from a lower layer communication interface module.
PduR_UdpNmTriggerTransmit	Within this API, the upper layer module (called module) shall check whether the available data fits into the buffer size reported by PduInfoPtr->SduLength. If it fits, it shall copy its data into the buffer provided by PduInfoPtr->SduDataPtr and update the length of the actual copied data in PduInfoPtr->SduLength. If not, it returns E_NOT_OK without changing PduInfoPtr.
PduR_UdpNmTxConfirmation	The lower layer communication interface module confirms the transmission of an I-PDU.

### 8.7.2.1 Functions of PDU Router

[SWS\_UdpNm\_00317] [ If `UdpNmComUserDataSupport` is enabled the `UdpNm` shall collect the NM User Data from the referenced NM I-PDU by calling `PduR_UdpNmTriggerTransmit` and combine the user data with the further NM bytes each time before it requests the transmission of the corresponding NM message. ] ()

### 8.7.3 Configurable interfaces

Not applicable



#### 8.7.4 Job End Notification

Not applicable

### 8.8 Parameter check

[SWS\_UdpNm\_00196] [ If detection of development errors is enabled by `UDPNM_DEV_ERROR_DETECT` (configuration parameter), validity checks for all input parameters shall be performed for each UDP NM API service call.] ()

[SWS\_UdpNm\_00197] [ Parameter type checking shall be performed at compile time; if types do not match, the compilation process shall be stopped and respective compilation warnings or errors shall be returned as far as supported by the compiler. ] ()

[SWS\_UdpNm\_00198] [ Parameter value check (for parameters of the constant value) shall be performed at configuration time; if the value is invalid, the configuration process shall be stopped and the respective configuration error shall be reported. ] ()

[SWS\_UdpNm\_00199] [ Parameter value check (for parameters of the variable value) shall be performed at execution time; if the value is invalid, execution of a service shall be denied and the respective development error shall be reported. ] ()

**8.9 UML State chart diagram**

The following figure shows an UML state diagram with respect to the API specification. Mode change related transitions are denoted in green, error handling related transitions in red and optional node detection related transitions in blue.

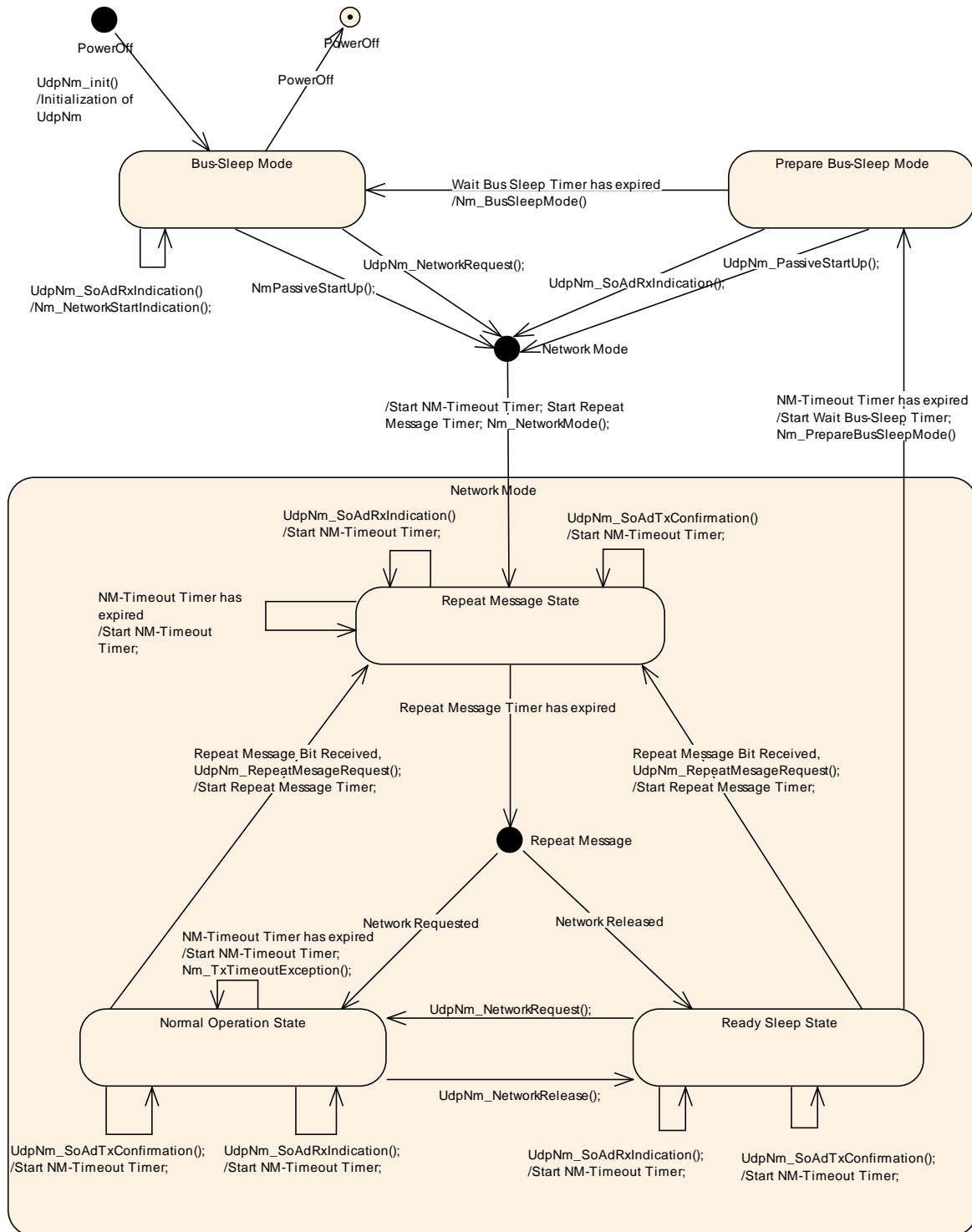

**Figure 6: State chart diagram.**

## 9 Sequence diagrams and Transition Tables

### 9.1 UdpNmTransmission

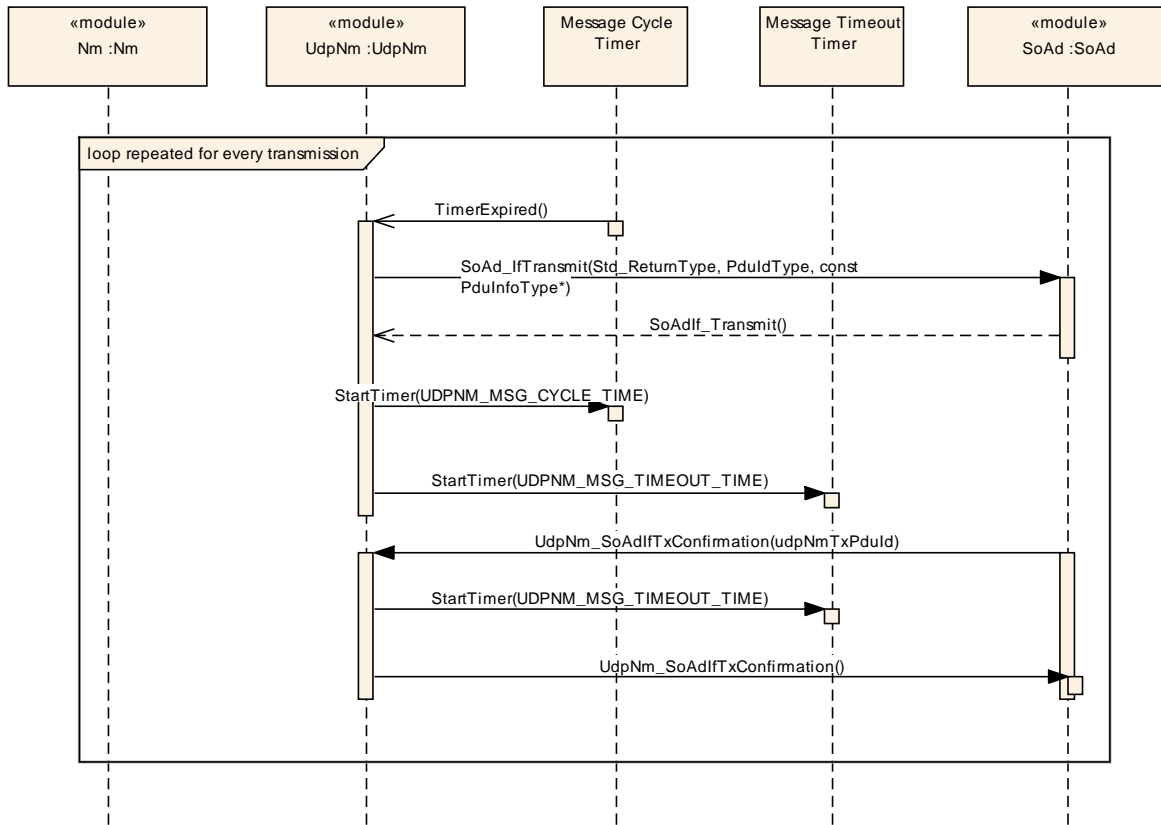
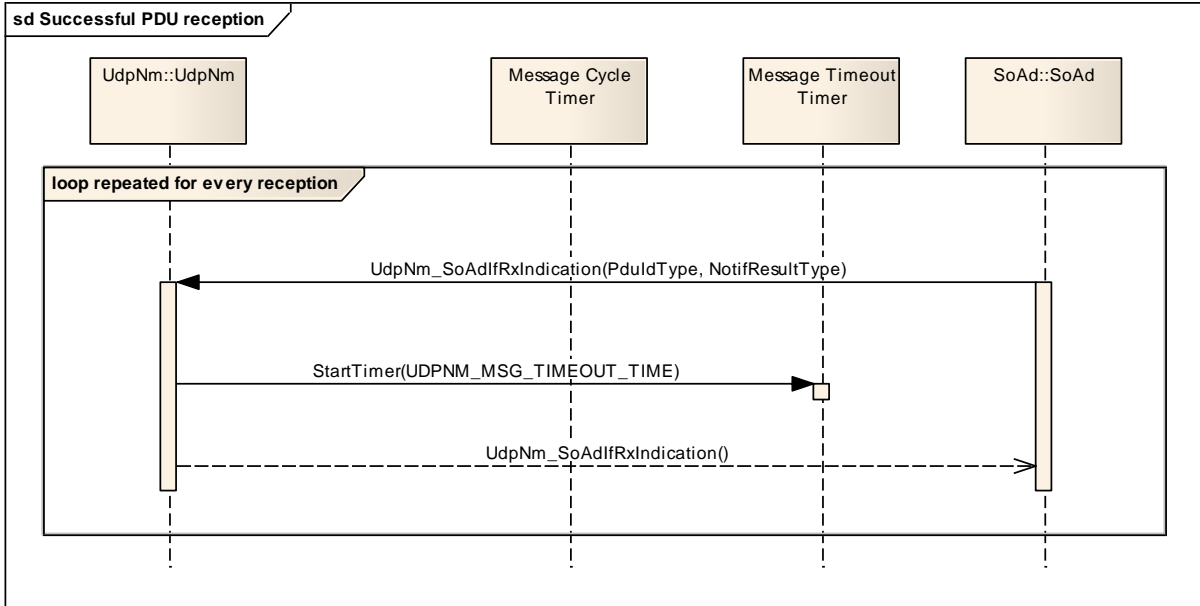

Figure 7: Sequence diagram – PDU transmission.

### 9.2 UdpNm Reception

Call direction	Action/Decision	Description
SoAd->UdpNm	UdpNm SoAdIfRxIndication()	



**Figure 8: Sequence diagram – PDU transmission.**

## 10 Configuration specification

In general, this chapter defines configuration parameters and their clustering into containers. In order to support the specification chapter 10.1 describes fundamentals. It also specifies a template (table) to be use for the parameter specification. Chapter 10.1 is intended to remain in the specification document to ensure comprehensiveness.

Chapter 10.2 specifies the structure (containers) and the parameters of module UdpNm.

Chapter 10.3 specifies published information of module UdpNm.

### 10.1 How to read this chapter

For details refer to the chapter 10.1 “Introduction to configuration specification” in *SWS\_BSWGeneral*.

### 10.2 Containers and configuration parameters

The configuration parameters as defined in this chapter are used to create a data model for an AUTOSAR tool chain. The realization in the code is implementation specific.

The configuration parameters as defined in this chapter are used to create a data model for an AUTOSAR tool chain. The realization in the code is implementation specific.

The configuration parameters are divided into parameters used to enable features, parameters affecting all instances of the UdpNm and parameters affecting the respective instances of the UdpNm.

[SWS\_UdpNm\_00026] [ All configuration items shall be located outside the kernel of the module. ] ()

[SWS\_UdpNm\_00201] [ The Global Scope specifies configuration parameter that shall be defined in the module’s configuration header file `UdpNm_Cfg.h`. ] ()

[SWS\_UdpNm\_00202] [ The container `UdpNm_ChannelConfig` specifies configuration parameter that shall be located in a data structure of type `UdpNm_ConfigType`. ] ()

[SWS\_UdpNm\_00203] [ Runtime configurable parameters listed in container `UdpNm_ChannelConfig` shall be configurable for each NM-cluster separately. ] ()

### 10.2.1 Variants

Variant 1: All configuration parameters shall be configurable at pre-compile time.  
Use case: Source code optimization.

Variant 2: All configuration parameters of the container UdpNm\_GlobalConfig related to enable or disable an optional feature shall be configurable at pre-compile time; the remaining configuration parameters shall be configurable at link time.

Use case: Object code.

Variant 3: The parameters contained in UdpNm\_ChannelConfig are configurable at post-build time. The parameters contained in UdpNm\_GlobalConfig are configurable at pre-compile time

Use case: ECU configuration can be flashed (L) and selected during initialization phase (M).

Note:

The possibility to select a configuration (post-build time type L) is explicitly mentioned for Variant 3 only, but from a technical perspective it is also possible to provide this configuration variant for variant 1 and 2.

### 10.2.2 UdpNm

<b>Module Name</b>	UdpNm
<b>Module Description</b>	--
<b>Post-Build Variant Support</b>	false

<b>Included Containers</b>		
<b>Container Name</b>	<b>Multiplicity</b>	<b>Scope / Dependency</b>
UdpNmGlobalConfig	1	This container contains all global configuration parameters of UDP NM configured from the CanTrcv Module perspective.

### 10.2.3 UdpNmGlobalConfig

<b>SWS Item</b>	<b>ECUC_UdpNm_00001 :</b>		
<b>Container Name</b>	UdpNmGlobalConfig		
<b>Description</b>	This container contains all global configuration parameters of UDP NM configured from the CanTrcv Module perspective.		
<b>Configuration Parameters</b>			

<b>SWS Item</b>	<b>ECUC_UdpNm_00006 :</b>		
<b>Name</b>	UdpNmBusSynchronizationEnabled		
<b>Description</b>	Pre-processor switch for enabling bus synchronization support. This feature is required for gateway nodes only. It must not be defined if UDPNM_PASSIVE_MODE_ENABLED is defined. This parameter shall be derived from NM_BUS_SYNCHRONIZATION_ENABLED.		
<b>Multiplicity</b>	1		
<b>Type</b>	EcucBooleanParamDef		
<b>Default value</b>	--		
<b>Post-Build Variant Value</b>	false		
<b>Value Configuration Class</b>	<b>Pre-compile time</b>	X	All Variants
	<b>Link time</b>	--	
	<b>Post-build time</b>	--	
<b>Scope / Dependency</b>	scope: local		

<b>SWS Item</b>	<b>ECUC_UdpNm_00077 :</b>		
<b>Name</b>	UdpNmCarWakeUpFilterEnabled		
<b>Description</b>	If CWU filtering is supported, only the CWU bit within the NM PDU with source node identifier UdpNmCarWakeUpFilterNodeId is considered as CWU request. FALSE - CWU filtering is not supported TRUE - CWU filtering is supported.		
<b>Multiplicity</b>	0..1		
<b>Type</b>	EcucBooleanParamDef		
<b>Default value</b>	--		
<b>Post-Build Variant Value</b>	false		
<b>Value Configuration Class</b>	<b>Pre-compile time</b>	X	All Variants
	<b>Link time</b>	--	
	<b>Post-build time</b>	--	
<b>Scope / Dependency</b>	scope: local		

<b>SWS Item</b>	<b>ECUC_UdpNm_00078 :</b>		
<b>Name</b>	UdpNmCarWakeUpFilterNodeId		
<b>Description</b>	Source node identifier for CWU filtering. If CWU filtering is supported, only the CWU bit within the NM PDU with source node identifier UdpNmCarWakeUpFilterNodeId is considered as CWU request.		
<b>Multiplicity</b>	0..1		
<b>Type</b>	EcucIntegerParamDef		
<b>Range</b>	0 .. 255		
<b>Default value</b>	--		
<b>Post-Build Variant Value</b>	false		
<b>Value Configuration Class</b>	<b>Pre-compile time</b>	X	All Variants
	<b>Link time</b>	--	
	<b>Post-build time</b>	--	

<b>Scope / Dependency</b>	scope: local
---------------------------	--------------

<b>SWS Item</b>	<b>ECUC_UdpNm_00076 :</b>		
<b>Name</b>	UdpNmCarWakeUpRxEnabled		
<b>Description</b>	Enables or disables support of CarWakeUp bit evaluation in received NM PDUs. FALSE - CarWakeUp not supported. TRUE - CarWakeUp supported.		
<b>Multiplicity</b>	1		
<b>Type</b>	EcucBooleanParamDef		
<b>Default value</b>	false		
<b>Post-Build Variant Value</b>	false		
<b>Value Configuration Class</b>	<b>Pre-compile time</b>	X	All Variants
	<b>Link time</b>	--	
	<b>Post-build time</b>	--	
<b>Scope / Dependency</b>	scope: local		

<b>SWS Item</b>	<b>ECUC_UdpNm_00013 :</b>		
<b>Name</b>	UdpNmComControlEnabled		
<b>Description</b>	Pre-processor switch for enabling the Communication Control support. This parameter shall be derived from NM_COM_CONTROL_ENABLED.		
<b>Multiplicity</b>	1		
<b>Type</b>	EcucBooleanParamDef		
<b>Default value</b>	--		
<b>Post-Build Variant Value</b>	false		
<b>Value Configuration Class</b>	<b>Pre-compile time</b>	X	All Variants
	<b>Link time</b>	--	
	<b>Post-build time</b>	--	
<b>Scope / Dependency</b>	scope: local		

<b>SWS Item</b>	<b>ECUC_UdpNm_00055 :</b>		
<b>Name</b>	UdpNmComUserDataSupport		
<b>Description</b>	Enable/disable the user data support.		
<b>Multiplicity</b>	1		
<b>Type</b>	EcucBooleanParamDef		
<b>Default value</b>	--		
<b>Post-Build Variant Value</b>	false		
<b>Value Configuration Class</b>	<b>Pre-compile time</b>	X	All Variants
	<b>Link time</b>	--	
	<b>Post-build time</b>	--	
<b>Scope / Dependency</b>	scope: local		

<b>SWS Item</b>	<b>ECUC_UdpNm_00040 :</b>		
<b>Name</b>	UdpNmCoordinatorEnabled		
<b>Description</b>	Enable/disable the NM Coordination algorithm to being able to initiate the synchronization algorithm. TRUE: Option is enabled FALSE: The parameter shall be FALSE by default and shall only be allowed to be TRUE if the parameter UDPNM_REMOTE_SLEEP_IND_ENABLED is TRUE.		
<b>Multiplicity</b>	1		
<b>Type</b>	EcucBooleanParamDef		
<b>Default value</b>	--		
<b>Post-Build Variant Value</b>	false		
<b>Value Configuration Class</b>	<b>Pre-compile time</b>	X	All Variants
	<b>Link time</b>	--	
	<b>Post-build time</b>	--	



<b>Scope / Dependency</b>	scope: local
---------------------------	--------------

<b>SWS Item</b>	<b>ECUC_UdpNm_00041 :</b>		
<b>Name</b>	UdpNmCoordinatorId		
<b>Description</b>	Set the NM coordination ID for this gateway. 0x00: passive coordinator only 0x01 - 0x03: coordinator priority Only valid, if UDPNM_COORDINATOR_ENABLED is TRUE.		
<b>Multiplicity</b>	1		
<b>Type</b>	EcucIntegerParamDef		
<b>Range</b>	0 .. 3		
<b>Default value</b>	--		
<b>Post-Build Variant Value</b>	false		
<b>Value Configuration Class</b>	<b>Pre-compile time</b>	X	All Variants
	<b>Link time</b>	--	
	<b>Post-build time</b>	--	
<b>Scope / Dependency</b>	scope: local		

<b>SWS Item</b>	<b>ECUC_UdpNm_00059 :</b>		
<b>Name</b>	UdpNmCoordinatorSyncSupport		
<b>Description</b>	Enables/disables the coordinator synchronization support.		
<b>Multiplicity</b>	1		
<b>Type</b>	EcucBooleanParamDef		
<b>Default value</b>	--		
<b>Post-Build Variant Value</b>	false		
<b>Value Configuration Class</b>	<b>Pre-compile time</b>	X	All Variants
	<b>Link time</b>	--	
	<b>Post-build time</b>	--	
<b>Scope / Dependency</b>	scope: local dependency: UdpNmCoordinatorSyncSupport has to be set to FALSE if UdpNmPassiveModeEnabled is set to TRUE.		

<b>SWS Item</b>	<b>ECUC_UdpNm_00002 :</b>		
<b>Name</b>	UdpNmDevErrorDetect		
<b>Description</b>	Switches the Default Error Tracer (Det) detection and notification ON or OFF.  <ul style="list-style-type: none"> <li>• true: enabled (ON).</li> <li>• false: disabled (OFF).</li> </ul>		
<b>Multiplicity</b>	1		
<b>Type</b>	EcucBooleanParamDef		
<b>Default value</b>	--		
<b>Post-Build Variant Value</b>	false		
<b>Value Configuration Class</b>	<b>Pre-compile time</b>	X	All Variants
	<b>Link time</b>	--	
	<b>Post-build time</b>	--	

<b>Scope / Dependency</b>	scope: local
---------------------------	--------------

<b>SWS Item</b>	<b>ECUC_UdpNm_00009 :</b>		
<b>Name</b>	UdpNmImmediateRestartEnabled		
<b>Description</b>	Pre-processor switch for enabling the asynchronous transmission of a NM PACKET upon bus-communication request in Prepare-Bus-Sleep mode. Must not be defined if UDPNM_PASSIVE_MODE_ENABLED is defined.		
<b>Multiplicity</b>	1		
<b>Type</b>	EcucBooleanParamDef		
<b>Default value</b>	--		
<b>Post-Build Variant Value</b>	false		
<b>Value Configuration Class</b>	<b>Pre-compile time</b>	X	All Variants
	<b>Link time</b>	--	
	<b>Post-build time</b>	--	
<b>Scope / Dependency</b>	scope: local		

<b>SWS Item</b>	<b>ECUC_UdpNm_00007 :</b>		
<b>Name</b>	UdpNmNodeDetectionEnabled		
<b>Description</b>	Pre-processor switch for enabling the node detection support. This parameter shall be derived from NM_NODE_DETECTION_ENABLED. This parameter shall only be enabled if UDPNM_NODE_ID_ENABLED is defined. If(UdpNmPduCbvPosition != UDPNM_PDU_OFF) then Equal(NmNodeDetectionEnabled) else Equal(False).		
<b>Multiplicity</b>	1		
<b>Type</b>	EcucBooleanParamDef		
<b>Default value</b>	--		
<b>Post-Build Variant Value</b>	false		
<b>Value Configuration Class</b>	<b>Pre-compile time</b>	X	All Variants
	<b>Link time</b>	--	
	<b>Post-build time</b>	--	
<b>Scope / Dependency</b>	scope: local dependency: Not available if UDPNM_PASSIVE_MODE_ENABLED		

<b>SWS Item</b>	<b>ECUC_UdpNm_00008 :</b>		
<b>Name</b>	UdpNmNodeIdEnabled		
<b>Description</b>	Pre-processor switch for enabling the source node identifier. This parameter shall be derived from NM_NODE_ID_ENABLED.		
<b>Multiplicity</b>	1		
<b>Type</b>	EcucBooleanParamDef		
<b>Default value</b>	--		
<b>Post-Build Variant Value</b>	false		
<b>Value Configuration Class</b>	<b>Pre-compile time</b>	X	All Variants
	<b>Link time</b>	--	
	<b>Post-build time</b>	--	

<b>Scope / Dependency</b>	scope: local
---------------------------	--------------

<b>SWS Item</b>	<b>ECUC_UdpNm_00014 :</b>		
<b>Name</b>	UdpNmNumberOfChannels		
<b>Description</b>	Number of NM channels allowed within one ECU.		
<b>Multiplicity</b>	1		
<b>Type</b>	EcucIntegerParamDef		
<b>Range</b>	1 .. 255		
<b>Default value</b>	--		
<b>Post-Build Variant Value</b>	false		
<b>Value Configuration Class</b>	<b>Pre-compile time</b>	X	All Variants
	<b>Link time</b>	--	
	<b>Post-build time</b>	--	
<b>Scope / Dependency</b>	scope: local		

<b>SWS Item</b>	<b>ECUC_UdpNm_00010 :</b>		
<b>Name</b>	UdpNmPassiveModeEnabled		
<b>Description</b>	Pre-processor switch for enabling support of the Passive Mode. This parameter shall be derived from NM_PASSIVE_MODE_ENABLED.		
<b>Multiplicity</b>	1		
<b>Type</b>	EcucBooleanParamDef		
<b>Default value</b>	--		
<b>Post-Build Variant Value</b>	false		
<b>Value Configuration Class</b>	<b>Pre-compile time</b>	X	All Variants
	<b>Link time</b>	--	
	<b>Post-build time</b>	--	
<b>Scope / Dependency</b>	scope: local		

<b>SWS Item</b>	<b>ECUC_UdpNm_00011 :</b>		
<b>Name</b>	UdpNmPduRxIndicationEnabled		
<b>Description</b>	Pre-processor switch for enabling the PDU Rx Indication. This parameter shall be derived from NM_PDU_RX_INDICATION_ENABLED.		
<b>Multiplicity</b>	1		
<b>Type</b>	EcucBooleanParamDef		
<b>Default value</b>	--		
<b>Post-Build Variant Value</b>	false		
<b>Value Configuration Class</b>	<b>Pre-compile time</b>	X	All Variants
	<b>Link time</b>	--	
	<b>Post-build time</b>	--	
<b>Scope / Dependency</b>	scope: local		

<b>SWS Item</b>	<b>ECUC_UdpNm_00066 :</b>		
<b>Name</b>	UdpNmPnEiraCalcEnabled		
<b>Description</b>	Specifies if UdpNm calculates the PN request information for internal and external requests. (EIRA) true: PN request are calculated false: PN request are not calculated		
<b>Multiplicity</b>	0..1		
<b>Type</b>	EcucBooleanParamDef		
<b>Default value</b>	false		
<b>Post-Build Variant Value</b>	false		
<b>Multiplicity Configuration Class</b>	<b>Pre-compile time</b>	X	VARIANT-PRE-COMPILE
	<b>Link time</b>	X	VARIANT-LINK-TIME
	<b>Post-build time</b>	--	

<b>Value Configuration Class</b>	<b>Pre-compile time</b>	X	VARIANT-PRE-COMPILE
	<b>Link time</b>	X	VARIANT-LINK-TIME
	<b>Post-build time</b>	--	
<b>Scope / Dependency</b>	scope: local dependency: only available if UdpNmPnEnabled == true for at least one UdpNm Channel		

<b>SWS Item</b>	<b>ECUC_UdpNm_00065 :</b>		
<b>Name</b>	UdpNmPnResetTime		
<b>Description</b>	Specifies the runtime of the reset timer in seconds. This reset time is valid for the reset of PN requests in the EIRA and in the ERA. The value shall be the same for every channel. Thus it is a global config parameter.		
<b>Multiplicity</b>	0..1		
<b>Type</b>	EcucFloatParamDef		
<b>Range</b>	0.001 .. 65.535		
<b>Default value</b>	--		
<b>Post-Build Variant Multiplicity</b>	false		
<b>Post-Build Variant Value</b>	false		
<b>Value Configuration Class</b>	<b>Pre-compile time</b>	X	VARIANT-PRE-COMPILE
	<b>Link time</b>	X	VARIANT-LINK-TIME
	<b>Post-build time</b>	--	
<b>Scope / Dependency</b>	scope: local dependency: only available if UdpNmPnEnabled == true for at least one UdpNm Channel.		

<b>SWS Item</b>	<b>ECUC_UdpNm_00005 :</b>		
<b>Name</b>	UdpNmRemoteSleepIndEnabled		
<b>Description</b>	Pre-processor switch for enabling remote sleep indication support. This feature is required for gateway nodes only. It must not be defined if UDPNM_PASSIVE_MODE_ENABLED is defined. This parameter shall be derived from NM_REMOTE_SLEEP_IND_ENABLED.		
<b>Multiplicity</b>	1		
<b>Type</b>	EcucBooleanParamDef		
<b>Default value</b>	--		
<b>Post-Build Variant Value</b>	false		
<b>Value Configuration Class</b>	<b>Pre-compile time</b>	X	All Variants
	<b>Link time</b>	--	
	<b>Post-build time</b>	--	
<b>Scope / Dependency</b>	scope: local		

<b>SWS Item</b>	<b>ECUC_UdpNm_00015 :</b>		
<b>Name</b>	UdpNmRepeatMsgIndEnabled		
<b>Description</b>	Enable/disable the notification that a RepeatMessageRequest bit has been received. This parameter shall be derived from NM_REPEAT_MSG_IND_ENABLED.		
<b>Multiplicity</b>	1		
<b>Type</b>	EcucBooleanParamDef		
<b>Default value</b>	--		
<b>Post-Build Variant Value</b>	false		
<b>Value Configuration Class</b>	<b>Pre-compile time</b>	X	All Variants
	<b>Link time</b>	--	

	<b>Post-build time</b>	--	
<b>Scope / Dependency</b>	scope: local		

<b>SWS Item</b>	<b>ECUC_UdpNm_00012 :</b>		
<b>Name</b>	UdpNmStateChangeIndEnabled		
<b>Description</b>	Pre-processor switch for enabling the UDP NM state change notification. This parameter shall be derived from NM_STATE_CHANGE_IND_ENABLED.		
<b>Multiplicity</b>	1		
<b>Type</b>	EcucBooleanParamDef		
<b>Default value</b>	--		
<b>Post-Build Variant Value</b>	false		
<b>Value Configuration Class</b>	<b>Pre-compile time</b>	X	All Variants
	<b>Link time</b>	--	
	<b>Post-build time</b>	--	
<b>Scope / Dependency</b>	scope: local		

<b>SWS Item</b>	<b>ECUC_UdpNm_00004 :</b>		
<b>Name</b>	UdpNmUserDataEnabled		
<b>Description</b>	Pre-processor switch for enabling user data support. This parameter shall be derived from NM_USER_DATA_ENABLED.		
<b>Multiplicity</b>	1		
<b>Type</b>	EcucBooleanParamDef		
<b>Default value</b>	--		
<b>Post-Build Variant Value</b>	false		
<b>Value Configuration Class</b>	<b>Pre-compile time</b>	X	All Variants
	<b>Link time</b>	--	
	<b>Post-build time</b>	--	
<b>Scope / Dependency</b>	scope: local		

<b>SWS Item</b>	<b>ECUC_UdpNm_00003 :</b>		
<b>Name</b>	UdpNmVersionInfoApi		
<b>Description</b>	Pre-processor switch for enabling version info API support.		
<b>Multiplicity</b>	1		
<b>Type</b>	EcucBooleanParamDef		
<b>Default value</b>	--		
<b>Post-Build Variant Value</b>	false		
<b>Value Configuration Class</b>	<b>Pre-compile time</b>	X	All Variants
	<b>Link time</b>	--	
	<b>Post-build time</b>	--	
<b>Scope / Dependency</b>	scope: local		

<b>SWS Item</b>	<b>ECUC_UdpNm_00062 :</b>		
<b>Name</b>	UdpNmPnEiraRxNSduRef		
<b>Description</b>	Reference to a Pdu in the COM-Stack. Only one SduRef is required for UdpNm because the EIRA is the aggregation over all Ethernet Channels.		
<b>Multiplicity</b>	0..1		
<b>Type</b>	Reference to [ Pdu ]		
<b>Post-Build Variant Multiplicity</b>	false		
<b>Post-Build Variant Value</b>	false		
<b>Multiplicity Configuration Class</b>	<b>Pre-compile time</b>	X	VARIANT-PRE-COMPILE
	<b>Link time</b>	X	VARIANT-LINK-TIME
	<b>Post-build time</b>	--	
<b>Value Configuration Class</b>	<b>Pre-compile time</b>	X	VARIANT-PRE-COMPILE
	<b>Link time</b>	X	VARIANT-LINK-TIME

	<b>Post-build time</b>	--	
<b>Scope / Dependency</b>	scope: local dependency: only available if UdpNmPnEnabled == true for at least one UdpNm Channel		

<b>Included Containers</b>		
<b>Container Name</b>	<b>Multiplicity</b>	<b>Scope / Dependency</b>
UdpNmChannelConfig	1..*	This container contains the channel-specific configuration parameters of the UdpNm.
UdpNmDemEventParameterReferences	0..1	Container for the references to DemEventParameter elements which shall be invoked using the API Dem_ReportErrorStatus API in case the corresponding error occurs. The EventId is taken from the referenced DemEventParameter's DemEventId value. The standardized errors are provided in the container and can be extended by vendor specific error references.
UdpNmPnInfo	0..1	PN information configuration

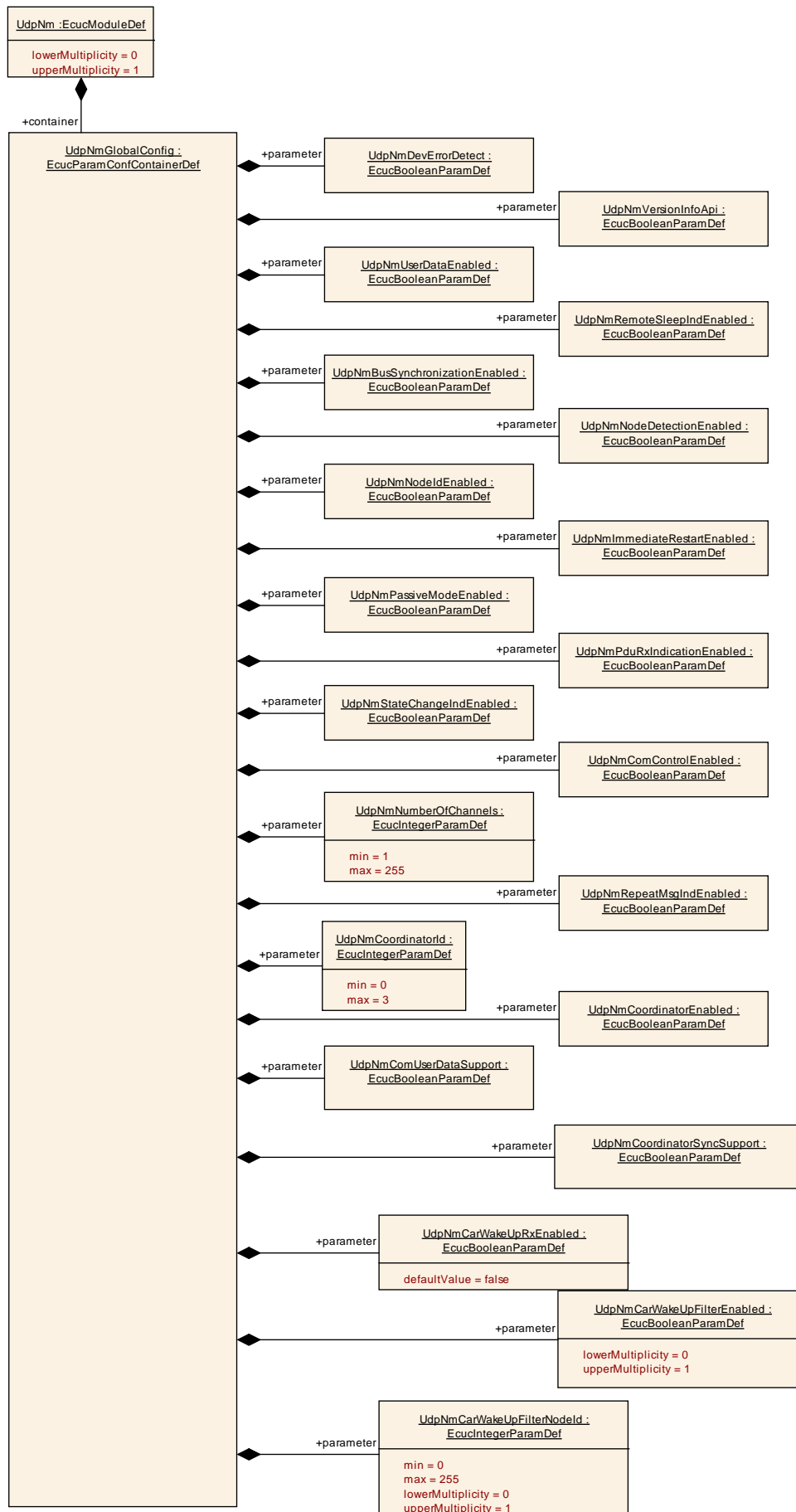

Figure 9: Diagram: UdpNmGlobalConfig

### 10.2.4 UdpNmChannelConfig

<b>SWS Item</b>	<b>ECUC_UdpNm_00017 :</b>
<b>Container Name</b>	UdpNmChannelConfig
<b>Description</b>	This container contains the channel-specific configuration parameters of the UdpNm.
<b>Configuration Parameters</b>	

<b>SWS Item</b>	<b>ECUC_UdpNm_00074 :</b>		
<b>Name</b>	UdpNmActiveWakeupBitEnabled		
<b>Description</b>	Enables/Disables the handling of the Active Wakeup Bit in the UdpNm module.		
<b>Multiplicity</b>	0..1		
<b>Type</b>	EcucBooleanParamDef		
<b>Default value</b>	false		
<b>Post-Build Variant Multiplicity</b>	false		
<b>Post-Build Variant Value</b>	false		
<b>Multiplicity Configuration Class</b>	<b>Pre-compile time</b>	X	VARIANT-PRE-COMPILE
	<b>Link time</b>	X	VARIANT-LINK-TIME
	<b>Post-build time</b>	--	
<b>Value Configuration Class</b>	<b>Pre-compile time</b>	X	VARIANT-PRE-COMPILE
	<b>Link time</b>	X	VARIANT-LINK-TIME
	<b>Post-build time</b>	--	
<b>Scope / Dependency</b>	scope: local dependency: This parameter is only valid if UdpNmPassiveModeEnabled is False.		

<b>SWS Item</b>	<b>ECUC_UdpNm_00075 :</b>		
<b>Name</b>	UdpNmImmediateNmTransmissions		
<b>Description</b>	Defines the number of immediate NM PDUs which shall be transmitted. If the value is zero no immediate NM PDUs are transmitted.		
<b>Multiplicity</b>	1		
<b>Type</b>	EcucIntegerParamDef		
<b>Range</b>	0 .. 255		
<b>Default value</b>	--		
<b>Post-Build Variant Value</b>	false		
<b>Value Configuration Class</b>	<b>Pre-compile time</b>	X	VARIANT-PRE-COMPILE
	<b>Link time</b>	X	VARIANT-LINK-TIME
	<b>Post-build time</b>	--	



<b>Scope / Dependency</b>	scope: local dependency: If UdpNmImmediateRestartEnabled = true then UdpNmImmediateNmTransmissions = 0
---------------------------	--

<b>SWS Item</b>	<b>ECUC_UdpNm_00032 :</b>		
<b>Name</b>	UdpNmMainFunctionPeriod		
<b>Description</b>	Call cycle of UdpNm_MainFunction_x for the respective instance in [s].		
<b>Multiplicity</b>	1		
<b>Type</b>	EcucFloatParamDef		
<b>Range</b>	0.001 .. 0.255		
<b>Default value</b>	--		
<b>Post-Build Variant Value</b>	false		
<b>Value Configuration Class</b>	<b>Pre-compile time</b>	X	VARIANT-PRE-COMPILE
	<b>Link time</b>	X	VARIANT-LINK-TIME
	<b>Post-build time</b>	--	
<b>Scope / Dependency</b>	scope: local		

<b>SWS Item</b>	<b>ECUC_UdpNm_00029 :</b>		
<b>Name</b>	UdpNmMsgCycleOffset		
<b>Description</b>	Time offset in the periodic transmission node. It determines the start delay of the transmission. < UDPNM_MSG_CYCLE_TIME This parameter is only valid if UDPNM_PASSIVE_MODE_ENABLED is disabled.		
<b>Multiplicity</b>	1		
<b>Type</b>	EcucFloatParamDef		
<b>Range</b>	0 .. 65.535		
<b>Default value</b>	--		
<b>Post-Build Variant Value</b>	false		
<b>Value Configuration Class</b>	<b>Pre-compile time</b>	X	VARIANT-PRE-COMPILE
	<b>Link time</b>	X	VARIANT-LINK-TIME
	<b>Post-build time</b>	--	
<b>Scope / Dependency</b>	scope: local		

<b>SWS Item</b>	<b>ECUC_UdpNm_00028 :</b>		
<b>Name</b>	UdpNmMsgCycleTime		
<b>Description</b>	Period of a NM-message. It determines the periodic rate and is the basis for transmit scheduling. $NM\_TIMEOUT\_TIME = n * UDPNM\_MSG\_CYCLE\_TIME$ This parameter is only valid if UDPNM_PASSIVE_MODE_ENABLED is disabled.		
<b>Multiplicity</b>	1		
<b>Type</b>	EcucFloatParamDef		
<b>Range</b>	0.001 .. 65.535		
<b>Default value</b>	--		
<b>Post-Build Variant Value</b>	false		
<b>Value Configuration Class</b>	<b>Pre-compile time</b>	X	VARIANT-PRE-COMPILE
	<b>Link time</b>	X	VARIANT-LINK-TIME
	<b>Post-build time</b>	--	

<b>Scope / Dependency</b>	scope: local		
<b>SWS Item</b>	<b>ECUC_UdpNm_00030 :</b>		
<b>Name</b>	UdpNmMsgTimeoutTime		
<b>Description</b>	<p>Transmission Timeout of NM-message. If there is no transmission confirmation by the UDP Interface within this timeout, the UDPNM module shall give an error notification.</p> <p>This parameter is only valid if UDPNM_PASSIVE_MODE_ENABLED is disabled.</p> <p>UDPNM_MSG_TIMEOUT_TIME should be a multiple of UDPNM_MSG_CYCLE_TIME.</p>		
<b>Multiplicity</b>	1		
<b>Type</b>	EcucFloatParamDef		
<b>Range</b>	0.001 .. 65.535		
<b>Default value</b>	--		
<b>Post-Build Variant Value</b>	false		
<b>Value Configuration Class</b>	<b>Pre-compile time</b>	X	VARIANT-PRE-COMPILE
	<b>Link time</b>	X	VARIANT-LINK-TIME
	<b>Post-build time</b>	--	
<b>Scope / Dependency</b>	scope: local		

<b>SWS Item</b>	<b>ECUC_UdpNm_00031 :</b>		
<b>Name</b>	UdpNmNodeId		
<b>Description</b>	<p>Node identifier of local node.</p> <p>This parameter is only valid if UDPNM_PASSIVE_MODE_ENABLED is set to OFF and UDPNM_NODE_DETECTION_ENABLED is set to ON.</p>		
<b>Multiplicity</b>	1		
<b>Type</b>	EcucIntegerParamDef		
<b>Range</b>	0 .. 255		
<b>Default value</b>	--		
<b>Post-Build Variant Value</b>	false		
<b>Value Configuration Class</b>	<b>Pre-compile time</b>	X	VARIANT-PRE-COMPILE
	<b>Link time</b>	X	VARIANT-LINK-TIME
	<b>Post-build time</b>	--	
<b>Scope / Dependency</b>	scope: local		

<b>SWS Item</b>	<b>ECUC_UdpNm_00026 :</b>		
<b>Name</b>	UdpNmPduCbvPosition		
<b>Description</b>	<p>Defines the position of the control bit vector within the NM PACKET.</p> <p>The value of the parameter represents the location of the control bit vector in the NM PACKET (UDPNM_PDU_BYTE_0 means byte 0, UDPNM_PDU_BYTE_1 means byte 1, UDPNM_PDU_OFF means the control bit vector is not part of the NM PACKET)</p> <p>See also UDPNM_PDU_NID_POSITION            if (UDPNM_PDU_CBV_POSITION != UDPNM_PDU_OFF &amp;&amp;            UDPNM_PDU_NID_POSITION != UDPNM_PDU_OFF) then            UDPNM_PDU_CBV_POSITION != UDPNM_PDU_NID_POSITION            if (UDPNM_PDU_CBV_POSITION != UDPNM_PDU_OFF &amp;&amp;            UDPNM_PDU_NID_POSITION == UDPNM_PDU_OFF) then            UDPNM_PDU_CBV_POSITION = UDPNM_PDU_BYTE0</p>		
<b>Multiplicity</b>	1		
<b>Type</b>	EcucEnumerationParamDef		
<b>Range</b>	UDPNM_PDU_BYTE_0	--	
	UDPNM_PDU_BYTE_1	--	
	UDPNM_PDU_OFF	--	

<b>Post-Build Variant Value</b>	false		
<b>Value Configuration Class</b>	<b>Pre-compile time</b>	X	VARIANT-PRE-COMPILE
	<b>Link time</b>	X	VARIANT-LINK-TIME
	<b>Post-build time</b>	--	
<b>Scope Dependency</b>	scope: local		

<b>SWS Item</b>	<b>ECUC_UdpNm_00024 :</b>		
<b>Name</b>	UdpNmPduLength		
<b>Description</b>	Defines the length of the NM PACKET in bytes. Valid values are within the range $0 \leq \text{UDPNM\_PDU\_LENGTH} \leq 8$ .		
<b>Multiplicity</b>	1		
<b>Type</b>	EcucIntegerParamDef		
<b>Range</b>	0 .. 8		
<b>Default value</b>	--		
<b>Post-Build Variant Value</b>	false		
<b>Value Configuration Class</b>	<b>Pre-compile time</b>	X	VARIANT-PRE-COMPILE
	<b>Link time</b>	X	VARIANT-LINK-TIME
	<b>Post-build time</b>	--	
<b>Scope / Dependency</b>	scope: ECU		

<b>SWS Item</b>	<b>ECUC_UdpNm_00025 :</b>		
<b>Name</b>	UdpNmPduNidPosition		
<b>Description</b>	Defines the position of the source node identifier within the NM PACKET. ImplementationType: UdpNm_PduPositionType The value of the parameter represents the location of the source node identifier in the NM PACKET (UDPNM_PDU_BYTE_0 means byte 0, UDPNM_PDU_BYTE_1 means byte 1, UDPNM_PDU_OFF means source node identifier is not part of the NM PACKET) See also UDPNM_PDU_CBV_POSITION if (UDPNM_PDU_NID_POSITION != UDPNM_PDU_OFF && UDPNM_PDU_CBV_POSITION != UDPNM_PDU_OFF) then UDPNM_PDU_NID_POSITION != UDPNM_PDU_CBV_POSITION if (UDPNM_PDU_NID_POSITION != UDPNM_PDU_OFF && UDPNM_PDU_CBV_POSITION == UDPNM_PDU_OFF) then UDPNM_PDU_IND_POSITION = UDPNM_PDU_BYTE0		
<b>Multiplicity</b>	1		
<b>Type</b>	EcucEnumerationParamDef		
<b>Range</b>	UDPNM_PDU_BYTE_0	Byte 0 is used.	
	UDPNM_PDU_BYTE_1	Byte 1 is used.	
	UDPNM_PDU_OFF	Node Identification is not used.	
<b>Post-Build Variant Value</b>	false		
<b>Value Configuration Class</b>	<b>Pre-compile time</b>	X	VARIANT-PRE-COMPILE
	<b>Link time</b>	X	VARIANT-LINK-TIME
	<b>Post-build time</b>	--	

<b>Scope</b>	scope: local
<b>Dependency</b>	

<b>SWS Item</b>	<b>ECUC_UdpNm_00061 :</b>		
<b>Name</b>	UdpNmPnEnabled		
<b>Description</b>	Enables or disables support of partial networking. false: Partial networking Range not supported true: Partial networking supported		
<b>Multiplicity</b>	0..1		
<b>Type</b>	EcucBooleanParamDef		
<b>Default value</b>	false		
<b>Post-Build Multiplicity</b>	<b>Variant</b>	false	
<b>Post-Build Variant Value</b>	false		
<b>Multiplicity Configuration Class</b>	<b>Pre-compile time</b>	X	VARIANT-PRE-COMPILE
	<b>Link time</b>	X	VARIANT-LINK-TIME
	<b>Post-build time</b>	--	
<b>Value Configuration Class</b>	<b>Pre-compile time</b>	X	VARIANT-PRE-COMPILE
	<b>Link time</b>	X	VARIANT-LINK-TIME
	<b>Post-build time</b>	--	
<b>Scope / Dependency</b>	scope: local dependency: only available if UdpNmPnEnabled == true		

<b>SWS Item</b>	<b>ECUC_UdpNm_00060 :</b>		
<b>Name</b>	UdpNmPnEraCalcEnabled		
<b>Description</b>	Specifies if UdpNm calculates the PN request information for external requests. (ERA) false: PN request are not calculated true: PN request are calculated.		
<b>Multiplicity</b>	0..1		
<b>Type</b>	EcucBooleanParamDef		
<b>Default value</b>	false		
<b>Post-Build Multiplicity</b>	<b>Variant</b>	false	
<b>Post-Build Variant Value</b>	false		
<b>Multiplicity Configuration Class</b>	<b>Pre-compile time</b>	X	VARIANT-PRE-COMPILE
	<b>Link time</b>	X	VARIANT-LINK-TIME
	<b>Post-build time</b>	--	
<b>Value Configuration Class</b>	<b>Pre-compile time</b>	X	VARIANT-PRE-COMPILE
	<b>Link time</b>	X	VARIANT-LINK-TIME
	<b>Post-build time</b>	--	
<b>Scope / Dependency</b>	scope: local dependency: only available if UdpNmPnEnabled == true		

<b>SWS Item</b>	<b>ECUC_UdpNm_00063 :</b>		
<b>Name</b>	UdpNmPnHandleMultipleNetworkRequests		
<b>Description</b>	false: UdpNm_NetworkRequest is ignored in NO. true: UdpNm_NetworkRequest triggers a change from NO to RM.		
<b>Multiplicity</b>	0..1		
<b>Type</b>	EcucBooleanParamDef		
<b>Default value</b>	false		
<b>Post-Build Multiplicity</b>	<b>Variant</b>	false	
<b>Post-Build Variant Value</b>	false		
<b>Multiplicity Configuration Class</b>	<b>Pre-compile time</b>	X	VARIANT-PRE-COMPILE
	<b>Link time</b>	X	VARIANT-LINK-TIME
	<b>Post-build time</b>	--	

<b>Value Configuration Class</b>	<b>Pre-compile time</b>	X	VARIANT-PRE-COMPILE
	<b>Link time</b>	X	VARIANT-LINK-TIME
	<b>Post-build time</b>	--	
<b>Scope / Dependency</b>	scope: local dependency: only available if UdpNmPnEnabled == true		

<b>SWS Item</b>	<b>ECUC_UdpNm_00023 :</b>		
<b>Name</b>	UdpNmRemoteSleepIndTime		
<b>Description</b>	<p>Timeout for Remote Sleep Indication. It defines the time in [s] how long it shall take to recognize that all other nodes are ready to sleep. Typically it should be equal to: <math>n * \text{UDPNM\_MSG\_CYCLE\_TIME}</math>, where <math>n</math> denotes the number of NM packets that are normally sent before Remote Sleep Indication is detected. The value of <math>n</math> decremented by one determines the amount of lost NM packets that can be tolerated by the Remote Sleep Indication procedure.</p>		
<b>Multiplicity</b>	1		
<b>Type</b>	EcucFloatParamDef		
<b>Range</b>	0.001 .. 65.535		
<b>Default value</b>	--		
<b>Post-Build Variant Value</b>	false		
<b>Value Configuration Class</b>	<b>Pre-compile time</b>	X	VARIANT-PRE-COMPILE
	<b>Link time</b>	X	VARIANT-LINK-TIME
	<b>Post-build time</b>	--	
<b>Scope / Dependency</b>	scope: local		

<b>SWS Item</b>	<b>ECUC_UdpNm_00022 :</b>		
<b>Name</b>	UdpNmRepeatMessageTime		
<b>Description</b>	<p>Timeout for Repeat Message State. It defines the time in [s] how long the NM shall stay in the Repeat Message State. Typically it should be equal to: <math>n * \text{UDPNM\_MSG\_CYCLE\_TIME}</math>, where <math>n</math> denotes the number of NM packets that are normally sent in the Repeat Message State. The value of <math>n</math> decremented by one determines the amount of lost NM packets that can be tolerated by the node detection procedure. The value 0 denotes that no Repeat Message State is configured. It means that Repeat Message State is transient what implicates that it is left immediately after entrance and in result no start-up stability is guaranteed and no node detection procedure is possible.</p>		
<b>Multiplicity</b>	1		
<b>Type</b>	EcucFloatParamDef		
<b>Range</b>	0 .. 65.535		
<b>Default value</b>	--		
<b>Post-Build Variant Value</b>	false		
<b>Value Configuration Class</b>	<b>Pre-compile time</b>	X	VARIANT-PRE-COMPILE
	<b>Link time</b>	X	VARIANT-LINK-TIME
	<b>Post-build time</b>	--	

<b>Scope / Dependency</b>	scope: local
---------------------------	--------------

<b>SWS Item</b>	<b>ECUC_UdpNm_00020 :</b>		
<b>Name</b>	UdpNmTimeoutTime		
<b>Description</b>	Network Timeout for NM packets. It denotes the time in [s] how long the NM shall stay in the Network Mode before transition into Prepare Bus-Sleep Mode shall take place. It shall be equal for all nodes in the cluster. It shall be greater than UDPNM_MSG_CYCLE_TIME. Typically, it should be equal to: $x * \text{UDPNM\_MSG\_CYCLE\_TIME}$ , where $n$ denotes the number of NM PACKET cycle times in the Ready Sleep State before transition into the Bus-Sleep Mode is initiated. The value of $n$ decremented by one determines the amount of lost NM packets that can be tolerated by the coordination algorithm.		
<b>Multiplicity</b>	1		
<b>Type</b>	EcucFloatParamDef		
<b>Range</b>	0.002 .. 65.535		
<b>Default value</b>	--		
<b>Post-Build Variant Value</b>	false		
<b>Value Configuration Class</b>	<b>Pre-compile time</b>	X	VARIANT-PRE-COMPILE
	<b>Link time</b>	X	VARIANT-LINK-TIME
	<b>Post-build time</b>	--	
<b>Scope / Dependency</b>	scope: local		

<b>SWS Item</b>	<b>ECUC_UdpNm_00021 :</b>		
<b>Name</b>	UdpNmWaitBusSleepTime		
<b>Description</b>	Timeout for bus calm down phase. It denotes the time in [s] how long the NM shall stay in the Prepare Bus-Sleep Mode before transition into Bus-Sleep Mode shall take place. It shall be equal for all nodes in the cluster. It shall be long enough to empty all Tx-buffer empty.		
<b>Multiplicity</b>	1		
<b>Type</b>	EcucFloatParamDef		
<b>Range</b>	0.001 .. 65.535		
<b>Default value</b>	--		
<b>Post-Build Variant Value</b>	false		
<b>Value Configuration Class</b>	<b>Pre-compile time</b>	X	VARIANT-PRE-COMPILE
	<b>Link time</b>	X	VARIANT-LINK-TIME
	<b>Post-build time</b>	--	
<b>Scope / Dependency</b>	scope: local		

<b>SWS Item</b>	<b>ECUC_UdpNm_00018 :</b>		
<b>Name</b>	UdpNmComMNetworkHandleRef		
<b>Description</b>	This reference points to the unique channel defined by the ComMChannel and provides access to the unique channel index value in ComMChannelId.		
<b>Multiplicity</b>	1		
<b>Type</b>	Symbolic name reference to [ ComMChannel ]		
<b>Post-Build Variant Value</b>	false		
<b>Value Configuration Class</b>	<b>Pre-compile time</b>	X	VARIANT-PRE-COMPILE
	<b>Link time</b>	X	VARIANT-LINK-TIME
	<b>Post-build time</b>	--	

<b>Scope / Dependency</b>	scope: ECU		
<b>SWS Item</b>	<b>ECUC_UdpNm_00073 :</b>		
<b>Name</b>	UdpNmPnEraRxNSduRef		
<b>Description</b>	Reference to a Pdu in the COM-Stack. The SduRef is required for every UdpNm Channel, because ERA is reported per channel.		
<b>Multiplicity</b>	0..1		
<b>Type</b>	Reference to [ Pdu ]		
<b>Post-Build Multiplicity</b>	<b>Variant</b>	false	
<b>Post-Build Variant Value</b>	false		
<b>Multiplicity Configuration Class</b>	<b>Pre-compile time</b>	X	VARIANT-PRE-COMPILE
	<b>Link time</b>	X	VARIANT-LINK-TIME
	<b>Post-build time</b>	--	
<b>Value Configuration Class</b>	<b>Pre-compile time</b>	X	VARIANT-PRE-COMPILE
	<b>Link time</b>	X	VARIANT-LINK-TIME
	<b>Post-build time</b>	--	
<b>Scope / Dependency</b>	scope: local dependency: only available if UdpNmPnEnabled == true		

<b>Included Containers</b>		
<b>Container Name</b>	<b>Multiplicity</b>	<b>Scope / Dependency</b>
UdpNmRxPdu	1..*	This container describes the UdpNm RX PDU's.
UdpNmTxPdu	0..1	This container describes the UdpNm TX PDU's.
UdpNmUserDataTxPdu	0..1	This optional container is used to configure the UserNm PDU. This container is only available if UdpNmComUserDataSupport is enabled.

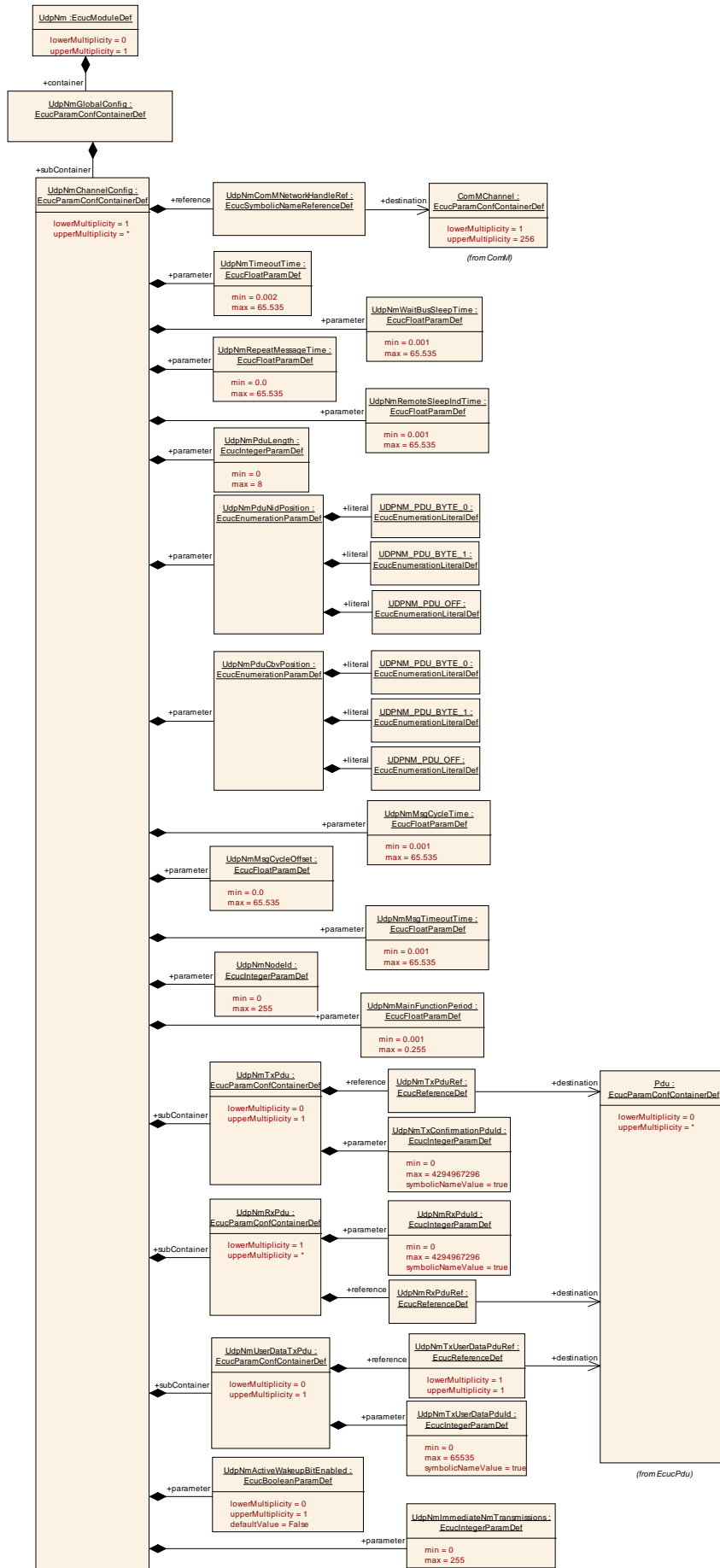



**Figure 10: UdpNmChannelConfig**

**10.2.5 UdpNmRxPdu**

<b>SWS Item</b>	<b>ECUC_UdpNm_00038 :</b>		
<b>Container Name</b>	UdpNmRxPdu		
<b>Description</b>	This container describes the UdpNm RX PDU's.		
<b>Configuration Parameters</b>			
<b>SWS Item</b>	<b>ECUC_UdpNm_00043 :</b>		
<b>Name</b>	UdpNmRxPduId		
<b>Description</b>	ID of the RxPdu that will be used by a RxIndication of the lower layer.		
<b>Multiplicity</b>	1		
<b>Type</b>	EcucIntegerParamDef (Symbolic Name generated for this parameter)		
<b>Range</b>	0 .. 4294967296		
<b>Default value</b>	--		
<b>Post-Build Variant Value</b>	false		
<b>Value Configuration Class</b>	<b>Pre-compile time</b>	X	All Variants
	<b>Link time</b>	--	
	<b>Post-build time</b>	--	
<b>Scope / Dependency</b>	scope: local		
<b>SWS Item</b>	<b>ECUC_UdpNm_00039 :</b>		
<b>Name</b>	UdpNmRxPduRef		
<b>Description</b>	The reference to a PDU in the global PDU structure described in the AUTOSAR ECU Configuration Specification. This reference will be used by the UdpNm module to derive the PDU Id.		
<b>Multiplicity</b>	1		
<b>Type</b>	Reference to [ Pdu ]		
<b>Post-Build Variant Value</b>	false		
<b>Value Configuration Class</b>	<b>Pre-compile time</b>	X	VARIANT-PRE-COMPILE
	<b>Link time</b>	X	VARIANT-LINK-TIME
	<b>Post-build time</b>	--	
<b>Scope / Dependency</b>	scope: local		
<b>No Included Containers</b>			

### 10.2.6 UdpNmTxPdu

<b>SWS Item</b>	<b>ECUC_UdpNm_00036 :</b>
<b>Container Name</b>	UdpNmTxPdu
<b>Description</b>	This container describes the UdpNm TX PDU's.
<b>Configuration Parameters</b>	

<b>SWS Item</b>	<b>ECUC_UdpNm_00042 :</b>		
<b>Name</b>	UdpNmTxConfirmationPduId		
<b>Description</b>	Id of the TxPdu that will be used by a TxConfirmation from the lower layer.		
<b>Multiplicity</b>	1		
<b>Type</b>	EcucIntegerParamDef (Symbolic Name generated for this parameter)		
<b>Range</b>	0 .. 4294967296		
<b>Default value</b>	--		
<b>Post-Build Variant Value</b>	false		
<b>Value Configuration Class</b>	<b>Pre-compile time</b>	X	All Variants
	<b>Link time</b>	--	
	<b>Post-build time</b>	--	
<b>Scope / Dependency</b>	scope: local		

<b>SWS Item</b>	<b>ECUC_UdpNm_00037 :</b>		
<b>Name</b>	UdpNmTxPduRef		
<b>Description</b>	The reference to a PDU in the global PDU structure described in the AUTOSAR ECU Configuration Specification. This reference will be used by the UdpNm module to derive the PDU Id.		
<b>Multiplicity</b>	1		
<b>Type</b>	Reference to [ Pdu ]		
<b>Post-Build Variant Value</b>	false		
<b>Value Configuration Class</b>	<b>Pre-compile time</b>	X	VARIANT-PRE-COMPILE
	<b>Link time</b>	X	VARIANT-LINK-TIME
	<b>Post-build time</b>	--	
<b>Scope / Dependency</b>	scope: local		

<b>No Included Containers</b>
-------------------------------

### 10.2.7 UdpNmUserDataTxPdu

<b>SWS Item</b>	<b>ECUC_UdpNm_00056 :</b>
<b>Container Name</b>	UdpNmUserDataTxPdu
<b>Description</b>	This optional container is used to configure the UserNm PDU. This container is only available if UdpNmComUserDataSupport is enabled.
<b>Configuration Parameters</b>	

<b>SWS Item</b>	<b>ECUC_UdpNm_00058 :</b>		
<b>Name</b>	UdpNmTxUserDataPduId		
<b>Description</b>	This parameter defines the Handle ID of the NM User Data I-PDU.		
<b>Multiplicity</b>	1		
<b>Type</b>	EcucIntegerParamDef (Symbolic Name generated for this parameter)		
<b>Range</b>	0 .. 65535		
<b>Default value</b>	--		
<b>Post-Build Variant Value</b>	false		
<b>Value Configuration Class</b>	<b>Pre-compile time</b>	X	All Variants
	<b>Link time</b>	--	
	<b>Post-build time</b>	--	
<b>Scope / Dependency</b>	scope: local		

<b>SWS Item</b>	<b>ECUC_UdpNm_00057 :</b>		
<b>Name</b>	UdpNmTxUserDataPduRef		
<b>Description</b>	Reference to the NM User Data I-PDU in the global PDU collection.		
<b>Multiplicity</b>	1		
<b>Type</b>	Reference to [ Pdu ]		
<b>Post-Build Variant Value</b>	false		
<b>Value Configuration Class</b>	<b>Pre-compile time</b>	X	VARIANT-PRE-COMPILE
	<b>Link time</b>	X	VARIANT-LINK-TIME
	<b>Post-build time</b>	--	
<b>Scope / Dependency</b>	scope: local		

<b>No Included Containers</b>
-------------------------------

### 10.2.8 UdpNmDemEventParameterRefs

<b>SWS Item</b>	<b>ECUC_UdpNm_00050 :</b>
<b>Container Name</b>	UdpNmDemEventParameterRefs
<b>Description</b>	Container for the references to DemEventParameter elements which shall be invoked using the API Dem_ReportErrorStatus API in case the corresponding error occurs. The EventId is taken from the referenced DemEventParameter's DemEventId value. The standardized errors are provided in the container and can be extended by vendor specific error references.
<b>Configuration Parameters</b>	

<b>SWS Item</b>	<b>ECUC_UdpNm_00053 : (Obsolete)</b>		
<b>Name</b>	UDPNM_E_NETWORK_TIMEOUT		
<b>Description</b>	Reference to the DemEventParameter which shall be issued when the error "NM-Timeout Timer has abnormally expired outside of the Ready Sleep State" has occurred. <b>Tags:</b> atp.Status=obsolete atp.StatusRevisionBegin=4.2.2		
<b>Multiplicity</b>	0..1		
<b>Type</b>	Symbolic name reference to [ DemEventParameter ]		
<b>Post-Build Multiplicity</b>	<b>Variant</b>	false	
<b>Post-Build Variant Value</b>	false		
<b>Multiplicity Configuration Class</b>	<b>Pre-compile time</b>	X	All Variants
	<b>Link time</b>	--	
	<b>Post-build time</b>	--	
<b>Value Configuration Class</b>	<b>Pre-compile time</b>	X	All Variants
	<b>Link time</b>	--	
	<b>Post-build time</b>	--	
<b>Scope / Dependency</b>	scope: local		

<b>SWS Item</b>	<b>ECUC_UdpNm_00052 : (Obsolete)</b>		
<b>Name</b>	UDPNM_E_TCPIP_TRANSMIT_ERROR		
<b>Description</b>	Reference to the DemEventParameter which shall be issued when the error "A call to the TCP/IP stack has failedA call to the TCP/IP stack has failed" has occurred. <b>Tags:</b> atp.Status=obsolete atp.StatusRevisionBegin=4.2.2		
<b>Multiplicity</b>	0..1		
<b>Type</b>	Symbolic name reference to [ DemEventParameter ]		
<b>Post-Build Multiplicity</b>	<b>Variant</b>	false	
<b>Post-Build Variant Value</b>	false		
<b>Multiplicity Configuration Class</b>	<b>Pre-compile time</b>	X	All Variants
	<b>Link time</b>	--	
	<b>Post-build time</b>	--	
<b>Value Configuration Class</b>	<b>Pre-compile time</b>	X	All Variants
	<b>Link time</b>	--	
	<b>Post-build time</b>	--	
<b>Scope / Dependency</b>	scope: local		

**No Included Containers**

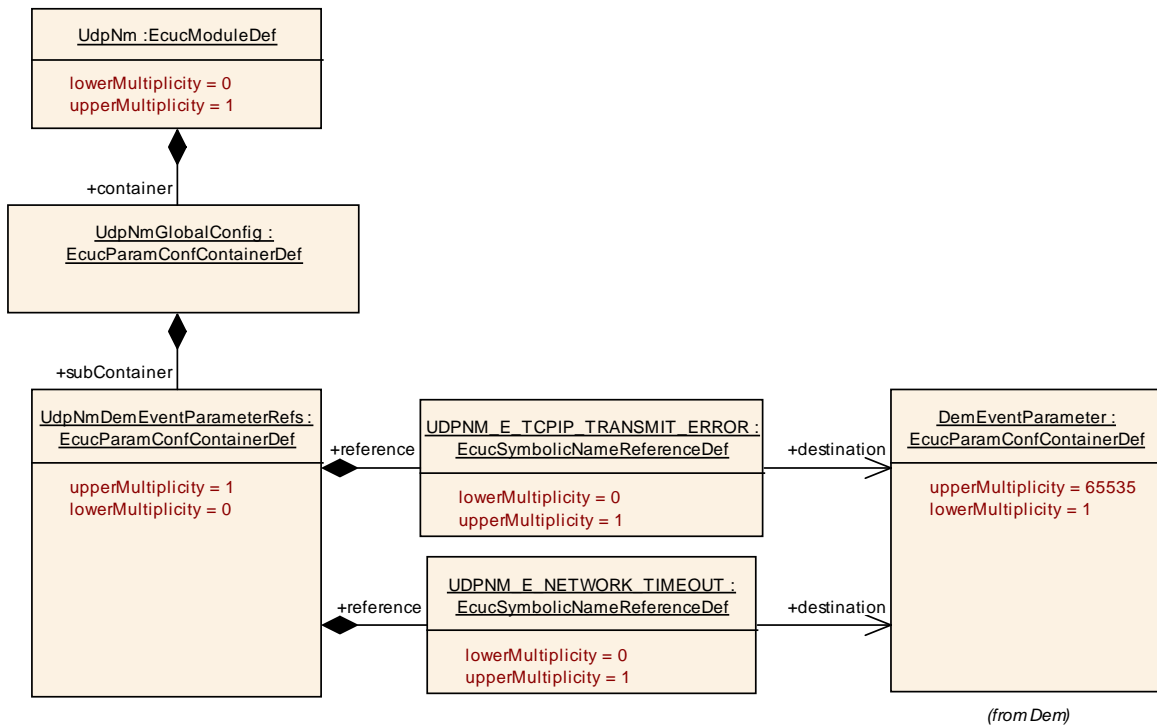

**Figure 11: Diagram: UdpNmDemEventParameterRefs**

**10.2.9 UdpNmPnInfo**

<b>SWS Item</b>	<b>ECUC_UdpNm_00067 :</b>
<b>Container Name</b>	UdpNmPnInfo
<b>Description</b>	PN information configuration
<b>Configuration Parameters</b>	

<b>SWS Item</b>	<b>ECUC_UdpNm_00069 :</b>		
<b>Name</b>	UdpNmPnInfoLength		
<b>Description</b>	Specifies the length of the PN request information in the NM message.		
<b>Multiplicity</b>	1		
<b>Type</b>	EcucIntegerParamDef		
<b>Range</b>	1 .. 7		
<b>Default value</b>	1		
<b>Post-Build Variant Value</b>	false		
<b>Value Configuration Class</b>	<b>Pre-compile time</b>	X	VARIANT-PRE-COMPILE
	<b>Link time</b>	X	VARIANT-LINK-TIME
	<b>Post-build time</b>	--	

<b>Scope / Dependency</b>	scope: local dependency: only available if UdpNmPnEnabled == true for at least one UdpNm Channel.
---------------------------	--

<b>SWS Item</b>	<b>ECUC UdpNm_00068 :</b>		
<b>Name</b>	UdpNmPnInfoOffset		
<b>Description</b>	Specifies the offset of the PN request information in the NM message.		
<b>Multiplicity</b>	1		
<b>Type</b>	EcucIntegerParamDef		
<b>Range</b>	1 .. 7		
<b>Default value</b>	1		
<b>Post-Build Variant Value</b>	false		
<b>Value Configuration Class</b>	<b>Pre-compile time</b>	X	VARIANT-PRE-COMPILE
	<b>Link time</b>	X	VARIANT-LINK-TIME
	<b>Post-build time</b>	--	
<b>Scope / Dependency</b>	scope: local dependency: only available if UdpNmPnEnabled == true for at least one UdpNm Channel.		

<b>Included Containers</b>		
<b>Container Name</b>	<b>Multiplicity</b>	<b>Scope / Dependency</b>
UdpNmPnFilterMaskByte	0..7	PN information configuration

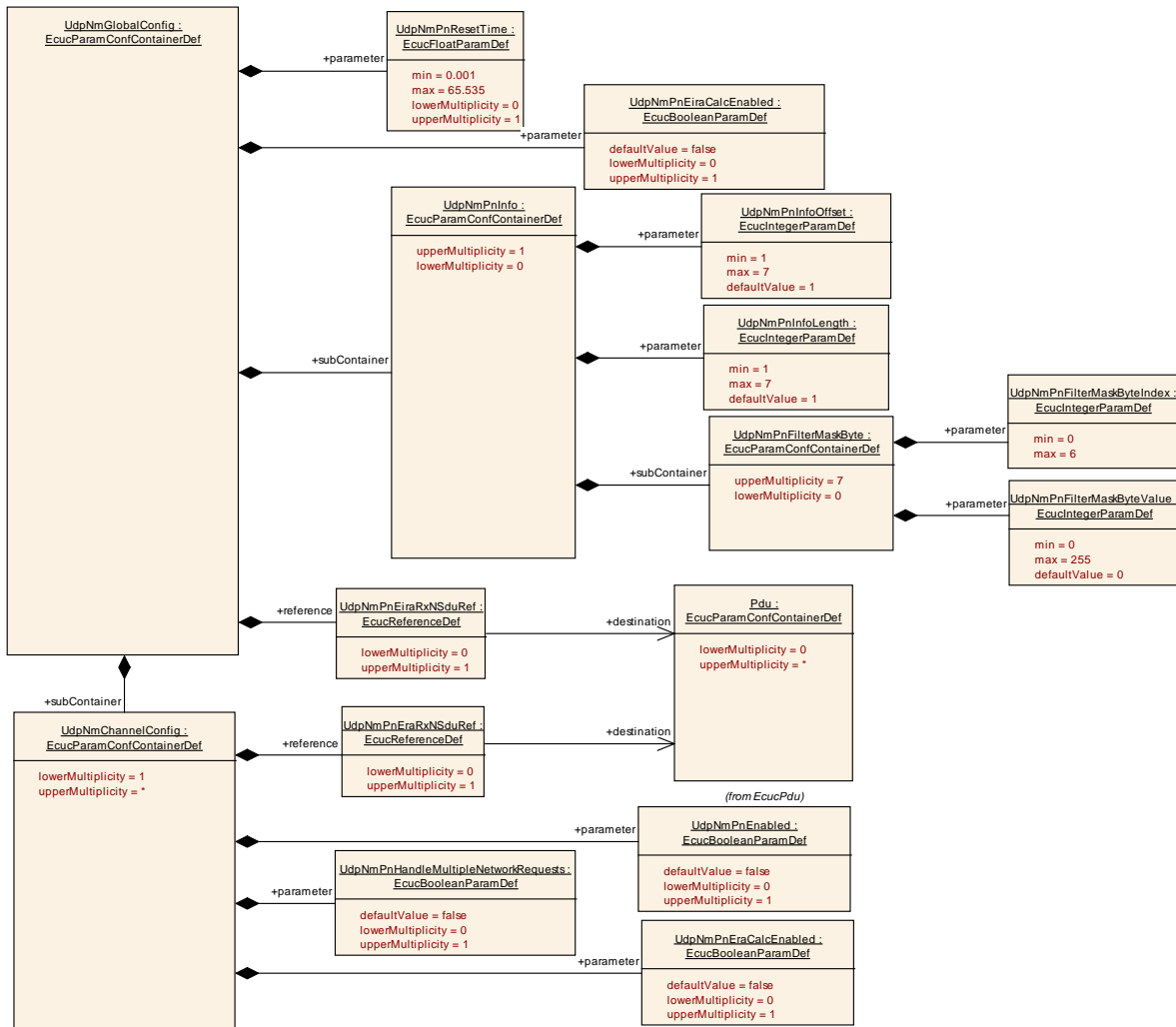

Figure 12: Diagram: UdpNmPNConfig

### 10.2.10 UdpNmPnFilterMaskByte

<b>SWS Item</b>	<b>ECUC_UdpNm_00070 :</b>		
<b>Container Name</b>	UdpNmPnFilterMaskByte		
<b>Description</b>	PN information configuration		
<b>Configuration Parameters</b>			

<b>SWS Item</b>	<b>ECUC_UdpNm_00071 :</b>		
<b>Name</b>	UdpNmPnFilterMaskByteIndex		
<b>Description</b>	Index of the filter mask byte. Specifies the position within the filter mask byte array.		
<b>Multiplicity</b>	1		
<b>Type</b>	EcucIntegerParamDef		
<b>Range</b>	0 .. 6		
<b>Default value</b>	--		
<b>Post-Build Variant Value</b>	false		
<b>Value Configuration Class</b>	<b>Pre-compile time</b>	X	VARIANT-PRE-COMPILE
	<b>Link time</b>	X	VARIANT-LINK-TIME
	<b>Post-build time</b>	--	
<b>Scope / Dependency</b>	scope: local dependency: only available if UdpNmPnEnabled == true for at least one UdpNm Channel. UdpNmPnFilterMaskByteIndex < UdpNmPnInfoLength		

<b>SWS Item</b>	<b>ECUC_UdpNm_00072 :</b>		
<b>Name</b>	UdpNmPnFilterMaskByteValue		
<b>Description</b>	Parameter to configure the filter mask byte.		
<b>Multiplicity</b>	1		
<b>Type</b>	EcucIntegerParamDef		
<b>Range</b>	0 .. 255		
<b>Default value</b>	0		
<b>Post-Build Variant Value</b>	false		
<b>Value Configuration Class</b>	<b>Pre-compile time</b>	X	VARIANT-PRE-COMPILE
	<b>Link time</b>	X	VARIANT-LINK-TIME
	<b>Post-build time</b>	--	
<b>Scope / Dependency</b>	scope: local dependency: only available if UdpNmPnEnabled == true for at least one UdpNm Channel; UdpNmPnFilterMaskByteIndex < UdpNmPnInfoLength		

**No Included Containers**

## 10.3 Published parameters

For details refer to the chapter 10.3 “Published Information” in *SWS\_BSWGeneral*.



## 11 Not applicable requirements

**[SWS\_UdpNm\_00999 ]** [ These requirements are not applicable to this specification. ] (SRS\_BSW\_00170, SRS\_BSW\_00387, SRS\_BSW\_00375, SRS\_BSW\_00416, SRS\_BSW\_00168, SRS\_BSW\_00423, SRS\_BSW\_00424, SRS\_BSW\_00425, SRS\_BSW\_00426, SRS\_BSW\_00427, SRS\_BSW\_00429, SRS\_BSW\_00432, BSW00434, SRS\_BSW\_00336, SRS\_BSW\_00417, SRS\_BSW\_00161, SRS\_BSW\_00162, SRS\_BSW\_00005, SRS\_BSW\_00415, SRS\_BSW\_00164, SRS\_BSW\_00325, SRS\_BSW\_00326, SRS\_BSW\_00160, SRS\_BSW\_00413, SRS\_BSW\_00347, SRS\_BSW\_00305, SRS\_BSW\_00307, SRS\_BSW\_00335, SRS\_BSW\_00410, SRS\_BSW\_00314, SRS\_BSW\_00328, SRS\_BSW\_00312, SRS\_BSW\_00006, SRS\_BSW\_00377, SRS\_BSW\_00306, SRS\_BSW\_00309, SRS\_BSW\_00330, SRS\_BSW\_00331, SRS\_BSW\_00172, SRS\_BSW\_00010, SRS\_BSW\_00333, SRS\_BSW\_00321, SRS\_BSW\_00341, SRS\_BSW\_00334, SRS\_Nm\_00151, SRS\_Nm\_00046, SRS\_Nm\_00050, SRS\_Nm\_00052, SRS\_Nm\_02509, SRS\_Nm\_00153, BSW136, BSW140, SRS\_Nm\_00054, SRS\_Nm\_00142, SRS\_Nm\_00144, SRS\_Nm\_00147, SRS\_Nm\_00154, BSW139, BSW)

] ( )