

Document Title	Specification of a Request Manager for SAE J1939
Document Owner	AUTOSAR
Document Responsibility	AUTOSAR
Document Identification No	611
Document Classification	Standard

Document Status	Final
Part of AUTOSAR Release	4.2.2

Document Change History		
Release	Changed by	Change Description
4.2.2	AUTOSAR Release Management	<ul style="list-style-type: none"> • Fixed names and signatures of service ports • Support for explicit broadcast of ACKM • Introduction of further error classes
4.2.1	AUTOSAR Release Management	<ul style="list-style-type: none"> • Improved interaction with COM • Harmonized with SWS BSW General
4.1.3	AUTOSAR Release Management	<ul style="list-style-type: none"> • Clarified availability of callbacks • Standardized callback header names • Fixed UserType Enum
4.1.2	AUTOSAR Release Management	<ul style="list-style-type: none"> • Additional development error for function parameter checks • Clarification of Request timeout and state handling • Separate configuration of received and transmitted PGNs • Removed change documentation
4.1.1	AUTOSAR Administration	<ul style="list-style-type: none"> • Initial Release

Disclaimer

This specification and the material contained in it, as released by AUTOSAR, is for the purpose of information only. AUTOSAR and the companies that have contributed to it shall not be liable for any use of the specification.

The material contained in this specification is protected by copyright and other types of Intellectual Property Rights. The commercial exploitation of the material contained in this specification requires a license to such Intellectual Property Rights.

This specification may be utilized or reproduced without any modification, in any form or by any means, for informational purposes only. For any other purpose, no part of the specification may be utilized or reproduced, in any form or by any means, without permission in writing from the publisher.

The AUTOSAR specifications have been developed for automotive applications only. They have neither been developed, nor tested for non-automotive applications.

The word AUTOSAR and the AUTOSAR logo are registered trademarks.

Advice for users

AUTOSAR specifications may contain exemplary items (exemplary reference models, "use cases", and/or references to exemplary technical solutions, devices, processes or software).

Any such exemplary items are contained in the specifications for illustration purposes only, and they themselves are not part of the AUTOSAR Standard. Neither their presence in such specifications, nor any later documentation of AUTOSAR conformance of products actually implementing such exemplary items, imply that intellectual property rights covering such exemplary items are licensed under the same rules as applicable to the AUTOSAR Standard.

Table of Contents

1	Introduction and functional overview	6
1.1	Request Management according to SAE J1939	6
1.2	J1939 Request Manager BSW Module	6
1.3	J1939 Terminology	6
2	Acronyms and abbreviations	7
3	Related documentation.....	8
3.1	Input documents	8
3.2	Related standards and norms	9
3.3	Related specification	9
4	Constraints and assumptions	10
4.1	Limitations	10
4.2	Applicability to car domains	10
5	Dependencies to other modules.....	11
5.1	File structure.....	11
5.1.1	Code file structure.....	11
5.1.2	Header file structure.....	11
6	Requirements traceability	13
7	Functional specification	15
7.1	Overview	15
7.2	Module Handling	15
7.2.1	Initialization	15
7.2.2	Timing Related Functionality.....	15
7.3	Communication State Handling	16
7.4	Reception of Requests	16
7.4.1	Request Forwarding.....	16
7.4.2	Request Handling via COM.....	17
7.4.3	Request of Unknown PGNs	17
7.5	Transmission of Acknowledgements	17
7.6	Transmission of Requests	18
7.7	Reception of Acknowledgements	19
7.8	Timeout Supervision.....	20
7.9	Error classification	20
7.9.1	Development Errors	21
7.9.2	Runtime Errors.....	22
7.9.3	Transient Faults	22
7.9.4	Production Errors	22
7.9.5	Extended Production Errors	22
7.10	API Parameter Checking.....	22
8	API specification.....	23
8.1	Imported types.....	23
8.2	Type definitions	23
8.2.1	J1939Rm_ConfigType	23
8.2.2	J1939Rm_StateType	23

8.2.3	J1939Rm_AckCode	23
8.3	Function definitions.....	24
8.3.1	J1939Rm_Init.....	24
8.3.2	J1939Rm_DeInit	24
8.3.3	J1939Rm_GetVersionInfo.....	25
8.3.4	J1939Rm_SetState.....	25
8.3.5	J1939Rm_SendRequest.....	26
8.3.6	J1939Rm_CancelRequestTimeout	27
8.3.7	J1939Rm_SendAck	28
8.4	Call-back notifications.....	29
8.4.1	J1939Rm_RxIndication.....	29
8.4.2	J1939Rm_TxConfirmation	30
8.4.3	J1939Rm_ComRxIpduCallout.....	30
8.5	Scheduled functions	31
8.5.1	J1939Rm_MainFunction	31
8.6	Expected Interfaces.....	31
8.6.1	Mandatory Interfaces	31
8.6.2	Optional Interfaces.....	31
8.6.3	Configurable interfaces	32
8.7	Service Port Descriptions	34
8.7.1	Provided Service Ports	34
8.7.2	Required Service Ports	35
8.7.3	Client-Server Interfaces	36
8.7.4	Implementation Data Types	44
9	Sequence diagrams	46
9.1	Reception of Request PG.....	46
9.2	Transmission of Acknowledgement PG.....	46
9.3	Handling of Request for a COM Pdu	47
9.4	Handling of Request for a Diagnostic Pdu.....	48
9.5	Transmission of Request PG.....	48
9.6	Reception of Acknowledgement PG	49
9.7	Monitoring of Request Timeout	50
10	Configuration specification.....	51
10.1	How to read this chapter	51
10.2	Containers and configuration parameters	51
10.2.1	Variants	56
10.2.2	J1939Rm	56
10.2.3	J1939RmGeneral	57
10.2.4	J1939RmConfigSet.....	59
10.2.5	J1939RmChannel.....	59
10.2.6	J1939RmAckmRxPdu.....	61
10.2.7	J1939RmAckmTxPdu	61
10.2.8	J1939RmRqstRxPdu	62
10.2.9	J1939RmRqstTxPdu.....	63
10.2.10	J1939RmNode.....	63
10.2.11	J1939RmUser.....	64
10.2.12	J1939RmComIPdu	68
10.3	Published Information.....	69

1 Introduction and functional overview

This specification specifies the functionality, API and the configuration of the AUTOSAR Basic Software module J1939 Request Manager.

1.1 Request Management according to SAE J1939

J1939 defines a special parameter group (PG) called Request (RQST, PGN = 0x0EA00), which may be used to request transmission of any other parameter group. The Request parameter group just contains the PGN of the requested parameter group.

Depending on the destination address used by the Request PG, the response must be sent directly to the requesting ECU, or to all ECU. For short parameter groups with PDU1 format, the destination address is set accordingly¹, for large parameter groups the suitable transport protocol mode (BAM or CMDT, see [9] and [18]) is used.

Depending on the requested parameter group and the destination address of the Request PG, ECUs answer either with the requested parameter group, with the special Acknowledgement parameter group (ACKM, PGN = 0x0E800), or not at all.

Finally, J1939 defines that the response to a Request will be expected within 1.25s after the Request was sent. The responding node is required to answer within 200ms.

1.2 J1939 Request Manager BSW Module

The J1939 Request Manager (J1939Rm) handles received and transmitted Request and Acknowledgement PGs. It natively supports handling of incoming requests for address claim and is configurable to support incoming requests for diagnostic and other J1939 PGNs. Unknown incoming requests are answered with a negative Acknowledgement PG if they address a specific destination address.

The J1939Rm also supports transmission of RQST and timeout supervision for the resulting PG or ACKM.

1.3 J1939 Terminology

The terminology of J1939 differs noticeably from the usual AUTOSAR terminology. For consistency reasons, this introduction used the terms of the J1939 specification, while the remainder of this specification will use terms that are more common within AUTOSAR:

- 'I-PDU' replaces 'parameter group'

¹ Short parameter groups with PDU2 format have no destination address, they are broadcast PGs by nature.

2 Acronyms and abbreviations

Abbreviation / Acronym:	Description:
AC	J1939 AddressClaimed PG (PGN = 0x0EE00)
ACK	J1939 Acknowledgement PG (ACKM) with control byte set to 0
ACKM	J1939 Acknowledgement PG (PGN = 0x0E800)
BSW	Basic Software (module)
CA	Controller Application, role of an ECU tied to one address
DET	Default Error Tracer, supports development and runtime error reporting
DP	Data Page, the most significant bit (MSB) of the 18 bit PGN
EDP	Extended Data Page, the second bit (after MSB) of the 18 bit PGN
NACK	J1939 Acknowledgement PG (ACKM) with control byte set to 1
PDUF	PDU Format, the middle byte of the 18 bit PGN
PDUS	PDU Specific, the lower byte of the 18 bit PGN
PG	Parameter Group
PGN	Parameter Group Number (18 bits, contains EDP, DP, PDUF, PDUS)
RQST	J1939 Request PG (PGN = 0x0EA00)
RQST2	J1939 Request2 PG (PGN = 0x0C900)
RTE	AUTOSAR Runtime Environment
SW-C	AUTOSAR Software Component (of the Application)
XFER	J1939 Transfer PG (PGN = 0x0CA00)

3 Related documentation

3.1 Input documents

[1] List of Basic Software Modules
AUTOSAR_TR_BSWModuleList.pdf

[2] Layered Software Architecture
AUTOSAR_EXP_LayeredSoftwareArchitecture.pdf

[3] General Requirements on Basic Software Modules
AUTOSAR_SRS_BSWGeneral.pdf

[4] General Specification of Basic Software Modules
AUTOSAR_SWS_BSWGeneral.pdf

[5] Requirements on BSW Modules for SAE J1939
AUTOSAR_SRS_J1939.pdf

[6] Specification of Communication Stack Types
AUTOSAR_SWS_CommunicationStackTypes.pdf

[7] System Template
AUTOSAR_TPS_SystemTemplate.pdf

[8] Specification of CAN Interface
AUTOSAR_SWS_CANInterface.pdf

[9] Specification of a Transport Layer for SAE J1939
AUTOSAR_SWS_SAEJ1939TransportLayer.pdf

[10] Specification of PDU Router
AUTOSAR_SWS_PDURouter.pdf

[11] Specification of Communication
AUTOSAR_SWS_COM.pdf

[12] Specification of Network Management for SAE J1939
AUTOSAR_SWS_SAEJ1939NetworkManagement.pdf

[13] Specification of a Diagnostic Communication Manager for SAE J1939
AUTOSAR_SWS_SAEJ1939DiagnosticCommunicationManager.pdf

[14] Specification of Default Error Tracer
AUTOSAR_SWS_DefaultErrorTracer.pdf

[15] Specification of BSW Scheduler
AUTOSAR_SWS_BSWScheduler.pdf

[16] Specification of ECU Configuration
AUTOSAR_TPS_ECUConfiguration.pdf

[17] Specification of Memory Mapping
AUTOSAR_SWS_MemoryMapping.pdf

3.2 Related standards and norms

[18] J1939-21 DEC2010, Data Link Layer

3.3 Related specification

AUTOSAR provides a General Specification on Basic Software modules [4] (SWS BSW General), which is also valid for the SAE J1939 Request Manager.

Thus, the specification SWS BSW General shall be considered as additional and required specification for SAE J1939 Transport Layer.

4 Constraints and assumptions

4.1 Limitations

The J1939 Request Manager only implements Request and Acknowledgement PGs. It does not provide support for the Request2 and Transfer PGs.

4.2 Applicability to car domains

J1939 is developed by the SAE as a standard for heavy-duty on-highway, farming, and construction vehicles. It is not applicable to passenger cars or light trucks. The J1939 Request Manager will for now only be used in heavy-duty on-highway vehicles, because other domains are currently excluded by AUTOSAR.

5 Dependencies to other modules

The J1939 Request Manager (J1939Rm) has interfaces towards COM, the PDU Router (PduR), the J1939 Network Management module (J1939Nm), the J1939 Diagnostic Communication Management module (J1939Dcm), the Default Error Tracer (DET), and application software components (SW-Cs) via the AUTOSAR Runtime Environment (RTE). It also supports Complex Drivers (CDD).

The J1939 Request Manager includes header files of COM, J1939Nm, J1939Dcm, PduR, DET, CDDs, and the RTE.

5.1 File structure

5.1.1 Code file structure

For details, refer to the section 5.1.6 "Code file structure" of the SWS BSW General [4].

5.1.2 Header file structure

Besides the files defined in section 5.1.7 "Header file structure" of the SWS BSW General [4], the J1939 Request Manager needs to include the files defined below.

[SWS_J1939Rm_00001] [The implementation and callback header files (J1939Rm.h and J1939Rm_Cbk.h) shall include the file J1939Rm_Types.h.] (SRS_BSW_00415)

[SWS_J1939Rm_00032] [The header file J1939Rm_Types.h shall include the file ComStack_Types.h.] (SRS_BSW_00415)

[SWS_J1939Rm_00114] [J1939Rm shall include the header file Com.h if J1939RmUserType is J1939RM_USER_COM for any configured user.] ()

[SWS_J1939Rm_00111] [J1939Rm shall include the header file J1939Nm_Cbk.h if J1939RmUserType is J1939RM_USER_J1939NM for any configured user.] ()

[SWS_J1939Rm_00112] [J1939Rm shall include the header file J1939Dcm_Cbk.h if J1939RmUserType is J1939RM_USER_J1939DCM for any configured user.] ()

[SWS_J1939Rm_00113] [J1939Rm shall include a header file named <apiServicePrefix>_Cbk.h if J1939RmUserType is J1939RM_USER_CDD for any configured user.] ()

Please note: Complex driver (CDD) APIs use the module prefix configured by the apiServicePrefix of the CDD's module description file.

[SWS_J1939Rm_00110] [J1939Rm shall include the header file Rte_J1939Rm.h if J1939RmUserType is J1939RM_USER_RTE for any configured user.] ()

The following picture shows the include hierarchy of the J1939 Request Manager.

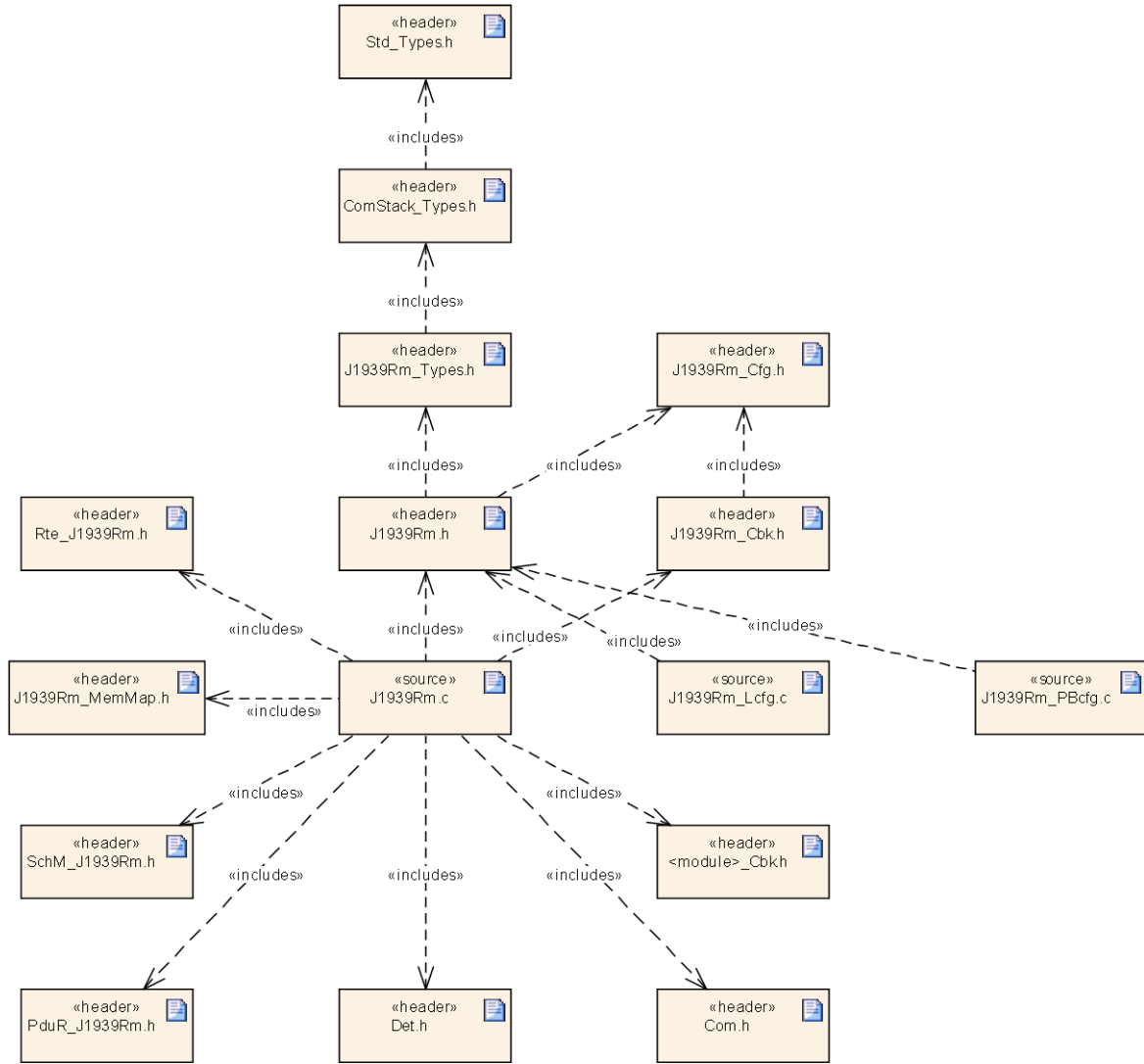

Figure 1: Include hierarchy of J1939Rm

6 Requirements traceability

Requirement	Description	Satisfied by
-	-	SWS_J1939Rm_00010
-	-	SWS_J1939Rm_00011
-	-	SWS_J1939Rm_00014
-	-	SWS_J1939Rm_00015
-	-	SWS_J1939Rm_00031
-	-	SWS_J1939Rm_00033
-	-	SWS_J1939Rm_00035
-	-	SWS_J1939Rm_00036
-	-	SWS_J1939Rm_00040
-	-	SWS_J1939Rm_00041
-	-	SWS_J1939Rm_00042
-	-	SWS_J1939Rm_00043
-	-	SWS_J1939Rm_00044
-	-	SWS_J1939Rm_00045
-	-	SWS_J1939Rm_00046
-	-	SWS_J1939Rm_00048
-	-	SWS_J1939Rm_00049
-	-	SWS_J1939Rm_00057
-	-	SWS_J1939Rm_00058
-	-	SWS_J1939Rm_00059
-	-	SWS_J1939Rm_00062
-	-	SWS_J1939Rm_00067
-	-	SWS_J1939Rm_00068
-	-	SWS_J1939Rm_00069
-	-	SWS_J1939Rm_00070
-	-	SWS_J1939Rm_00071
-	-	SWS_J1939Rm_00072
-	-	SWS_J1939Rm_00074
-	-	SWS_J1939Rm_00075
-	-	SWS_J1939Rm_00076
-	-	SWS_J1939Rm_00079
-	-	SWS_J1939Rm_00080
-	-	SWS_J1939Rm_00081
-	-	SWS_J1939Rm_00082
-	-	SWS_J1939Rm_00083
-	-	SWS_J1939Rm_00084

-	-	SWS_J1939Rm_00085
-	-	SWS_J1939Rm_00086
-	-	SWS_J1939Rm_00087
-	-	SWS_J1939Rm_00096
-	-	SWS_J1939Rm_00109
-	-	SWS_J1939Rm_00110
-	-	SWS_J1939Rm_00111
-	-	SWS_J1939Rm_00112
-	-	SWS_J1939Rm_00113
-	-	SWS_J1939Rm_00114
SRS_BSW_00407	Each BSW module shall provide a function to read out the version information of a dedicated module implementation	SWS_J1939Rm_00039
SRS_BSW_00415	Interfaces which are provided exclusively for one module shall be separated into a dedicated header file	SWS_J1939Rm_00001, SWS_J1939Rm_00032
SRS_J1939_00012	The J1939 Request Manager shall provide an interface for module initialization	SWS_J1939Rm_00012, SWS_J1939Rm_00037, SWS_J1939Rm_00073
SRS_J1939_00013	The J1939 Request Manager shall provide an interface for module shutdown	SWS_J1939Rm_00013, SWS_J1939Rm_00038
SRS_J1939_00014	The J1939 Request Manager shall forward incoming requests to configured destinations	SWS_J1939Rm_00002, SWS_J1939Rm_00003, SWS_J1939Rm_00007, SWS_J1939Rm_00008, SWS_J1939Rm_00063, SWS_J1939Rm_00100, SWS_J1939Rm_00107, SWS_J1939Rm_00115
SRS_J1939_00015	The J1939 Request Manager shall forward incoming acknowledgements to configured destinations	SWS_J1939Rm_00026, SWS_J1939Rm_00027, SWS_J1939Rm_00028, SWS_J1939Rm_00064, SWS_J1939Rm_00066, SWS_J1939Rm_00101, SWS_J1939Rm_00106
SRS_J1939_00016	The J1939 Request Manager shall provide an interface for transmission of request messages	SWS_J1939Rm_00016, SWS_J1939Rm_00021, SWS_J1939Rm_00022, SWS_J1939Rm_00023, SWS_J1939Rm_00025, SWS_J1939Rm_00054, SWS_J1939Rm_00097, SWS_J1939Rm_00104
SRS_J1939_00017	The J1939 Request Manager shall provide an interface for transmission of acknowledgement messages	SWS_J1939Rm_00008, SWS_J1939Rm_00009, SWS_J1939Rm_00018, SWS_J1939Rm_00019, SWS_J1939Rm_00020, SWS_J1939Rm_00056, SWS_J1939Rm_00098, SWS_J1939Rm_00103
SRS_J1939_00026	The J1939 Request Manager shall support timeout supervision for outgoing requests	SWS_J1939Rm_00017, SWS_J1939Rm_00024, SWS_J1939Rm_00029, SWS_J1939Rm_00030, SWS_J1939Rm_00055, SWS_J1939Rm_00065, SWS_J1939Rm_00099, SWS_J1939Rm_00102, SWS_J1939Rm_00105, SWS_J1939Rm_00108

7 Functional specification

This chapter defines the behavior of the J1939 Request Manager. The API of the module is defined in chapter 8, while the configuration is defined in chapter 10.

7.1 Overview

On one side, the J1939 Request Manager is responsible for routing incoming requests to the correct destination, and to provide an infrastructure for sending responding ACKM PGs.

On the other side, the J1939 Request Manager also provides an infrastructure to send RQST PGs, and to supervise timeout of the response(s), including but not limited to ACKM.

7.2 Module Handling

This section contains description of auxiliary functionality of the J1939 Request Manager.

7.2.1 Initialization

The J1939 Request Manager is initialized via J1939Rm_Init, and de-initialized via J1939Rm_Delnit. Except for J1939Rm_GetVersionInfo and J1939Rm_Init, the API functions of the J1939 Request Manager may only be called after the module has been properly initialized.

[SWS_J1939Rm_00012] [A call to J1939Rm_Init initializes all internal variables and sets the J1939 Request Manager to the initialized state.] (SRS_J1939_00012)

[SWS_J1939Rm_00013] [A call to J1939Rm_Delnit sets the J1939 Request Manager back to the uninitialized state.] (SRS_J1939_00013)

[SWS_J1939Rm_00010] [If DET reporting is enabled via J1939RmDevErrorDetect, the J1939 Request Manager shall call Det_ReportError with the error code J1939RM_E_UNINIT when any API other than J1939Rm_Init or J1939Rm_GetVersionInfo is called in uninitialized state.] ()

[SWS_J1939Rm_00011] [When J1939Rm_Init is called in initialized state, the J1939 Request Manager shall not re-initialize its internal variables. It shall instead call Det_ReportError with the error code J1939RM_E_REINIT if DET reporting is enabled (see J1939RmDevErrorDetect).] ()

7.2.2 Timing Related Functionality

To be able to measure times, the J1939 Request Manager is triggered cyclically via the J1939Rm_MainFunction.

[SWS_J1939Rm_00072] [The J1939 Request Manager shall use the J1939Rm_MainFunction for timing related purposes.] ()

7.3 Communication State Handling

In general, request handling is only active when the ECU is online (see [12] for details). The exceptions to this rule are received and transmitted requests for the AddressClaimed PG, which must be possible in all cases. The J1939 Request Manager provides an API that is used by the BSW Mode Manager (BswM) to notify the J1939 communication state.

[SWS_J1939Rm_00073] [During initialization via J1939Rm_Init, the J1939 Request Manager assumes the offline state for all nodes on all channels.] (SRS_J1939_00012)

[SWS_J1939Rm_00014] [A call to J1939Rm_SetState sets the state of a node's channel to online or offline.] ()

[SWS_J1939Rm_00015] [In the offline state, the J1939 Request Manager only processes requests for the AddressClaimed PG, while timeout supervision and acknowledgement handling are completely disabled.] ()

7.4 Reception of Requests

The J1939 Request Manager receives Request PGs (RQST) via J1939Rm_RxIndication from the CAN Interface. The corresponding I-PDU must have a MetaDataLength of 4 to be able to identify the sender, the destination address, and the priority of the request.

[SWS_J1939Rm_00007] [The J1939 Request Manager shall only accept requests addressed to the whole network (global DA), or to one of the configured addresses of the ECU (see J1939RmNmNodeRef).] (SRS_J1939_00014)

Requests for the AddressClaimed PG (AC, PGN = 0x0EE00) always go to the J1939 Network Management module, and requests for the DMx PGs (DM1 to DM52) to the J1939 Diagnostic Communication Manager. The destination of these and other PGNs is configured via J1939RmUserPGN.

Besides forwarding to the J1939 Network Management module, the J1939 Diagnostic Communication Manager, and CDDs, the J1939 Request Manager can also forward requests to SW-Cs, and trigger COM to send requested PGs.

7.4.1 Request Forwarding

Forwarding to other BSW modules is done via the generic callout function <User>_RequestIndication (see section 8.6.3.1). Forwarding to SW-C uses a dedicated service port function with the same signature as the <User>_RequestIndication.

[SWS_J1939Rm_00002] [When J1939Rm_RxIndication is called by the PDU Router to indicate reception of a request, and the requested PGN is configured via J1939RmUserPGN to trigger either the J1939 Network Management module, the J1939 Diagnostic Communication Manager, or a CDD, the J1939 Request Manager shall call the corresponding <User>_RequestIndication.] (SRS_J1939_00014)

[SWS_J1939Rm_00003] [When J1939Rm_RxIndication is called by the PDU Router to indicate reception of a request, and the requested PGN is configured via J1939RmUserPGN to be forwarded to the RTE, the J1939 Request Manager shall call the corresponding service port function.] (SRS_J1939_00014)

7.4.2 Request Handling via COM

If COM is configured as destination for the request of a certain PGN, the J1939 Request Manager will prepare the MetaData, and request COM to send the PDU with the MetaData provided via Com_TriggerIPDUSendWithMetaData. This sequence is shown in Figure 4.

[SWS_J1939Rm_00115] [When J1939Rm_RxIndication is called by the PDU Router to indicate reception of a request, and the requested PGN is configured via J1939RmComIPduPGN to be handled via COM, the J1939 Request Manager shall prepare the MetaData from the given information and provide it to COM via Com_TriggerIPDUSendWithMetaData together with the PduId of the transmitted COM I-PDU referenced by J1939RmComIPduRef.] (SRS_J1939_00014)

7.4.3 Request of Unknown PGNs

The J1939 Request Manager shall respond to requests for unknown PGNs with a NACK, but only when the request was sent to a specific destination address.

[SWS_J1939Rm_00008] [When J1939Rm_RxIndication is called by the PDU Router to indicate reception of a request, and the requested PGN is not configured, and the destination address is not the broadcast address, the J1939 Request Manager shall call PduR_J1939RmTransmit to send a negative acknowledgement (NACK).] (SRS_J1939_00014, SRS_J1939_00017)

7.5 Transmission of Acknowledgements

For unknown PGNs, the J1939 Request Manager transmits a negative acknowledgement by itself (see section 7.4.3 above). Modules that receive requests from the J1939 Request Manager may use the API J1939Rm_SendAck to transmit the acknowledgement variants defined by the J1939 standard (see section 5.4.4 in [18] and description of the API J1939Rm_SendAck in section 8.3.7).

The Acknowledgement PG is supposed to have a fixed destination address (FF₁₆), configured via CanIfTxPduCanId in the CAN Interface. The MetaDataLength shall be 4 so that the J1939 Request Manager can modify the priority and source address.

[SWS_J1939Rm_00009] [When a BSW module, a CDD, or an SW-C (via service port and RTE) calls J1939Rm_SendAck, the J1939 Request Manager shall call PduR_J1939RmTransmit to send the required acknowledgement.] (SRS_J1939_00017)

There is only one I-PDU available to send Acknowledgement PGs. Still, it must be ensured, that no Acknowledgement PG is lost, even when a new transmission is initiated while this I-PDU is already occupied by another transmission. To achieve this, the J1939 Request Manager needs to queue Acknowledgement PGs.

[SWS_J1939Rm_00018] [Transmission requests for the Acknowledgement PG shall be queued when a previous transmission of this PG is still pending. The size of this queue is determined by J1939RmAckQueueSize.] (SRS_J1939_00017)

[SWS_J1939Rm_00019] [The J1939 Request Manager shall use the J1939Rm_TxConfirmation of the associated I-PDU to trigger transmission of pending Acknowledgement PGs.] (SRS_J1939_00017)

[SWS_J1939Rm_00020] [If the J1939Rm_TxConfirmation is not called within J1939RmTxConfirmationTimeout seconds, the J1939 Request Manager shall flush the Acknowledgement PG queue.] (SRS_J1939_00017)

The acknowledgement type (Control byte) and the Address parameter of the Acknowledgement PG are set according to the arguments of the J1939Rm_SendAck function, as described in section 8.3.7. The destination address is always the global address, as defined in [18].

7.6 Transmission of Requests

As stated in section 7.1, the J1939 Request Manager also supports transmission of requests, reception of responding acknowledgements, and timeout supervision for the responses.

To trigger the transmission of a request, the J1939 Request Manager provides the API J1939Rm_SendRequest.

The I-PDU used for the Request PG must have a MetaDataLength of 4 to be able to set the priority, the source and the destination address freely. The CAN Interface must be configured such that the PDUF and data page bits are fixed, while the remaining bits of the CAN ID are variable.

[SWS_J1939Rm_00016] [When a BSW module, a CDD, or an SW-C (via service port and RTE) calls J1939Rm_SendRequest, the J1939 Request Manager shall call PduR_J1939RmTransmit to send the request.] (SRS_J1939_00016)

There is only one I-PDU available to send Request PGs. Still, it must be ensured that no Request PG is lost, even when a new transmission is initiated while this I-PDU is

already occupied by another transmission. To achieve this, the J1939 Request Manager needs to queue Request PGs.

[SWS_J1939Rm_00021] [Transmission requests for the Request PG shall be queued when a previous transmission of this PG is still pending. The size of this queue is determined by J1939RmRequestQueueSize.] (SRS_J1939_00016)

[SWS_J1939Rm_00022] [The J1939 Request Manager shall use the J1939Rm_TxConfirmation of the associated I-PDU to trigger transmission of pending Request PGs.] (SRS_J1939_00016)

[SWS_J1939Rm_00023] [If the J1939Rm_TxConfirmation is not called within J1939RmTxConfirmationTimeout seconds, the J1939 Request Manager shall flush the Request PG queue.] (SRS_J1939_00016)

To be able to do timeout supervision, the J1939 Request Manager needs to remember the initiator, the destination address and the PGN of the request.

[SWS_J1939Rm_00024] [When J1939Rm_SendRequest is called with the parameter checkTimeout set to TRUE and a destination address that is not the broadcast address (0xff), and timeout handling is enabled for the caller via J1939RmUserTimeoutSupervision: The J1939 Request Manager shall store (separately for each node) the calling module's user ID, the PGN, the source address, and the destination address of the request.] (SRS_J1939_00026)

Finally, requests to the global address must also be handled internally as described in section 7.4.

[SWS_J1939Rm_00025] [When a request is sent with the global destination address, it shall also be handled internally as if it was received via J1939Rm_RxIndication.] (SRS_J1939_00016)

7.7 Reception of Acknowledgements

The J1939 Request Manager receives Acknowledgement PGs (ACKM) via J1939Rm_RxIndication from the CAN Interface. The corresponding I-PDU must have a MetaDataLength of 4 to be able to identify the priority and the sender of the request.

[SWS_J1939Rm_00026] [The J1939 Request Manager shall only accept acknowledgements where the AddressAcknowledged is set to one of the configured addresses of the ECU (see J1939RmNmNodeRef).] (SRS_J1939_00015)

The scheduling of received Acknowledgement PGs is configured similarly to the Request PG, see section 7.4.1, but the destinations are restricted to CDD and Application, because the J1939Nm and the J1939Dcm currently do not need to request any information from other ECUs.

[SWS_J1939Rm_00066] [When J1939Rm_RxIndication is called by the PDU Router to indicate reception of an acknowledgement which matches a pending request (acknowledged PGN, source address, acknowledged address), the J1939 Request Manager shall call the <User>_AckIndication or the service port function corresponding to the stored user ID.] (SRS_J1939_00015)

[SWS_J1939Rm_00027] [When J1939Rm_RxIndication is called by the PDU Router to indicate reception of an acknowledgement which does not match a pending request, and the acknowledged PGN is configured via J1939RmUserPGN to trigger a CDD, the J1939 Request Manager shall call the corresponding <User>_AckIndication.] (SRS_J1939_00015)

[SWS_J1939Rm_00028] [When J1939Rm_RxIndication is called by the PDU Router to indicate reception of an acknowledgement which does not match a pending request, and the acknowledged PGN is configured via J1939RmUserPGN to be forwarded to the RTE, the J1939 Request Manager shall call the corresponding service port function.] (SRS_J1939_00015)

7.8 Timeout Supervision

The SAE J1939 specification [18] defines a maximum delay of 200ms for the answer to a request. This delay is not supervised by the J1939 Request Manager. On the other hand, the timeout of 1.25s for the reception of the answer to a request will be supervised by the J1939 Request Manager, if configured accordingly via J1939RmUserTimeoutSupervision. In that case, when the request is transmitted, the timer is started and the request data is stored as described in [SWS_J1939Rm_00024].

[SWS_J1939Rm_00017] [If timeout supervision is enabled for the caller of J1939Rm_SendRequest via J1939RmUserTimeoutSupervision, and the parameter checkTimeout is TRUE, and the destination address is not the broadcast address (0xff): The J1939 Request Manager shall start timeout supervision.] (SRS_J1939_00026)

[SWS_J1939Rm_00029] [When an acknowledgement matching the request is received, when a configured COM RxIPduCallout is triggered which matches the request, or when a CDD or an application SW-C calls J1939Rm_CancelRequestTimeout, the timeout supervision of the request is stopped.] (SRS_J1939_00026)

[SWS_J1939Rm_00030] [If the timeout supervision for a request reaches 1.25s, the J1939 Request Manager shall call the <User>_RequestTimeoutIndication corresponding to the userId parameter of the initial J1939Rm_SendRequest.] (SRS_J1939_00026)

7.9 Error classification

The J1939 Request Manager supports reporting of development and runtime errors.

7.9.1 Development Errors

The supported development errors are defined in the following table.

[SWS_J1939Rm_00031] [

Table of development errors used by the J1939 Request Manager:

<i>Type or error</i>	<i>Relevance</i>	<i>Related error code</i>	<i>Value [hex]</i>
An API was called while the module was uninitialized	Development	J1939RM_E_UNINIT	0x01
The Init API was called twice	Development	J1939RM_E_REINIT	0x02
J1939Rm_Init was called with an invalid configuration pointer	Development	J1939RM_E_INIT_FAILED	0x03
An API service was called with a NULL pointer	Development	J1939RM_E_PARAM_POINTER	0x10
An API service was called with a wrong ID	Development	J1939RM_E_INVALID_PDU_SDU_ID	0x11
An API service was called with wrong network handle	Development	J1939RM_E_INVALID_NETWORK_ID	0x12
The API J1939Rm_SetState was called with a wrong state	Development	J1939RM_E_INVALID_STATE	0x13
An API was called with an illegal user ID	Development	J1939RM_E_INVALID_USER	0x14
An API was called with an unknown or illegal PGN	Development	J1939RM_E_INVALID_PGN	0x15
An API was called with an illegal priority	Development	J1939RM_E_INVALID_PRIO	0x16
An API was called with an illegal node address	Development	J1939RM_E_INVALID_ADDRESS	0x17
An API was called with an illegal Boolean option	Development	J1939RM_E_INVALID_OPTION	0x18
An API was called with an illegal AckCode	Development	J1939RM_E_INVALID_ACK_CODE	0x19
An API was called with an illegal node ID	Development	J1939RM_E_INVALID_NODE	0x1a

Development error values are of type uint8.

] ()

7.9.2 Runtime Errors

Runtime errors have not yet been classified.

7.9.3 Transient Faults

There are no transient faults.

7.9.4 Production Errors

There are no production errors.

7.9.5 Extended Production Errors

There are no extended production errors.

7.10 API Parameter Checking

The J1939 Request Manager performs parameter checks for all called APIs. It reports the development error J1939NM_E_PARAM_POINTER when a call provides a NULL pointer, J1939RM_E_INVALID_PDU_SDU_ID when a check of a PDU/SDU ID fails, J1939RM_E_INVALID_NETWORK_ID when a check of a network handle fails, and J1939RM_E_INVALID_NODE_ID when a check of a node handle fails.

J1939RM_E_PARAM_POINTER shall be reported as specified in [4] by SWS_BSW_00212.

[SWS_J1939Rm_00033] [If DET reporting is enabled via J1939RmDevErrorDetect, the J1939 Request Manager shall check PduIdType parameters (SDU/PDU IDs) of its API functions against the configured IDs, and shall report the development error J1939RM_E_INVALID_PDU_SDU_ID when an unknown ID is provided by the call.] ()

[SWS_J1939Rm_00041] [If DET reporting is enabled via J1939RmDevErrorDetect, the J1939 Request Manager shall check NetworkHandleType parameters (network handles) of its API functions against the referenced network handles of ComM, and shall report the development error J1939RM_E_INVALID_NETWORK_ID when an unknown handle is provided by the call.] ()

[SWS_J1939Rm_00096] [If DET reporting is enabled via J1939RmDevErrorDetect, the J1939 Request Manager shall check node handle parameters of its API functions against the node handles of J1939Nm referenced via J1939RmNmNodeRef, and shall report the development error J1939RM_E_INVALID_NODE_ID when an unknown handle is provided by the call.] ()

8 API specification

8.1 Imported types

In this section, all types used by the J1939 Request Manager are listed together with the defining module:

[SWS_J1939Rm_00035] [

Module	Imported Type
ComStack_Types	NetworkHandleType
	PdulIdType
	PduInfoType
Std_Types	Std_ReturnType
	Std_VersionInfoType

] ()

8.2 Type definitions

8.2.1 J1939Rm_ConfigType

[SWS_J1939Rm_00036] [

Name:	J1939Rm_ConfigType
Type:	Structure
Range:	implementation specific--
Description:	<p>This is the base type for the configuration of the J1939 Request Manager.</p> <p>A pointer to an instance of this structure will be used in the initialization of the J1939 Request Manager.</p> <p>The content of this structure is defined in chapter 10 Configuration specification.</p>

] ()

8.2.2 J1939Rm_StateType

[SWS_J1939Rm_00049] [

Name:	J1939Rm_StateType
Type:	Enumeration
Range:	J1939RM_STATE_ONLINE Normal communication (0)
	J1939RM_STATE_OFFLINE Only Request for AC (1)
Description:	This type represents the communication state of the J1939 Request Manager.

] ()

8.2.3 J1939Rm_AckCode

[SWS_J1939Rm_00057] [

Name:	J1939Rm_AckCode	
Type:	Enumeration	
Range:	J1939RM_ACK_POSITIVE	Positive Acknowledgement (0)
	J1939RM_ACK_NEGATIVE	Negative Acknowledgement (1)
	J1939RM_ACK_ACCESS_DENIED	Access Denied (2)
	J1939RM_ACK_CANNOT_RESPOND	Cannot Respond (3)
Description:	This type represents the available kinds of acknowledgements.	

] ()

8.3 Function definitions

This is a list of functions provided for upper layer modules.

8.3.1 J1939Rm_Init

[SWS_J1939Rm_00037] [

Service name:	J1939Rm_Init	
Syntax:	<pre>void J1939Rm_Init(const J1939Rm_ConfigType* configPtr)</pre>	
Service ID[hex]:	0x01	
Sync/Async:	Synchronous	
Reentrancy:	Non Reentrant	
Parameters (in):	configPtr	Pointer to selected configuration structure
Parameters (inout):	None	
Parameters (out):	None	
Return value:	None	
Description:	This function initializes the J1939 Request Manager.	

] (SRS_J1939_00012)

See section 7.2.1 for details.

See section 7.10 for parameter checks.

J1939RM_E_INIT_FAILED shall be reported as specified in [4] by SWS_BSW_00050.

8.3.2 J1939Rm_DeInit

[SWS_J1939Rm_00038] [

Service name:	J1939Rm_DeInit	
Syntax:	<pre>void J1939Rm_DeInit(void)</pre>	
Service ID[hex]:	0x02	
Sync/Async:	Synchronous	
Reentrancy:	Non Reentrant	

Parameters (in):	None
Parameters (inout):	None
Parameters (out):	None
Return value:	None
Description:	This function resets the J1939 Request Manager to the uninitialized state.

] (SRS_J1939_00013)

See section 7.2.1 for details.

8.3.3 J1939Rm_GetVersionInfo

[SWS_J1939Rm_00039] [

Service name:	J1939Rm_GetVersionInfo
Syntax:	<pre>void J1939Rm_GetVersionInfo(Std_VersionInfoType* versionInfo)</pre>
Service ID[hex]:	0x03
Sync/Async:	Synchronous
Reentrancy:	Non Reentrant
Parameters (in):	None
Parameters (inout):	None
Parameters (out):	versionInfo Pointer to where to store the version information of this module.
Return value:	None
Description:	Returns the version information of this module.

] (SRS_BSW_00407)

See section 8.3.4 “Get Version Information” of [4] for details.

See section 7.10 for parameter checks.

8.3.4 J1939Rm_SetState

[SWS_J1939Rm_00048] [

Service name:	J1939Rm_SetState
Syntax:	<pre>Std_ReturnType J1939Rm_SetState(NetworkHandleType channel, uint8 node, J1939Rm_StateType newState)</pre>
Service ID[hex]:	0x05
Sync/Async:	Synchronous
Reentrancy:	Reentrant
Parameters (in):	channel Channel for which the state shall be changed.
	node Node for which the state shall be changed.
	newState New state the J1939Rm shall enter, see definition of J1939Rm_StateType for available states.
Parameters (inout):	None

Parameters (out):	None	
Return value:	Std_ReturnType	E_OK: New communication state was set E_NOT_OK: Communication state was not changed due to wrong value in NewState or wrong initialization state of the module.
Description:	Changes the communication state of J1939Rm to offline (only Request for AC supported) or online.	

] ()

[SWS_J1939Rm_00040] [The J1939 Request Manager shall reject the state change by returning E_NOT_OK when the 'newState' is not in the valid range. If DET is enabled via J1939RmDevErrorDetect, the development error J1939RM_E_INVALID_STATE (see section 7.9) shall be reported.] ()

See section 7.2.1 for error handling and section 7.10 for parameter checks.

8.3.5 J1939Rm_SendRequest

[SWS_J1939Rm_00054] [

Service name:	J1939Rm_SendRequest	
Syntax:	Std_ReturnType J1939Rm_SendRequest (uint8 userId, NetworkHandleType channel, uint32 requestedPgn, uint8 destAddress, uint8 priority, boolean checkTimeout)	
Service ID[hex]:	0x07	
Sync/Async:	Synchronous	
Reentrancy:	Reentrant	
Parameters (in):	userId	Identification of the calling module.
	channel	Channel on which the request shall be sent.
	requestedPgn	PGN of the requested PG.
	destAddress	Address of the destination node or 0xFF for broadcast.
	priority	Priority of the Request PG.
	checkTimeout	TRUE: Timeout supervision will be performed FALSE: No timeout supervision will be started
Parameters (inout):	None	
Parameters (out):	None	
Return value:	Std_ReturnType	E_OK: Transmission request is accepted E_NOT_OK: Transmission request is not accepted
Description:	Requests transmission of a Request PG.	

] (SRS_J1939_00016)

[SWS_J1939Rm_00074] [The J1939Rm_SendRequest API function shall only be available if J1939RmUserSendRequest is set for at least one user.] ()

See section 7.6 for details.

[SWS_J1939Rm_00067] [The J1939 Request Manager shall reject transmission of a request by returning E_NOT_OK when the 'requestedPgn', the 'destAddress', or the 'priority' are not in the valid range, or when the 'userId' is not one of the configured user IDs (see J1939RmUserId), or when 'checkTimeout' is true but timeout handling is disabled for the calling module (see J1939RmUserTimeoutSupervision). If DET is enabled via J1939RmDevErrorDetect, the corresponding development error (see section 7.9) shall be reported: J1939RM_E_INVALID_USER for 'userId', J1939RM_E_INVALID_PGN for 'requestedPgn', J1939RM_E_INVALID_PRIO for 'priority', J1939RM_E_INVALID_ADDRESS for 'destAddress' or 'sourceAddress', and J1939RM_E_INVALID_OPTION for 'checkTimeout'.] ()

[SWS_J1939Rm_00068] [The J1939 Request Manager shall reject transmission of a request by returning E_NOT_OK when another request is pending and the request queue is full.] ()

See section 7.2.1 for further error handling and section 7.10 for further parameter checks.

8.3.6 J1939Rm_CancelRequestTimeout

[SWS_J1939Rm_00055] [

Service name:	J1939Rm_CancelRequestTimeout	
Syntax:	Std_ReturnType J1939Rm_CancelRequestTimeout (uint8 userId, NetworkHandleType channel, uint32 requestedPgn, uint8 destAddress)	
Service ID[hex]:	0x08	
Sync/Async:	Synchronous	
Reentrancy:	Reentrant	
Parameters (in):	userId	Identification of the calling module.
	channel	Channel on which the request was sent.
	requestedPgn	PGN of the requested PG.
	destAddress	Address of the destination node or 0xFF for broadcast.
Parameters (inout):	None	
Parameters (out):	None	
Return value:	Std_ReturnType	E_OK: Cancellation of request timeout was successful E_NOT_OK: Cancellation of request timeout was not successful
	Description: Cancels timeout monitoring of a Request. If the request is not active, or timeout monitoring was not requested, this call has no effect.	

] (SRS_J1939_00026)

[SWS_J1939Rm_00075] [The J1939Rm_CancelRequestTimeout API function shall only be available if J1939RmUserTimeoutSupervision is set for at least one user.] ()

See section 7.8 for details.

[SWS_J1939Rm_00069] [The J1939 Request Manager shall ignore the timeout cancellation request when the 'requestedPgn' or the 'destAddress' are not in the valid range, or when the 'userId' is not one of the configured user IDs (see J1939RmUserId), or if no suitable entry can be found in the list of pending requests. If DET is enabled via J1939RmDevErrorDetect, the corresponding development error (see section 7.9) shall be reported: J1939RM_E_INVALID_USER for 'userId', J1939RM_E_INVALID_PGN for 'requestedPgn', and J1939RM_E_INVALID_ADDRESS for 'destAddress' or 'sourceAddress'.] ()

See section 7.2.1 for further error handling and section 7.10 for further parameter checks.

8.3.7 J1939Rm_SendAck

[SWS_J1939Rm_00056] [

Service name:	J1939Rm_SendAck	
Syntax:	Std_ReturnType J1939Rm_SendAck(uint8 userId, NetworkHandleType channel, uint32 ackPgn, J1939Rm_AckCode ackCode, uint8 ackAddress, uint8 priority, boolean broadcast)	
Service ID[hex]:	0x09	
Sync/Async:	Synchronous	
Reentrancy:	Reentrant	
Parameters (in):	userId	Identification of the calling module.
	channel	Channel on which the acknowledgement shall be sent.
	ackPgn	Acknowledged PGN.
	ackCode	Type of acknowledgement, see definition of J1939Rm_AckCode for available codes.
	ackAddress	Address of the node that sent the request.
	priority	Priority of the Acknowledgement PG.
	broadcast	Indicates whether the ACKM is a response to a broadcast request.
Parameters (inout):	None	
Parameters (out):	None	
Return value:	Std_ReturnType	E_OK: Transmission request is accepted E_NOT_OK: Transmission request is not accepted
Description:	Requests transmission of an Acknowledgement PG.	

] (SRS_J1939_00017)

[SWS_J1939Rm_00076] [The J1939Rm_SendAck API function shall only be available if J1939RmUserSendAck is set for at least one user.] ()

See section 7.5 for details.

[SWS_J1939Rm_00070] [The J1939 Request Manager shall reject transmission of an acknowledgement by returning E_NOT_OK when the 'ackPgn', the 'ackAddress',

or the 'priority' are not in the valid range, or when the 'userId' is not one of the configured user IDs (see J1939RmUserId). If DET is enabled via J1939RmDevErrorDetect, the corresponding development error (see section 7.9) shall be reported: J1939RM_E_INVALID_PGN for 'ackPgn', J1939RM_E_INVALID_ACK_CODE for 'ackCode', J1939RM_E_INVALID_ADDRESS for 'destAddress' or 'sourceAddress', and J1939RM_E_INVALID_PRIO for 'priority'.] ()

[SWS_J1939Rm_00071] [The J1939 Request Manager shall reject transmission of an acknowledgement by returning E_NOT_OK when another acknowledgement is pending and the acknowledgement queue is full.] ()

See section 7.2.1 for further error handling and section 7.10 for further parameter checks.

8.4 Call-back notifications

This is a list of functions provided for other modules. The function prototypes of the callback functions shall be provided in the file J1939Rm_Cbk.h

8.4.1 J1939Rm_RxIndication

[SWS_J1939Rm_00058] [

Service name:	J1939Rm_RxIndication	
Syntax:	void J1939Rm_RxIndication(PduIdType RxPduId, const PduInfoType* PduInfoPtr)	
Service ID[hex]:	0x42	
Sync/Async:	Synchronous	
Reentrancy:	Reentrant for different PduIds. Non reentrant for the same PduId.	
Parameters (in):	RxPduId	ID of the received I-PDU.
	PduInfoPtr	Contains the length (SduLength) of the received I-PDU and a pointer to a buffer (SduDataPtr) containing the I-PDU.
Parameters (inout):	None	
Parameters (out):	None	
Return value:	None	
Description:	Indication of a received I-PDU from a lower layer communication interface module.	

] ()

[SWS_J1939Rm_00080] [The J1939Rm_RxIndication call back function shall only be available if J1939RmUserAckIndication or J1939RmUserRequestIndication is set for at least one user.] ()

See sections 7.4 and 7.7 for details.

See section 7.2.1 for error handling and section 7.10 for parameter checks.

8.4.2 J1939Rm_TxConfirmation

[SWS_J1939Rm_00059] [

Service name:	J1939Rm_TxConfirmation
Syntax:	void J1939Rm_TxConfirmation(PduIdType TxPduId)
Service ID[hex]:	0x40
Sync/Async:	Synchronous
Reentrancy:	Reentrant for different Pdulds. Non reentrant for the same Pdul.
Parameters (in):	TxPdul ID of the I-PDU that has been transmitted.
Parameters (inout):	None
Parameters (out):	None
Return value:	None
Description:	The lower layer communication interface module confirms the transmission of an I-PDU.

] ()

[SWS_J1939Rm_00081] [The J1939Rm_TxConfirmation call back function shall only be available if J1939RmUserSendAck or J1939RmUserSendRequest is set for at least one user.] ()

See sections 7.5 and 7.6 for details.

See section 7.2.1 for error handling and section 7.10 for parameter checks.

8.4.3 J1939Rm_ComRxIpduCallout

[SWS_J1939Rm_00062] [

Service name:	J1939Rm_ComRxIpduCallout
Syntax:	boolean J1939Rm_ComRxIpduCallout(PduIdType PduId, const PduInfoType* PduInfoPtr)
Service ID[hex]:	0x28
Sync/Async:	Synchronous
Reentrancy:	don't care
Parameters (in):	Pdul ID of the received I-PDU. PduInfoPtr Contains the length (SduLength) of the received I-PDU and a pointer to the data of the I-PDU (SduDataPtr).
Parameters (inout):	None
Parameters (out):	None
Return value:	boolean true: I-PDU will be processed normal false: I-PDU will not be processed any further
Description:	The I-PDU callout on receiver side can be configured to implement user-defined receive filtering mechanisms.

] ()

[SWS_J1939Rm_00079] [The J1939Rm_ComRxIpduCallout call back function shall only be available if a user with J1939RmUserType J1939RM_USER_COM is configured.] ()

See section 7.8 for details.

See section 7.2.1 for error handling and section 7.10 for parameter checks.

8.5 Scheduled functions

This function is directly called by Basic Software Scheduler (SchM).

8.5.1 J1939Rm_MainFunction

[SWS_J1939Rm_00042] [

Service name:	J1939Rm_MainFunction
Syntax:	void J1939Rm_MainFunction(void)
Service ID[hex]:	0x04
Description:	Main function of the J1939 Request Manager. Used for scheduling purposes and timeout supervision.

] ()

[SWS_J1939Rm_00043] [The frequency of invocations of J1939Rm_MainFunction is determined by the configuration parameter J1939RmMainFunctionPeriod.] ()

8.6 Expected Interfaces

In this section, all interfaces required from other modules are listed.

8.6.1 Mandatory Interfaces

This section defines all interfaces that are required to fulfill the core functionality of the module.

[SWS_J1939Rm_00044][[

API function	Description
PduR_J1939RmTransmit	Requests transmission of an I-PDU.

] ()

8.6.2 Optional Interfaces

This section defines all interfaces that are required to fulfill an optional functionality of the module.

[SWS_J1939Rm_00045] [

API function	Description
Com_TriggerIPDUWithMetaData	By a call to Com_TriggerIPDUWithMetaData the AUTOSAR COM module updates its internal metadata for the I-PDU with the given ID by copying the metadata from the given position and with respect to the globally configured metadata length of the I-PDU. Then the I-PDU is triggered for transmission.
Det_ReportError	Service to report development errors.
J1939Dcm_RequestIndication	Indicates reception of a Request PG.
J1939Nm_RequestIndication	Indicates reception of a Request PG.

] ()

[SWS_J1939Rm_00082] [The Com_TriggerIPDUWithMetaData function is only required if a user with J1939RmUserType J1939RM_USER_COM is configured.] ()

[SWS_J1939Rm_00083] [The J1939Dcm_RequestIndication function is only required if a user with J1939RmUserType J1939RM_USER_J1939DCM is configured.] ()

[SWS_J1939Rm_00084] [The J1939Nm_RequestIndication function is only required if a user with J1939RmUserType J1939RM_USER_J1939NM is configured.] ()

8.6.3 Configurable interfaces

In this section, all interfaces are listed where the target function could be configured. The target function is usually a call-back function. The name of this kind of interfaces is not fixed because they are configurable.

8.6.3.1 <User>_RequestIndication

[SWS_J1939Rm_00063] [

Service name:	< User >_RequestIndication	
Syntax:	<pre>void < User >_RequestIndication(uint8 node, NetworkHandleType channel, uint32 requestedPgn, uint8 sourceAddress, uint8 destAddress, uint8 priority)</pre>	
Sync/Async:	Synchronous	
Reentrancy:	Reentrant	
Parameters (in):	node	Node by which the request was received.
	channel	Channel on which the request was received.
	requestedPgn	PGN of the requested PG.
	sourceAddress	Address of the node that sent the Request PG.
	destAddress	Address of this node or 0xFF for broadcast.
	priority	Priority of the Request PG.
Parameters (inout):	None	

Parameters (out):	None
Return value:	None
Description:	Indicates reception of a Request PG.

] (SRS_J1939_00014)

[SWS_J1939Rm_00085] [The configured <User>_RequestIndication function shall be available for each user that has J1939RmUserRequestIndication enabled.] ()

See section 7.4 for details.

8.6.3.2 <User>_AckIndication

[SWS_J1939Rm_00064] [

Service name:	< User >_AckIndication	
Syntax:	<pre>void < User >_AckIndication(uint8 node, NetworkHandleType channel, uint32 ackPgn, J1939Rm_AckCode ackCode, uint8 ackAddress, uint8 sourceAddress, uint8 priority)</pre>	
Sync/Async:	Synchronous	
Reentrancy:	Reentrant	
Parameters (in):	node	Node by which the acknowledgement was received.
	channel	Channel on which the acknowledgement was received.
	ackPgn	Acknowledged PGN.
	ackCode	Type of acknowledgement, see definition of J1939Rm_AckCode for available codes.
	ackAddress	Address of this node.
	sourceAddress	Address of the node that sent the Acknowledgement PG.
	priority	Priority of the Acknowledgement PG.
Parameters (inout):	None	
Parameters (out):	None	
Return value:	None	
Description:	Indicates reception of an Acknowledgement PG.	

] (SRS_J1939_00015)

[SWS_J1939Rm_00086] [The configured <User>_AckIndication function shall be available for each user that has J1939RmUserAckIndication enabled.] ()

See section 7.7 for details.

8.6.3.3 <User>_RequestTimeoutIndication

[SWS_J1939Rm_00065] [

Service name:	< User >_RequestTimeoutIndication	
Syntax:	<pre>void < User >_RequestTimeoutIndication(uint8 node,</pre>	

	NetworkHandleType channel, uint32 requestedPgn, uint8 destAddress)	
Sync/Async:	Synchronous	
Reentrancy:	Reentrant	
Parameters (in):	node	Node by which the request was sent.
	channel	Channel on which the request was sent.
	requestedPgn	PGN of the requested PG.
	destAddress	Address of the destination node or 0xFF for broadcast.
Parameters (inout):	None	
Parameters (out):	None	
Return value:	None	
Description:	Indicates timeout of a request triggered with the same parameters.	

] (SRS_J1939_00026)

[SWS_J1939Rm_00087] [The configured <User>_RequestTimeoutIndication function shall be available for each user that has J1939RmUserTimeoutSupervision enabled.] ()

See section 7.8 for details.

8.7 Service Port Descriptions

This section defines the client server interfaces and the derived service ports used by J1939Rm to communicate with application software components (SWCs).

8.7.1 Provided Service Ports

These service ports provide API functions of the J1939Rm to the application SWCs.

Please note: All three ports use a port defined argument value to provide the userId argument of the corresponding BSW interfaces.

8.7.1.1 J1939Rm_SendAck

[SWS_J1939Rm_00098] [

Name	J1939Rm_SendAck_{user}		
Kind	ProvidedPort	Interface	AppSendAck
Description	--		
Variation	{ecuc(J1939Rm/J1939RmGeneral.J1939RmSupportAckTransmission)} == true user = {ecuc(J1939Rm/J1939RmConfigSet/J1939RmNode/J1939RmUser.SHORT-NAME)}		

] (SRS_J1939_00017)

8.7.1.2 J1939Rm_SendRequest

[SWS_J1939Rm_00097] [

Name	J1939Rm_SendRequest_{user}		
Kind	ProvidedPort	Interface	AppSendRequest
Description	--		
Variation	{ecuc(J1939Rm/J1939RmGeneral.J1939RmSupportRequestTransmission)} == true user = {ecuc(J1939Rm/J1939RmConfigSet/J1939RmNode/J1939RmUser.SHORT-NAME)}		

] (SRS_J1939_00016)

8.7.1.3 J1939Rm_CancelRequestTimeout

[SWS_J1939Rm_00099] [

Name	J1939Rm_CancelRequestTimeout_{user}		
Kind	ProvidedPort	Interface	AppCancelRequestTimeout
Description	--		
Variation	{ecuc(J1939Rm/J1939RmGeneral.J1939RmSupportTimeoutSupervision)} == true user = {ecuc(J1939Rm/J1939RmConfigSet/J1939RmNode/J1939RmUser.SHORT-NAME)}		

] (SRS_J1939_00026)

8.7.2 Required Service Ports

These service ports provide call back functions of the J1939Rm to the application SWCs.

8.7.2.1 J1939Rm_AckIndication

[SWS_J1939Rm_00101] [

Name	J1939Rm_AckIndication_{user}		
Kind	RequiredPort	Interface	AppAckIndication
Description	--		
Variation	{ecuc(J1939Rm/J1939RmGeneral.J1939RmSupportAckIndication)} == true user = {ecuc(J1939Rm/J1939RmConfigSet/J1939RmNode/J1939RmUser.SHORT-NAME)}		

] (SRS_J1939_00015)

8.7.2.2 J1939Rm_RequestIndication

[SWS_J1939Rm_00100] [

Name	J1939Rm_RequestIndication_{user}		
Kind	RequiredPort	Interface	AppRequestIndication

Description	--
Variation	{ecuc(J1939Rm/J1939RmGeneral.J1939RmSupportRequestIndication)} == true user = {ecuc(J1939Rm/J1939RmConfigSet/J1939RmNode/J1939RmUser.SHORT-NAME)}

] (SRS_J1939_00014)

8.7.2.3 J1939Rm_RequestTimeoutIndication

[SWS_J1939Rm_00102] [

Name	J1939Rm_RequestTimeoutIndication_{user}		
Kind	RequiredPort	Interface	AppRequestTimeoutIndication
Description	--		
Variation	{ecuc(J1939Rm/J1939RmGeneral.J1939RmSupportTimeoutSupervision)} == true user = {ecuc(J1939Rm/J1939RmConfigSet/J1939RmNode/J1939RmUser.SHORT-NAME)}		

] (SRS_J1939_00026)

8.7.3 Client-Server Interfaces

This section lists the client-server interfaces used by the ports provided and required by the J1939 Request Manager.

Please note: The availability of these interfaces depends on the configuration of the J1939 Request Manager. The relevant parameters of the J1939 Request Manager configuration are listed as “Variation” of the operations.

8.7.3.1 AppSendAck

[SWS_J1939Rm_00103] [

Name	AppSendAck	
Comment	--	
IsService	true	
Variation	{ecuc(J1939Rm/J1939RmGeneral.J1939RmSupportAckTransmission)} == true	
Possible Errors	0	E_OK
	1	E_NOT_OK

Operations

SendAck	
Comments	Requests transmission of an Acknowledgement PG.
Variation	--

Parameters	channel	
	Comment	Channel on which the acknowledgement shall be sent.
	Type	NetworkHandleType
	Variation	--
	Direction	IN
	ackPgn	
	Comment	Acknowledged PGN.
	Type	uint32
	Variation	--
	Direction	IN
	ackCode	
	Comment	Type of acknowledgement, see definition of J1939Rm_AckCode for available codes.
	Type	J1939Rm_AckCode
	Variation	--
	Direction	IN
	ackAddress	
	Comment	Address of the node that sent the request.
	Type	uint8
	Variation	--
	Direction	IN
	priority	
	Comment	Priority of the Acknowledgement PG.
	Type	uint8
	Variation	--
	Direction	IN
	broadcast	
	Comment	Indicates whether the ACKM is a response to a broadcast request.
	Type	boolean
	Variation	--
	Direction	IN

Possible Errors	E_OK	Operation successful
	E_NOT_OK	--

] (SRS_J1939_00017)

8.7.3.2 AppSendRequest

[SWS_J1939Rm_00104] [

Name	AppSendRequest	
Comment	--	
IsService	true	
Variation	{ecuc(J1939Rm/J1939RmGeneral.J1939RmSupportRequestTransmission)} == true	
Possible Errors	0	E_OK
	1	E_NOT_OK

Operations

SendRequest		
Comments	Requests transmission of a Request PG.	
Variation	--	
Parameters	channel	
	Comment	Channel on which the request shall be sent.
	Type	NetworkHandleType
	Variation	--
	Direction	IN
	requestedPgn	
	Comment	PGN of the requested PG.
	Type	uint32
	Variation	--
	Direction	IN
	destAddress	
	Comment	Address of the destination node or 0xFF for broadcast.
	Type	uint8
	Variation	--
	Direction	IN

	priority	
	Comment	Priority of the Request PG.
	Type	uint8
	Variation	--
	Direction	IN
	checkTimeout	
	Comment	TRUE: Timeout supervision will be performed FALSE: No timeout supervision will be started
	Type	boolean
	Variation	--
	Direction	IN
Possible Errors	E_OK	Operation successful
	E_NOT_OK	--

] (SRS_J1939_00016)

8.7.3.3 AppCancelRequestTimeout

[SWS_J1939Rm_00105] [

Name	AppCancelRequestTimeout	
Comment	--	
IsService	true	
Variation	{ecuc(J1939Rm/J1939RmGeneral.J1939RmSupportTimeoutSupervision)} == true	
Possible Errors	0	E_OK
	1	E_NOT_OK

Operations

CancelRequestTimeout		
Comments	Cancels timeout monitoring of a Request. If the request is not active, or timeout monitoring was not requested, this call has no effect.	
Variation	--	
Parameters	channel	
	Comment	Channel on which the request was sent.
	Type	NetworkHandleType
	Variation	--

	Direction	IN
	requestedPgn	
	Comment	PGN of the requested PG.
	Type	uint32
	Variation	--
	Direction	IN
	destAddress	
	Comment	Address of the destination node or 0xFF for broadcast.
	Type	uint8
	Variation	--
	Direction	IN
Possible Errors	E_OK	Operation successful
	E_NOT_OK	--

] (SRS_J1939_00026)

8.7.3.4 AppAckIndication

[SWS_J1939Rm_00106] [

Name	AppAckIndication	
Comment	--	
IsService	true	
Variation	{ecuc(J1939Rm/J1939RmGeneral.J1939RmSupportAckIndication)} == true	
Possible Errors	0	E_OK
	1	E_NOT_OK

Operations

AckIndication		
Comments	Indicates reception of an Acknowledgement PG.	
Variation	--	
Parameters	node	
	Comment	Node by which the acknowledgement was received.
	Type	uint8

	Variation	--
	Direction	IN
	channel	
	Comment	Channel on which the acknowledgement was received.
	Type	NetworkHandleType
	Variation	--
	Direction	IN
	ackPgn	
	Comment	Acknowledged PGN.
	Type	uint32
	Variation	--
	Direction	IN
	ackCode	
	Comment	Type of acknowledgement, see definition of J1939Rm_AckCode for available codes.
	Type	J1939Rm_AckCode
	Variation	--
	Direction	IN
	ackAddress	
	Comment	Address of this node.
	Type	uint8
	Variation	--
	Direction	IN
	sourceAddress	
	Comment	Address of the node that sent the Acknowledgement PG.
	Type	uint8
	Variation	--
	Direction	IN
	priority	
	Comment	Priority of the Acknowledgement PG.
	Type	uint8

	Variation	--
	Direction	IN
Possible Errors	E_OK	Operation successful
	E_NOT_OK	--

] (SRS_J1939_00015)

8.7.3.5 AppRequestIndication

[SWS_J1939Rm_00107] [

Name	AppRequestIndication	
Comment	--	
IsService	true	
Variation	{ecuc(J1939Rm/J1939RmGeneral.J1939RmSupportRequestIndication)} == true	
Possible Errors	0	E_OK
	1	E_NOT_OK

Operations

RequestIndication		
Comments	Indicates reception of a Request PG.	
Variation	--	
Parameters	node	
	Comment	Node by which the request was received.
	Type	uint8
	Variation	--
	Direction	IN
	channel	
	Comment	Channel on which the request was received.
	Type	NetworkHandleType
	Variation	--
	Direction	IN
	requestedPgn	
	Comment	PGN of the requested PG.
Type	uint32	

	Variation	--
	Direction	IN
	sourceAddress	
	Comment	Address of the node that sent the Request PG.
	Type	uint8
	Variation	--
	Direction	IN
	destAddress	
	Comment	Address of this node or 0xFF for broadcast.
	Type	uint8
	Variation	--
	Direction	IN
	priority	
	Comment	Priority of the Request PG.
	Type	uint8
	Variation	--
Direction	IN	
Possible Errors	E_OK	Operation successful
	E_NOT_OK	--

] (SRS_J1939_00014)

8.7.3.6 AppRequestTimeoutIndication

[SWS_J1939Rm_00108] [

Name	AppRequestTimeoutIndication	
Comment	--	
IsService	true	
Variation	{ecuc(J1939Rm/J1939RmGeneral.J1939RmSupportTimeoutSupervision)} == true	
Possible Errors	0	E_OK
	1	E_NOT_OK

Operations

RequestTimeoutIndication

Comments	Indicates timeout of a request triggered with the same parameters.	
Variation	--	
Parameters	node	
	Comment	Node by which the request was sent.
	Type	uint8
	Variation	--
	Direction	IN
	channel	
	Comment	Channel on which the request was sent.
	Type	NetworkHandleType
	Variation	--
	Direction	IN
	requestedPgn	
	Comment	PGN of the requested PG.
	Type	uint32
	Variation	--
	Direction	IN
	destAddress	
	Comment	Address of the destination node or 0xFF for broadcast.
	Type	uint8
	Variation	--
	Direction	IN
Possible Errors	E_OK	Operation successful
	E_NOT_OK	--

J (SRS_J1939_00026)

8.7.4 Implementation Data Types

In this section, the implementation data types used by the client-server interfaces of the J1939 Request Manager are listed.

Please note: It is essential that the implementation of the J1939 Request Manager does not define these data types twice, by including them both from the RTE generated header and the own types header.

8.7.4.1 J1939Rm_AckCode

[SWS_J1939Rm_00109] [

Name	J1939Rm_AckCode		
Kind	Enumeration		
Range	J1939RM_ACK_POSITIVE	0	Positive Acknowledgement (0)
	J1939RM_ACK_NEGATIVE	1	Negative Acknowledgement (1)
	J1939RM_ACK_ACCESS_DENIED	2	Access Denied (2)
	J1939RM_ACK_CANNOT_RESPOND	3	Cannot Respond (3)
Description	This type represents the available kinds of acknowledgements.		
Variation	--		

] ()

9 Sequence diagrams

The following sequence diagrams shall give an impression of the way the J1939 Request Manager shall behave and interoperate with other BSW modules. They are not complete and not binding for the implementation.

9.1 Reception of Request PG

The following diagram shows the interaction with PduR and a J1939Rm User when a Request PG is received.

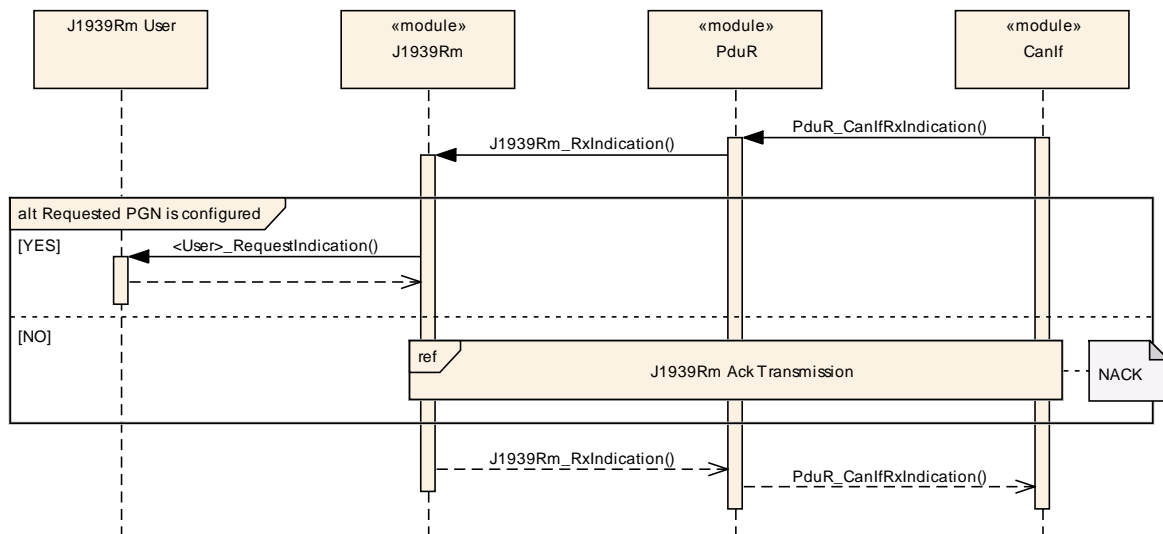

Figure 2: Reception of Request PG

9.2 Transmission of Acknowledgement PG

The following diagram shows the interaction with a J1939Rm User and PduR when an Acknowledgement PG is transmitted.

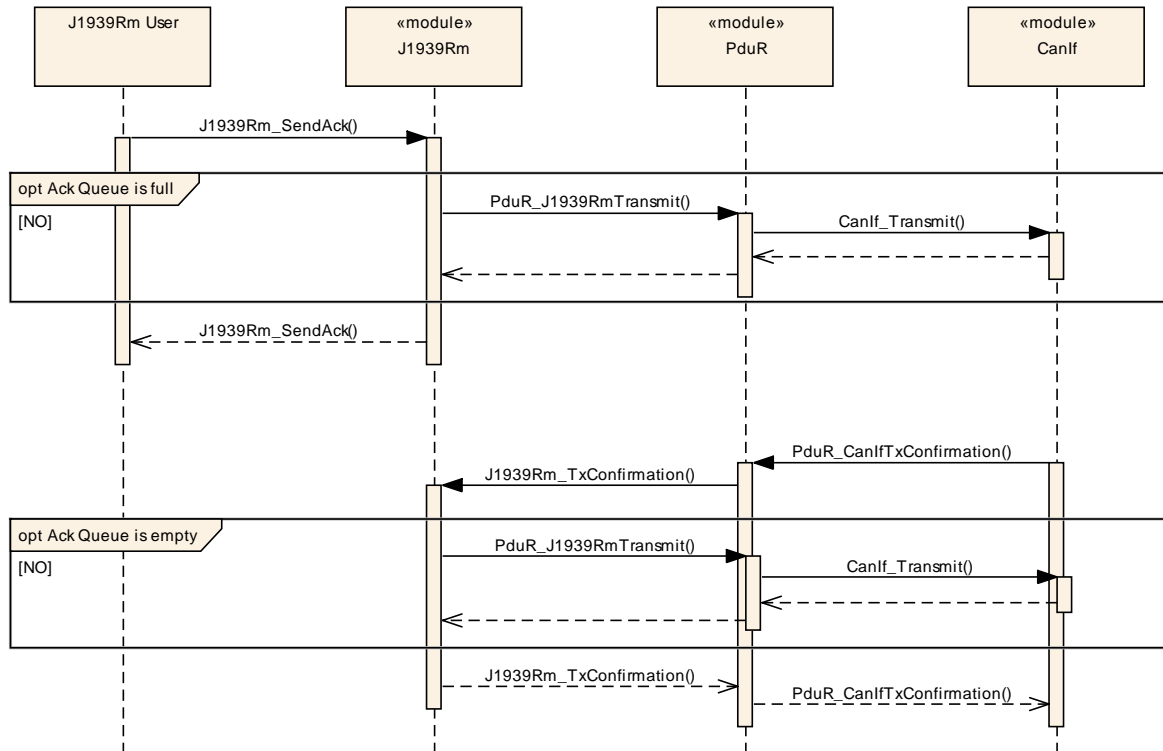

Figure 3: Transmission of Acknowledgement PG

9.3 Handling of Request for a COM Pdu

The following diagram shows the interaction with PduR and COM when the J1939 Request Manager receives a Request for a PG of PDU1 format that is transmitted as COM Pdu.

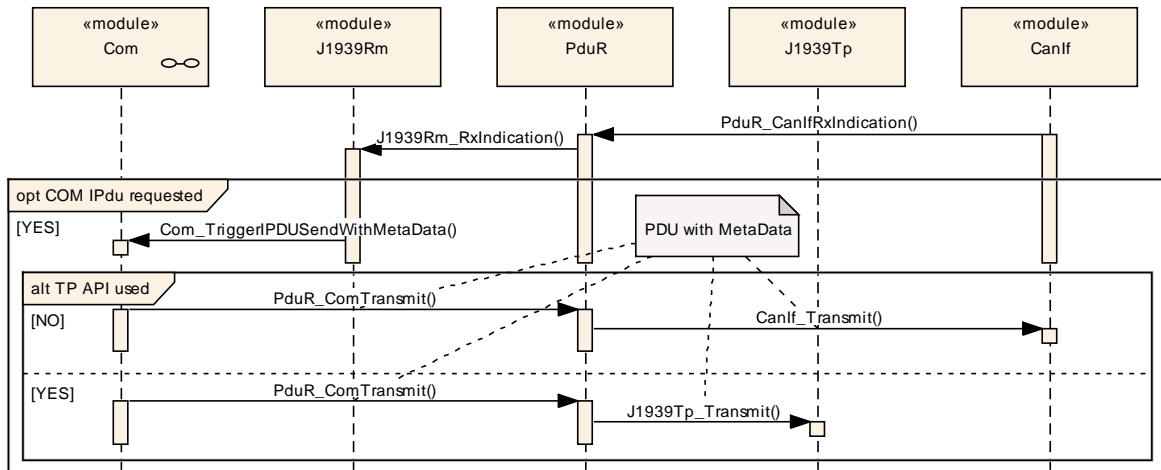

Figure 4: Handling of Request for a COM Pdu with PDU1 format

9.4 Handling of Request for a Diagnostic Pdu

The following diagram shows the interaction with PduR and J1939Dcm when a Request for a diagnostic PG is received.

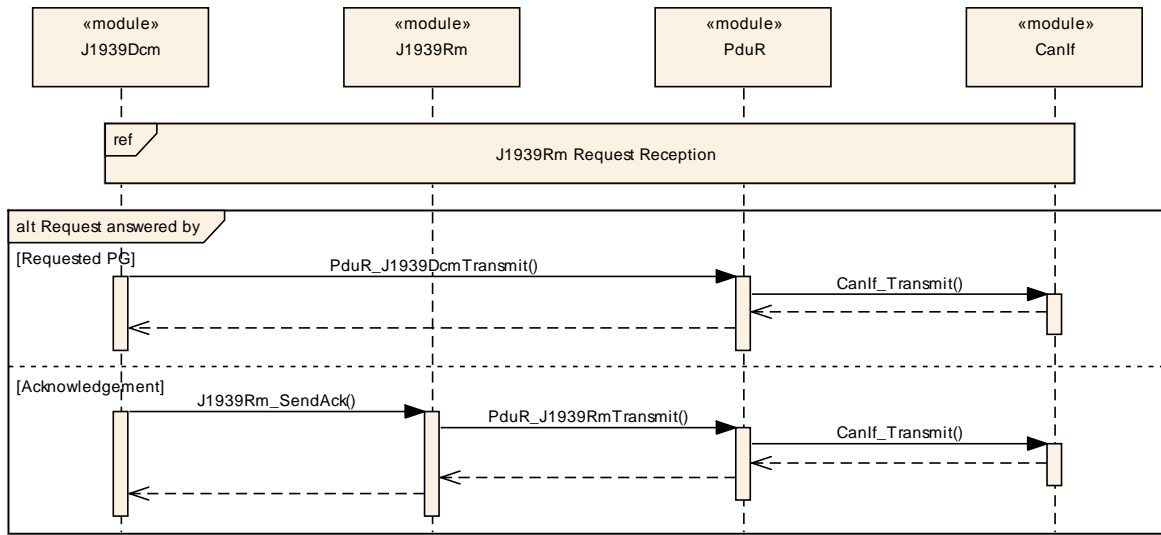

Figure 5: Handling of Request for a Diagnostic Pdu

9.5 Transmission of Request PG

The following diagram shows the interaction with a J1939Rm User and PduR when a Request PG is transmitted.

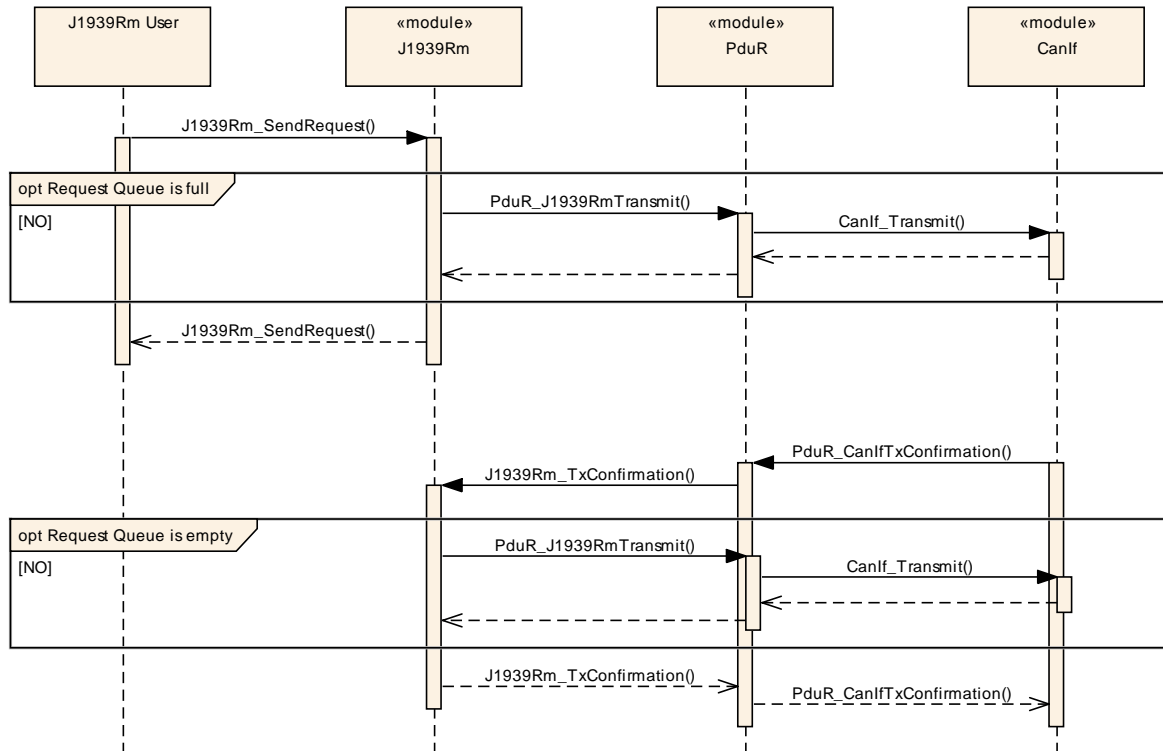

Figure 6: Transmission of Request PG

9.6 Reception of Acknowledgement PG

The following diagram shows the interaction with PduR and a J1939Rm User when an Acknowledgement PG is received.

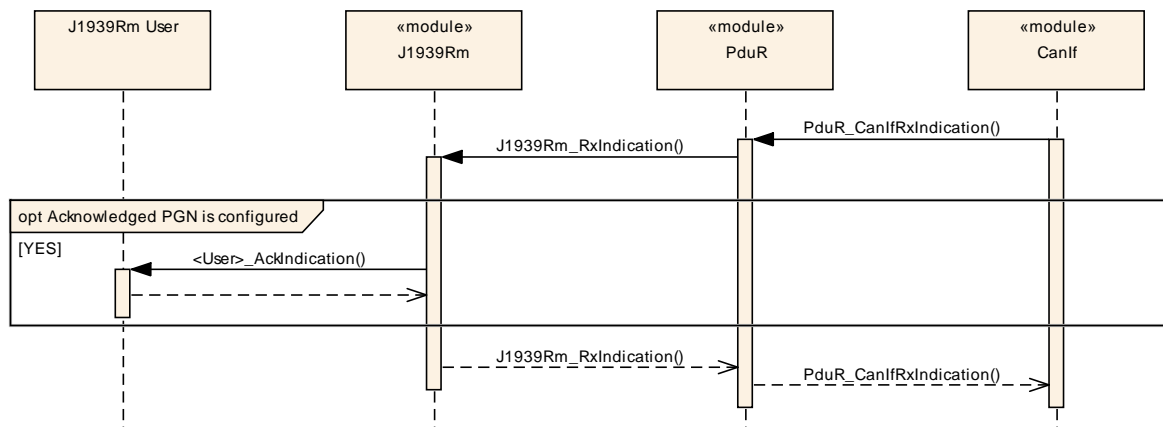

Figure 7: Reception of Acknowledgement PG

9.7 Monitoring of Request Timeout

The following diagram shows the interaction with a J1939Rm User and PduR when the J1939Rm monitors timeout of a transmitted Request PG.

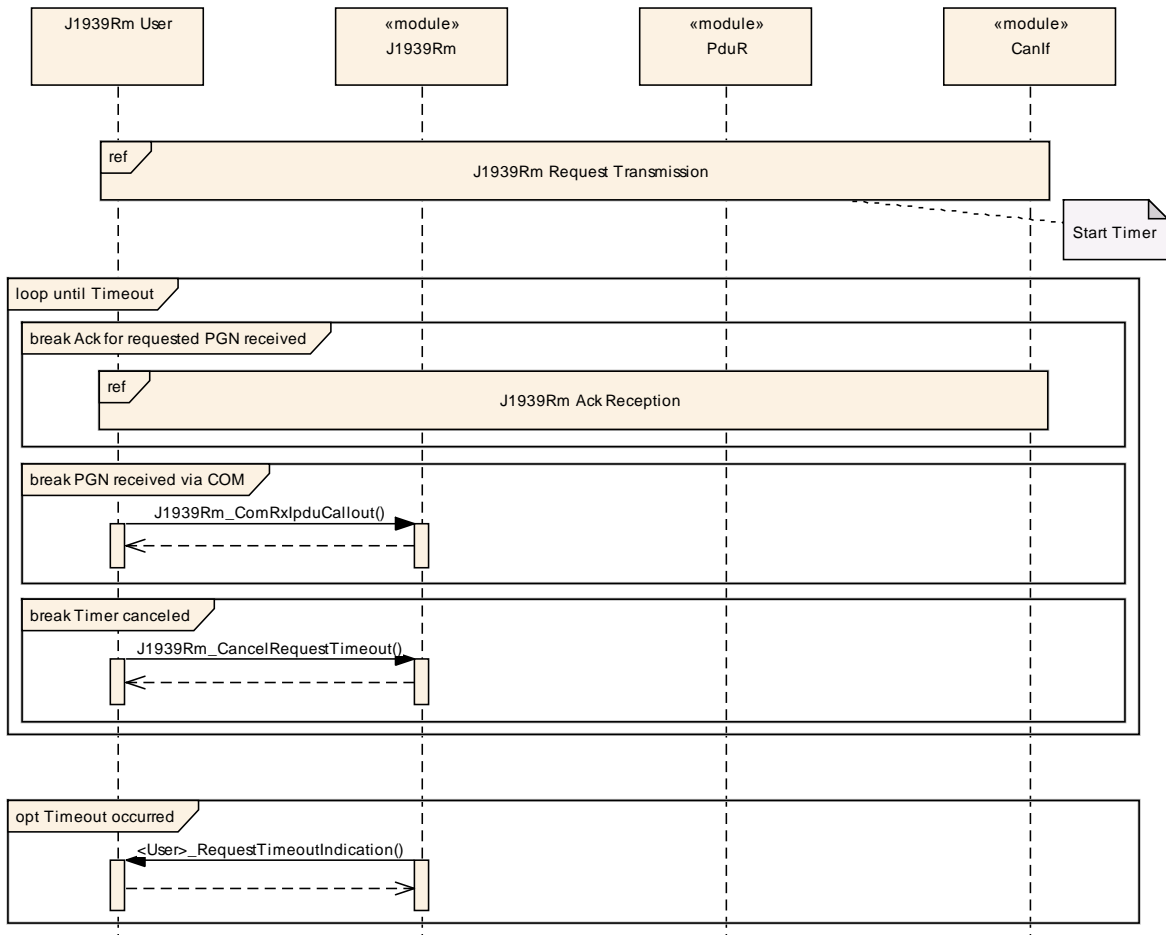

Figure 8: Monitoring of Request Timeout

10 Configuration specification

In general, this chapter defines configuration parameters and their clustering into containers. In order to support the specification section 10.1 describes fundamentals. It also specifies a template (table) you shall use for the parameter specification. We intend to leave section 10.1 in the specification to guarantee comprehension.

Section 10.2 specifies the structure (containers) and the parameters of the J1939 Request Manager.

Section 10.3 specifies published information of the J1939 Request Manager.

10.1 How to read this chapter

For details, refer to the chapter 10.1 “Introduction to configuration specification” in the SWS BSW General [4].

10.2 Containers and configuration parameters

The following sections summarize all configuration parameters of the J1939 Request Manager. The detailed meaning of the parameters is described in chapters 7 and 8.

The following pictures show an overview of the configuration parameters available for J1939Rm:

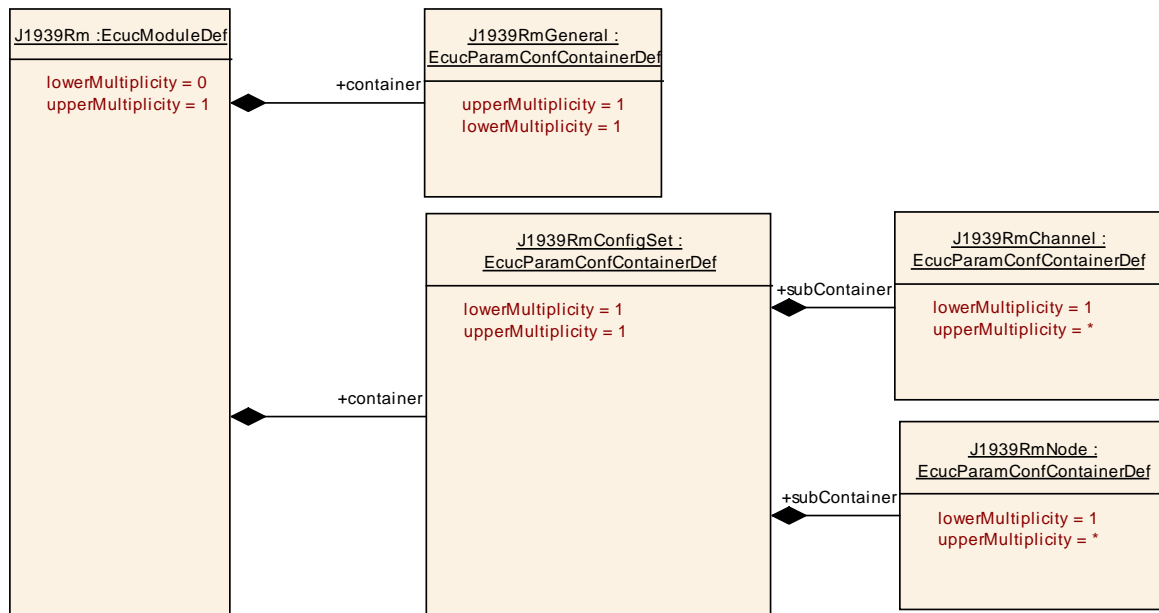

Figure 9: Configuration container J1939Rm with subcontainer J1939RmConfigSet

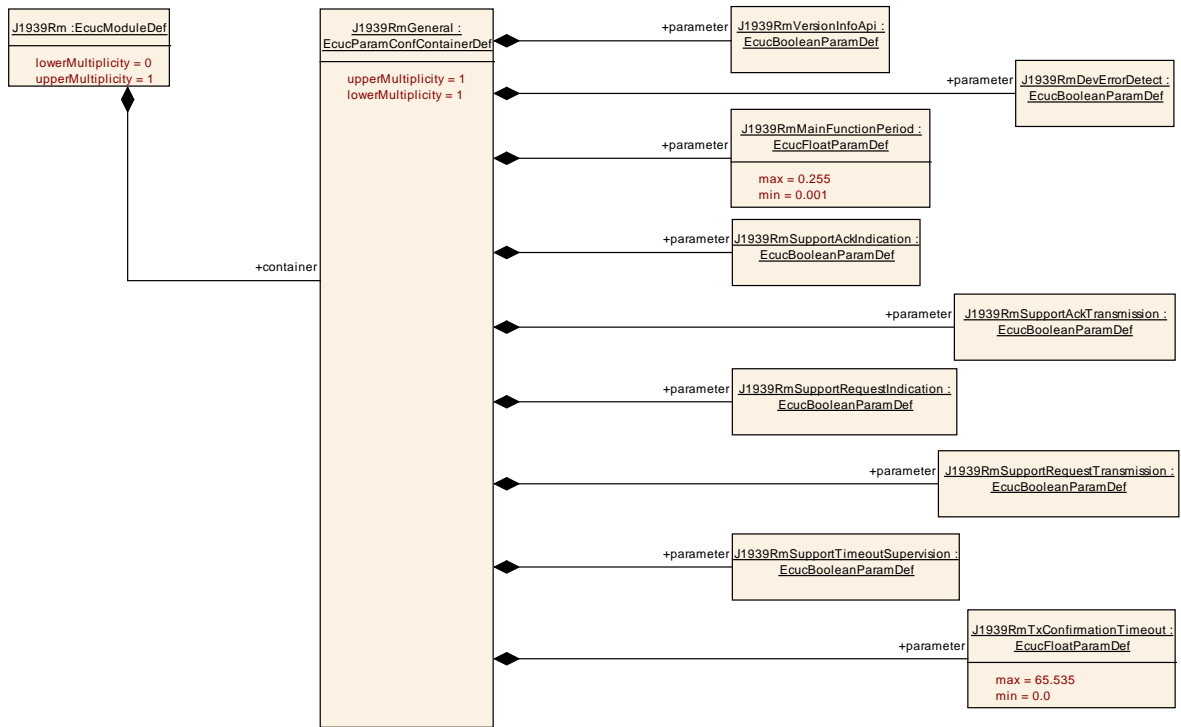

Figure 10: Configuration container J1939RmGeneral

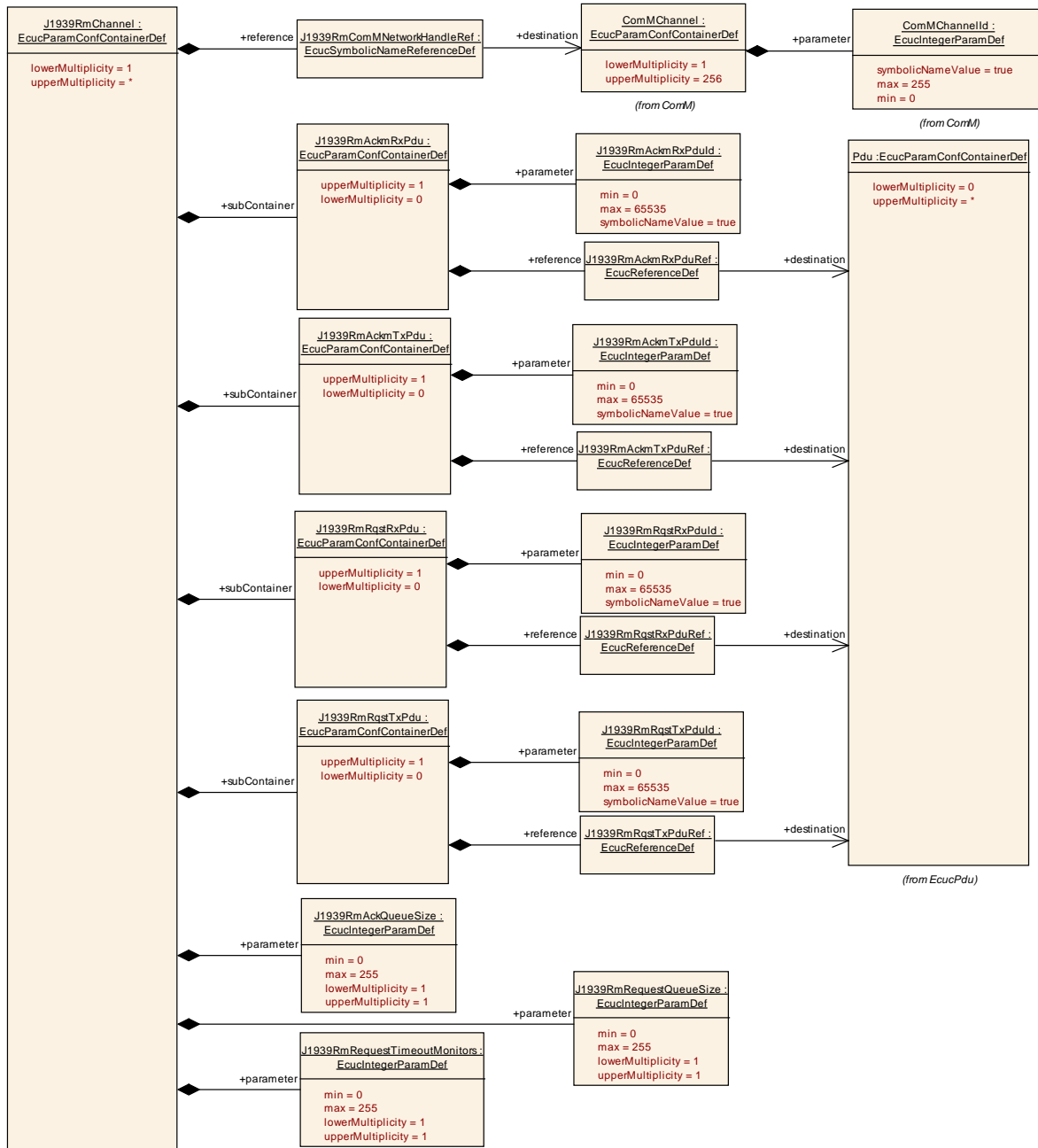

Figure 11: Configuration container J1939RmChannel

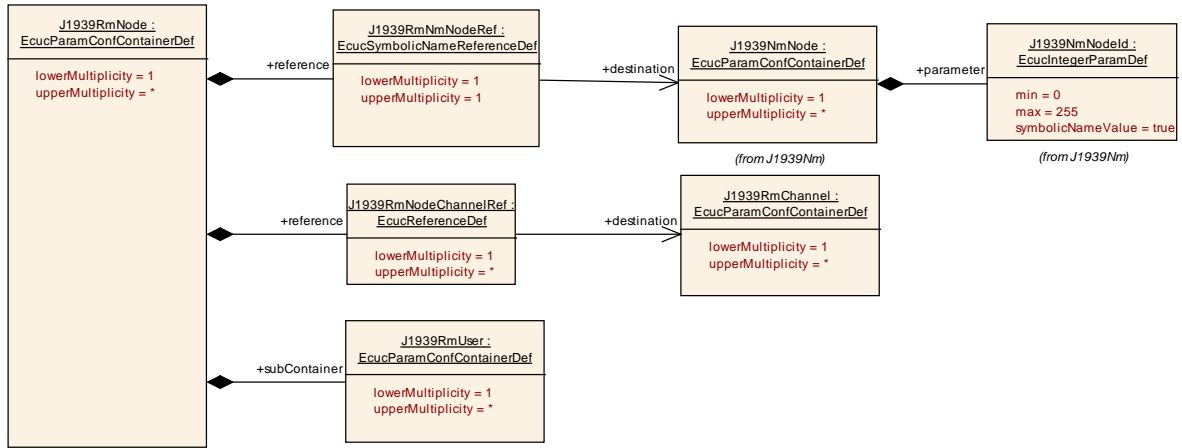

Figure 12: Configuration container J1939RmNode

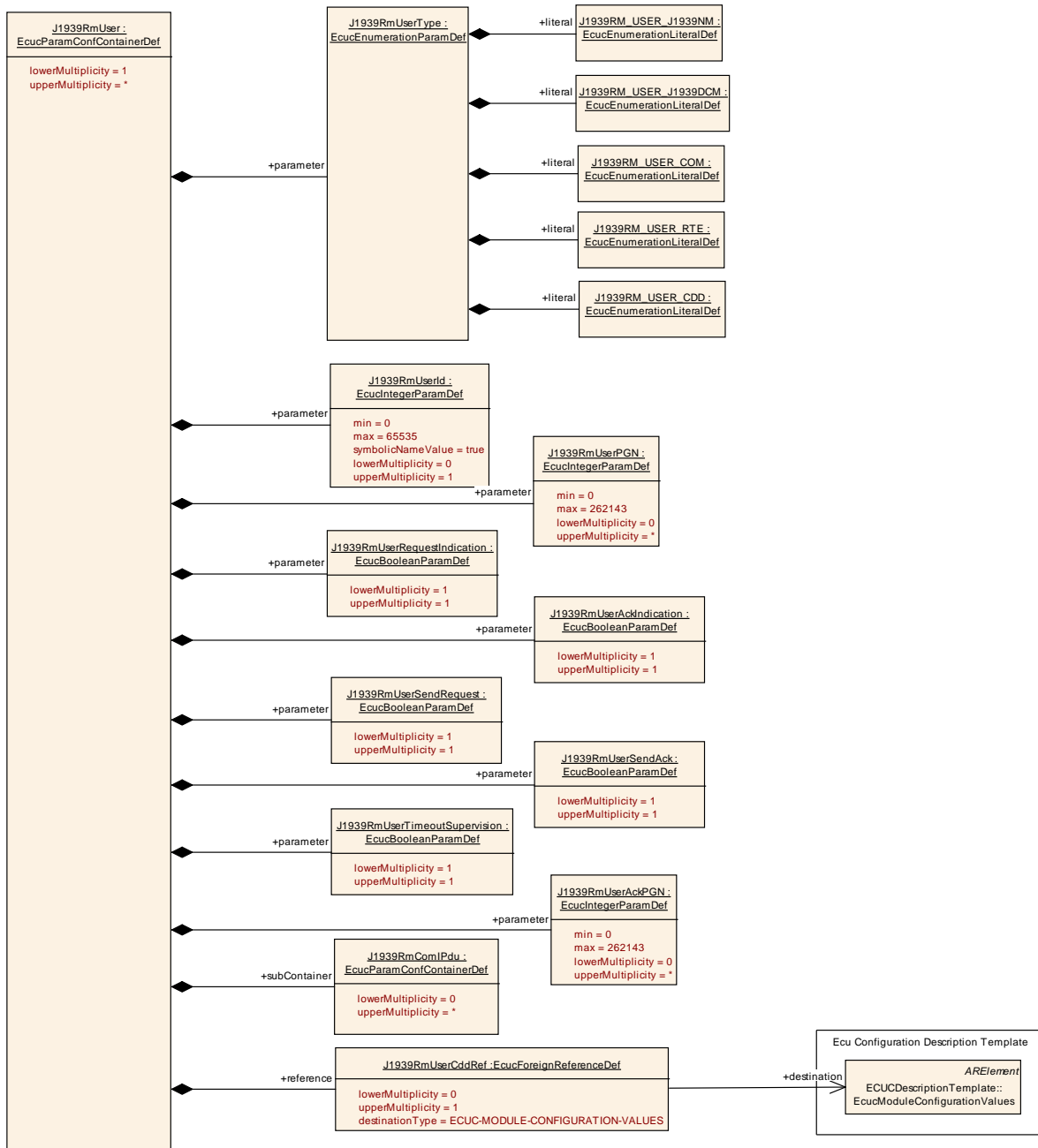

Figure 13: Configuration container J1939RmUser

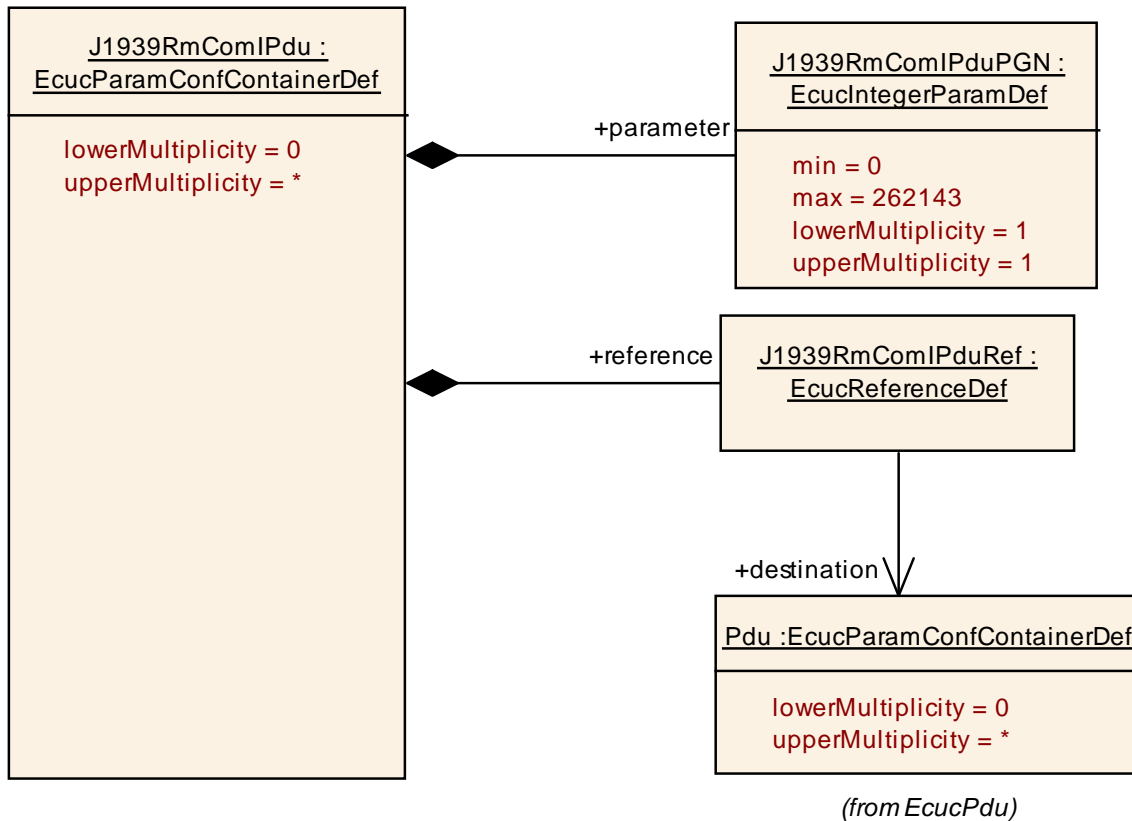

Figure 14: Configuration container J1939RmComIPdu

10.2.1 Variants

[SWS_J1939Rm_00046] [The J1939 Request Manager shall support the configuration variants VARIANT-PRE-COMPILE, VARIANT-LINK-TIME, and VARIANT-POST-BUILD.] ()

10.2.2 J1939Rm

SWS Item	ECUC_J1939Rm_00043 :
Module Name	J1939Rm
Module Description	Configuration of the J1939 Request Manager.
Post-Build Variant Support	true

Included Containers		
Container Name	Multiplicity	Scope / Dependency
J1939RmConfigSet	1	This container contains the configuration parameters and sub containers of the AUTOSAR J1939Rm module.
J1939RmGeneral	1	Contains the general configuration parameters of the module.

10.2.3 J1939RmGeneral

SWS Item	ECUC_J1939Rm_00001 :
Container Name	J1939RmGeneral
Description	Contains the general configuration parameters of the module.
Configuration Parameters	

SWS Item	ECUC_J1939Rm_00003 :		
Name	J1939RmDevErrorDetect		
Description	Switches the Default Error Tracer (Det) detection and notification ON or OFF. <ul style="list-style-type: none"> • true: enabled (ON). • false: disabled (OFF). 		
Multiplicity	1		
Type	EcucBooleanParamDef		
Default value	--		
Post-Build Variant Value	false		
Value Configuration Class	Pre-compile time	X	All Variants
	Link time	--	
	Post-build time	--	
Scope / Dependency	scope: local		

SWS Item	ECUC_J1939Rm_00004 :		
Name	J1939RmMainFunctionPeriod		
Description	Execution cycle of J1939Rm_MainFunction in seconds.		
Multiplicity	1		
Type	EcucFloatParamDef		
Range	0.001 .. 0.255		
Default value	--		
Post-Build Variant Value	false		
Value Configuration Class	Pre-compile time	X	VARIANT-PRE-COMPILE
	Link time	X	VARIANT-LINK-TIME, VARIANT-POST-BUILD
	Post-build time	--	
Scope / Dependency	scope: ECU		

SWS Item	ECUC_J1939Rm_00054 :		
Name	J1939RmSupportAckIndication		
Description	Pre-processor switch for enabling support of acknowledgement indications.		
Multiplicity	1		
Type	EcucBooleanParamDef		
Default value	--		
Post-Build Variant Value	false		
Value Configuration Class	Pre-compile time	X	All Variants
	Link time	--	
	Post-build time	--	
Scope / Dependency	scope: local		

SWS Item	ECUC_J1939Rm_00055 :		
Name	J1939RmSupportAckTransmission		
Description	Pre-processor switch for enabling support of acknowledgement transmission.		
Multiplicity	1		

Type	EcucBooleanParamDef		
Default value	--		
Post-Build Variant Value	false		
Value Configuration Class	Pre-compile time	X	All Variants
	Link time	--	
	Post-build time	--	
Scope / Dependency	scope: local		

SWS Item	ECUC_J1939Rm_00056 :		
Name	J1939RmSupportRequestIndication		
Description	Pre-processor switch for enabling support of request indications.		
Multiplicity	1		
Type	EcucBooleanParamDef		
Default value	--		
Post-Build Variant Value	false		
Value Configuration Class	Pre-compile time	X	All Variants
	Link time	--	
	Post-build time	--	
Scope / Dependency	scope: local		

SWS Item	ECUC_J1939Rm_00057 :		
Name	J1939RmSupportRequestTransmission		
Description	Pre-processor switch for enabling support of request transmission.		
Multiplicity	1		
Type	EcucBooleanParamDef		
Default value	--		
Post-Build Variant Value	false		
Value Configuration Class	Pre-compile time	X	All Variants
	Link time	--	
	Post-build time	--	
Scope / Dependency	scope: local		

SWS Item	ECUC_J1939Rm_00058 :		
Name	J1939RmSupportTimeoutSupervision		
Description	Pre-processor switch for enabling support of request timeout supervision.		
Multiplicity	1		
Type	EcucBooleanParamDef		
Default value	--		
Post-Build Variant Value	false		
Value Configuration Class	Pre-compile time	X	All Variants
	Link time	--	
	Post-build time	--	
Scope / Dependency	scope: local		

SWS Item	ECUC_J1939Rm_00059 :		
Name	J1939RmTxConfirmationTimeout		
Description	Time in seconds to wait for a confirmation after transmission of a message. The behaviour when the time elapses depends on the transmitted message.		
Multiplicity	1		
Type	EcucFloatParamDef		
Range	0 .. 65.535		
Default value	--		
Post-Build Variant Value	false		
Value Configuration Class	Pre-compile time	X	VARIANT-PRE-COMPILE
	Link time	X	VARIANT-LINK-TIME, VARIANT-POST-

			BUILD
	Post-build time	--	
Scope / Dependency	scope: local		

SWS Item	ECUC_J1939Rm_00002 :		
Name	J1939RmVersionInfoApi		
Description	Pre-processor switch for enabling version info API support.		
Multiplicity	1		
Type	EcucBooleanParamDef		
Default value	--		
Post-Build Variant Value	false		
Value Configuration Class	Pre-compile time	X	All Variants
	Link time	--	
	Post-build time	--	
Scope / Dependency	scope: local		

No Included Containers

10.2.4 J1939RmConfigSet

SWS Item	ECUC_J1939Rm_00017 :		
Container Name	J1939RmConfigSet		
Description	This container contains the configuration parameters and sub containers of the AUTOSAR J1939Rm module.		
Configuration Parameters			

Included Containers			
Container Name	Multiplicity	Scope / Dependency	
J1939RmChannel	1..*	Contains the parameters for a CAN channel supported by the J1939 Request Manager.	
J1939RmNode	1..*	Contains the parameters for the support of a logical J1939 node (identified by an ECU address).	

10.2.5 J1939RmChannel

SWS Item	ECUC_J1939Rm_00009 :		
Container Name	J1939RmChannel		
Description	Contains the parameters for a CAN channel supported by the J1939 Request Manager.		
Post-Build Variant Multiplicity	true		
Multiplicity Configuration Class	Pre-compile time	X	VARIANT-PRE-COMPILE
	Link time	X	VARIANT-LINK-TIME
	Post-build time	X	VARIANT-POST-BUILD
Configuration Parameters			

SWS Item	ECUC_J1939Rm_00007 :		
Name	J1939RmAckQueueSize		
Description	Number of transmitted acknowledgements that can be stored.		
Multiplicity	1		

Type	EcucIntegerParamDef		
Range	0 .. 255		
Default value	--		
Post-Build Variant Value	false		
Value Configuration Class	Pre-compile time	X	VARIANT-PRE-COMPILE
	Link time	X	VARIANT-LINK-TIME, VARIANT-POST-BUILD
	Post-build time	--	
Scope / Dependency	scope: local		

SWS Item	ECUC_J1939Rm_00006 :		
Name	J1939RmRequestQueueSize		
Description	Number of transmitted requests that can be stored.		
Multiplicity	1		
Type	EcucIntegerParamDef		
Range	0 .. 255		
Default value	--		
Post-Build Variant Value	false		
Value Configuration Class	Pre-compile time	X	VARIANT-PRE-COMPILE
	Link time	X	VARIANT-LINK-TIME, VARIANT-POST-BUILD
	Post-build time	--	
Scope / Dependency	scope: local		

SWS Item	ECUC_J1939Rm_00008 :		
Name	J1939RmRequestTimeoutMonitors		
Description	Number of transmitted requests that can be monitored for timeout.		
Multiplicity	1		
Type	EcucIntegerParamDef		
Range	0 .. 255		
Default value	--		
Post-Build Variant Value	false		
Value Configuration Class	Pre-compile time	X	VARIANT-PRE-COMPILE
	Link time	X	VARIANT-LINK-TIME, VARIANT-POST-BUILD
	Post-build time	--	
Scope / Dependency	scope: local		

SWS Item	ECUC_J1939Rm_00051 :		
Name	J1939RmComMNetworkHandleRef		
Description	Reference to the channel defined by the ComMChannel providing access to the unique channel index ComMChannelId.		
Multiplicity	1		
Type	Symbolic name reference to [ComMChannel]		
Post-Build Variant Value	false		
Value Configuration Class	Pre-compile time	X	VARIANT-PRE-COMPILE
	Link time	X	VARIANT-LINK-TIME, VARIANT-POST-BUILD
	Post-build time	--	
Scope / Dependency	scope: local		

Included Containers		
Container Name	Multiplicity	Scope / Dependency
J1939RmAckmRxPdu	0..1	Contains the configuration of the I-PDU used to receive the Acknowledgement PG.
J1939RmAckmTxPdu	0..1	Contains the configuration of the I-PDU used to transmit the

		Acknowledgement PG.
J1939RmRqstRxPdu	0..1	Contains the configuration of the I-PDU used to receive the Request PG.
J1939RmRqstTxPdu	0..1	Contains the configuration of the I-PDU used to transmit the Request PG.

10.2.6 J1939RmAckmRxPdu

SWS Item	ECUC_J1939Rm_00011 :		
Container Name	J1939RmAckmRxPdu		
Description	Contains the configuration of the I-PDU used to receive the Acknowledgement PG.		
Configuration Parameters			

SWS Item	ECUC_J1939Rm_00015 :		
Name	J1939RmAckmRxPduld		
Description	The I-PDU identifier used for RxIndication from PduR.		
Multiplicity	1		
Type	EcucIntegerParamDef (Symbolic Name generated for this parameter)		
Range	0 .. 65535		
Default value	--		
Post-Build Variant Value	false		
Value Configuration Class	Pre-compile time	X	All Variants
	Link time	--	
	Post-build time	--	
Scope / Dependency	scope: ECU		

SWS Item	ECUC_J1939Rm_00016 :		
Name	J1939RmAckmRxPduRef		
Description	Reference to the Pdu object representing the I-PDU.		
Multiplicity	1		
Type	Reference to [Pdu]		
Post-Build Variant Value	false		
Value Configuration Class	Pre-compile time	X	VARIANT-PRE-COMPILE
	Link time	X	VARIANT-LINK-TIME, VARIANT-POST-BUILD
	Post-build time	--	
Scope / Dependency	scope: local		

No Included Containers

10.2.7 J1939RmAckmTxPdu

SWS Item	ECUC_J1939Rm_00012 :		
Container Name	J1939RmAckmTxPdu		
Description	Contains the configuration of the I-PDU used to transmit the Acknowledgement PG.		
Configuration Parameters			

SWS Item	ECUC_J1939Rm_00018 :		
-----------------	-----------------------------	--	--

Name	J1939RmAckmTxPduId		
Description	The I-PDU identifier used for TxConfirmation from PduR.		
Multiplicity	1		
Type	EcucIntegerParamDef (Symbolic Name generated for this parameter)		
Range	0 .. 65535		
Default value	--		
Post-Build Variant Value	false		
Value Configuration Class	Pre-compile time	X	All Variants
	Link time	--	
	Post-build time	--	
Scope / Dependency	scope: ECU		

SWS Item	ECUC_J1939Rm_00019 :		
Name	J1939RmAckmTxPduRef		
Description	Reference to the Pdu object representing the I-PDU.		
Multiplicity	1		
Type	Reference to [Pdu]		
Post-Build Variant Value	false		
Value Configuration Class	Pre-compile time	X	VARIANT-PRE-COMPILE
	Link time	X	VARIANT-LINK-TIME, VARIANT-POST-BUILD
	Post-build time	--	
Scope / Dependency	scope: local		

No Included Containers

10.2.8 J1939RmRqstRxPdu

SWS Item	ECUC_J1939Rm_00013 :		
Container Name	J1939RmRqstRxPdu		
Description	Contains the configuration of the I-PDU used to receive the Request PG.		
Configuration Parameters			

SWS Item	ECUC_J1939Rm_00020 :		
Name	J1939RmRqstRxPduId		
Description	The I-PDU identifier used for RxIndication from PduR.		
Multiplicity	1		
Type	EcucIntegerParamDef (Symbolic Name generated for this parameter)		
Range	0 .. 65535		
Default value	--		
Post-Build Variant Value	false		
Value Configuration Class	Pre-compile time	X	All Variants
	Link time	--	
	Post-build time	--	
Scope / Dependency	scope: ECU		

SWS Item	ECUC_J1939Rm_00021 :		
Name	J1939RmRqstRxPduRef		
Description	Reference to the Pdu object representing the I-PDU.		
Multiplicity	1		
Type	Reference to [Pdu]		
Post-Build Variant Value	false		
Value Configuration Class	Pre-compile time	X	VARIANT-PRE-COMPILE

	Link time	X	VARIANT-LINK-TIME, VARIANT-POST-BUILD
	Post-build time	--	
Scope / Dependency	scope: local		

No Included Containers

10.2.9 J1939RmRqstTxPdu

SWS Item	ECUC_J1939Rm_00014 :		
Container Name	J1939RmRqstTxPdu		
Description	Contains the configuration of the I-PDU used to transmit the Request PG.		
Configuration Parameters			

SWS Item	ECUC_J1939Rm_00022 :		
Name	J1939RmRqstTxPduld		
Description	The I-PDU identifier used for TxConfirmation from PduR.		
Multiplicity	1		
Type	EcucIntegerParamDef (Symbolic Name generated for this parameter)		
Range	0 .. 65535		
Default value	--		
Post-Build Variant Value	false		
Value Configuration Class	Pre-compile time	X	All Variants
	Link time	--	
	Post-build time	--	
Scope / Dependency	scope: ECU		

SWS Item	ECUC_J1939Rm_00023 :		
Name	J1939RmRqstTxPduRef		
Description	Reference to the Pdu object representing the I-PDU.		
Multiplicity	1		
Type	Reference to [Pdu]		
Post-Build Variant Value	false		
Value Configuration Class	Pre-compile time	X	VARIANT-PRE-COMPILE
	Link time	X	VARIANT-LINK-TIME, VARIANT-POST-BUILD
	Post-build time	--	
Scope / Dependency	scope: local		

No Included Containers

10.2.10 J1939RmNode

SWS Item	ECUC_J1939Rm_00049 :		
Container Name	J1939RmNode		
Description	Contains the parameters for the support of a logical J1939 node (identified by an ECU address).		
Post-Build Variant Multiplicity	true		
Multiplicity Configuration	Pre-compile time	X	VARIANT-PRE-COMPILE

Class	Link time	X	VARIANT-LINK-TIME
	Post-build time	X	VARIANT-POST-BUILD
Configuration Parameters			

SWS Item	ECUC_J1939Rm_00005 :		
Name	J1939RmNmNodeRef		
Description	Reference to the corresponding J1939Nm node.		
Multiplicity	1		
Type	Symbolic name reference to [J1939NmNode]		
Post-Build Variant Value	false		
Value Configuration Class	Pre-compile time	X	VARIANT-PRE-COMPILE
	Link time	X	VARIANT-LINK-TIME, VARIANT-POST-BUILD
	Post-build time	--	
Scope / Dependency	scope: local		

SWS Item	ECUC_J1939Rm_00052 :		
Name	J1939RmNodeChannelRef		
Description	Reference to the channels this node has access to.		
Multiplicity	1..*		
Type	Reference to [J1939RmChannel]		
Post-Build Variant Multiplicity	false		
Post-Build Variant Value	false		
Multiplicity Configuration Class	Pre-compile time	X	VARIANT-PRE-COMPILE
	Link time	X	VARIANT-LINK-TIME, VARIANT-POST-BUILD
	Post-build time	--	
Value Configuration Class	Pre-compile time	X	VARIANT-PRE-COMPILE
	Link time	X	VARIANT-LINK-TIME, VARIANT-POST-BUILD
	Post-build time	--	
Scope / Dependency	scope: local		

Included Containers		
Container Name	Multiplicity	Scope / Dependency
J1939RmUser	1..*	Contains the configuration of a module that uses the request and acknowledgement interfaces of J1939Rm.

10.2.11 J1939RmUser

SWS Item	ECUC_J1939Rm_00010 :		
Container Name	J1939RmUser		
Description	Contains the configuration of a module that uses the request and acknowledgement interfaces of J1939Rm.		
Post-Build Variant Multiplicity	true		
Multiplicity Configuration Class	Pre-compile time	X	VARIANT-PRE-COMPILE
	Link time	X	VARIANT-LINK-TIME
	Post-build time	X	VARIANT-POST-BUILD
Configuration Parameters			

SWS Item	ECUC_J1939Rm_00028 :		
-----------------	-----------------------------	--	--

Name	J1939RmUserAckIndication		
Description	Enable AckIndication for this module. In case of CDD, the name is <apiServicePrefix>_AckIndication. In case of RTE, the operation AckIndication of the required port J1939Rm_AckIndication_{user} is called. This parameter shall not be set for J1939RmUserType J1939RM_USER_J1939NM, J1939RM_USER_J1939DCM, or J1939RM_USER_COM.		
Multiplicity	1		
Type	EcucBooleanParamDef		
Default value	--		
Post-Build Variant Value	false		
Value Configuration Class	Pre-compile time	X	All Variants
	Link time	--	
	Post-build time	--	
Scope / Dependency	scope: local		

SWS Item	ECUC_J1939Rm_00061 :		
Name	J1939RmUserAckPGN		
Description	PGN supported to be acknowledged to this module. The PGNs supported by different modules should usually be disjunctive. This parameter shall not be set for J1939RmUserType J1939RM_USER_J1939NM, J1939RM_USER_J1939DCM, and J1939RM_USER_COM.		
Multiplicity	0..*		
Type	EcucIntegerParamDef		
Range	0 .. 262143		
Default value	--		
Post-Build Variant Multiplicity	true		
Post-Build Variant Value	true		
Multiplicity Configuration Class	Pre-compile time	X	VARIANT-PRE-COMPILE
	Link time	X	VARIANT-LINK-TIME
	Post-build time	X	VARIANT-POST-BUILD
Value Configuration Class	Pre-compile time	X	VARIANT-PRE-COMPILE
	Link time	X	VARIANT-LINK-TIME
	Post-build time	X	VARIANT-POST-BUILD
Scope / Dependency	scope: local		

SWS Item	ECUC_J1939Rm_00025 :		
Name	J1939RmUserId		
Description	Identifier used by a module using J1939Rm. This parameter is only required when the module uses transmission of requests.		
Multiplicity	0..1		
Type	EcucIntegerParamDef (Symbolic Name generated for this parameter)		
Range	0 .. 65535		
Default value	--		
Post-Build Variant Multiplicity	false		
Post-Build Variant Value	false		
Multiplicity Configuration Class	Pre-compile time	X	All Variants
	Link time	--	
	Post-build time	--	
Value Configuration Class	Pre-compile time	X	All Variants
	Link time	--	
	Post-build time	--	
Scope / Dependency	scope: ECU		

SWS Item	ECUC_J1939Rm_00026 :		
Name	J1939RmUserPGN		
Description	<p>PGN supported to be requested from this module. The PGNs supported by different modules should usually be disjunctive.</p> <p>This parameter is predefined to AC (0x0EE00) for J1939RmUserType J1939RM_USER_J1939NM and is derived from the J1939Dcm PDUs in the system description for J1939RmUserType J1939RM_USER_J1939DCM. It shall not be set for J1939RmUserType J1939RM_USER_COM.</p>		
Multiplicity	0..*		
Type	EcucIntegerParamDef		
Range	0 .. 262143		
Default value	--		
Post-Build Variant Multiplicity	true		
Post-Build Variant Value	true		
Multiplicity Configuration Class	Pre-compile time	X	VARIANT-PRE-COMPILE
	Link time	X	VARIANT-LINK-TIME
	Post-build time	X	VARIANT-POST-BUILD
Value Configuration Class	Pre-compile time	X	VARIANT-PRE-COMPILE
	Link time	X	VARIANT-LINK-TIME
	Post-build time	X	VARIANT-POST-BUILD
Scope / Dependency	scope: local		

SWS Item	ECUC_J1939Rm_00027 :		
Name	J1939RmUserRequestIndication		
Description	<p>Enable RequestIndication for this module. In case of J1939Nm or J1939Dcm, the name is fixed. In case of CDD, the name is <apiServicePrefix>_RequestIndication. In case of RTE, J1939Rm will call the operation RequestIndication of the required port J1939Rm_RequestIndication_{user}.</p> <p>This parameter shall not be set for J1939RmUserType J1939RM_USER_COM.</p>		
Multiplicity	1		
Type	EcucBooleanParamDef		
Default value	--		
Post-Build Variant Value	false		
Value Configuration Class	Pre-compile time	X	All Variants
	Link time	--	
	Post-build time	--	
Scope / Dependency	scope: local		

SWS Item	ECUC_J1939Rm_00030 :		
Name	J1939RmUserSendAck		
Description	<p>Enable the SendAck API for this module. In case of RTE, the operation SendAck of the provided port J1939Rm_SendAck_{user} is called.</p> <p>This parameter shall not be set for J1939RmUserType J1939RM_USER_J1939NM or J1939RM_USER_COM.</p>		
Multiplicity	1		
Type	EcucBooleanParamDef		
Default value	--		
Post-Build Variant Value	false		
Value Configuration Class	Pre-compile time	X	All Variants
	Link time	--	
	Post-build time	--	
Scope / Dependency	scope: local		

SWS Item	ECUC_J1939Rm_00029 :		
Name	J1939RmUserSendRequest		
Description	<p>Enable the SendRequest API for this module. In case of RTE, the operation SendRequest of the provided port J1939Rm_SendRequest_{user} is called.</p> <p>This parameter shall not be set for J1939RmUserType J1939RM_USER_J1939NM, J1939RM_USER_J1939DCM, or J1939RM_USER_COM.</p>		
Multiplicity	1		
Type	EcucBooleanParamDef		
Default value	--		
Post-Build Variant Value	false		
Value Configuration Class	Pre-compile time	X	All Variants
	Link time	--	
	Post-build time	--	
Scope / Dependency	scope: local		

SWS Item	ECUC_J1939Rm_00031 :		
Name	J1939RmUserTimeoutSupervision		
Description	<p>Enable RequestTimeoutIndication and CancelRequestTimeout for this module.</p> <p>RequestTimeoutIndication: In case of CDD, the name is <apiServicePrefix>_RequestTimeoutIndication. In case of RTE, the operation RequestTimeoutIndication of the required port J1939Rm_RequestTimeoutIndication_{user} is called.</p> <p>CancelRequestTimeout: In case of RTE, the operation CancelRequestTimeout of the provided port J1939Rm_CancelRequestTimeout_{user} is called.</p> <p>This parameter shall not be set for J1939RmUserType J1939RM_USER_J1939NM, J1939RM_USER_J1939DCM, or J1939RM_USER_COM.</p>		
Multiplicity	1		
Type	EcucBooleanParamDef		
Default value	--		
Post-Build Variant Value	false		
Value Configuration Class	Pre-compile time	X	All Variants
	Link time	--	
	Post-build time	--	
Scope / Dependency	scope: local		

SWS Item	ECUC_J1939Rm_00024 :		
Name	J1939RmUserType		
Description	Type of module using J1939Rm.		
Multiplicity	1		
Type	EcucEnumerationParamDef		
Range	J1939RM_USER_CDD	CDDs may use all APIs provided by J1939Rm.	
	J1939RM_USER_COM	J1939Rm only supports requests for COM I-PDUs	
	J1939RM_USER_J1939DCM	J1939Dcm uses only request indication and transmission of acknowledgement.	
	J1939RM_USER_J1939NM	J1939Nm uses only request indication.	
	J1939RM_USER_RTE	Application SW-Cs may use all APIs provided by J1939Rm.	

Post-Build Variant Value	false		
Value Configuration Class	Pre-compile time	X	All Variants
	Link time	--	
	Post-build time	--	
Scope / Dependency	scope: local		

SWS Item	ECUC_J1939Rm_00042 :		
Name	J1939RmUserCddRef		
Description	Reference to the CDD module description. This parameter is only required for J1939RmUserType J1939RM_USER_CDD.		
Multiplicity	0..1		
Type	Foreign reference to [ECUC-MODULE-CONFIGURATION-VALUES]		
Post-Build Variant Multiplicity	false		
Post-Build Variant Value	false		
Multiplicity Configuration Class	Pre-compile time	X	All Variants
	Link time	--	
	Post-build time	--	
Value Configuration Class	Pre-compile time	X	All Variants
	Link time	--	
	Post-build time	--	
Scope / Dependency	scope: local		

Included Containers		
Container Name	Multiplicity	Scope / Dependency
J1939RmComIPdu	0..*	Contains the configuration of an I-PDU that is to be transmitted on request by COM. This configuration container is only relevant for J1939RmUserType J1939RM_USER_COM.

10.2.12 J1939RmComIPdu

SWS Item	ECUC_J1939Rm_00032 :		
Container Name	J1939RmComIPdu		
Description	Contains the configuration of an I-PDU that is to be transmitted on request by COM. This configuration container is only relevant for J1939RmUserType J1939RM_USER_COM.		
Post-Build Variant Multiplicity	true		
Multiplicity Configuration Class	Pre-compile time	X	VARIANT-PRE-COMPILE
	Link time	X	VARIANT-LINK-TIME
	Post-build time	X	VARIANT-POST-BUILD
Configuration Parameters			

SWS Item	ECUC_J1939Rm_00033 :		
Name	J1939RmComIPduPGN		
Description	PGN of the COM I-PDU.		
Multiplicity	1		
Type	EcucIntegerParamDef		
Range	0 .. 262143		
Default value	--		

Post-Build Variant Value	true		
Value Configuration Class	Pre-compile time	X	VARIANT-PRE-COMPILE
	Link time	X	VARIANT-LINK-TIME
	Post-build time	X	VARIANT-POST-BUILD
Scope / Dependency	scope: local		

SWS Item	ECUC_J1939Rm_00065 :		
Name	J1939RmComIPduRef		
Description	Reference to the Pdu object representing the I-PDU.		
Multiplicity	1		
Type	Reference to [Pdu]		
Post-Build Variant Value	false		
Value Configuration Class	Pre-compile time	X	VARIANT-PRE-COMPILE
	Link time	X	VARIANT-LINK-TIME, VARIANT-POST-BUILD
	Post-build time	--	
Scope / Dependency	scope: local		

No Included Containers

10.3 Published Information

For details, refer to the chapter 10.3 “Published Information” in the SWS BSW General [4].