

Document Title	Specification of Flash Driver
Document Owner	AUTOSAR
Document Responsibility	AUTOSAR
Document Identification No	025
Document Classification	Standard
Document Status	Final
Part of Release	4.2.2

Document Change History		
Release	Changed by	Change Description
4.2.2	AUTOSAR Release Management	<ul style="list-style-type: none"> • Debugging support marked as obsolete • Error classification reworked • Reference to DEM removed • Description for configuration parameter FlsUseInterrupts clarified
4.2.1	AUTOSAR Release Management	<ul style="list-style-type: none"> • Requirements linked to features and BSW requirements.
4.1.3	AUTOSAR Release Management	<ul style="list-style-type: none"> • Requirements for NULL pointer check during Fls_Init removed • Minor formatting changes
4.1.2	AUTOSAR Release Management	<ul style="list-style-type: none"> • Timing requirement removed from module's main function • Fls_GetStatus returns MEMIF_UNINIT if module is not initialized • Editorial changes • Removed chapter(s) on change documentation
4.1.1	AUTOSAR Administration	<ul style="list-style-type: none"> • Reworked according to the new SWS_BSWGeneral • Scope attribute in tables in chapter 10 added • Production errors changed to extended production errors • Requirement IDs for type definitions added
4.0.3	AUTOSAR Administration	<ul style="list-style-type: none"> • References to HW specific errors corrected • Range of configuration parameters adapted • Consistency checking reformulated • Module short name changed
3.1.5	AUTOSAR Administration	<ul style="list-style-type: none"> • Configuration parameter FlsDefaultMode added • Container with SPI reference added • Check for NULL pointer added

Document Change History		
Release	Changed by	Change Description
3.1.4	AUTOSAR Administration	<ul style="list-style-type: none"> References to AUTOSAR Standard Errors added Range of configuration parameters restricted Multiplicity of notification routines corrected Several typing and formatting errors corrected Legal disclaimer revised
3.1.1	AUTOSAR Administration	<ul style="list-style-type: none"> Legal disclaimer revised
3.0.2	AUTOSAR Administration	<ul style="list-style-type: none"> Table formatting corrected
3.0.1	AUTOSAR Administration	<ul style="list-style-type: none"> NULL pointer check added to Fls_Compare NULL pointer check detailed (in general) Restriction removed to allow re-initialization of module Tables in chapters 8 and 10 generated from UML model Document meta information extended Small layout adaptations made
2.1.15	AUTOSAR Administration	<ul style="list-style-type: none"> File include structure updated Type usage corrected Compare Job results adapted API towards DEM corrected Legal disclaimer revised Release Notes added “Advice for users” revised “Revision Information” added
2.0	AUTOSAR Administration	<ul style="list-style-type: none"> Document structure adapted to common Release 2.0 SWS Template new functionality: Read, Compare and SetMode functions scalability: functionality can be configured (on/off) adapted to new MemHwA architecture
1.0	AUTOSAR Administration	<ul style="list-style-type: none"> Initial release

Disclaimer

This specification and the material contained in it, as released by AUTOSAR, is for the purpose of information only. AUTOSAR and the companies that have contributed to it shall not be liable for any use of the specification.

The material contained in this specification is protected by copyright and other types of Intellectual Property Rights. The commercial exploitation of the material contained in this specification requires a license to such Intellectual Property Rights.

This specification may be utilized or reproduced without any modification, in any form or by any means, for informational purposes only. For any other purpose, no part of the specification may be utilized or reproduced, in any form or by any means, without permission in writing from the publisher.

The AUTOSAR specifications have been developed for automotive applications only. They have neither been developed, nor tested for non-automotive applications.

The word AUTOSAR and the AUTOSAR logo are registered trademarks.

Advice for users

AUTOSAR specifications may contain exemplary items (exemplary reference models, "use cases", and/or references to exemplary technical solutions, devices, processes or software).

Any such exemplary items are contained in the specifications for illustration purposes only, and they themselves are not part of the AUTOSAR Standard. Neither their presence in such specifications, nor any later documentation of AUTOSAR conformance of products actually implementing such exemplary items, imply that intellectual property rights covering such exemplary items are licensed under the same rules as applicable to the AUTOSAR Standard.

Table of Contents

1	Introduction and functional overview	6
2	Acronyms and abbreviations	7
3	Related documentation.....	8
3.1	AUTOSAR deliverables	8
3.2	Related standards and norms	8
3.3	Related specification	8
4	Constraints and assumptions	10
4.1	Limitations	10
4.2	Applicability to car domains	10
5	Dependencies to other modules.....	11
5.1	Header File Structure	11
5.2	System clock	12
5.3	Communication or I/O drivers.....	12
6	Requirements traceability	13
7	Functional specification	24
7.1	General design rules	24
7.2	Error classification	25
7.3	Production Errors.....	26
7.4	Runtime Errors	26
7.5	External flash driver.....	27
7.6	Loading, executing and removing the flash access code	27
7.7	Support for Debugging	28
8	API specification.....	29
8.1	Imported types.....	29
8.2	Type definitions	29
8.2.1	Fls_ConfigType.....	29
8.2.2	Fls_AddressType	29
8.2.3	Fls_LengthType	30
8.3	Function definitions.....	30
8.3.1	Fls_Init	30
8.3.2	Fls_Erase.....	31
8.3.3	Fls_Write.....	33
8.3.4	Fls_Cancel.....	35
8.3.5	Fls_GetStatus	36
8.3.6	Fls_GetJobResult	37
8.3.7	Fls_Read	38
8.3.8	Fls_Compare	39
8.3.9	Fls_SetMode.....	41
8.3.10	Fls_GetVersionInfo.....	42
8.3.11	Fls_BlankCheck.....	43
8.4	Call-back notifications.....	44

8.5	Scheduled functions	45
8.5.1	Fls_MainFunction.....	45
8.6	Expected Interfaces.....	48
8.6.1	Mandatory Interfaces	48
8.6.2	Optional Interfaces.....	49
8.6.3	Configurable interfaces	49
9	Sequence diagrams	51
9.1	Initialization.....	51
9.2	Synchronous functions	51
9.3	Asynchronous functions	52
9.4	Canceling a running job.....	53
10	Configuration specification.....	54
10.1	Containers and configuration parameters	54
10.1.1	Variants	54
10.1.2	Fls.....	55
10.1.3	FlsGeneral	55
10.1.4	FlsConfigSet.....	59
10.1.5	FlsDemEventParameterRefs	63
10.1.6	FlsExternalDriver	65
10.1.7	FlsSectorList.....	66
10.1.8	FlsSector	66
10.2	Published Information.....	67
10.2.1	FlsPublishedInformation	67
11	Not applicable requirements	71

1 Introduction and functional overview

This document specifies the functionality, API and the configuration of the AUTOSAR Basic Software module Flash Driver.

This specification is applicable to drivers for both internal and external flash memory.

The flash driver provides services for reading, writing and erasing flash memory and a configuration interface for setting / resetting the write / erase protection if supported by the underlying hardware.

In application mode of the ECU, the flash driver is only to be used by the Flash EEPROM emulation module for writing data. It is not intended to write program code to flash memory in application mode. This shall be done in boot mode which is out of scope of AUTOSAR.

A driver for an internal flash memory accesses the microcontroller hardware directly and is located in the Microcontroller Abstraction Layer. An external flash memory is usually connected via the microcontroller's data / address busses (memory mapped access), the flash driver then uses the handlers / drivers for those busses to access the external flash memory device. The driver for an external flash memory device is located in the ECU Abstraction Layer.

[SWS_FIs_00088] [The functional requirements and the functional scope are the same for both internal and external drivers. Hence the API is semantically identical.]
(SRS_FIs_12147, SRS_FIs_12148)

2 Acronyms and abbreviations

Abbreviation / Acronym:	Description:
DET	Default Error Tracer – module to which development errors are reported.
DEM	Diagnostic Event Manager – module to which production relevant errors are reported.
Fls, FLS	Official AUTOSAR abbreviation for the module flash driver (different writing depending on the context, same meaning).
AC	(Flash) access code – abbreviation introduced to keep the names of the configuration parameters reasonably short.

Further definitions of terms used throughout this document

Term:	Definition
Flash sector	A flash sector is the smallest amount of flash memory that can be erased in one pass. The size of the flash sector depends upon the flash technology and is therefore hardware dependent.
Flash page	A flash page is the smallest amount of flash memory that can be programmed in one pass. The size of the flash page depends upon the flash technology and is therefore hardware dependent.
Flash access code	Internal flash driver routines called by the main function (job processing function) to erase or write the flash hardware.

3 Related documentation

3.1 AUTOSAR deliverables

- [1] List of Basic Software Modules
AUTOSAR_TR_BSWModuleList.pdf
- [2] Layered Software Architecture,
AUTOSAR_EXP_LayeredSoftwareArchitecture.pdf
- [3] General Requirements on Basic Software Modules,
AUTOSAR_SRS_BSWGeneral.pdf
- [4] General Requirements on SPAL,
AUTOSAR_SRS_SPALGeneral.pdf
- [5] Requirements on Flash Driver
AUTOSAR_SRS_FlashDriver.pdf
- [6] Requirements on Memory Hardware Abstraction Layer
AUTOSAR_SRS_MemoryHWAbstractionLayer.pdf
- [7] Specification of ECU Configuration
AUTOSAR_TPS_ECUConfiguration.pdf
- [8] Basic Software Module Description Template
AUTOSAR_TPS_BSWModuleDescriptionTemplate.pdf
- [9] General Specification of Basic Software Modules
AUTOSAR_SWS_BSWGeneral.pdf

3.2 Related standards and norms

- [10] HIS Flash Driver Specification
HIS flash driver v130.pdf on
<http://www.automotive-his.de/download/>

3.3 Related specification

AUTOSAR provides a General Specification on Basic Software modules [9] (SWS BSW General), which is also valid for Flash Driver.

Thus, the specification SWS BSW General shall be considered as additional and required specification for Flash Driver.

4 Constraints and assumptions

4.1 Limitations

- The flash driver only erases or programs complete flash sectors respectively flash pages, i.e. it does not offer any kind of re-write strategy since it does not use any internal buffers.
- The flash driver does not provide mechanisms for providing data integrity (e.g. checksums, redundant storage, etc.).

4.2 Applicability to car domains

No restrictions.

5 Dependencies to other modules

5.1 Header File Structure

[SWS_Fls_00107] [The Fls module shall comply with the following file structure:

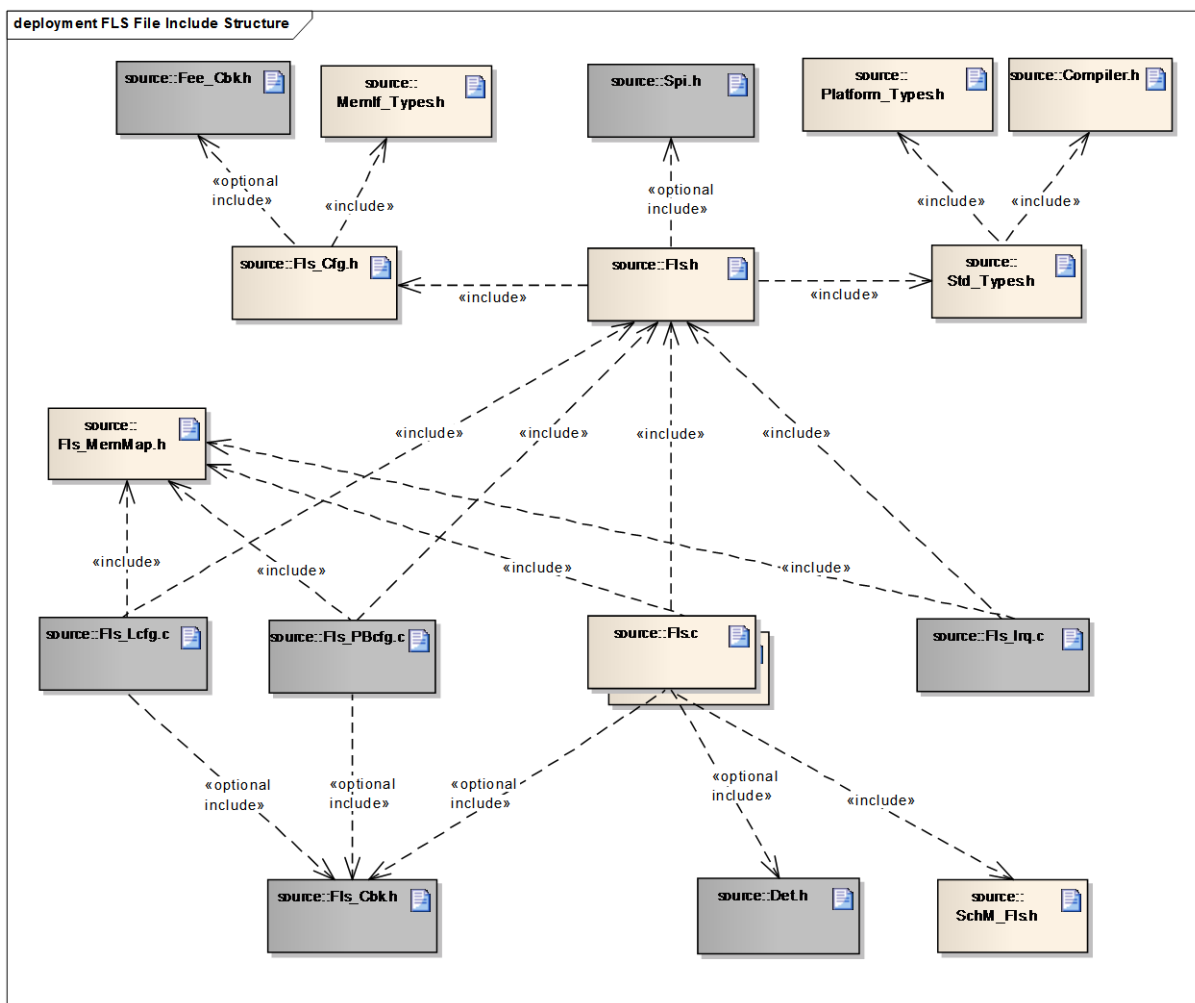

Figure 1: File include structure

Note: The files shown in grey are optional and might not be present for all implementations and/or configurations of a specific implementation of the FLS module.

] (SRS_BSW_00381, SRS_BSW_00412, SRS_BSW_00409, SRS_BSW_00346, SRS_BSW_00158, SRS_BSW_00301)

[SWS_Fls_00308] [Types and definitions common to several flash driver instances shall be given in the header file MemIf_Types.h.] (SRS_BSW_00392, SRS_BSW_00456)

[SWS_Fls_00309] [Types and definitions specific for one flash driver shall be given in the header file `Fls.h`.] (SRS_BSW_00392, SRS_BSW_00415)

5.2 System clock

If the hardware of the internal flash memory depends on the system clock, changes to the system clock (e.g. PLL on → PLL off) may also affect the clock settings of the flash memory hardware.

5.3 Communication or I/O drivers

If the flash memory is located in an external device, the access to this device shall be enacted via the corresponding communication respectively I/O driver.

6 Requirements traceability

Requirement	Description	Satisfied by
-	-	SWS_Fls_00371
RS_BRF_01064	AUTOSAR BSW shall provide callback functions in order to access upper layer modules	SWS_Fls_00147, SWS_Fls_00262, SWS_Fls_00273 SWS_Fls_00167, SWS_Fls_00263,
RS_BRF_01076	AUTOSAR basic software shall perform module local error recovery to the extent possible	SWS_Fls_00272, SWS_Fls_00360, SWS_Fls_00362, SWS_Fls_00373 SWS_Fls_00359, SWS_Fls_00361,
RS_BRF_01144	AUTOSAR shall support configuration parameters which allow to trade interrupt response time against runtime	SWS_Fls_00233, SWS_Fls_00234
RS_BRF_02240	AUTOSAR debugging shall provide relevant internal data of Basic Software to the developer	SWS_Fls_00302
SRS_BSW_00004	All Basic SW Modules shall perform a pre-processor check of the versions of all imported include files	SWS_Fls_00205, SWS_Fls_00206
SRS_BSW_00005	Modules of the $\hat{\mu}$ C Abstraction Layer (MCAL) may not have hard coded horizontal interfaces	SWS_Fls_00366
SRS_BSW_00006	The source code of software modules above the $\hat{\mu}$ C Abstraction Layer (MCAL) shall not be processor and compiler dependent.	SWS_Fls_00366
SRS_BSW_00007	All Basic SW Modules written in C language shall conform to the MISRA C 2004 Standard.	SWS_Fls_00366
SRS_BSW_00009	All Basic SW Modules shall be documented according to a common standard.	SWS_Fls_00366
SRS_BSW_00010	The memory consumption of all Basic SW Modules shall be documented for a defined configuration for all supported platforms.	SWS_Fls_00366
SRS_BSW_00101	The Basic Software Module shall be able to initialize variables and hardware in a separate initialization function	SWS_Fls_00014, SWS_Fls_00191, SWS_Fls_00351 SWS_Fls_00086, SWS_Fls_00249,

SRS_BSW_00158	All modules of the AUTOSAR Basic Software shall strictly separate configuration from implementation	SWS_Fls_00107
SRS_BSW_00160	Configuration files of AUTOSAR Basic SW module shall be readable for human beings	SWS_Fls_00366
SRS_BSW_00161	The AUTOSAR Basic Software shall provide a microcontroller abstraction layer which provides a standardized interface to higher software layers	SWS_Fls_00366
SRS_BSW_00162	The AUTOSAR Basic Software shall provide a hardware abstraction layer	SWS_Fls_00366
SRS_BSW_00164	The Implementation of interrupt service routines shall be done by the Operating System, complex drivers or modules	SWS_Fls_00193, SWS_Fls_00232
SRS_BSW_00167	All AUTOSAR Basic Software Modules shall provide configuration rules and constraints to enable plausibility checks	SWS_Fls_00205, SWS_Fls_00206
SRS_BSW_00168	SW components shall be tested by a function defined in a common API in the Basis-SW	SWS_Fls_00366
SRS_BSW_00170	The AUTOSAR SW Components shall provide information about their dependency from faults, signal qualities, driver demands	SWS_Fls_00366
SRS_BSW_00171	Optional functionality of a Basic-SW component that is not required in the ECU shall be configurable at pre-compile-time	SWS_Fls_00183, SWS_Fls_00184, SWS_Fls_00185, SWS_Fls_00186, SWS_Fls_00187
SRS_BSW_00172	The scheduling strategy that is built inside the Basic Software Modules shall be compatible with the strategy used in the system	SWS_Fls_00366
SRS_BSW_00300	All AUTOSAR Basic Software Modules shall be identified by an unambiguous name	SWS_Fls_00366
SRS_BSW_00301	All AUTOSAR Basic	SWS_Fls_00107

	Software Modules shall only import the necessary information		
SRS_BSW_00302	All AUTOSAR Basic Software Modules shall only export information needed by other modules	SWS_Fls_00366	
SRS_BSW_00304	All AUTOSAR Basic Software Modules shall use the following data types instead of native C data types	SWS_Fls_00366	
SRS_BSW_00306	AUTOSAR Basic Software Modules shall be compiler and platform independent	SWS_Fls_00366	
SRS_BSW_00307	Global variables naming convention	SWS_Fls_00366	
SRS_BSW_00308	AUTOSAR Basic Software Modules shall not define global data in their header files, but in the C file	SWS_Fls_00366	
SRS_BSW_00309	All AUTOSAR Basic Software Modules shall indicate all global data with read-only purposes by explicitly assigning the const keyword	SWS_Fls_00366	
SRS_BSW_00312	Shared code shall be reentrant	SWS_Fls_00366	
SRS_BSW_00314	All internal driver modules shall separate the interrupt frame definition from the service routine	SWS_Fls_00366	
SRS_BSW_00321	The version numbers of AUTOSAR Basic Software Modules shall be enumerated according specific rules	SWS_Fls_00366	
SRS_BSW_00323	All AUTOSAR Basic Software Modules shall check passed API parameters for validity	SWS_Fls_00015, SWS_Fls_00021, SWS_Fls_00027, SWS_Fls_00098, SWS_Fls_00205, SWS_Fls_00363	SWS_Fls_00020, SWS_Fls_00026, SWS_Fls_00097, SWS_Fls_00157, SWS_Fls_00206,
SRS_BSW_00325	The runtime of interrupt service routines and functions that are running in interrupt context shall be kept short	SWS_Fls_00193	
SRS_BSW_00326	-	SWS_Fls_00366	
SRS_BSW_00327	Error values naming convention	SWS_Fls_00310, SWS_Fls_00312, SWS_Fls_00314,	SWS_Fls_00311, SWS_Fls_00313, SWS_Fls_00315,

		SWS_Fls_00316, SWS_Fls_00317, SWS_Fls_00318, SWS_Fls_00319
SRS_BSW_00328	All AUTOSAR Basic Software Modules shall avoid the duplication of code	SWS_Fls_00366
SRS_BSW_00330	It shall be allowed to use macros instead of functions where source code is used and runtime is critical	SWS_Fls_00366
SRS_BSW_00331	All Basic Software Modules shall strictly separate error and status information	SWS_Fls_00310, SWS_Fls_00311, SWS_Fls_00312, SWS_Fls_00313, SWS_Fls_00314, SWS_Fls_00315, SWS_Fls_00316, SWS_Fls_00317, SWS_Fls_00318, SWS_Fls_00319
SRS_BSW_00333	For each callback function it shall be specified if it is called from interrupt context or not	SWS_Fls_00366
SRS_BSW_00334	All Basic Software Modules shall provide an XML file that contains the meta data	SWS_Fls_00366
SRS_BSW_00336	Basic SW module shall be able to shutdown	SWS_Fls_00366
SRS_BSW_00337	Classification of development errors	SWS_Fls_00310, SWS_Fls_00311, SWS_Fls_00312, SWS_Fls_00313, SWS_Fls_00314, SWS_Fls_00315, SWS_Fls_00316, SWS_Fls_00317, SWS_Fls_00318, SWS_Fls_00319
SRS_BSW_00339	Reporting of production relevant error status	SWS_Fls_00104, SWS_Fls_00105, SWS_Fls_00106, SWS_Fls_00154, SWS_Fls_00260, SWS_Fls_00366
SRS_BSW_00341	Module documentation shall contains all needed informations	SWS_Fls_00366
SRS_BSW_00342	It shall be possible to create an AUTOSAR ECU out of modules provided as source code and modules provided as object code, even mixed	SWS_Fls_00366
SRS_BSW_00344	BSW Modules shall support link-time configuration	SWS_Fls_00366
SRS_BSW_00345	BSW Modules shall support pre-compile configuration	SWS_Fls_00171
SRS_BSW_00346	All AUTOSAR Basic Software Modules shall provide at least a basic set of module files	SWS_Fls_00107
SRS_BSW_00347	A Naming separation of	SWS_Fls_00366

	different instances of BSW drivers shall be in place		
SRS_BSW_00348	All AUTOSAR standard types and constants shall be placed and organized in a standard type header file	SWS_Fls_00366	
SRS_BSW_00353	All integer type definitions of target and compiler specific scope shall be placed and organized in a single type header	SWS_Fls_00366	
SRS_BSW_00355	-	SWS_Fls_00366	
SRS_BSW_00359	All AUTOSAR Basic Software Modules callback functions shall avoid return types other than void if possible	SWS_Fls_00366	
SRS_BSW_00360	AUTOSAR Basic Software Modules callback functions are allowed to have parameters	SWS_Fls_00366	
SRS_BSW_00361	All mappings of not standardized keywords of compiler specific scope shall be placed and organized in a compiler specific type and keyword header	SWS_Fls_00366	
SRS_BSW_00370	-	SWS_Fls_00366	
SRS_BSW_00371	The passing of function pointers as API parameter is forbidden for all AUTOSAR Basic Software Modules	SWS_Fls_00366	
SRS_BSW_00375	Basic Software Modules shall report wake-up reasons	SWS_Fls_00366	
SRS_BSW_00378	AUTOSAR shall provide a boolean type	SWS_Fls_00366	
SRS_BSW_00381	The pre-compile time parameters shall be placed into a separate configuration header file	SWS_Fls_00107	
SRS_BSW_00385	List possible error notifications	SWS_Fls_00004, SWS_Fls_00105, SWS_Fls_00154, SWS_Fls_00311, SWS_Fls_00313, SWS_Fls_00315, SWS_Fls_00317, SWS_Fls_00319	SWS_Fls_00104, SWS_Fls_00106, SWS_Fls_00310, SWS_Fls_00312, SWS_Fls_00314, SWS_Fls_00316, SWS_Fls_00318,
SRS_BSW_00387	-	SWS_Fls_00109, SWS_Fls_00167,	SWS_Fls_00110, SWS_Fls_00262,

		SWS_Fls_00263, SWS_Fls_00348, SWS_Fls_00366	SWS_Fls_00347, SWS_Fls_00349,
SRS_BSW_00388	Containers shall be used to group configuration parameters that are defined for the same object	SWS_Fls_00352	
SRS_BSW_00392	Parameters shall have a type	SWS_Fls_00248, SWS_Fls_00309, SWS_Fls_00369,	SWS_Fls_00308, SWS_Fls_00368, SWS_Fls_00370
SRS_BSW_00398	The link-time configuration is achieved on object code basis in the stage after compiling and before linking	SWS_Fls_00366	
SRS_BSW_00401	Documentation of multiple instances of configuration parameters shall be available	SWS_Fls_00366	
SRS_BSW_00404	BSW Modules shall support post-build configuration	SWS_Fls_00014	
SRS_BSW_00405	BSW Modules shall support multiple configuration sets	SWS_Fls_00014	
SRS_BSW_00406	A static status variable denoting if a BSW module is initialized shall be initialized with value 0 before any APIs of the BSW module is called	SWS_Fls_00065, SWS_Fls_00099, SWS_Fls_00240, SWS_Fls_00358, SWS_Fls_00383	SWS_Fls_00066, SWS_Fls_00117, SWS_Fls_00268, SWS_Fls_00382,
SRS_BSW_00407	Each BSW module shall provide a function to read out the version information of a dedicated module implementation	SWS_Fls_00259	
SRS_BSW_00409	All production code error ID symbols are defined by the Dem module and shall be retrieved by the other BSW modules from Dem configuration	SWS_Fls_00107	
SRS_BSW_00412	References to c-configuration parameters shall be placed into a separate h-file	SWS_Fls_00107	
SRS_BSW_00415	Interfaces which are provided exclusively for one module shall be separated into a dedicated header file	SWS_Fls_00309, SWS_Fls_00366	
SRS_BSW_00416	The sequence of modules to be initialized shall be	SWS_Fls_00366	

	configurable	
SRS_BSW_00417	Software which is not part of the SW-C shall report error events only after the DEM is fully operational.	SWS_Fls_00366
SRS_BSW_00422	Pre-de-bouncing of error status information is done within the DEM	SWS_Fls_00366
SRS_BSW_00423	BSW modules with AUTOSAR interfaces shall be describable with the means of the SW-C Template	SWS_Fls_00366
SRS_BSW_00424	BSW module main processing functions shall not be allowed to enter a wait state	SWS_Fls_00366
SRS_BSW_00426	BSW Modules shall ensure data consistency of data which is shared between BSW modules	SWS_Fls_00366
SRS_BSW_00427	ISR functions shall be defined and documented in the BSW module description template	SWS_Fls_00366
SRS_BSW_00428	A BSW module shall state if its main processing function(s) has to be executed in a specific order or sequence	SWS_Fls_00366
SRS_BSW_00429	BSW modules shall be only allowed to use OS objects and/or related OS services	SWS_Fls_00366
SRS_BSW_00432	Modules should have separate main processing functions for read/receive and write/transmit data path	SWS_Fls_00269
SRS_BSW_00433	Main processing functions are only allowed to be called from task bodies provided by the BSW Scheduler	SWS_Fls_00366
SRS_BSW_00438	Configuration data shall be defined in a structure	SWS_Fls_00352, SWS_Fls_00353, SWS_Fls_00354, SWS_Fls_00355
SRS_BSW_00442	{OBSOLETE} The AUTOSAR architecture shall support standardized debugging and tracing features	SWS_Fls_00261
SRS_BSW_00456	- A Header file shall be defined in order to harmonize BSW Modules	SWS_Fls_00308

SRS_BSW_00466	Classification of extended production errors	SWS_Fls_00104, SWS_Fls_00105, SWS_Fls_00106, SWS_Fls_00154
SRS_BSW_00469	Fault detection and healing of production errors and extended production errors	SWS_Fls_00260
SRS_Fls_00134	-	SWS_Fls_00001
SRS_Fls_00135	-	SWS_Fls_00001
SRS_Fls_00136	-	SWS_Fls_00001
SRS_Fls_00323	-	SWS_Fls_00158
SRS_Fls_12083	HIS specification shall be used as basis for specifying the Flash driver	SWS_Fls_00366
SRS_Fls_12107	The external flash driver shall check if the configured flash type matches with the hardware flash ID	SWS_Fls_00144
SRS_Fls_12132	Flash driver shall be statically configurable	SWS_Fls_00048, SWS_Fls_00171, SWS_Fls_00208, SWS_Fls_00209, SWS_Fls_00216, SWS_Fls_00217
SRS_Fls_12134	The flash driver shall provide an asynchronous read function	SWS_Fls_00035, SWS_Fls_00097, SWS_Fls_00098, SWS_Fls_00236, SWS_Fls_00238, SWS_Fls_00239, SWS_Fls_00254, SWS_Fls_00256, SWS_Fls_00337, SWS_Fls_00338, SWS_Fls_00339, SWS_Fls_00340
SRS_Fls_12135	The flash driver shall provide an asynchronous write function	SWS_Fls_00026, SWS_Fls_00027, SWS_Fls_00035, SWS_Fls_00146, SWS_Fls_00223, SWS_Fls_00225, SWS_Fls_00226, SWS_Fls_00251, SWS_Fls_00254, SWS_Fls_00331, SWS_Fls_00332, SWS_Fls_00333, SWS_Fls_00334
SRS_Fls_12136	The flash driver shall provide an asynchronous erase function	SWS_Fls_00020, SWS_Fls_00021, SWS_Fls_00035, SWS_Fls_00145, SWS_Fls_00218, SWS_Fls_00220, SWS_Fls_00221, SWS_Fls_00250, SWS_Fls_00254, SWS_Fls_00327, SWS_Fls_00328, SWS_Fls_00329, SWS_Fls_00330
SRS_Fls_12137	The flash driver shall provide a synchronous cancel function	SWS_Fls_00033, SWS_Fls_00183, SWS_Fls_00229, SWS_Fls_00230, SWS_Fls_00252, SWS_Fls_00335, SWS_Fls_00336
SRS_Fls_12138	The flash driver shall provide a synchronous status function	SWS_Fls_00034, SWS_Fls_00184, SWS_Fls_00253
SRS_Fls_12141	The flash driver shall verify written data	SWS_Fls_00056, SWS_Fls_00200
SRS_Fls_12143	The flash driver shall handle only one job at one time	SWS_Fls_00002, SWS_Fls_00003, SWS_Fls_00023, SWS_Fls_00030, SWS_Fls_00033, SWS_Fls_00036,

		SWS_Fls_00100, SWS_Fls_00323, SWS_Fls_00324	SWS_Fls_00268, SWS_Fls_00324
SRS_Fls_12144	The flash driver shall provide a function that has to be called for job processing	SWS_Fls_00037, SWS_Fls_00039, SWS_Fls_00220, SWS_Fls_00235, SWS_Fls_00243, SWS_Fls_00272, SWS_Fls_00346, SWS_Fls_00375, SWS_Fls_00377, SWS_Fls_00379	SWS_Fls_00038, SWS_Fls_00196, SWS_Fls_00225, SWS_Fls_00238, SWS_Fls_00255, SWS_Fls_00345, SWS_Fls_00374, SWS_Fls_00376, SWS_Fls_00378,
SRS_Fls_12145	The job processing function of the flash driver shall process only as much data as the flash hardware can handle	SWS_Fls_00040	
SRS_Fls_12147	The same requirements shall apply for an external and internal flash driver	SWS_Fls_00088	
SRS_Fls_12148	The external flash driver shall have a semantically identical API as an internal flash driver	SWS_Fls_00088	
SRS_Fls_12149	The source code of the external flash driver shall be independent from the underlying microcontroller	SWS_Fls_00366	
SRS_Fls_12158	Before writing, the flash driver shall verify if the addressed memory area has been erased	SWS_Fls_00055	
SRS_Fls_12159	The write and erase functions of the Flash driver shall check the passed address parameters	SWS_Fls_00020, SWS_Fls_00026, SWS_Fls_00097, SWS_Fls_00380, SWS_Fls_00381	SWS_Fls_00021, SWS_Fls_00027, SWS_Fls_00098,
SRS_Fls_12160	After execution of an erase job, the flash driver shall verify that the addressed block has been erased completely	SWS_Fls_00022	
SRS_Fls_12184	The flash driver shall limit the read access blocking times to the configured time	SWS_Fls_00040	
SRS_Fls_12193	The flash driver shall load the code that accesses the flash hardware to RAM whenever an erase or write job is started	SWS_Fls_00137, SWS_Fls_00141, SWS_Fls_00214	SWS_Fls_00140,
SRS_Fls_12194	The flash driver shall execute the code that accesses the flash	SWS_Fls_00211, SWS_Fls_00213, SWS_Fls_00215	SWS_Fls_00212,

	hardware from RAM	
SRS_Fls_13300	The flash driver shall remove the code that accesses the flash hardware from RAM after the current job has been finished or canceled	SWS_Fls_00143
SRS_Fls_13301	The flash driver shall provide an asynchronous compare function	SWS_Fls_00001, SWS_Fls_00150, SWS_Fls_00151, SWS_Fls_00152, SWS_Fls_00153, SWS_Fls_00186, SWS_Fls_00241, SWS_Fls_00243, SWS_Fls_00244, SWS_Fls_00257, SWS_Fls_00341, SWS_Fls_00342, SWS_Fls_00343, SWS_Fls_00344
SRS_Fls_13302	The flash driver shall provide a synchronous selection function	SWS_Fls_00155, SWS_Fls_00156, SWS_Fls_00187, SWS_Fls_00258
SRS_Fls_13303	In normal mode, one cycle of the job processing function of the flash driver shall limit the block size to the default block size	SWS_Fls_00040
SRS_Fls_13304	In fast mode, one cycle of the job processing function of the flash driver shall limit the block size to the maximum block size	SWS_Fls_00040
SRS_MemHwAb_14005	The FEE and EA modules shall provide upper layers with a virtual 32bit address space	SWS_Fls_00209, SWS_Fls_00216, SWS_Fls_00217
SRS_SPAL_12057	All driver modules shall implement an interface for initialization	SWS_Fls_00014
SRS_SPAL_12063	All driver modules shall only support raw value mode	SWS_Fls_00366
SRS_SPAL_12064	All driver modules shall raise an error if the change of the operation mode leads to degradation of running operations	SWS_Fls_00366
SRS_SPAL_12067	All driver modules shall set their wake-up conditions depending on the selected operation mode	SWS_Fls_00366
SRS_SPAL_12069	All drivers of the SPAL that wake up from a wake-up interrupt shall report the wake-up reason	SWS_Fls_00366
SRS_SPAL_12078	The drivers shall be coded in a way that is most efficient in terms of	SWS_Fls_00366

	memory and runtime resources	
SRS_SPAL_12163	All driver modules shall implement an interface for de-initialization	SWS_Fls_00366
SRS_SPAL_12267	Wakeup sources shall be initialized by MCAL drivers and/or the MCU driver	SWS_Fls_00366
SRS_SPAL_12462	The register initialization settings shall be published	SWS_Fls_00366
SRS_SPAL_12463	The register initialization settings shall be combined and forwarded	SWS_Fls_00366
SRS_SWS_12137	-	SWS_Fls_00035, SWS_Fls_00254
SWS_BSW_00345	-	SWS_Fls_00203
SWS_BSW_00404	-	SWS_Fls_00204
SWS_BSW_00406	-	SWS_Fls_00356

7 Functional specification

7.1 General design rules

[SWS_Fls_00001] [The FLS module shall offer asynchronous services for operations on flash memory (read/erase/write).] (SRS_Fls_00134, SRS_Fls_00135, SRS_Fls_00136, SRS_Fls_13301)

[SWS_Fls_00002] [The FLS module shall not buffer data. The FLS module shall use application data buffers that are referenced by a pointer passed via the API.] (SRS_Fls_12143)

[SWS_Fls_00003] [The FLS module shall not ensure data consistency of the given application buffer.] (SRS_Fls_12143)

It is the responsibility of the FLS module's environment to ensure consistency of flash data during a flash read or write operation.

[SWS_Fls_00205] [The FLS module shall check static configuration parameters statically (at the latest during compile time) for correctness.] (SRS_BSW_00323, SRS_BSW_00167, SRS_BSW_00004)

[SWS_Fls_00206] [The FLS module shall validate the version information in the FLS module header and source files for consistency (e.g. by comparing the version information in the module header and source files with a pre-processor macro).] (SRS_BSW_00323, SRS_BSW_00167, SRS_BSW_00004)

[SWS_Fls_00208] [The FLS module shall combine all available flash memory areas into one linear address space (denoted by the parameters `FlsBaseAddress` and `FlsTotalSize`).] (SRS_Fls_12132)

[SWS_Fls_00209] [The FLS module shall map the address and length parameters for the read, write, erase and compare functions as "virtual" addresses to the physical addresses according to the physical structure of the flash memory areas.] (SRS_Fls_12132, SRS_MemHwAb_14005)

As long as the restrictions regarding the alignment of those addresses are met, it is allowed that a read, write or erase job crosses the boundaries of a physical flash memory area.

7.2 Error classification

The FLS module shall be able to detect the following errors and exceptions depending on its configuration (development/production):

[SWS_Fls_00004] [

Type or error	Relevance	Related error code	Value [hex]
API service called with wrong parameter	Development	FLS_E_PARAM_CONFIG FLS_E_PARAM_ADDRESS FLS_E_PARAM_LENGTH FLS_E_PARAM_DATA	0x01 0x02 0x03 0x04
API service called without module initialization	Development	FLS_E_UNINIT	0x05
API service called while driver still busy	Development	FLS_E_BUSY	0x06
Erase verification (blank check) failed	Development	FLS_E_VERIFY_ERASE_FAILED	0x07
Write verification (compare) failed	Development	FLS_E_VERIFY_WRITE_FAILED	0x08
Timeout exceeded	Development	FLS_E_TIMEOUT	0x09
API service called with NULL pointer	Development	FLS_E_PARAM_POINTER	0x0a

] (SRS_BSW_00385)

[SWS_Fls_00310] [The following development error codes shall be reported when an API service is called with a wrong parameter: FLS_E_PARAM_CONFIG, FLS_E_PARAM_ADDRESS, FLS_E_PARAM_LENGTH, FLS_E_PARAM_DATA.] (SRS_BSW_00337, SRS_BSW_00385, SRS_BSW_00327, SRS_BSW_00331)

[SWS_Fls_00311] [The development error code FLS_E_UNINIT shall be reported when an API service is called prior to module initialization. Exceptions are the functions Fls_Init and Fls_GetVersionInfo.] (SRS_BSW_00337, SRS_BSW_00385, SRS_BSW_00327, SRS_BSW_00331)

[SWS_Fls_00312] [The development error code FLS_E_BUSY shall be reported when an API service is called while the module is still busy.] (SRS_BSW_00337, SRS_BSW_00385, SRS_BSW_00327, SRS_BSW_00331)

[SWS_Fls_00313] [The development error code FLS_E_VERIFY_ERASE_FAILED shall be reported when the erase verification (blankcheck) failed.] (SRS_BSW_00337, SRS_BSW_00385, SRS_BSW_00327, SRS_BSW_00331)

[SWS_Fls_00314] [The development error code FLS_E_VERIFY_WRITE shall be reported when the write verification (compare) failed.] (SRS_BSW_00337, SRS_BSW_00385, SRS_BSW_00327, SRS_BSW_00331)

[SWS_Fls_00361] [The development error code `FLS_E_TIMEOUT` shall be reported when the timeout supervision of a read, write, erase or compare job failed.] (RS_BRF_01076)

Note: SWS_Fls_00313, SWS_Fls_00314 and SWS_Fls_00361 describe development errors although from their behavior those errors may also occur in a production system. Since erase verification (blankcheck, SWS_Fls_00022, SWS_Fls_00055), write verification (SWS_Fls_00056) and timeout supervision (SWS_Fls_00272, SWS_Fls_00359, SWS_Fls_00360) will have a significant impact on the systems performance and since data consistency in a production system will most likely be ensured by other means (like e.g. checksums, signatures, diagnostic timeouts) it was a design decision from the working group to make these features available only during the development phase (i.e. when development error detection is enabled). This way anyone who wants to use these features (and pay the price) can do so also in a production system by leaving development error detection enabled whilst anyone who doesn't want to have the overhead can simply switch those features off.

7.3 Production Errors

This module does not specify any production errors.

7.4 Runtime Errors

Type or error	Related error code	Value [hex]
Flash erase failed (HW)	FLS E ERASE FAILED	0x01
Flash write failed (HW)	FLS E WRITE FAILED	0x02
Flash read failed (HW)	FLS E READ FAILED	0x03
Flash compare failed (HW)	FLS E COMPARE FAILED	0x04
Expected hardware ID not matched (see SWS_Fls_00144)	FLS_E_UNEXPECTED_FLASH_ID	0x05

[SWS_Fls_00315] [The runtime error code `FLS_E_ERASE_FAILED` shall be reported when the flash erase function failed.] (SRS_BSW_00337, SRS_BSW_00385, SRS_BSW_00327, SRS_BSW_00331)

[SWS_Fls_00316] [The runtime error code `FLS_E_WRITE_FAILED` shall be reported when the flash write function failed.] (SRS_BSW_00337, SRS_BSW_00385, SRS_BSW_00327, SRS_BSW_00331)

[SWS_Fls_00317] [The runtime error code `FLS_E_READ_FAILED` shall be reported when the flash read function failed.] (SRS_BSW_00337, SRS_BSW_00385, SRS_BSW_00327, SRS_BSW_00331)

[SWS_Fls_00318] [The runtime error code `FLS_E_COMPARE_FAILED` shall be reported when the flash compare function failed.] (SRS_BSW_00337, SRS_BSW_00385, SRS_BSW_00327, SRS_BSW_00331)

[SWS_Fls_00319] [The runtime error code `FLS_E_UNEXPECTED_FLASH_ID` shall be reported when the expected flash ID is not matched (see [SWS_Fls_00144](#)).] (SRS_BSW_00337, SRS_BSW_00385, SRS_BSW_00327, SRS_BSW_00331)

7.5 External flash driver

[SWS_Fls_00144] [During the initialization of the external flash driver, the FLS module shall check the hardware ID of the external flash device against the corresponding published parameter. If a hardware ID mismatch occurs, the FLS module shall report the error code `FLS_E_UNEXPECTED_FLASH_ID` to the Default Error Tracer (DET), set the FLS module status to `FLS_E_UNINIT` and shall not initialize itself.] (SRS_Fls_12107)

A complete list of required parameters is specified in the SPI Handler/Driver Software Specification (Chapter “Configuration Specification”, marked as “SPI User”).

7.6 Loading, executing and removing the flash access code

Technical background information: Flash technology or flash memory segmentation may require that the routines that access the flash hardware (internal erase and write routines) are executed from RAM because reading the flash – for instruction fetch needed for code execution – is not allowed while programming the flash.

[SWS_Fls_00137] [The FLS module’s implementer shall place the code of the flash access routines into a separate C-module `Fls_ac.c`.] (SRS_Fls_12193)

[SWS_Fls_00215] [The FLS module’s flash access routines shall only disable interrupts and wait for the completion of the erase / write command if necessary (that is if it has to be ensured that no other code is executed in the meantime).] (SRS_Fls_12194)

[SWS_Fls_00211] [The FLS module’s implementer shall keep the execution time for the flash access code as short as possible.] (SRS_Fls_12194)

[SWS_Fls_00140] [The FLS module’s erase routine shall load the flash access code for erasing the flash memory to the location in RAM pointed to by the erase function pointer contained in the flash drivers configuration set if the FLS module is configured to load the flash access code to RAM on job start.] (SRS_Fls_12193)

[SWS_Fls_00141] [The FLS module's write routine shall load the flash access code for writing the flash memory to the location in RAM pointed to by the write function pointer contained in the flash drivers configuration set if the FLS module is configured to load the flash access code to RAM on job start.] (SRS_Fls_12193)

[SWS_Fls_00212] [The FLS module's main processing routine shall execute the flash access code routines.] (SRS_Fls_12194)

[SWS_Fls_00213] [The FLS module's main processing routine shall access the flash access code routines by means of the respective function pointer contained in the FLS module's configuration set (post-compile parameters) regardless whether the flash access code routines have been loaded to RAM or whether they can be executed directly from (flash) ROM.] (SRS_Fls_12194)

[SWS_Fls_00143] [After an erase or write job has been finished or canceled, the FLS module's main processing routine shall unload (i.e. overwrite) the flash access code (internal erase / write routines) from RAM if they have been loaded to RAM by the flash driver.] (SRS_Fls_13300)

[SWS_Fls_00214] [The FLS module shall only load the access code to the RAM if the access code cannot be executed out of flash ROM.] (SRS_Fls_12193)

7.7 Support for Debugging

[SWS_Fls_00302] {Obsolete} [The module's status, mode and the job result shall be made available for debugging (reading).] (RS_BRF_02240)

8 API specification

8.1 Imported types

[SWS_Fls_00248] [

<i>Module</i>	<i>Imported Type</i>
MemIf	MemIf_JobResultType
	MemIf_ModeType
	MemIf_StatusType
Std_Types	Std_ReturnType
	Std_VersionInfoType

] (SRS_BSW_00392)

8.2 Type definitions

8.2.1 Fls_ConfigType

[SWS_Fls_00368][

Name:	Fls_ConfigType	
Type:	Structure	
Range:	Hardware dependend structure	Structure to hold the flash driver configuration set. The contents of the initialisation data structure are specific to the flash memory hardware.
Description:	A pointer to such a structure is provided to the flash driver initialization routine for configuration of the driver and flash memory hardware.	

] (SRS_BSW_00392)

8.2.2 Fls_AddressType

[SWS_Fls_00369][

Name:	Fls_AddressType		
Type:	uint		
Range:	8 / 16 / 32 bits	--	Size depends on target platform and flash device.
Description:	Used as address offset from the configured flash base address to access a certain flash memory area.		

] (SRS_BSW_00392)

[SWS_Fls_00216] [The type Fls_AddressType shall have 0 as lower limit for each flash device.] (SRS_Fls_12132, SRS_MemHwAb_14005)

[SWS_Fls_00217] [The FLS module shall add a device specific base address to the address type `Fls_AddressType` if necessary.] (SRS_Fls_12132, SRS_MemHwAb_14005)

8.2.3 Fls_LengthType

[SWS_Fls_00370]

Name:	Fls_LengthType	
Type:	uint	
Range:	Same as <code>Fls_AddressType</code>	-- Shall be the same type as <code>Fls_AddressType</code> because of arithmetic operations. Size depends on target platform and flash device.
Description:	Specifies the number of bytes to read/write/erase/compare.	

] (SRS_BSW_00392)

8.3 Function definitions

8.3.1 Fls_Init

[SWS_Fls_00249] [

Service name:	Fls_Init	
Syntax:	<pre>void Fls_Init(const Fls_ConfigType* ConfigPtr)</pre>	
Service ID[hex]:	0x00	
Sync/Async:	Synchronous	
Reentrancy:	Non Reentrant	
Parameters (in):	ConfigPtr	Pointer to flash driver configuration set.
Parameters (inout):	None	
Parameters (out):	None	
Return value:	None	
Description:	Initializes the Flash Driver.	

] (SRS_BSW_00101)

[SWS_Fls_00014] [The function `Fls_Init` shall initialize the FLS module (software) and all flash memory relevant registers (hardware) with parameters provided in the given configuration set.] (SRS_BSW_00404, SRS_BSW_00405, SRS_BSW_00101, SRS_SPAL_12057)

[SWS_Fls_00191] [The function `Fls_Init` shall store the pointer to the given configuration set in a variable in order to allow the FLS module access to the configuration set contents during runtime.] (SRS_BSW_00101)

[SWS_Fls_00086] [The function `Fls_Init` shall initialize all FLS module global variables and those controller registers that are needed for controlling the flash device and that do not influence or depend on other (hardware) modules. Registers that can influence or depend on other modules shall be initialized by a common system module.] (SRS_BSW_00101)

[SWS_Fls_00015] [If development error detection for the module FLS is enabled: the function `Fls_Init` shall check the (hardware specific) contents of the given configuration set for being within the allowed range. If this is not the case, it shall raise the development error `FLS_E_PARAM_CONFIG`.] (SRS_BSW_00323)

[SWS_Fls_00323] [The function `Fls_Init` shall set the FLS module state to `MEMIF_IDLE` after having finished the FLS module initialization.] (SRS_Fls_12143)

[SWS_Fls_00324] [The function `Fls_Init` shall set the flash job result to `MEMIF_JOB_OK` after having finished the FLS module initialization.] (SRS_Fls_12143)

[SWS_Fls_00268] [If development error detection for the module FLS is enabled: the function `Fls_Init` shall check that the FLS module is currently not busy (FLS module state is not `MEMIF_BUSY`). If this check fails, the function `Fls_Init` shall raise the development error `FLS_E_BUSY`.] (SRS_Fls_12143, SRS_BSW_00406)

[SWS_Fls_00048] [If supported by hardware, the function `Fls_Init` shall set the flash memory erase/write protection as provided in the configuration set.] (SRS_Fls_12132)

8.3.2 Fls_Erase

[SWS_Fls_00250] [

Service name:	Fls_Erase	
Syntax:	<pre>Std_ReturnType Fls_Erase(Fls_AddressType TargetAddress, Fls_LengthType Length)</pre>	
Service ID[hex]:	0x01	
Sync/Async:	Asynchronous	
Reentrancy:	Non Reentrant	
Parameters (in):	TargetAddress	Target address in flash memory. This address offset will be added to the flash memory base address. Min.: 0 Max.: <code>FLS_SIZE - 1</code>
	Length	Number of bytes to erase Min.: 1 Max.: <code>FLS_SIZE - TargetAddress</code>
Parameters	None	

(inout):	
Parameters (out):	None
Return value:	Std_ReturnType E_OK: erase command has been accepted E_NOT_OK: erase command has not been accepted
Description:	Erases flash sector(s).

] (SRS_Fls_12136)

[SWS_Fls_00218] [The job of the function `Fls_Erase` shall erase one or more complete flash sectors.] (SRS_Fls_12136)

[SWS_Fls_00327] [The function `Fls_Erase` shall copy the given parameters to FLS module internal variables and initiate an erase job.] (SRS_Fls_12136)

[SWS_Fls_00328] [After initiating the erase job, the function `Fls_Erase` shall set the FLS module status to `MEMIF_BUSY`.] (SRS_Fls_12136)

[SWS_Fls_00329] [After initiating the erase job, the function `Fls_Erase` shall set the job result to `MEMIF_JOB_PENDING`.] (SRS_Fls_12136)

[SWS_Fls_00330] [After initiating the erase job, the function `Fls_Erase` shall return with `E_OK`.] (SRS_Fls_12136)

[SWS_Fls_00220] [The FLS module shall execute the job of the function `Fls_Erase` asynchronously within the FLS module's main function.] (SRS_Fls_12136, SRS_Fls_12144)

[SWS_Fls_00221] [The job of the function `Fls_Erase` shall erase a flash memory block starting from `FlsBaseAddress + TargetAddress` of size `Length`.

Note: `Length` will be rounded up to the next full sector boundary since only complete flash sectors can be erased.] (SRS_Fls_12136)

[SWS_Fls_00020] [If development error detection for the module FLS is enabled: the function `Fls_Erase` shall check that the erase start address (`FlsBaseAddress + TargetAddress`) is aligned to a flash sector boundary and that it lies within the specified lower and upper flash address boundaries. If this check fails, the function `Fls_Erase` shall reject the erase request, raise the development error `FLS_E_PARAM_ADDRESS` and return with `E_NOT_OK`.] (SRS_BSW_00323, SRS_Fls_12136, SRS_Fls_12159)

[SWS_Fls_00021] [If development error detection for the module FLS is enabled: the function `Fls_Erase` shall check that the erase length is greater than 0 and that the erase end address (erase start address + length) is aligned to a flash sector boundary and that it lies within the specified upper flash address boundary. If this check fails, the function `Fls_Erase` shall reject the erase request, raise the

development error `FLS_E_PARAM_LENGTH` and return with `E_NOT_OK`.] (SRS_BSW_00323, SRS_Fls_12136, SRS_Fls_12159)

[SWS_Fls_00065] [If development error detection for the module FLS is enabled: the function `Fls_Erase` shall check that the FLS module has been initialized. If this check fails, the function `Fls_Erase` shall reject the erase request, raise the development error `FLS_E_UNINIT` and return with `E_NOT_OK`.] (SRS_BSW_00406)

[SWS_Fls_00023] [If development error detection for the module FLS is enabled: the function `Fls_Erase` shall check that the FLS module is currently not busy. If this check fails, the function `Fls_Erase` shall reject the erase request, raise the development error `FLS_E_BUSY` and return with `E_NOT_OK`.] (SRS_Fls_12143)

[SWS_Fls_00145] [If possible, e.g. with interrupt controlled implementations, the FLS module shall start the first round of the erase job directly within the function `Fls_Erase` to reduce overall runtime.] (SRS_Fls_12136)

8.3.3 Fls_Write

[SWS_Fls_00251] [

Service name:	Fls_Write	
Syntax:	<pre>Std_ReturnType Fls_Write(Fls_AddressType TargetAddress, const uint8* SourceAddressPtr, Fls_LengthType Length)</pre>	
Service ID[hex]:	0x02	
Sync/Async:	Asynchronous	
Reentrancy:	Non Reentrant	
Parameters (in):	TargetAddress	Target address in flash memory. This address offset will be added to the flash memory base address. Min.: 0 Max.: <code>FLS_SIZE - 1</code>
	SourceAddressPtr	Pointer to source data buffer
	Length	Number of bytes to write Min.: 1 Max.: <code>FLS_SIZE - TargetAddress</code>
Parameters (inout):	None	
Parameters (out):	None	
Return value:	Std_ReturnType	<code>E_OK</code> : write command has been accepted <code>E_NOT_OK</code> : write command has not been accepted
Description:	Writes one or more complete flash pages.	

] (SRS_Fls_12135)

[SWS_Fls_00223] [The job of the function `Fls_Write` shall write one or more complete flash pages to the flash device.] (SRS_Fls_12135)

[SWS_Fls_00331] [The function `Fls_Write` shall copy the given parameters to Fls module internal variables and initiate a write job.] (SRS_Fls_12135)

[SWS_Fls_00332] [After initiating the write job, the function `Fls_Write` shall set the FLS module status to `MEMIF_BUSY`.] (SRS_Fls_12135)

[SWS_Fls_00333] [After initiating the write job, the function `Fls_Write` shall set the job result to `MEMIF_JOB_PENDING`.] (SRS_Fls_12135)

[SWS_Fls_00334] [After initiating the write job, the function `Fls_Write` shall return with `E_OK`.] (SRS_Fls_12135)

[SWS_Fls_00225] [The FLS module shall execute the write job of the function `Fls_Write` asynchronously within the FLS module's main function.] (SRS_Fls_12135, SRS_Fls_12144)

[SWS_Fls_00226] [The job of the function `Fls_Write` shall program a flash memory block with data provided via `SourceAddressPtr` starting from `FlsBaseAddress + TargetAddress` of size `Length`.] (SRS_Fls_12135)

[SWS_Fls_00026] [If development error detection for the module Fls is enabled: the function `Fls_Write` shall check that the write start address (`FlsBaseAddress + TargetAddress`) is aligned to a flash page boundary and that it lies within the specified lower and upper flash address boundaries. If this check fails, the function `Fls_Write` shall reject the write request, raise the development error `FLS_E_PARAM_ADDRESS` and return with `E_NOT_OK`.] (SRS_BSW_00323, SRS_Fls_12135, SRS_Fls_12159)

[SWS_Fls_00027] [If development error detection for the module Fls is enabled: the function `Fls_Write` shall check that the write length is greater than 0, that the write end address (write start address + length) is aligned to a flash page boundary and that it lies within the specified upper flash address boundary. If this check fails, the function `Fls_Write` shall reject the write request, raise the development error `FLS_E_PARAM_LENGTH` and return with `E_NOT_OK`.] (SRS_BSW_00323, SRS_Fls_12135, SRS_Fls_12159)

[SWS_Fls_00066] [If development error detection for the module Fls is enabled: the function `Fls_Write` shall check that the FLS module has been initialized. If this check fails, the function `Fls_Write` shall reject the write request, raise the development error `FLS_E_UNINIT` and return with `E_NOT_OK`.] (SRS_BSW_00406)

[SWS_Fls_00030] [If development error detection for the module Fls is enabled: the function `Fls_Write` shall check that the FLS module is currently not busy. If this check fails, the function `Fls_Write` shall reject the write request, raise the development error `FLS_E_BUSY` and return with `E_NOT_OK`.] (SRS_Fls_12143)

[SWS_Fls_00157] [If development error detection for the module Fls is enabled: the function `Fls_Write` shall check the given data buffer pointer for not being a null pointer. If the data buffer pointer is a null pointer, the function `Fls_Write` shall reject the write request, raise the development error `FLS_E_PARAM_DATA` and return with `E_NOT_OK`.] (SRS_BSW_00323)

[SWS_Fls_00146] [If possible, e.g. with interrupt controlled implementations, the FLS module shall start the first round of the write job directly within the function `Fls_Write` to reduce overall runtime.] (SRS_Fls_12135)

8.3.4 Fls_Cancel

[SWS_Fls_00252] [

Service name:	Fls_Cancel
Syntax:	<pre>void Fls_Cancel(void)</pre>
Service ID[hex]:	0x03
Sync/Async:	Synchronous
Reentrancy:	Non Reentrant
Parameters (in):	None
Parameters (inout):	None
Parameters (out):	None
Return value:	None
Description:	Cancels an ongoing job.

] (SRS_Fls_12137)

[SWS_Fls_00229] [The function `Fls_Cancel` shall cancel an ongoing flash read, write, erase or compare job.] (SRS_Fls_12137)

[SWS_Fls_00230] [The function `Fls_Cancel` shall abort a running job synchronously so that directly after returning from this function a new job can be started.] (SRS_Fls_12137)

Note: The function `Fls_Cancel` is synchronous in its behaviour but at the same time asynchronous w.r.t. the underlying hardware: The job of the `Fls_Cancel` function (i.e. make the module ready for a new job request) is finished when it returns to the caller (hence it's synchronous) but on the other hand e.g. an erase job might still be ongoing in the hardware device (hence it's asynchronous w.r.t. the hardware).

[SWS_Fls_00335] [The function `Fls_Cancel` shall reset the FLS module's internal job processing variables (like address, length and data pointer).] (SRS_Fls_12137)

[SWS_Fls_00336] [The function `Fls_Cancel` shall set the FLS module state to `MEMIF_IDLE`.] (SRS_Fls_12137)

[SWS_Fls_00033] [The function `Fls_Cancel` shall set the job result to `MEMIF_JOB_CANCELED` if the job result currently has the value `MEMIF_JOB_PENDING`. Otherwise the function `Fls_Cancel` shall leave the job result unchanged.] (SRS_Fls_12137, SRS_Fls_12143)

[SWS_Fls_00147] [If configured, the function `Fls_Cancel` shall call the error notification function to inform the caller about the cancellation of a job.] (RS_BRF_01064)

Note: The content of the affected flash memory cells will be undefined when canceling an ongoing job with the function `Fls_Cancel`.

[SWS_Fls_00183] [The function `Fls_Cancel` shall be pre-compile time configurable `On/Off` by the configuration parameter `FlsCancelApi`.] (SRS_BSW_00171, SRS_Fls_12137)

[SWS_Fls_00356] [If development error detection for the module FLS is enabled: the function `Fls_Cancel` shall check that the FLS module has been initialized. If this check fails, the function `Fls_Cancel` shall raise the development error `FLS_E_UNINIT` and return.] (SWS_BSW_00406)

8.3.5 Fls_GetStatus

[SWS_Fls_00253] [

Service name:	Fls_GetStatus	
Syntax:	MemIf_StatusType Fls_GetStatus(void)	
Service ID[hex]:	0x04	
Sync/Async:	Synchronous	
Reentrancy:	Reentrant	
Parameters (in):	None	
Parameters (inout):	None	
Parameters (out):	None	
Return value:	MemIf_StatusType	--
Description:	Returns the driver state.	

] (SRS_Fls_12138)

[SWS_Fls_00034] [The function `Fls_GetStatus` shall return the FLS module state synchronously.] (SRS_Fls_12138)

[SWS_Fls_00184] [The function `Fls_GetStatus` shall be pre-compile time configurable On/Off by the configuration parameter `FlsGetStatusApi`.] (SRS_Fls_12138, SRS_BSW_00171)

Note: The function `Fls_GetStatus` may be called before the module has been initialized in which case it shall return `MEMIF_UNINIT`.

8.3.6 Fls_GetJobResult

[SWS_Fls_00254] [

Service name:	Fls_GetJobResult	
Syntax:	MemIf_JobResultType Fls_GetJobResult(void)	
Service ID[hex]:	0x05	
Sync/Async:	Synchronous	
Reentrancy:	Reentrant	
Parameters (in):	None	
Parameters (inout):	None	
Parameters (out):	None	
Return value:	MemIf_JobResultType	--
Description:	Returns the result of the last job.	

] (SRS_Fls_12134, SRS_Fls_12135, SRS_Fls_12136, SRS_SWS_12137)

[SWS_Fls_00035] [The function `Fls_GetJobResult` shall return the result of the last job synchronously] (SRS_Fls_12134, SRS_Fls_12135, SRS_Fls_12136, SRS_SWS_12137)

[SWS_Fls_00036] [The erase, write, read and compare functions shall share the same job result, i.e. only the result of the last job can be queried. The FLS module shall overwrite the job result with `MEMIF_JOB_PENDING` if the FLS module has accepted a new job.] (SRS_Fls_12143)

[SWS_Fls_00185] [The function `Fls_GetJobResult` shall be pre-compile time configurable On/Off by the configuration parameter `FlsGetJobResultApi`.] (SRS_BSW_00171)

[SWS_Fls_00358] [If development error detection for the module Fls is enabled: the function `Fls_GetJobResult` shall check that the FLS module has been initialized. If this check fails, the function `Fls_GetJobResult` shall raise the development error `FLS_E_UNINIT` and return with `MEMIF_JOB_FAILED`.] (SRS_BSW_00406)

8.3.7 Fls_Read

[SWS_Fls_00256] [

Service name:	Fls_Read	
Syntax:	<pre>Std_ReturnType Fls_Read(Fls_AddressType SourceAddress, uint8* TargetAddressPtr, Fls_LengthType Length)</pre>	
Service ID[hex]:	0x07	
Sync/Async:	Asynchronous	
Reentrancy:	Non Reentrant	
Parameters (in):	SourceAddress	Source address in flash memory. This address offset will be added to the flash memory base address. Min.: 0 Max.: FLS_SIZE - 1
	Length	Number of bytes to read Min.: 1 Max.: FLS_SIZE - SourceAddress
Parameters (inout):	None	
Parameters (out):	TargetAddressPtr	Pointer to target data buffer
Return value:	Std_ReturnType	E_OK: read command has been accepted E_NOT_OK: read command has not been accepted
	Description: Reads from flash memory.	

] (SRS_Fls_12134)

[SWS_Fls_00236] [The function `Fls_Read` shall read from flash memory.] (SRS_Fls_12134)

[SWS_Fls_00337] [The function `Fls_Read` shall copy the given parameters to FLS module internal variables and initiate a read job.] (SRS_Fls_12134)

[SWS_Fls_00338] [After initiating a read job, the function `Fls_Read` shall set the FLS module status to `MEMIF_BUSY`.] (SRS_Fls_12134)

[SWS_Fls_00339] [After initiating a read job, the function `Fls_Read` shall set the FLS module job result to `MEMIF_JOB_PENDING`.] (SRS_Fls_12134)

[SWS_Fls_00340] [After initiating a read job, the function `Fls_Read` shall return with `E_OK`.] (SRS_Fls_12134)

[SWS_Fls_00238] [The FLS module shall execute the read job of the function `Fls_Read` asynchronously within the FLS module's main function.] (SRS_Fls_12134, SRS_Fls_12144)

[SWS_Fls_00239] [The read job of the function `Fls_Read` shall copy a continuous flash memory block starting from `FlsBaseAddress + SourceAddress` of size `Length` to the buffer pointed to by `TargetAddressPtr`.] (SRS_Fls_12134)

[SWS_Fls_00097] [If development error detection for the module FLS is enabled: the function `Fls_Read` shall check that the read start address (`FlsBaseAddress + SourceAddress`) lies within the specified lower and upper flash address boundaries. If this check fails, the function `Fls_Read` shall reject the read job, raise development error `FLS_E_PARAM_ADDRESS` and return with `E_NOT_OK`.] (SRS_BSW_00323, SRS_Fls_12134, SRS_Fls_12159)

[SWS_Fls_00098] [If development error detection for the module FLS is enabled: the function `Fls_Read` shall check that the read length is greater than 0 and that the read end address (read start address + length) lies within the specified upper flash address boundary. If this check fails, the function `Fls_Read` shall reject the read job, raise the development error `FLS_E_PARAM_LENGTH` and return with `E_NOT_OK`.] (SRS_BSW_00323, SRS_Fls_12134, SRS_Fls_12159)

[SWS_Fls_00099] [If development error detection for the module FLS is enabled: the function `Fls_Read` shall check that the driver has been initialized. If this check fails, the function `Fls_Read` shall reject the read request, raise the development error `FLS_E_UNINIT` and return with `E_NOT_OK`.] (SRS_BSW_00406)

[SWS_Fls_00100] [If development error detection for the module FLS is enabled: the function `Fls_Read` shall check that the driver is currently not busy. If this check fails, the function `Fls_Read` shall reject the read request, raise the development error `FLS_E_BUSY` and return with `E_NOT_OK`.] (SRS_Fls_12143)

[SWS_Fls_00158] [If development error detection for the module FLS is enabled: the function `Fls_Read` shall check the given data buffer pointer for not being a null pointer. If the data buffer pointer is a null pointer, the function `Fls_Read` shall reject the read request, raise the development error `FLS_E_PARAM_DATA` and return with `E_NOT_OK`.] (SRS_Fls_00323)

[SWS_Fls_00240] [The FLS module's environment shall only call the function `Fls_Read` after the FLS module has been initialized.] (SRS_BSW_00406)

8.3.8 Fls_Compare

[SWS_Fls_00257] [

Service name:	<code>Fls_Compare</code>
Syntax:	<code>Std_ReturnType Fls_Compare(</code>

	<pre>Fls_AddressType SourceAddress, const uint8* TargetAddressPtr, Fls_LengthType Length) </pre>	
Service ID[hex]:	0x08	
Sync/Async:	Asynchronous	
Reentrancy:	Non Reentrant	
Parameters (in):	SourceAddress	Source address in flash memory. This address offset will be added to the flash memory base address. Min.: 0 Max.: FLS_SIZE - 1
	TargetAddressPtr	Pointer to target data buffer
	Length	Number of bytes to compare Min.: 1 Max.: FLS_SIZE - SourceAddress
Parameters (inout):	None	
Parameters (out):	None	
Return value:	Std_ReturnType	E_OK: compare command has been accepted E_NOT_OK: compare command has not been accepted
Description:	Compares the contents of an area of flash memory with that of an application data buffer.	

] (SRS_Fls_13301)

[SWS_Fls_00241] [The function `Fls_Compare` shall compare the contents of an area of flash memory with that of an application data buffer.] (SRS_Fls_13301)

[SWS_Fls_00341] [The function `Fls_Compare` shall copy the given parameters to Fls module internal variables and initiate a compare job.] (SRS_Fls_13301)

[SWS_Fls_00342] [After initiating the compare job, the function `Fls_Compare` shall set the status to `MEMIF_BUSY`.] (SRS_Fls_13301)

[SWS_Fls_00343] [After initiating the compare job, the function `Fls_Compare` shall set the job result to `MEMIF_JOB_PENDING`.] (SRS_Fls_13301)

[SWS_Fls_00344] [After initiating the compare job, the function `Fls_Compare` shall return with `E_OK`.] (SRS_Fls_13301)

[SWS_Fls_00243] [The FLS module shall execute the job of the function `Fls_Compare` asynchronously within the FLS module's main function.] (SRS_Fls_13301, SRS_Fls_12144)

[SWS_Fls_00244] [The job of the function `Fls_Compare` shall compare a continuous flash memory block starting from `FlsBaseAddress + SourceAddress` of size `Length` with the buffer pointed to by `TargetAddressPtr`.] (SRS_Fls_13301)

[SWS_Fls_00150] [If development error detection for the module Fls is enabled: the function `Fls_Compare` shall check that the compare start address

(FlsBaseAddress + SourceAddress) lies within the specified lower and upper flash address boundaries. If this check fails, the function `Fls_Compare` shall reject the compare job, raise the development error `FLS_E_PARAM_ADDRESS` and return with `E_NOT_OK.`] (SRS_Fls_13301)

[SWS_Fls_00151] [If development error detection for the module Fls is enabled: the function `Fls_Compare` shall check that the given length is greater than 0 and that the compare end address (compare start address + length) lies within the specified upper flash address boundary. If this check fails, the function `Fls_Compare` shall reject the compare job, raise the development error `FLS_E_PARAM_LENGTH` and return with `E_NOT_OK.`] (SRS_Fls_13301)

[SWS_Fls_00152] [If development error detection for the module Fls is enabled: the function `Fls_Compare` shall check that the driver has been initialized. If this check fails, the function `Fls_Compare` shall reject the compare job, raise the development error `FLS_E_UNINIT` and return with `E_NOT_OK.`] (SRS_Fls_13301)

[SWS_Fls_00153] [If development error detection for the module Fls is enabled: the function `Fls_Compare` shall check that the driver is currently not busy. If this check fails, the function `Fls_Compare` shall reject the compare job, raise the development error `FLS_E_BUSY` and return with `E_NOT_OK.`] (SRS_Fls_13301)

[SWS_Fls_00273] [If development error detection for the module Fls is enabled: the function `Fls_Compare` shall check the given data buffer pointer for not being a null pointer. If the data buffer pointer is a null pointer, the function `Fls_Compare` shall reject the request, raise the development error `FLS_E_PARAM_DATA` and return with `E_NOT_OK.`] (RS_BRF_01064)

[SWS_Fls_00186] [The function `Fls_Compare` shall be pre-compile time configurable On/Off by the configuration parameter `FlsCompareApi.`] (SRS_BSW_00171, SRS_Fls_13301)

8.3.9 Fls_SetMode

[SWS_Fls_00258] [

Service name:	Fls_SetMode	
Syntax:	void Fls_SetMode(MemIf_ModeType Mode)	
Service ID[hex]:	0x09	
Sync/Async:	Synchronous	
Reentrancy:	Non Reentrant	
Parameters (in):	Mode	MEMIF_MODE_SLOW: Slow read access / normal SPI access. MEMIF_MODE_FAST: Fast read access / SPI burst access.

Parameters (inout):	None
Parameters (out):	None
Return value:	None
Description:	Sets the flash driver's operation mode.

] (SRS_Fls_13302)

[SWS_Fls_00155] [The function `Fls_SetMode` shall set the FLS module's operation mode to the given "Mode" parameter.] (SRS_Fls_13302)

[SWS_Fls_00156] [If development error detection for the module `Fls` is enabled: the function `Fls_SetMode` shall check that the FLS module is currently not busy. If this check fails, the function `Fls_SetMode` shall reject the set mode request and raise the development error code `FLS_E_BUSY`.] (SRS_Fls_13302)

[SWS_Fls_00187] [The function `Fls_SetMode` shall be pre-compile time configurable `On/Off` by the configuration parameter `FlsSetModeApi`.] (SRS_BSW_00171, SRS_Fls_13302)

8.3.10 Fls_GetVersionInfo

[SWS_Fls_00259] [

Service name:	Fls_GetVersionInfo	
Syntax:	<pre>void Fls_GetVersionInfo(Std_VersionInfoType* VersionInfoPtr)</pre>	
Service ID[hex]:	0x10	
Sync/Async:	Synchronous	
Reentrancy:	Reentrant	
Parameters (in):	None	
Parameters (inout):	None	
Parameters (out):	VersionInfoPtr	Pointer to where to store the version information of this module.
Return value:	None	
Description:	Returns the version information of this module.	

] (SRS_BSW_00407)

[SWS_Fls_00363][If development error detection for the module `Fls` is enabled: the function `Fls_GetVersionInfo` shall raise the development error `FLS_E_PARAM_POINTER` if the argument is a NULL pointer and return without any action.] (SRS_BSW_00323)

8.3.11 Fls_BlankCheck

[SWS_Fls_00371]

Service name:	Fls_BlankCheck	
Syntax:	Std_ReturnType Fls_BlankCheck(Fls_AddressType TargetAddress, Fls_LengthType Length)	
Service ID[hex]:	0x0a	
Sync/Async:	Asynchronous	
Reentrancy:	Non Reentrant	
Parameters (in):	TargetAddress	Address in flash memory from which the blank check should be started. Min.: 0 Max.: FLS_SIZE - 1
	Length	Number of bytes to be checked for erase pattern. Min.: 1 Max.: FLS_SIZE - TargetAddress
Parameters (inout):	None	
Parameters (out):	None	
Return value:	Std_ReturnType	E_OK: request for blank checking has been accepted by the module E_NOT_OK: request for blank checking has not been accepted by the module
Description:	The function Fls_BlankCheck shall verify, whether a given memory area has been erased but not (yet) programmed. The function shall limit the maximum number of checked flash cells per main function cycle to the configured value FlsMaxReadNormalMode or FlsMaxReadFastMode respectively.	

(RS_BRF_01076)

[SWS_Fls_00373] [The function Fls_BlankCheck shall verify, whether a given memory area has been erased but not (yet) re-programmed.] (RS_BRF_01076)

[SWS_Fls_00374] [The function Fls_BlankCheck shall copy the given parameters to FLS module internal variables and initiate the verification job.] (SRS_Fls_12144)

[SWS_Fls_00375] [After initiating the verification job, the function Fls_BlankCheck shall set the FLS module status to MEMIF_BUSY.] (SRS_Fls_12144)

[SWS_Fls_00376] [After initiating the verification job, the function Fls_BlankCheck shall set the FLS module job result to MEMIF_JOB_PENDING.] (SRS_Fls_12144)

[SWS_Fls_00377] [After initiating the verification job, the function Fls_BlankCheck shall return with E_OK.] (SRS_Fls_12144)

[SWS_Fls_00378] [The FLS module shall execute the verification job of the function `Fls_BlankCheck` asynchronously within the FLS module's main function.]
(SRS_Fls_12144)

[SWS_Fls_00379] [The verification job of the function `Fls_BlankCheck` shall check, that the continuous flash memory area starting from `FlsBaseAddress + TargetAddress` of size `Length` is erased.] **(SRS_Fls_12144)**

[SWS_Fls_00380] [If development error detection for the module FLS is enabled; the function `Fls_BlankCheck` shall check that the verification start address (`FlsBaseAddress + TargetAddress`) lies within the specified lower and upper flash address boundaries. If this check fails, the function `Fls_BlankCheck` shall reject the verification job, raise the development error `FLS_E_PARAM_ADDRESS` and return with `E_NOT_OK`.] **(SRS_Fls_12159)**

[SWS_Fls_00381] [If development error detection for the module FLS is enabled: the function `Fls_BlankCheck` shall check that the given length is greater than 0 and that the verification end address (verification start address + length) lies within the specified upper flash address boundary. If this check fails, the function `Fls_BlankCheck` shall reject the verification job, raise the development error `FLS_E_PARAM_LENGTH` and return with `E_NOT_OK`.] **(SRS_Fls_12159)**

[SWS_Fls_00382] [If development error detection for the module FLS is enabled: the function `Fls_BlankCheck` shall check that the driver has been initialized. If this check fails, the function `Fls_BlankCheck` shall reject the verification request, raise the development error `FLS_E_UNINIT` and return with `E_NOT_OK`.]
(SRS_BSW_00406)

[SWS_Fls_00383] [If development error detection for the module FLS is enabled: the function `Fls_BlankCheck` shall check that the driver is currently not busy. If this check fails, the function `Fls_BlankCheck` shall reject the verification request, raise the development error `FLS_E_BUSY` and return with `E_NOT_OK`.]
(SRS_BSW_00406)

8.4 Call-back notifications

This chapter lists all functions provided by the FLS module to lower layer modules.

Note: There are no callback functions to lower layer modules provided by the Flash Driver since this module is at the lowest (software) layer.

[SWS_Fls_00193] [Depending on implementation, callback routines provided and/or invoked by the FLS module may be called on interrupt level. The module providing those routines has therefore to make sure that their runtime is reasonably short, i.e.

since callbacks may be propagated upward through several software layers.]
(SRS_BSW_00164, SRS_BSW_00325)

8.5 Scheduled functions

This chapter lists all functions provided by the Fls module and called directly by the Basic Software Module Scheduler.

[SWS_Fls_00269] [The Fls module shall provide only one scheduled function. Reading from / writing to flash memory cannot usually be done simultaneously and the overhead for synchronizing two scheduled functions would outweigh the benefits.] (SRS_BSW_00432)

8.5.1 Fls_MainFunction

[SWS_Fls_00255] [

Service name:	Fls_MainFunction
Syntax:	void Fls_MainFunction(void)
Service ID[hex]:	0x06
Description:	Performs the processing of jobs.

] (SRS_Fls_12144)

[SWS_Fls_00037] [The function `Fls_MainFunction` shall perform the processing of the flash read, write, erase and compare jobs.] (SRS_Fls_12144)

[SWS_Fls_00038] [When a job has been initiated, the FLS module's environment shall call the function `Fls_MainFunction` cyclically until the job is finished.] (SRS_Fls_12144)

Note: The function `Fls_MainFunction` may also be called cyclically if no job is currently pending.

[SWS_Fls_00039] [The function `Fls_MainFunction` shall return without any action if no job is pending.] (SRS_Fls_12144)

[SWS_Fls_00040] [The function `Fls_MainFunction` shall only process as much data in one call cycle as statically configured for the current job type (read, write or compare) and the current FLS module's operating mode (normal, fast).] (SRS_Fls_13303, SRS_Fls_13304, SRS_Fls_12145, SRS_Fls_12184)

[SWS_Fls_00104] [The function `Fls_MainFunction` shall set the job result to `MEMIF_JOB_FAILED` and report the error code `FLS_E_ERASE_FAILED` to the DET

if a flash erase job fails due to a hardware error.] (SRS_BSW_00339, SRS_BSW_00385, SRS_BSW_00466)

[SWS_Fls_00105] [The function `Fls_MainFunction` shall set the job result to `MEMIF_JOB_FAILED` and report the error code `FLS_E_WRITE_FAILED` to the DET if a flash write job fails due to a hardware error.] (SRS_BSW_00339, SRS_BSW_00385, SRS_BSW_00466)

[SWS_Fls_00106] [The function `Fls_MainFunction` shall set the job result to `MEMIF_JOB_FAILED` and report the error code `FLS_E_READ_FAILED` to the DET if a flash read job fails due to a hardware error.] (SRS_BSW_00339, SRS_BSW_00385, SRS_BSW_00466)

[SWS_Fls_00154] [The function `Fls_MainFunction` shall set the job result to `MEMIF_JOB_FAILED` and report the error code `FLS_E_COMPARE_FAILED` to the DET if a flash compare job fails due to a hardware error.] (SRS_BSW_00339, SRS_BSW_00385, SRS_BSW_00466)

[SWS_Fls_00200] [The function `Fls_MainFunction` shall set the job result to `MEMIF_BLOCK_INCONSISTENT` if the compared data from a flash compare job are not equal.] (SRS_Fls_12141)

[SWS_Fls_00022] [If development error detection for the module `Fls` is enabled: After a flash block has been erased, the function `Fls_MainFunction` shall compare the contents of the addressed memory area against the value of an erased flash cell to check that the block has been completely erased. If this check fails, the function `Fls_MainFunction` shall set the FLS module's job result to `MEMIF_JOB_FAILED` and raise development error `FLS_E_VERIFY_ERASE_FAILED`.] (SRS_Fls_12160)

[SWS_Fls_00055] [If development error detection for the module `Fls` is enabled: Before writing a flash block, the function `Fls_MainFunction` shall compare the contents of the addressed memory area against the value of an erased flash cell to check that the block has been completely erased. If this check fails, the function `Fls_MainFunction` shall set the FLS module's job result to `MEMIF_JOB_FAILED` and raise development error `FLS_E_VERIFY_ERASE_FAILED`.] (SRS_Fls_12158)

[SWS_Fls_00056] [If development error detection for the module `Fls` is enabled: After writing a flash block, the function `Fls_MainFunction` shall compare the contents of the reprogrammed memory area against the contents of the provided application buffer to check that the block has been completely reprogrammed. If this check fails, the function `Fls_MainFunction` shall set the FLS module's job result to `MEMIF_JOB_FAILED` and raise the development error `FLS_E_VERIFY_WRITE_FAILED`.] (SRS_Fls_12141)

[SWS_Fls_00345] [After a read, erase, write or compare job has been finished, the function `Fls_MainFunction` shall set the FLS module's job result to

MEMIF_JOB_OK if it is currently in state MEMIF_JOB_PENDING. Otherwise, it shall leave the result unchanged.] (SRS_Fls_12144)

[SWS_Fls_00346] [After a read, erase, write or compare job has been finished, the function `Fls_MainFunction` shall set the FLS module's state to `MEMIF_IDLE` and call the job end notification function if configured (see [ECUC Fls 00307](#)).] (SRS_Fls_12144)

[SWS_Fls_00232] [The configuration parameter `FlsUseInterrupts` shall switch between interrupt and polling controlled job processing if this is supported by the flash memory hardware.] (SRS_BSW_00164)

[SWS_Fls_00233] [The FLS module's implementer shall locate the interrupt service routine in `Fls_Irq.c`.] (RS_BRF_01144)

[SWS_Fls_00234] [If interrupt controlled job processing is supported and enabled with the configuration parameter `FlsUseInterrupts`, the interrupt service routine shall reset the interrupt flag, check for errors reported by the underlying hardware, reload the hardware finite state machine for the next round of the pending job or call the appropriate notification routine if the job is finished or aborted.] (RS_BRF_01144)

[SWS_Fls_00235] [The function `Fls_MainFunction` shall process jobs without hardware interrupt support (e.g. read jobs).] (SRS_Fls_12144)

[SWS_Fls_00272] [If development error detection for the module FLS is enabled: the function `Fls_MainFunction` shall provide a timeout monitoring for the currently running job, that is it shall supervise the deadline of the read / compare / erase or write job.] (SRS_Fls_12144, RS_BRF_01076)

[SWS_Fls_00359] [If development error detection for the module FLS is enabled: the function `Fls_MainFunction` shall check, whether the configured maximum erase time (see [ECUC Fls 00298](#) `FlsEraseTime`) has been exceeded. If this is the case, the function `Fls_MainFunction` shall raise the development error `FLS_E_TIMEOUT`.] (RS_BRF_01076)

[SWS_Fls_00360] [If development error detection for the module FLS is enabled: the function `Fls_MainFunction` shall check, whether the expected maximum write time (see note below) has been exceeded. If this is the case, the function `Fls_MainFunction` shall raise the development error `FLS_E_TIMEOUT`.] (RS_BRF_01076)

Note: The expected maximum write time depends on the current mode of the FLS module (see [SWS Fls 00258](#)), the configured number of bytes to write in this mode (see [ECUC Fls 00278](#) and [ECUC Fls 00277](#) respectively), the size of a single flash page (see [ECUC Fls 00281](#)) and last the maximum time to write one flash page (see [ECUC Fls 00301](#)). The number of bytes to write divided by the size of one

flash page yields the number of pages to write in one cycle. This multiplied with the maximum write time for one flash page gives you the expected maximum write time.

[SWS_Fls_00362] [If development error detection for the module Fls is enabled: the function `Fls_MainFunction` shall check, whether the expected maximum read / compare time (see note below) has been exceeded. If this is the case, the function `Fls_MainFunction` shall raise the development error `FLS_E_TIMEOUT`.] (RS_BRF_01076)

Note: There are no published timings for read / compare (these would mostly depend on whether the flash device is internal or external e.g. connected via SPI). The solution would be similar as for write jobs above: the configured number of bytes to read (and to compare) is coupled to the expected read / compare times which should be supervised by the `Fls_MainFunction`. If this is not detailed enough there are two possibilities:

- *specify expected read / compare times (difficult because of the dependency mentioned above)*
- *leave read / compare jobs out of the timeout supervision (change `SWS_Fls_00272`).*

[SWS_Fls_00117] [If development error detection for the module Fls is enabled: the function `Fls_MainFunction` shall check that the FLS module has been initialized. If this check fails, the function `Fls_MainFunction` shall raise the development error `FLS_E_UNINIT`.] (SRS_BSW_00406)

[SWS_Fls_00196] [The function `Fls_MainFunction` shall at the most issue one sector erase command (to the hardware) in each cycle.] (SRS_Fls_12144)

Note: The requirement above shall ensure that maximum one sector is erased sequentially within one cycle of the driver's main function. If the hardware is capable of erasing more than one sector in parallel, this shall not be restricted by this specification.

8.6 Expected Interfaces

This chapter lists all functions the Fls module requires from other modules.

8.6.1 Mandatory Interfaces

This chapter defines all interfaces which are required to fulfill the core functionality of the module.

[SWS_Fls_00260] [

API function	Description
--------------	-------------

] (SRS_BSW_00469, SRS_BSW_00339)

Note: If the flash device is connected via SPI, also the SPI interfaces are required to fulfill the modules core functionality. Which interfaces are needed exactly shall not be detailed further in this specification.

8.6.2 Optional Interfaces

This chapter defines all interfaces which are required to fulfill an optional functionality of the module.

[SWS_Fls_00261] [

API function	Description
Det_ReportError	Service to report development errors.

] (SRS_BSW_00442)

8.6.3 Configurable interfaces

In this chapter, all interfaces are listed for which the target function can be configured. The target function is usually a call-back function. The names of these kind of interfaces is not fixed because they are configurable.

[SWS_Fls_00109] [The job processing callback notifications shall be configurable as function pointers within the initialization data structure (Fls_ConfigType).] (SRS_BSW_00387)

[SWS_Fls_00110] [The callback notifications shall have no parameters and no return value.] (SRS_BSW_00387)

[SWS_Fls_00262] [

Service name:	Fee_JobEndNotification
Syntax:	void Fee_JobEndNotification(void)
Sync/Async:	Synchronous
Reentrancy:	Don't care
Parameters (in):	None
Parameters (inout):	None
Parameters (out):	None
Return value:	None
Description:	This callback function is called when a job has been completed with a positive result.

] (RS_BRF_01064, SRS_BSW_00387)

[SWS_Fls_00167] [The FLS module shall call the callback function `Fee_JobEndNotification` when the module has completed a job with a positive result:

- Read job finished & OK
- Write job finished & OK
- Erase job finished & OK
- Compare job finished & memory blocks are the same] (RS_BRF_01064, SRS_BSW_00387)

[SWS_Fls_00263] [

Service name:	Fee_JobErrorNotification
Syntax:	void Fee_JobErrorNotification(void)
Sync/Async:	Synchronous
Reentrancy:	Don't care
Parameters (in):	None
Parameters (inout):	None
Parameters (out):	None
Return value:	None
Description:	This callback function is called when a job has been canceled or finished with negative result.

] (RS_BRF_01064, SRS_BSW_00387)

[SWS_Fls_00347] [The FLS module shall call the callback function `Fee_JobErrorNotification` when the module has finished a job with a negative result:

- Read job failed
- Write job failed
- Erase job failed
- Compare job failed] (SRS_BSW_00387)

[SWS_Fls_00348] [The FLS module shall call the callback function `Fee_JobErrorNotification` when the module has canceled an ongoing job:

- Read job aborted
- Write job aborted
- Erase job aborted
- Compare job aborted] (SRS_BSW_00387)

[SWS_Fls_00349] [The FLS module shall call the callback function `Fee_JobErrorNotification` when the module has finished a compare job and the memory blocks differ:

- Compare job finished and memory blocks differ] (SRS_BSW_00387)

9 Sequence diagrams

9.1 Initialization

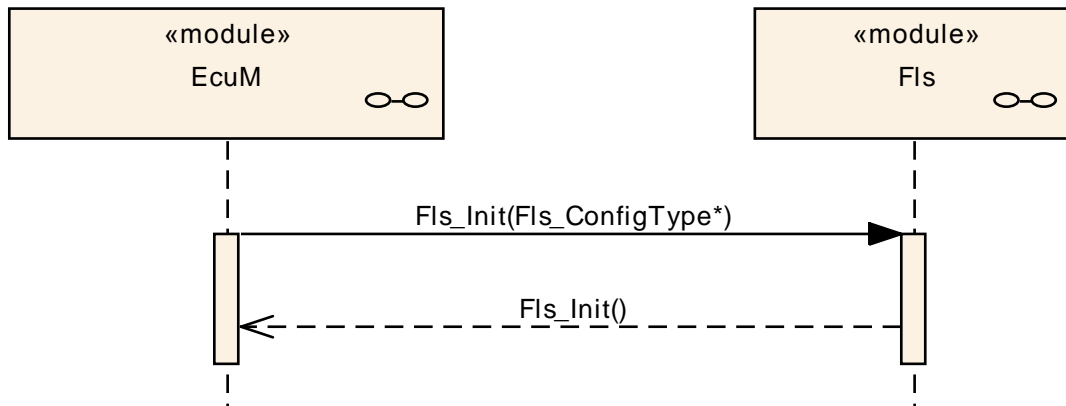

Figure 2: Flash driver initialization sequence

9.2 Synchronous functions

The following sequence diagram shows the function `Fls_GetJobResult` as an example for the synchronous functions of this module. The same sequence applies also to the functions `Fls_GetStatus` and `Fls_SetMode`.

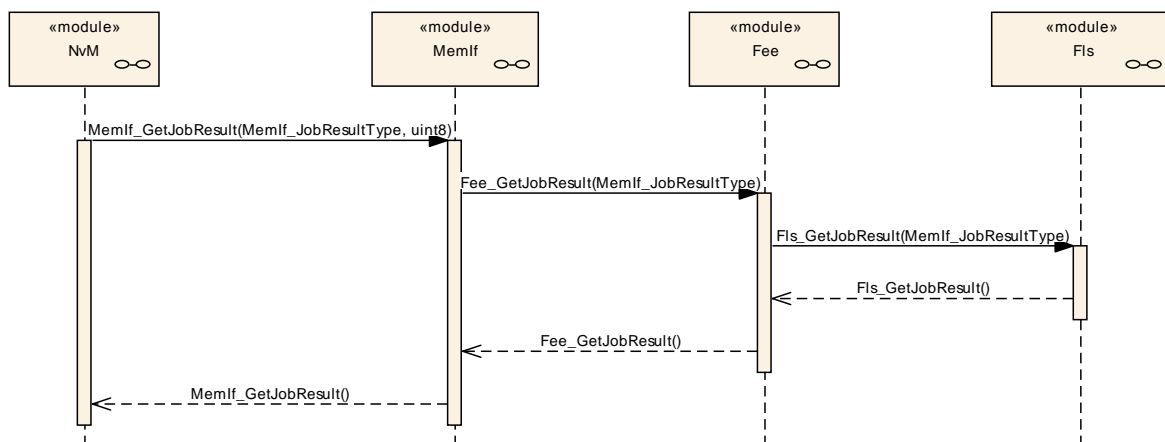

Figure 3: `Fls_GetJobResult`

9.3 Asynchronous functions

The following sequence diagram shows the flash write function (with the configuration option `FlsAcLoadOnJobStart` set) as an example for the asynchronous functions of this module. The same sequence applies to the erase, read and compare jobs, with the only difference that for the read and compare jobs no flash access code needs to be loaded to / unloaded from RAM.

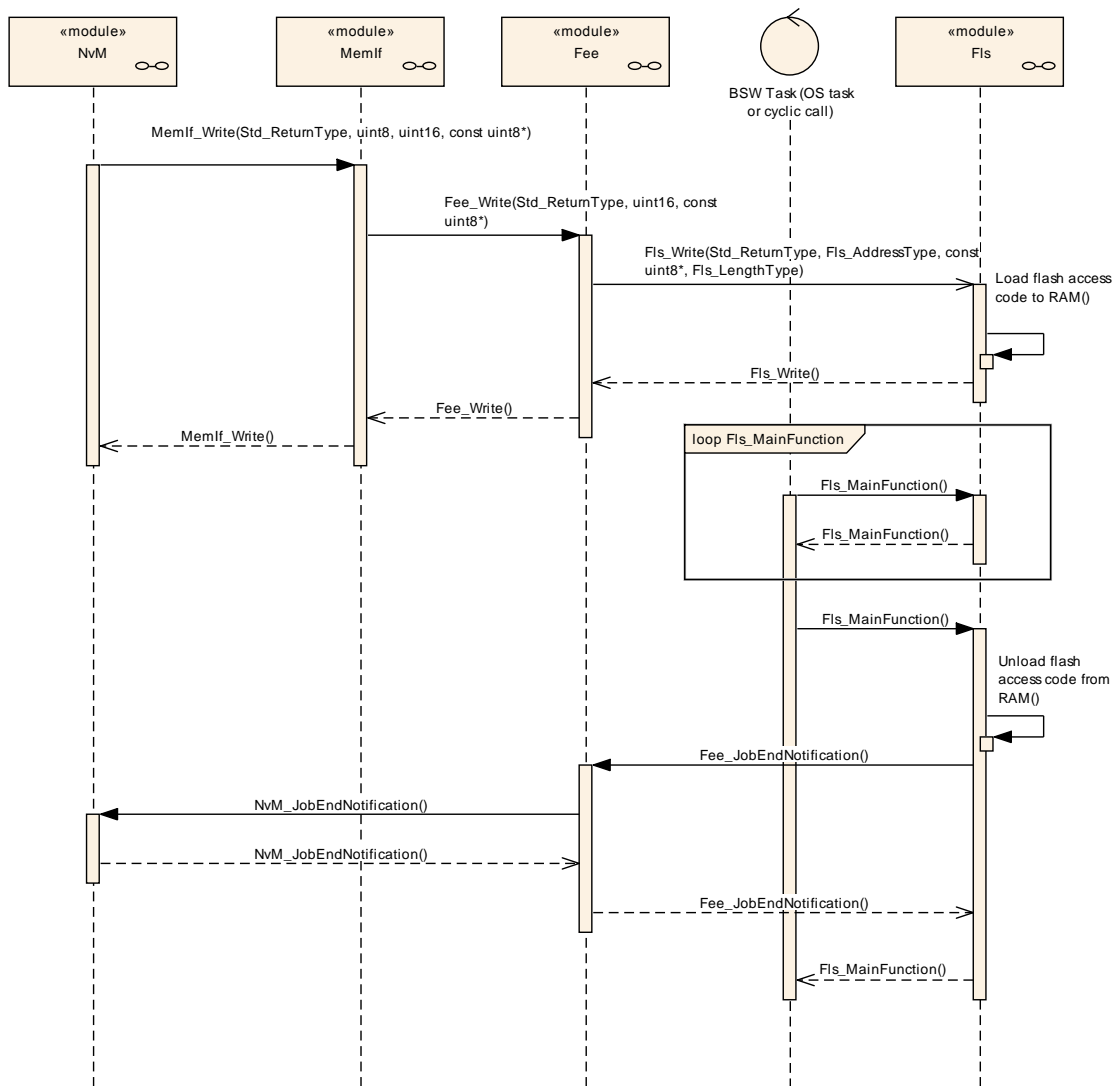

Figure 4: Flash write sequence, flash access code loaded on job start

9.4 Canceling a running job

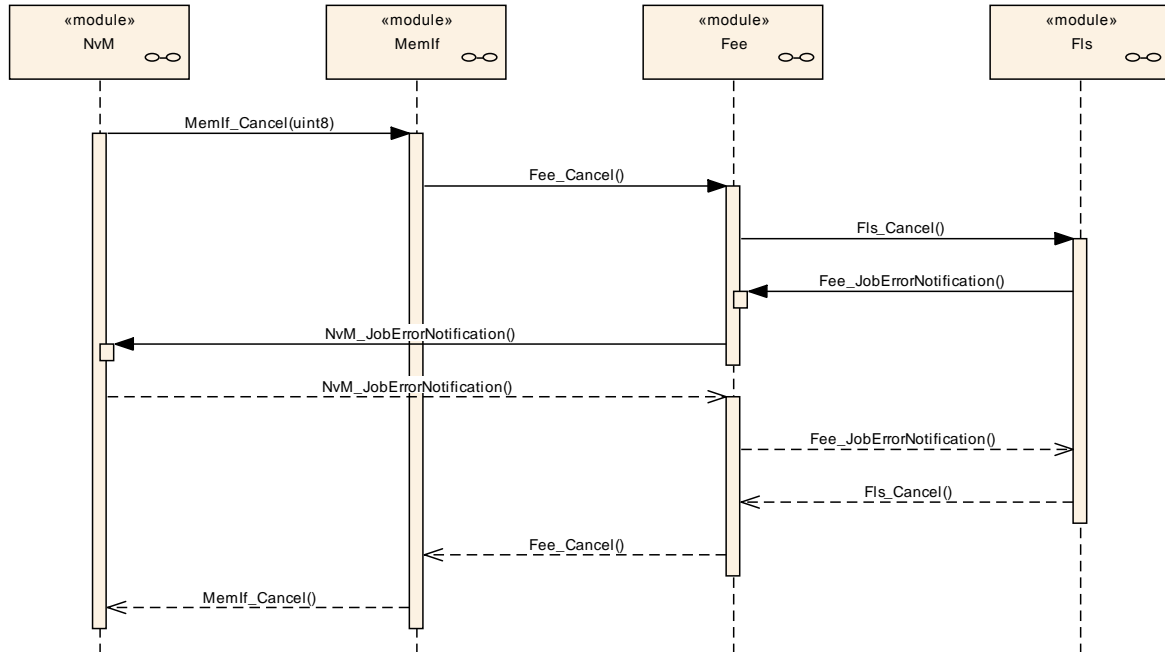

Figure 5: Canceling a running flash job

Note: The FLS module’s environment shall not call the function `Fls_Cancel` during a running `Fls_MainFunction` invocation.

This can be achieved by one of the following scheduling configurations:

- Possibility 1: The job functions of the NVRAM manager and the flash driver are synchronized (e.g. called sequentially within one task)
- Possibility 2: The task that calls the `Fls_MainFunction` function can not be preempted by another task.

10 Configuration specification

10.1 Containers and configuration parameters

The following chapters summarize all configuration parameters. The detailed meanings of the parameters describe Chapters 10.2 and Chapter 10.3.

10.1.1 Variants

[SWS_FIs_00203] [VARIANT-PRE-COMPILE

Only parameters with “Pre-compile time” configuration are allowed in this variant.]
(SWS_BSW_00345)

[SWS_FIs_00204] [VARIANT-POST-BUILD

Parameters with “Pre-compile time”, “Link time” and “Post-build time” are allowed in this variant.] (SWS_BSW_00404)

[SWS_FIs_00351] [Only one interface for initialization shall be implemented (in contradiction to SRS_BSW_00414) and it shall not depend on the modules configuration which interface the calling software module shall use.]
(SRS_BSW_00101)

10.1.2 Fls

SWS Item	ECUC_Fls_00001 :
Module Name	<i>Fls</i>
Module Description	Configuration of the Fls (internal or external flash driver) module. Its multiplicity describes the number of flash drivers present, so there will be one container for each flash driver in the ECUC template. When no flash driver is present then the multiplicity is 0.
Post-Build Variant Support	true

Included Containers		
Container Name	Multiplicity	Scope / Dependency
FlsConfigSet	1	Container for runtime configuration parameters of the flash driver. Implementation Type: Fls_ConfigType.
FlsGeneral	1	Container for general parameters of the flash driver. These parameters are always pre-compile.
FlsPublishedInformation	1	Additional published parameters not covered by CommonPublishedInformation container. Note that these parameters do not have any configuration class setting, since they are published information.

[SWS_Fls_00171|The table above specifies parameters that shall be configured during system generation. These parameters shall be located in the file `Fls_Cfg.h`. Further hardware or implementation specific parameters can be added if necessary.

| (SRS_BSW_00345, SRS_Fls_12132)

10.1.3 FlsGeneral

SWS Item	ECUC_Fls_00172 :
Container Name	FlsGeneral
Description	Container for general parameters of the flash driver. These parameters are always pre-compile.
Configuration Parameters	

SWS Item	ECUC_Fls_00284 :		
Name	FlsAcLoadOnJobStart		
Description	The flash driver shall load the flash access code to RAM whenever an erase or write job is started and unload (overwrite) it after that job has been finished or canceled. true: Flash access code loaded on job start / unloaded on job end or error. false: Flash access code not loaded to / unloaded from RAM at all.		
Multiplicity	1		
Type	EcucBooleanParamDef		
Default value	false		
Post-Build Variant Value	false		
Value Configuration Class	Pre-compile time	X	All Variants
	Link time	--	

	Post-build time	--	
Scope / Dependency	scope: local		

SWS Item	ECUC_Fls_00169 :		
Name	FlsBaseAddress		
Description	The flash memory start address (see also SWS_Fls_00208 and SWS_Fls_00209). This parameter defines the lower boundary for read / write / erase and compare jobs.		
Multiplicity	1		
Type	EcucIntegerParamDef		
Range	0 .. 4294967295		
Default value	--		
Post-Build Variant Value	false		
Value Configuration Class	Pre-compile time	X	All Variants
	Link time	--	
	Post-build time	--	
Scope / Dependency	scope: local		

SWS Item	ECUC_Fls_00319 :		
Name	FlsBlankCheckApi		
Description	Compile switch to enable/disable the Fls_BlankCheck function. true: API supported / function provided. false: API not supported / function not provided		
Multiplicity	1		
Type	EcucBooleanParamDef		
Default value	false		
Post-Build Variant Value	false		
Value Configuration Class	Pre-compile time	X	All Variants
	Link time	--	
	Post-build time	--	
Scope / Dependency	scope: local		

SWS Item	ECUC_Fls_00285 :		
Name	FlsCancelApi		
Description	Compile switch to enable and disable the Fls_Cancel function. true: API supported / function provided. false: API not supported / function not provided		
Multiplicity	1		
Type	EcucBooleanParamDef		
Default value	--		
Post-Build Variant Value	false		
Value Configuration Class	Pre-compile time	X	All Variants
	Link time	--	
	Post-build time	--	
Scope / Dependency	scope: local		

SWS Item	ECUC_Fls_00286 :		
Name	FlsCompareApi		
Description	Compile switch to enable and disable the Fls_Compare function. true: API supported / function provided. false: API not supported / function not provided		
Multiplicity	1		
Type	EcucBooleanParamDef		
Default value	--		
Post-Build Variant Value	false		

Value Configuration Class	Pre-compile time	X	All Variants
	Link time	--	
	Post-build time	--	
Scope / Dependency	scope: local		

SWS Item	ECUC_FIs_00287 :		
Name	FIsDevErrorDetect		
Description	Switches the Default Error Tracer (Det) detection and notification ON or OFF. <ul style="list-style-type: none"> true: enabled (ON). false: disabled (OFF). 		
Multiplicity	1		
Type	EcucBooleanParamDef		
Default value	true		
Post-Build Variant Value	false		
Value Configuration Class	Pre-compile time	X	All Variants
	Link time	--	
	Post-build time	--	
Scope / Dependency	scope: local		

SWS Item	ECUC_FIs_00288 :		
Name	FIsDriverIndex		
Description	Index of the driver, used by FEE.		
Multiplicity	1		
Type	EcucIntegerParamDef (Symbolic Name generated for this parameter)		
Range	0 .. 254		
Default value	--		
Post-Build Variant Value	false		
Value Configuration Class	Pre-compile time	X	All Variants
	Link time	--	
	Post-build time	--	
Scope / Dependency	scope: ECU		

SWS Item	ECUC_FIs_00289 :		
Name	FIsGetJobResultApi		
Description	Compile switch to enable and disable the FIs_GetJobResult function. true: API supported / function provided. false: API not supported / function not provided		
Multiplicity	1		
Type	EcucBooleanParamDef		
Default value	--		
Post-Build Variant Value	false		
Value Configuration Class	Pre-compile time	X	All Variants
	Link time	--	
	Post-build time	--	
Scope / Dependency	scope: local		

SWS Item	ECUC_FIs_00290 :		
Name	FIsGetStatusApi		
Description	Compile switch to enable and disable the FIs_GetStatus function. true: API supported / function provided. false: API not supported / function not provided		
Multiplicity	1		
Type	EcucBooleanParamDef		

Default value	--		
Post-Build Variant Value	false		
Value Configuration Class	Pre-compile time	X	All Variants
	Link time	--	
	Post-build time	--	
Scope / Dependency	scope: local		

SWS Item	ECUC_Fls_00291 :		
Name	FlsSetModeApi		
Description	Compile switch to enable and disable the Fls_SetMode function. true: API supported / function provided. false: API not supported / function not provided		
Multiplicity	1		
Type	EcucBooleanParamDef		
Default value	--		
Post-Build Variant Value	false		
Value Configuration Class	Pre-compile time	X	All Variants
	Link time	--	
	Post-build time	--	
Scope / Dependency	scope: local		

SWS Item	ECUC_Fls_00170 :		
Name	FlsTotalSize		
Description	The total amount of flash memory in bytes (see also SWS_Fls_00208 and SWS_Fls_00209). This parameter in conjunction with FLS_BASE_ADDRESS defines the upper boundary for read / write / erase and compare jobs.		
Multiplicity	1		
Type	EcucIntegerParamDef		
Range	0 .. 4294967295		
Default value	--		
Post-Build Variant Value	false		
Value Configuration Class	Pre-compile time	X	All Variants
	Link time	--	
	Post-build time	--	
Scope / Dependency	scope: local		

SWS Item	ECUC_Fls_00292 :		
Name	FlsUseInterrupts		
Description	Job processing triggered by hardware interrupt. true: Job processing triggered by interrupt (hardware controlled). false: Job processing not triggered by interrupt (software controlled) or the underlying hardware does not support interrupt mode for flash operations.		
Multiplicity	1		
Type	EcucBooleanParamDef		
Default value	false		
Post-Build Variant Value	false		
Value Configuration Class	Pre-compile time	X	All Variants
	Link time	--	
	Post-build time	--	
Scope / Dependency	scope: local dependency: Only available if supported by underlying flash hardware		

SWS Item	ECUC_Fls_00293 :		
Name	FlsVersionInfoApi		
Description	Pre-processor switch to enable / disable the API to read out the modules		

	version information. true: Version info API enabled. false: Version info API disabled.		
Multiplicity	1		
Type	EcucBooleanParamDef		
Default value	--		
Post-Build Variant Value	false		
Value Configuration Class	Pre-compile time	X	All Variants
	Link time	--	
	Post-build time	--	
Scope / Dependency	scope: local		

No Included Containers

10.1.4 FlsConfigSet

SWS Item	ECUC_Fls_00174 :		
Container Name	FlsConfigSet		
Description	Container for runtime configuration parameters of the flash driver. Implementation Type: Fls_ConfigType.		
Configuration Parameters			

SWS Item	ECUC_Fls_00270 :		
Name	FlsAcErase		
Description	Address offset in RAM to which the erase flash access code shall be loaded. Used as function pointer to access the erase flash access code.		
Multiplicity	1		
Type	EcucIntegerParamDef		
Range	0 .. 4294967295		
Default value	--		
Post-Build Variant Value	true		
Value Configuration Class	Pre-compile time	X	VARIANT-PRE-COMPILE
	Link time	--	
	Post-build time	X	VARIANT-POST-BUILD
Scope / Dependency	scope: local		

SWS Item	ECUC_Fls_00305 :		
Name	FlsAcWrite		
Description	Address offset in RAM to which the write flash access code shall be loaded. Used as function pointer to access the write flash access code.		
Multiplicity	1		
Type	EcucIntegerParamDef		
Range	0 .. 4294967295		
Default value	--		
Post-Build Variant Value	true		
Value Configuration Class	Pre-compile time	X	VARIANT-PRE-COMPILE
	Link time	--	
	Post-build time	X	VARIANT-POST-BUILD
Scope / Dependency	scope: local		

SWS Item	ECUC_Fls_00306 :		
Name	FlsCallCycle		

Description	Cycle time of calls of the flash driver's main function (in seconds).		
Multiplicity	1		
Type	EcucFloatParamDef		
Range	0 .. 1		
Default value	--		
Post-Build Variant Value	true		
Value Configuration Class	Pre-compile time	X	VARIANT-PRE-COMPILE
	Link time	--	
	Post-build time	X	VARIANT-POST-BUILD
Scope / Dependency	scope: local dependency: Only relevant if deadline monitoring for internal functionality has to be done in software (e.g. erase / write timings)		

SWS Item	ECUC_Fls_00318 :		
Name	FlsDefaultMode		
Description	This parameter is the default FLS device mode after initialization. Implementation Type: MemIf_ModeType.		
Multiplicity	1		
Type	EcucEnumerationParamDef		
Range	MEMIF_MODE_FAST		The driver is working in fast mode (fast read access / SPI burst access).
	MEMIF_MODE_SLOW		The driver is working in slow mode.
Default value	MEMIF_MODE_SLOW		
Post-Build Variant Value	true		
Value Configuration Class	Pre-compile time	X	VARIANT-PRE-COMPILE
	Link time	--	
	Post-build time	X	VARIANT-POST-BUILD
Scope Dependency	scope: local		

SWS Item	ECUC_Fls_00307 :		
Name	FlsJobEndNotification		
Description	Mapped to the job end notification routine provided by some upper layer module, typically the Fee module.		
Multiplicity	0..1		
Type	EcucFunctionNameDef		
Default value	--		
maxLength	--		
minLength	--		
regularExpression	--		
Post-Build Variant Multiplicity	true		
Post-Build Variant Value	true		
Multiplicity Configuration Class	Pre-compile time	X	VARIANT-PRE-COMPILE
	Link time	--	
	Post-build time	X	VARIANT-POST-BUILD
Value Configuration Class	Pre-compile time	X	VARIANT-PRE-COMPILE
	Link time	--	
	Post-build time	X	VARIANT-POST-BUILD
Scope / Dependency	scope: local		

SWS Item	ECUC_Fls_00274 :		
Name	FlsJobErrorNotification		
Description	Mapped to the job error notification routine provided by some upper layer module, typically the Fee module.		

Multiplicity	0..1		
Type	EcucFunctionNameDef		
Default value	--		
maxLength	--		
minLength	--		
regularExpression	--		
Post-Build Multiplicity	Variant	true	
Post-Build Variant Value	true		
Multiplicity Configuration Class	Pre-compile time	X	VARIANT-PRE-COMPILE
	Link time	--	
	Post-build time	X	VARIANT-POST-BUILD
Value Configuration Class	Pre-compile time	X	VARIANT-PRE-COMPILE
	Link time	--	
	Post-build time	X	VARIANT-POST-BUILD
Scope / Dependency	scope: local		

SWS Item	ECUC_Fls_00275 :		
Name	FlsMaxReadFastMode		
Description	The maximum number of bytes to read or compare in one cycle of the flash driver's job processing function in fast mode.		
Multiplicity	1		
Type	EcucIntegerParamDef		
Range	0 .. 4294967295		
Default value	--		
Post-Build Variant Value	true		
Value Configuration Class	Pre-compile time	X	VARIANT-PRE-COMPILE
	Link time	--	
	Post-build time	X	VARIANT-POST-BUILD
Scope / Dependency	scope: local dependency: The minimum number might depend on the underlying flash device or communication driver, e.g. if the access to an external flash device is done via SPI and the minimum transfer size on SPI is four bytes.		

SWS Item	ECUC_Fls_00276 :		
Name	FlsMaxReadNormalMode		
Description	The maximum number of bytes to read or compare in one cycle of the flash driver's job processing function in normal mode.		
Multiplicity	1		
Type	EcucIntegerParamDef		
Range	0 .. 4294967295		
Default value	--		
Post-Build Variant Value	true		
Value Configuration Class	Pre-compile time	X	VARIANT-PRE-COMPILE
	Link time	--	
	Post-build time	X	VARIANT-POST-BUILD
Scope / Dependency	scope: local dependency: The minimum number might depend on the underlying flash device or communication driver, e.g. if the access to an external flash device is done via SPI and the minimum transfer size on SPI is four bytes.		

SWS Item	ECUC_Fls_00277 :		
Name	FlsMaxWriteFastMode		
Description	The maximum number of bytes to write in one cycle of the flash driver's job processing function in fast mode.		
Multiplicity	1		

Type	EcucIntegerParamDef		
Range	0 .. 4294967295		
Default value	--		
Post-Build Variant Value	true		
Value Configuration Class	Pre-compile time	X	VARIANT-PRE-COMPILE
	Link time	--	
	Post-build time	X	VARIANT-POST-BUILD
Scope / Dependency	scope: local dependency: FLS182: This value has to correspond to the settings in FLS_PAGE_LIST. The minimum number is defined by the size of one flash page and therefore depends on the underlying flash device.		

SWS Item	ECUC_Fls_00278 :		
Name	FlsMaxWriteNormalMode		
Description	The maximum number of bytes to write in one cycle of the flash driver's job processing function in normal mode.		
Multiplicity	1		
Type	EcucIntegerParamDef		
Range	0 .. 4294967295		
Default value	--		
Post-Build Variant Value	true		
Value Configuration Class	Pre-compile time	X	VARIANT-PRE-COMPILE
	Link time	--	
	Post-build time	X	VARIANT-POST-BUILD
Scope / Dependency	scope: local dependency: This value has to correspond to the settings in FLS_PAGE_LIST. The minimum number is defined by the size of one flash page and therefore depends on the underlying flash device.		

SWS Item	ECUC_Fls_00279 :		
Name	FlsProtection		
Description	Erase/write protection settings. Only relevant if supported by hardware.		
Multiplicity	1		
Type	EcucIntegerParamDef		
Range	0 .. 4294967295		
Default value	--		
Post-Build Variant Value	true		
Value Configuration Class	Pre-compile time	X	VARIANT-PRE-COMPILE
	Link time	--	
	Post-build time	X	VARIANT-POST-BUILD
Scope / Dependency	scope: local dependency: Only relevant if supported by hardware.		

Included Containers		
Container Name	Multiplicity	Scope / Dependency
FlsDemEventParameterRefs	0..1	Container for the references to DemEventParameter elements which shall be invoked using the Dem_ReportErrorStatus API in case the corresponding error occurs. The EventId is taken from the referenced DemEventParameter's DemEventId value. The standardized errors are provided in the container and can be extended by vendor specific error references. Tags: atp.Status=obsolete atp.StatusComment=This container is set to obsolete and will be removed in release 4.3. atp.StatusRevisionBegin=4.2.2
FlsExternalDriver	0..1	This container is present for external Flash drivers only.

		Internal Flash drivers do not use the parameter listed in this container, hence its multiplicity is 0 for internal drivers.
FlsSectorList	1	List of flashable sectors and pages.

[SWS_Fls_00352] [The table above specifies the parameters that shall be located in an external data structure of type `Fls_ConfigType`.] (SRS_BSW_00438, SRS_BSW_00388)

[SWS_Fls_00353] [The organization and location of the data structure `Fls_ConfigType` shall be up to the implementer.] (SRS_BSW_00438)

[SWS_Fls_00354] [The type declaration for `Fls_ConfigType` shall be located in the file `Fls.h`.] (SRS_BSW_00438)

[SWS_Fls_00355] [Hardware or implementation specific parameters can be added to `Fls_ConfigType` if necessary.] (SRS_BSW_00438)

10.1.5 FlsDemEventParameterRefs

SWS Item	ECUC_Fls_00310 : (Obsolete)
Container Name	FlsDemEventParameterRefs
Description	<p>Container for the references to DemEventParameter elements which shall be invoked using the Dem_ReportErrorStatus API in case the corresponding error occurs. The EventId is taken from the referenced DemEventParameter's DemEventId value. The standardized errors are provided in the container and can be extended by vendor specific error references.</p> <p>Tags: atp.Status=obsolete atp.StatusComment=This container is set to obsolete and will be removed in release 4.3. atp.StatusRevisionBegin=4.2.2</p>
Configuration Parameters	

SWS Item	ECUC_Fls_00314 : (Obsolete)		
Name	FLS_E_COMPARE_FAILED		
Description	<p>Reference to the DemEventParameter which shall be issued when the error "Flash compare failed (HW)" has occurred.</p> <p>Tags: atp.Status=obsolete atp.StatusComment=This reference is set to obsolete and will be removed in release 4.3. atp.StatusRevisionBegin=4.2.2</p>		
Multiplicity	0..1		
Type	Symbolic name reference to [DemEventParameter]		
Post-Build Multiplicity	Variant	true	
Post-Build Variant Value	true		
Multiplicity Configuration Class	Pre-compile time	X	VARIANT-PRE-COMPILE
	Link time	--	
	Post-build time	X	VARIANT-POST-BUILD
Value Configuration Class	Pre-compile time	X	VARIANT-PRE-COMPILE

	Link time	--	
	Post-build time	X	VARIANT-POST-BUILD
Scope / Dependency	scope: local		

SWS Item	ECUC_Fls_00311 : (Obsolete)		
Name	FLS_E_ERASE_FAILED		
Description	Reference to the DemEventParameter which shall be issued when the error "Flash erase failed (HW)" has occurred. Tags: atp.Status=obsolete atp.StatusComment=This reference is set to obsolete and will be removed in release 4.3. atp.StatusRevisionBegin=4.2.2		
Multiplicity	0..1		
Type	Symbolic name reference to [DemEventParameter]		
Post-Build Multiplicity	Variant	true	
Post-Build Variant Value	true		
Multiplicity Configuration Class	Pre-compile time	X	VARIANT-PRE-COMPILE
	Link time	--	
	Post-build time	X	VARIANT-POST-BUILD
Value Configuration Class	Pre-compile time	X	VARIANT-PRE-COMPILE
	Link time	--	
	Post-build time	X	VARIANT-POST-BUILD
Scope / Dependency	scope: local		

SWS Item	ECUC_Fls_00313 : (Obsolete)		
Name	FLS_E_READ_FAILED		
Description	Reference to the DemEventParameter which shall be issued when the error "Flash read failed (HW)" has occurred. Tags: atp.Status=obsolete atp.StatusComment=This reference is set to obsolete and will be removed in release 4.3. atp.StatusRevisionBegin=4.2.2		
Multiplicity	0..1		
Type	Symbolic name reference to [DemEventParameter]		
Post-Build Multiplicity	Variant	true	
Post-Build Variant Value	true		
Multiplicity Configuration Class	Pre-compile time	X	VARIANT-PRE-COMPILE
	Link time	--	
	Post-build time	X	VARIANT-POST-BUILD
Value Configuration Class	Pre-compile time	X	VARIANT-PRE-COMPILE
	Link time	--	
	Post-build time	X	VARIANT-POST-BUILD
Scope / Dependency	scope: local		

SWS Item	ECUC_Fls_00315 : (Obsolete)		
Name	FLS_E_UNEXPECTED_FLASH_ID		
Description	Reference to the DemEventParameter which shall be issued when the error "Expected hardware ID not matched" has occurred. Tags: atp.Status=obsolete atp.StatusComment=This reference is set to obsolete and will be removed in release 4.3. atp.StatusRevisionBegin=4.2.2		

Multiplicity	0..1		
Type	Symbolic name reference to [DemEventParameter]		
Post-Build Multiplicity Variant	true		
Post-Build Variant Value	true		
Multiplicity Configuration Class	Pre-compile time	X	VARIANT-PRE-COMPILE
	Link time	--	
	Post-build time	X	VARIANT-POST-BUILD
Value Configuration Class	Pre-compile time	X	VARIANT-PRE-COMPILE
	Link time	--	
	Post-build time	X	VARIANT-POST-BUILD
Scope / Dependency	scope: local		

SWS Item	ECUC_Fls_00312 : (Obsolete)		
Name	FLS_E_WRITE_FAILED		
Description	Reference to the DemEventParameter which shall be issued when the error "Flash write failed (HW)" has occurred. Tags: atp.Status=obsolete atp.StatusComment=This reference is set to obsolete and will be removed in release 4.3. atp.StatusRevisionBegin=4.2.2		
Multiplicity	0..1		
Type	Symbolic name reference to [DemEventParameter]		
Post-Build Multiplicity Variant	true		
Post-Build Variant Value	true		
Multiplicity Configuration Class	Pre-compile time	X	VARIANT-PRE-COMPILE
	Link time	--	
	Post-build time	X	VARIANT-POST-BUILD
Value Configuration Class	Pre-compile time	X	VARIANT-PRE-COMPILE
	Link time	--	
	Post-build time	X	VARIANT-POST-BUILD
Scope / Dependency	scope: local		

No Included Containers

10.1.6 FlsExternalDriver

SWS Item	ECUC_Fls_00316 :
Container Name	FlsExternalDriver
Description	This container is present for external Flash drivers only. Internal Flash drivers do not use the parameter listed in this container, hence its multiplicity is 0 for internal drivers.
Configuration Parameters	

SWS Item	ECUC_Fls_00317 :
Name	FlsSpiReference
Description	Reference to SPI sequence (required for external Flash drivers).
Multiplicity	1..*
Type	Symbolic name reference to [SpiSequence]
Post-Build Multiplicity Variant	false

Post-Build Variant Value	false		
Multiplicity Configuration Class	Pre-compile time	X	All Variants
	Link time	--	
	Post-build time	--	
Value Configuration Class	Pre-compile time	X	All Variants
	Link time	--	
	Post-build time	--	
Scope / Dependency	scope: local		

No Included Containers

10.1.7 FlsSectorList

SWS Item	ECUC_Fls_00201 :
Container Name	FlsSectorList
Description	List of flashable sectors and pages.
Configuration Parameters	

Included Containers		
Container Name	Multiplicity	Scope / Dependency
FlsSector	1..*	Configuration description of a flashable sector

10.1.8 FlsSector

SWS Item	ECUC_Fls_00202 :
Container Name	FlsSector
Description	Configuration description of a flashable sector
Configuration Parameters	

SWS Item	ECUC_Fls_00280 :		
Name	FlsNumberOfSectors		
Description	Number of continuous sectors with identical values for FlsSectorSize and FlsPageSize. The parameter FlsSectorStartAddress denotes the start address of the first sector.		
Multiplicity	1		
Type	EcuIntegerParamDef		
Range	0 .. 65535		
Default value	--		
Post-Build Variant Value	false		
Value Configuration Class	Pre-compile time	X	All Variants
	Link time	--	
	Post-build time	--	
Scope / Dependency	scope: local		

SWS Item	ECUC_Fls_00281 :		
Name	FlsPageSize		
Description	Size of one page of this sector. Implementation Type: Fls_LengthType.		
Multiplicity	1		
Type	EcuIntegerParamDef		
Range	0 .. 4294967295		
Default value	--		

Post-Build Variant Value	false		
Value Configuration Class	Pre-compile time	X	All Variants
	Link time	--	
	Post-build time	--	
Scope / Dependency	scope: local dependency: The sector size has to be an integer multiple of the page size.		

SWS Item	ECUC_Fls_00282 :		
Name	FlsSectorSize		
Description	Size of this sector. Implementation Type: Fls_LengthType.		
Multiplicity	1		
Type	EcucIntegerParamDef		
Range	0 .. 4294967295		
Default value	--		
Post-Build Variant Value	false		
Value Configuration Class	Pre-compile time	X	All Variants
	Link time	--	
	Post-build time	--	
Scope / Dependency	scope: local dependency: The sector size has to be an integer multiple of the page size.		

SWS Item	ECUC_Fls_00283 :		
Name	FlsSectorStartaddress		
Description	Start address of this sector. Implementation Type: Fls_AddressType.		
Multiplicity	1		
Type	EcucIntegerParamDef		
Range	0 .. 4294967295		
Default value	--		
Post-Build Variant Value	false		
Value Configuration Class	Pre-compile time	X	All Variants
	Link time	--	
	Post-build time	--	
Scope / Dependency	scope: local		

No Included Containers

10.2 Published Information

10.2.1 FlsPublishedInformation

SWS Item	ECUC_Fls_00178 :		
Container Name	FlsPublishedInformation		
Description	Additional published parameters not covered by CommonPublishedInformation container. Note that these parameters do not have any configuration class setting, since they are published information.		
Configuration Parameters			

SWS Item	ECUC_FIs_00294 :		
Name	FIsAcLocationErase		
Description	Position in RAM, to which the erase flash access code has to be loaded. Only relevant if the erase flash access code is not position independent. If this information is not provided it is assumed that the erase flash access code is position independent and that therefore the RAM position can be freely configured.		
Multiplicity	1		
Type	EcucIntegerParamDef		
Range	0 .. 4294967295		
Default value	--		
Post-Build Variant Value	false		
Value Configuration Class	Published Information	X	All Variants
Scope / Dependency	scope: local		

SWS Item	ECUC_FIs_00295 :		
Name	FIsAcLocationWrite		
Description	Position in RAM, to which the write flash access code has to be loaded. Only relevant if the write flash access code is not position independent. If this information is not provided it is assumed that the write flash access code is position independent and that therefore the RAM position can be freely configured.		
Multiplicity	1		
Type	EcucIntegerParamDef		
Range	0 .. 4294967295		
Default value	--		
Post-Build Variant Value	false		
Value Configuration Class	Published Information	X	All Variants
Scope / Dependency	scope: local		

SWS Item	ECUC_FIs_00296 :		
Name	FIsAcSizeErase		
Description	Number of bytes in RAM needed for the erase flash access code.		
Multiplicity	1		
Type	EcucIntegerParamDef		
Range	0 .. 4294967295		
Default value	--		
Post-Build Variant Value	false		
Value Configuration Class	Published Information	X	All Variants
Scope / Dependency	scope: local		

SWS Item	ECUC_FIs_00297 :		
Name	FIsAcSizeWrite		
Description	Number of bytes in RAM needed for the write flash access code.		
Multiplicity	1		
Type	EcucIntegerParamDef		
Range	0 .. 4294967295		
Default value	--		
Post-Build Variant Value	false		
Value Configuration Class	Published Information	X	All Variants
Scope / Dependency	scope: local		

SWS Item	ECUC_FIs_00298 :		
Name	FIsEraseTime		
Description	Maximum time to erase one complete flash sector.		

Multiplicity	1		
Type	EcucFloatParamDef		
Range	0 .. INF		
Default value	--		
Post-Build Variant Value	false		
Value Configuration Class	Published Information	X	All Variants
Scope / Dependency	scope: local		

SWS Item	ECUC_FIs_00299 :		
Name	FIsErasedValue		
Description	The contents of an erased flash memory cell.		
Multiplicity	1		
Type	EcucIntegerParamDef		
Range	0 .. 4294967295		
Default value	--		
Post-Build Variant Value	false		
Value Configuration Class	Published Information	X	All Variants
Scope / Dependency	scope: local		

SWS Item	ECUC_FIs_00300 :		
Name	FIsExpectedHwId		
Description	Unique identifier of the hardware device that is expected by this driver (the device for which this driver has been implemented). Only relevant for external flash drivers.		
Multiplicity	1		
Type	EcucStringParamDef		
Default value	--		
maxLength	--		
minLength	--		
regularExpression	--		
Post-Build Variant Value	false		
Value Configuration Class	Published Information	X	All Variants
Scope / Dependency	scope: local		

SWS Item	ECUC_FIs_00198 :		
Name	FIsSpecifiedEraseCycles		
Description	Number of erase cycles specified for the flash device (usually given in the device data sheet). If the number of specified erase cycles depends on the operating environment (temperature, voltage, ...) during reprogramming of the flash device, the minimum number for which a data retention of at least 15 years over the temperature range from -40°C .. +125°C can be guaranteed shall be given. Note: If there are different numbers of specified erase cycles for different flash sectors of the device this parameter has to be extended to a parameter list (similar to the sector list above).		
Multiplicity	1		
Type	EcucIntegerParamDef		
Range	0 .. 4294967295		
Default value	--		
Post-Build Variant Value	false		
Value Configuration Class	Published Information	X	All Variants
Scope / Dependency	scope: local		

SWS Item	ECUC_FIs_00301 :		
Name	FIsWriteTime		

Description	Maximum time to program one complete flash page.		
Multiplicity	1		
Type	EcucFloatParamDef		
Range	0 .. INF		
Default value	--		
Post-Build Variant Value	false		
Value Configuration Class	Published Information	X	All Variants
Scope / Dependency	scope: local		

No Included Containers

11 Not applicable requirements

[SWS_FIs_00366] [These requirements are not applicable to this specification.]
(SRS_BSW_00344, SRS_BSW_00170, SRS_BSW_00387, SRS_BSW_00398, SRS_BSW_00375,
SRS_BSW_00416, SRS_BSW_00168, SRS_BSW_00423, SRS_BSW_00424, SRS_BSW_00426,
SRS_BSW_00427, SRS_BSW_00428, SRS_BSW_00429, SRS_BSW_00433, SRS_BSW_00336,
SRS_BSW_00339, SRS_BSW_00422, SRS_BSW_00417, SRS_BSW_00161, SRS_BSW_00162,
SRS_BSW_00005, SRS_BSW_00415, SRS_BSW_00326, SRS_BSW_00342, SRS_BSW_00160,
SRS_BSW_00007, SRS_BSW_00300, SRS_BSW_00347, SRS_BSW_00307, SRS_BSW_00314,
SRS_BSW_00370, SRS_BSW_00348, SRS_BSW_00353, SRS_BSW_00361, SRS_BSW_00302,
SRS_BSW_00328, SRS_BSW_00312, SRS_BSW_00006, SRS_BSW_00304, SRS_BSW_00355,
SRS_BSW_00378, SRS_BSW_00306, SRS_BSW_00308, SRS_BSW_00309, SRS_BSW_00371,
SRS_BSW_00359, SRS_BSW_00360, SRS_BSW_00330, SRS_BSW_00009, SRS_BSW_00401,
SRS_BSW_00172, SRS_BSW_00010, SRS_BSW_00333, SRS_BSW_00321, SRS_BSW_00341,
SRS_BSW_00334, SRS_SPAL_12267, SRS_SPAL_12163, SRS_SPAL_12462, SRS_SPAL_12463,
SRS_SPAL_12069, SRS_SPAL_12063, SRS_SPAL_12064, SRS_SPAL_12067, SRS_SPAL_12078,
SRS_SPAL_12078, SRS_FIs_12083, SRS_FIs_12149)