

Document Title	Specification of CRC Routines
Document Owner	AUTOSAR
Document Responsibility	AUTOSAR
Document Identification No	016
Document Classification	Standard

Document Status	Final
Part of AUTOSAR Release	4.2.2

Document Change History		
Release	Changed by	Change Description
4.2.2	AUTOSAR Release Management	<ul style="list-style-type: none"> Corrected the magic check for the CRC32 and CRC32P4
4.2.1	AUTOSAR Release Management	<ul style="list-style-type: none"> Introduction of a new CRC-32 with the polynomial 0xF4ACFB13 Editorial changes
4.1.3	AUTOSAR Release Management	<ul style="list-style-type: none"> CRC32 IEEE 802.3 check values corrected Editorial changes
4.1.2	AUTOSAR Release Management	<ul style="list-style-type: none"> Editorial changes Removed chapter(s) on change documentation
4.1.1	AUTOSAR Administration	<ul style="list-style-type: none"> New examples on how to use CRC routines and clarifications concerning CCITT standard Removal of debugging concept
4.0.3	AUTOSAR Administration	<ul style="list-style-type: none"> The GetVersionInfo API is always available
3.1.5	AUTOSAR Administration	<ul style="list-style-type: none"> New parameter added to APIs in order to chain CRC computations. CRC check values corrected and checked values better explained. CRC magic check added.
3.1.4	AUTOSAR Administration	<ul style="list-style-type: none"> Introduction of a new CRC-8 with the polynomial 2Fh CRC-8 is now compliant to SAE J1850 Legal disclaimer revised
3.1.1	AUTOSAR Administration	<ul style="list-style-type: none"> Separated CRC requirements from Memory Services Requirements CRC8 management added
3.0.2	AUTOSAR Administration	<ul style="list-style-type: none"> Separated CRC requirements from Memory Services Requirements CRC8 management added
3.0.1	AUTOSAR Administration	<ul style="list-style-type: none"> Document meta information extended Small layout adaptations made

Document Change History		
Release	Changed by	Change Description
2.1.15	AUTOSAR Administration	<ul style="list-style-type: none"> • “Advice for users” revised • “Revision Information” added
2.1.1	AUTOSAR Administration	<ul style="list-style-type: none"> • Crc_CalculateCRC16 and Crc_CalculateCRC32 APIs, Crc_DataPtr parameter : void pointer changed to uint8 pointer • Legal disclaimer revised
2.0	AUTOSAR Administration	<ul style="list-style-type: none"> • Document structure adapted to common Release 2.0 SWS Template. • UML model introduction • Requirements traceability update • Reentrancy at calculating CRC with hardware support
1.0	AUTOSAR Administration	<ul style="list-style-type: none"> • Initial Release

Disclaimer

This specification and the material contained in it, as released by AUTOSAR, is for the purpose of information only. AUTOSAR and the companies that have contributed to it shall not be liable for any use of the specification.

The material contained in this specification is protected by copyright and other types of Intellectual Property Rights. The commercial exploitation of the material contained in this specification requires a license to such Intellectual Property Rights.

This specification may be utilized or reproduced without any modification, in any form or by any means, for informational purposes only. For any other purpose, no part of the specification may be utilized or reproduced, in any form or by any means, without permission in writing from the publisher.

The AUTOSAR specifications have been developed for automotive applications only. They have neither been developed, nor tested for non-automotive applications.

The word AUTOSAR and the AUTOSAR logo are registered trademarks.

Advice for users

AUTOSAR specifications may contain exemplary items (exemplary reference models, "use cases", and/or references to exemplary technical solutions, devices, processes or software).

Any such exemplary items are contained in the specifications for illustration purposes only, and they themselves are not part of the AUTOSAR Standard. Neither their presence in such specifications, nor any later documentation of AUTOSAR conformance of products actually implementing such exemplary items, imply that intellectual property rights covering such exemplary items are licensed under the same rules as applicable to the AUTOSAR Standard.

Table of Contents

1	Introduction and functional overview	6
2	Acronyms and abbreviations	7
3	Related documentation.....	8
3.1	Input documents	8
3.2	Related standards and norms	8
4	Constraints and assumptions	10
4.1	Limitations	10
4.2	Applicability to car domains	10
5	Dependencies to other modules.....	11
5.1	File structure.....	11
6	Requirements traceability	12
7	Functional specification	18
7.1	Basic Concepts of CRC Codes	18
7.1.1	Mathematical Description	18
7.1.2	Euclidian Algorithm for Binary Polynomials and Bit-Sequences	20
7.1.3	CRC calculation, Variations and Parameter	21
7.2	Standard parameters.....	21
7.2.1	8-bit CRC calculation	23
7.2.1.1	8-bit SAE J1850 CRC Calculation	23
7.2.1.2	8-bit 0x2F polynomial CRC Calculation	24
7.2.2	16-bit CRC calculation	24
7.2.2.1	16-bit CCITT-FALSE CRC16.....	24
7.2.3	32-bit CRC calculation	25
7.2.3.1	32-bit Ethernet CRC Calculation	25
7.2.3.2	32-bit 0xF4ACFB13 polynomial CRC calculation	26
7.3	General behavior	28
7.4	Error classification	28
7.5	Error detection	28
7.6	Error notification	28
7.7	Version check.....	28
7.8	Debugging concept.....	28
8	API specification	29
8.1	Imported types.....	29
8.2	Type definitions	29
8.3	Function definitions.....	29
8.3.1	8-bit CRC Calculation	32
8.3.1.1	8-bit SAE J1850 CRC Calculation	32
8.3.1.2	8-bit 0x2F polynomial CRC Calculation	33
8.3.2	16-bit CRC Calculation	34
8.3.2.1	16-bit CCITT-FALSE CRC16.....	34
8.3.3	32-bit CRC Calculation	35
8.3.3.1	32-bit Ethernet CRC Calculation	35

8.3.3.2	32-bit 0xF4ACFB13 polynomial CRC calculation	36
8.3.4	Crc_GetVersionInfo	37
8.4	Call-back notifications.....	37
8.5	Scheduled functions	37
8.6	Expected Interfaces.....	37
8.6.1	Mandatory Interfaces	38
8.6.2	Optional Interfaces.....	38
8.6.3	Configurable interfaces.....	38
9	Sequence diagrams	39
9.1	Crc_CalculateCRC8().....	39
9.2	Crc_CalculateCRC8H2F()	39
9.3	Crc_CalculateCRC16().....	39
9.4	Crc_CalculateCRC32().....	40
9.5	Crc_CalculateCRC32P4()	41
10	Configuration specification.....	42
10.1	How to read this chapter	42
10.1.1	Configuration and configuration parameters.....	42
10.1.2	Variants	42
10.1.3	Containers	42
10.2	Containers and configuration parameters	43
10.2.1	Variants	44
10.2.2	Crc.....	44
10.2.3	CrcGeneral	44
10.3	Published Information.....	47
11	Not applicable requirements	48

1 Introduction and functional overview

This specification specifies the functionality, API and the configuration of the AUTOSAR Basic Software module CRC.

The CRC library contains the following routines for CRC calculation:

- CRC8 SAEJ1850
- CRC8H2F: CRC8 0x2F polynomial
- CRC16
- CRC32
- CRC32P4: CRC32 0x1F4ACFB13 polynomial

For all routines (CRC8, CRC8H2F, CRC16, CRC32 and CRC32P4), the following calculation methods are possible:

- Table based calculation:
Fast execution, but larger code size (ROM table)
- Runtime calculation:
Slower execution, but small code size (no ROM table)
- Hardware supported CRC calculation (device specific):
Fast execution, less CPU time

All routines are re-entrant and can be used by multiple applications at the same time. Hardware supported CRC calculation may be supported by some devices in the future.

2 Acronyms and abbreviations

Acronyms and abbreviations, which have a local scope and therefore are not contained in the AUTOSAR glossary, must appear in a local glossary.

<i>Abbreviation / Acronym:</i>	<i>Description:</i>
CRC	Cyclic Redundancy Check
ALU	Arithmetic Logic Unit

3 Related documentation

3.1 Input documents

- [1] List of Basic Software Modules,
AUTOSAR_TR_BSWModuleList.pdf
- [2] Layered Software Architecture,
AUTOSAR_EXP_LayeredSoftwareArchitecture.pdf
- [3] General Requirements on Basic Software Modules,
AUTOSAR_SRS_BSWGeneral.pdf
- [4] Requirements on Libraries,
AUTOSAR_SRS_Libraries.pdf
- [5] Specification of ECU Configuration,
AUTOSAR_TPS_ECUConfiguration.pdf
- [6] A Painless Guide To CRC Error Detection Algorithms, Ross N. Williams
- [7] Basic Software Module Description Template,
AUTOSAR_TPS_BSWModuleDescriptionTemplate.pdf
- [8] Specification of Platform Types,
AUTOSAR_SWS_PlatformTypes.pdf
- [9] Specification of Standard Types,
AUTOSAR_SWS_StandardTypes.pdf
- [10] Specification of C Implementation Rules,
AUTOSAR_TR_CImplementationRules.pdf

3.2 Related standards and norms

- [11] SAE-J1850 8-bit CRC
- [12] CCITT-FALSE 16-bit CRC. Refer to:

ITU-T Recommendation X.25 (10/96) (Previously "CCITT Recommendation")
SERIES X: DATA NETWORKS AND OPEN SYSTEM COMMUNICATION
Public data networks – Interfaces
Interface between Data Terminal Equipment (DTE) and Data Circuit-terminating
Equipment (DCE) for terminals operating in the packet mode and connected to public
data networks by dedicated circuit

Section 2.2.7.4 "Frame Check Sequence (FCS) field" and Appendix I "Examples of
data link layer transmitted bit patterns by the DCE and the DTE"

http://www.itu.int/rec/dologin_pub.asp?lang=e&id=T-REC-X.25-199610-!!!PDF-E&type=items

[13] IEEE 802.3 Ethernet 32-bit CRC

[14] “32-Bit Cyclic Redundancy Codes for Internet Applications” [Koopman 2002]

4 Constraints and assumptions

4.1 Limitations

No known limitations.

4.2 Applicability to car domains

No restrictions.

5 Dependencies to other modules

5.1 File structure

[SWS_Crc_00024] [The Crc module shall provide the following files:

- C file `Crc_xxx.c` containing parts of CRC code
- An API interface `Crc.h` providing the function prototypes to access the library CRC functions
- A header file `Crc_Cfg.h` providing specific parameters for the CRC.

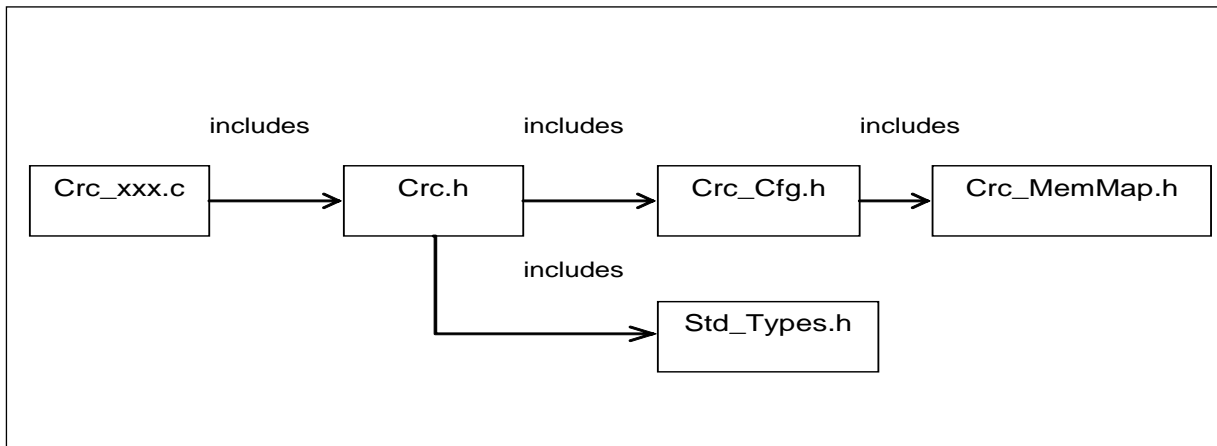

Figure 1: File structure

] ()

[SWS_Crc_00022] [The Crc module shall comply with the following include file structure:

- `Crc.h` shall include `Crc_Cfg.h`, `Std_Types.h` and `Crc_MemMap.h`
- `Crc_xxx.c` shall include `Crc.h`] ()

[SWS_Crc_00023] [Users of the Crc module (e.g. NVRAM Manager) shall only include `Crc.h`] ()

6 Requirements traceability

Requirement	Description	Satisfied by
-	-	SWS_Crc_00009
-	-	SWS_Crc_00010
-	-	SWS_Crc_00013
-	-	SWS_Crc_00014
-	-	SWS_Crc_00015
-	-	SWS_Crc_00016
-	-	SWS_Crc_00018
-	-	SWS_Crc_00019
-	-	SWS_Crc_00020
-	-	SWS_Crc_00021
-	-	SWS_Crc_00022
-	-	SWS_Crc_00023
-	-	SWS_Crc_00024
-	-	SWS_Crc_00030
-	-	SWS_Crc_00031
-	-	SWS_Crc_00032
-	-	SWS_Crc_00033
-	-	SWS_Crc_00040
-	-	SWS_Crc_00041
-	-	SWS_Crc_00042
-	-	SWS_Crc_00043
-	-	SWS_Crc_00044
-	-	SWS_Crc_00045
-	-	SWS_Crc_00050
-	-	SWS_Crc_00052
-	-	SWS_Crc_00053
-	-	SWS_Crc_00054
-	-	SWS_Crc_00055
-	-	SWS_Crc_00058
-	-	SWS_Crc_00059
-	-	SWS_Crc_00060
BSW00420	-	SWS_Crc_00051
BSW00421	-	SWS_Crc_00051
BSW00431	-	SWS_Crc_00051
BSW00434	-	SWS_Crc_00051
BSW324	-	SWS_Crc_00051
SRS_BSW_00004	All Basic SW Modules shall perform a pre-	SWS_Crc_00005

	processor check of the versions of all imported include files	
SRS_BSW_00005	Modules of the μ C Abstraction Layer (MCAL) may not have hard coded horizontal interfaces	SWS_Crc_00051
SRS_BSW_00006	The source code of software modules above the μ C Abstraction Layer (MCAL) shall not be processor and compiler dependent.	SWS_Crc_00051
SRS_BSW_00007	All Basic SW Modules written in C language shall conform to the MISRA C 2004 Standard.	SWS_Crc_00051
SRS_BSW_00009	All Basic SW Modules shall be documented according to a common standard.	SWS_Crc_00051
SRS_BSW_00010	The memory consumption of all Basic SW Modules shall be documented for a defined configuration for all supported platforms.	SWS_Crc_00051
SRS_BSW_00101	The Basic Software Module shall be able to initialize variables and hardware in a separate initialization function	SWS_Crc_00051
SRS_BSW_00160	Configuration files of AUTOSAR Basic SW module shall be readable for human beings	SWS_Crc_00051
SRS_BSW_00161	The AUTOSAR Basic Software shall provide a microcontroller abstraction layer which provides a standardized interface to higher software layers	SWS_Crc_00051
SRS_BSW_00162	The AUTOSAR Basic Software shall provide a hardware abstraction layer	SWS_Crc_00051
SRS_BSW_00164	The Implementation of interrupt service routines shall be done by the Operating System, complex drivers or modules	SWS_Crc_00051
SRS_BSW_00168	SW components shall be tested by a function defined in a common API in the Basis-SW	SWS_Crc_00051
SRS_BSW_00170	The AUTOSAR SW Components shall provide information about their dependency from faults, signal qualities, driver demands	SWS_Crc_00051
SRS_BSW_00172	The scheduling strategy that is built inside the Basic Software Modules shall be compatible with the strategy used in the system	SWS_Crc_00051
SRS_BSW_00302	All AUTOSAR Basic Software Modules shall only export information needed by other modules	SWS_Crc_00051
SRS_BSW_00304	All AUTOSAR Basic Software Modules shall use the following data types instead of native C data types	SWS_Crc_00051
SRS_BSW_00305	Data types naming convention	SWS_Crc_00051
SRS_BSW_00306	AUTOSAR Basic Software Modules shall be compiler and platform independent	SWS_Crc_00051
SRS_BSW_00307	Global variables naming convention	SWS_Crc_00051
SRS_BSW_00308	AUTOSAR Basic Software Modules shall not define global data in their header files, but in the C file	SWS_Crc_00051
SRS_BSW_00309	All AUTOSAR Basic Software Modules shall indicate all global data with read-only purposes	SWS_Crc_00051

	by explicitly assigning the const keyword	
SRS_BSW_00312	Shared code shall be reentrant	SWS_Crc_00051
SRS_BSW_00314	All internal driver modules shall separate the interrupt frame definition from the service routine	SWS_Crc_00051
SRS_BSW_00321	The version numbers of AUTOSAR Basic Software Modules shall be enumerated according specific rules	SWS_Crc_00051
SRS_BSW_00323	All AUTOSAR Basic Software Modules shall check passed API parameters for validity	SWS_Crc_00051
SRS_BSW_00325	The runtime of interrupt service routines and functions that are running in interrupt context shall be kept short	SWS_Crc_00051
SRS_BSW_00326	-	SWS_Crc_00051
SRS_BSW_00327	Error values naming convention	SWS_Crc_00051
SRS_BSW_00328	All AUTOSAR Basic Software Modules shall avoid the duplication of code	SWS_Crc_00051
SRS_BSW_00330	It shall be allowed to use macros instead of functions where source code is used and runtime is critical	SWS_Crc_00051
SRS_BSW_00331	All Basic Software Modules shall strictly separate error and status information	SWS_Crc_00051
SRS_BSW_00333	For each callback function it shall be specified if it is called from interrupt context or not	SWS_Crc_00051
SRS_BSW_00334	All Basic Software Modules shall provide an XML file that contains the meta data	SWS_Crc_00051
SRS_BSW_00335	Status values naming convention	SWS_Crc_00051
SRS_BSW_00336	Basic SW module shall be able to shutdown	SWS_Crc_00051
SRS_BSW_00337	Classification of development errors	SWS_Crc_00051
SRS_BSW_00338	-	SWS_Crc_00051
SRS_BSW_00339	Reporting of production relevant error status	SWS_Crc_00051
SRS_BSW_00341	Module documentation shall contains all needed informations	SWS_Crc_00051
SRS_BSW_00342	It shall be possible to create an AUTOSAR ECU out of modules provided as source code and modules provided as object code, even mixed	SWS_Crc_00051
SRS_BSW_00343	The unit of time for specification and configuration of Basic SW modules shall be preferably in physical time unit	SWS_Crc_00051
SRS_BSW_00344	BSW Modules shall support link-time configuration	SWS_Crc_00051
SRS_BSW_00347	A Naming separation of different instances of BSW drivers shall be in place	SWS_Crc_00051
SRS_BSW_00348	All AUTOSAR standard types and constants shall be placed and organized in a standard type header file	SWS_Crc_00051
SRS_BSW_00350	All AUTOSAR Basic Software Modules shall apply a specific naming rule for enab-	SWS_Crc_00051

	ling/disabling the detection and reporting of development errors	
SRS_BSW_00353	All integer type definitions of target and compiler specific scope shall be placed and organized in a single type header	SWS_Crc_00051
SRS_BSW_00355	-	SWS_Crc_00051
SRS_BSW_00358	The return type of init() functions implemented by AUTOSAR Basic Software Modules shall be void	SWS_Crc_00051
SRS_BSW_00359	All AUTOSAR Basic Software Modules callback functions shall avoid return types other than void if possible	SWS_Crc_00051
SRS_BSW_00360	AUTOSAR Basic Software Modules callback functions are allowed to have parameters	SWS_Crc_00051
SRS_BSW_00361	All mappings of not standardized keywords of compiler specific scope shall be placed and organized in a compiler specific type and keyword header	SWS_Crc_00051
SRS_BSW_00369	All AUTOSAR Basic Software Modules shall not return specific development error codes via the API	SWS_Crc_00051
SRS_BSW_00370	-	SWS_Crc_00051
SRS_BSW_00371	The passing of function pointers as API parameter is forbidden for all AUTOSAR Basic Software Modules	SWS_Crc_00051
SRS_BSW_00373	The main processing function of each AUTOSAR Basic Software Module shall be named according the defined convention	SWS_Crc_00051
SRS_BSW_00375	Basic Software Modules shall report wake-up reasons	SWS_Crc_00051
SRS_BSW_00376	-	SWS_Crc_00051
SRS_BSW_00378	AUTOSAR shall provide a boolean type	SWS_Crc_00051
SRS_BSW_00383	The Basic Software Module specifications shall specify which other configuration files from other modules they use at least in the description	SWS_Crc_00051
SRS_BSW_00384	The Basic Software Module specifications shall specify at least in the description which other modules they require	SWS_Crc_00051
SRS_BSW_00385	List possible error notifications	SWS_Crc_00051
SRS_BSW_00386	The BSW shall specify the configuration for detecting an error	SWS_Crc_00051
SRS_BSW_00387	-	SWS_Crc_00051
SRS_BSW_00388	Containers shall be used to group configuration parameters that are defined for the same object	SWS_Crc_00051
SRS_BSW_00389	Containers shall have names	SWS_Crc_00051
SRS_BSW_00395	The Basic Software Module specifications shall list all configuration parameter dependencies	SWS_Crc_00051
SRS_BSW_00398	The link-time configuration is achieved on object code basis in the stage after compiling and befo-	SWS_Crc_00051

	re linking	
SRS_BSW_00399	Parameter-sets shall be located in a separate segment and shall be loaded after the code	SWS_Crc_00051
SRS_BSW_00400	Parameter shall be selected from multiple sets of parameters after code has been loaded and started	SWS_Crc_00051
SRS_BSW_00401	Documentation of multiple instances of configuration parameters shall be available	SWS_Crc_00051
SRS_BSW_00402	Each module shall provide version information	SWS_Crc_00005
SRS_BSW_00404	BSW Modules shall support post-build configuration	SWS_Crc_00051
SRS_BSW_00405	BSW Modules shall support multiple configuration sets	SWS_Crc_00051
SRS_BSW_00406	A static status variable denoting if a BSW module is initialized shall be initialized with value 0 before any APIs of the BSW module is called	SWS_Crc_00051
SRS_BSW_00407	Each BSW module shall provide a function to read out the version information of a dedicated module implementation	SWS_Crc_00011, SWS_Crc_00017
SRS_BSW_00409	All production code error ID symbols are defined by the Dem module and shall be retrieved by the other BSW modules from Dem configuration	SWS_Crc_00051
SRS_BSW_00410	Compiler switches shall have defined values	SWS_Crc_00051
SRS_BSW_00411	All AUTOSAR Basic Software Modules shall apply a naming rule for enabling/disabling the existence of the API	SWS_Crc_00011, SWS_Crc_00017
SRS_BSW_00412	References to c-configuration parameters shall be placed into a separate h-file	SWS_Crc_00051
SRS_BSW_00414	Init functions shall have a pointer to a configuration structure as single parameter	SWS_Crc_00051
SRS_BSW_00415	Interfaces which are provided exclusively for one module shall be separated into a dedicated header file	SWS_Crc_00051
SRS_BSW_00416	The sequence of modules to be initialized shall be configurable	SWS_Crc_00051
SRS_BSW_00417	Software which is not part of the SW-C shall report error events only after the DEM is fully operational.	SWS_Crc_00051
SRS_BSW_00422	Pre-de-bouncing of error status information is done within the DEM	SWS_Crc_00051
SRS_BSW_00423	BSW modules with AUTOSAR interfaces shall be describable with the means of the SW-C Template	SWS_Crc_00051
SRS_BSW_00424	BSW module main processing functions shall not be allowed to enter a wait state	SWS_Crc_00051
SRS_BSW_00425	The BSW module description template shall provide means to model the defined trigger conditions of schedulable objects	SWS_Crc_00051
SRS_BSW_00427	ISR functions shall be defined and documented	SWS_Crc_00051

	in the BSW module description template	
SRS_BSW_00428	A BSW module shall state if its main processing function(s) has to be executed in a specific order or sequence	SWS_Crc_00051
SRS_BSW_00429	BSW modules shall be only allowed to use OS objects and/or related OS services	SWS_Crc_00051
SRS_BSW_00432	Modules should have separate main processing functions for read/receive and write/transmit data path	SWS_Crc_00051
SRS_BSW_00433	Main processing functions are only allowed to be called from task bodies provided by the BSW Scheduler	SWS_Crc_00051
SRS_LIBS_08525	The CRC library shall support the standard generator polynomials	SWS_Crc_00002, SWS_Crc_00003, SWS_Crc_00056, SWS_Crc_00057

7 Functional specification

7.1 Basic Concepts of CRC Codes

7.1.1 Mathematical Description

Let D be a bitwise representation of data with a total number of n bit, i.e.

$$D = (d_{n-1}, d_{n-2}, d_{n-3}, \dots, d_1, d_0),$$

with $d_0, d_1, \dots = 0b, 1b$. The corresponding *Redundant Code* C is represented by $n+k$ bit as

$$C = (D, R) = (d_{n-1}, d_{n-2}, d_{n-3}, \dots, d_2, d_1, d_0, r_{k-1}, \dots, r_2, r_1, r_0)$$

with $r_0, r_1, \dots = 0b, 1b$ and $R = (r_{k-1}, \dots, r_2, r_1, r_0)$ The code is simply a concatenation of the data and the redundant part. (For our application, we will chose $k = 16, 32$ and n as a multiple of 16 resp. 32).

CRC-Algorithms are related to *polynomials* with coefficients in the finite *field of two element*, using arithmetic operations \oplus and $*$ according to the following tables.

The \oplus operation is identified as the binary operation *exclusive-or*, that is usually available in the ALU of any CPU.

\oplus	0b	1b
0b	0b	1b
1b	1b	0b

*	0b	1b
0b	0b	0b
1b	0b	1b

For simplicity, we will write ab instead of $a*b$

We introduce some examples for *polynomials* with coefficients in the *field of two elements* and give the simplified notation of it.

$$(ex. 1) \quad p_1(X) = 1b X^3 + 0b X^2 + 1b X^1 + 0b X^0 = X^3 + X$$

$$(ex. 2) \quad p_2(X) = 1b X^2 + 1b X^1 + 1b X^0 = X^2 + X^1 + 1b$$

Any code word, represented by $n+k$ bit can be mapped to a polynomial of order $n+k-1$ with coefficients in the field of two elements. We use the intuitive mapping of the bits i.e.

$$C(X) = d_{n-1}X^{k+n-1} + d_{n-2}X^{k+n-2} + \dots + d_2X^{k+2} + d_1X^{k+1} + d_0 X^k + r_{k-1}X^{k-1} + r_{k-2}X^{k-2} + \dots + r_1 X + r_0$$

$$C(X) = X^k (d_{n-1}X^{n-1} + d_{n-2}X^{n-2} + \dots + d_2X^2 + d_1X^1 + d_0) + r_{k-1}X^{k-1} + r_{k-2}X^{k-2} + \dots + r_1 X + r_0$$

$$C(X) = X^k D(X) \oplus R(X)$$

This mapping is one-to-one.

A certain space CRC_G of *Cyclic Redundant Code Polynomials* is defined to be a multiple of a given *Generator Polynomial* $G(X) = X^k + g_{k-1} X^{k-1} + g_{k-2} X^{k-2} + \dots + g_2 X^2 + g_1 X + g_0$. By definition, for any code polynomial $C(X)$ in CRC_G there is a polynomial $M(X)$ with

$$C(X) = G(X) M(X).$$

For a fixed irreducible (i.e. prime-) polynomial $G(X)$, the mapping $M(X) \rightarrow C(X)$ is one-to-one. Now, how are data of a given codeword verified? This is basically a division of polynomials, using the *Euclidian Algorithm*. In practice, we are not interested in $M(X)$, but in the *remainder* of the division, $C(X) \bmod G(X)$. For a correct code word C , this remainder has to be *zero*, $C(X) \bmod G(X) = 0$. If this is not the case – there is an error in the codeword. Given $G(X)$ has some additional algebraic properties, one can determine the error-location and correct the codeword.

Calculating the code word from the data can also be done with the Euclidian Algorithm. For a given data polynomial $D(x) = d_{n-1}X^{n-1} + d_{n-2}X^{n-2} + \dots + d_1X^1 + d_0$ and the corresponding code polynomial $C(X)$ we have

$$C(X) = X^k D(X) \oplus R(X) = M(X) G(X)$$

Performing the operation “mod $G(X)$ ” on both sides, one obtains

$$0 = C(X) \bmod G(X) = [X^k D(X)] \bmod G(X) \oplus R(X) \bmod G(X) \quad (*)$$

We denote that the order of the Polynomial $R(X)$ is less than the order of $G(X)$, so the modulo division gives zero with remainder $R(X)$:

$$R(X) \bmod G(X) = R(X).$$

For polynomial $R(X)$ with coefficients in the finite field with two elements we have the remarkable property $R(X) + R(X) = 0$. If we add $R(X)$ on both sides of equation (*) we obtain

$$R(X) = X^k D(X) \bmod G(X).$$

The important implication is that the redundant part of the requested code can be determined by using the Euclidian Algorithm for polynomials. At present, any CRC calculation method is a more or less sophisticated variation of this basic algorithm.

Up to this point, the propositions on CRC Codes are summarized as follows:

1. The construction principle of CRC Codes is based on polynomials with coefficients in the finite field of two elements. The \oplus operation of this field is identical to the binary operation “xor” (exclusive or)
2. There is a natural mapping of bit-sequences into this space of polynomials.

3. Both calculation and verification of the CRC code polynomial is based on division modulo a given generator polynomial.
4. This generator polynomial has to have certain algebraic properties in order to achieve error-detection and eventually error-correction.

7.1.2 Euclidian Algorithm for Binary Polynomials and Bit-Sequences

Given a Polynomial $P_n(X) = p_n X^n + p_{n-1} X^{n-1} + \dots + p_2 X^2 + p_1 X + p_0$ with coefficients in the finite field of two elements. Let $Q(X) = X^k + q_{k-1} X^{k-1} + q_{k-2} X^{k-2} + \dots + q_2 X^2 + q_1 X + q_0$ be another polynomial of exact order $k > 0$. Let $R_n(X)$ be the remainder of the polynomial division of maximum order $k-1$ and $M_n(X)$ corresponding so that

$$R_n(X) \oplus M_n(X) Q(X) = P_n(X).$$

Euclidian Algorithm - Recursive

(Termination of recursion)

If $n < k$, then choose $R_n(X) = P_n(X)$ and $M_n = 0$.

(Recursion $n+1 \rightarrow n$)

Let $P_{n+1}(X)$ be of maximum order $n+1$.

If $n+1 \geq k$ calculate $P_n(X) = P_{n+1}(X) - p_{n+1} Q(X) X^{n-k+1}$. This polynomial is of maximum order n . Then

$$P_{n+1}(X) \bmod Q(X) = P_n(X) \bmod Q(X).$$

Proof of recursion

Choose $R_{n+1}(X) = P_{n+1}(X) \bmod Q(X)$ and $M_{n+1}(X)$ so that

$$R_{n+1}(X) \oplus M_{n+1}(X) Q(X) = P_{n+1}(X).$$

Then $R_{n+1}(X) - R_n(X) = P_{n+1}(X) - M_{n+1}(X) Q(X) - P_n(X) \oplus M_n(X) Q(X)$.

With $P_{n+1}(X) - P_n(X) = p_{n+1} Q(X) X^{n-k+1}$ we obtain

$$R_{n+1}(X) - R_n(X) = p_{n+1} Q(X) X^{n-k+1} + M_n(X) Q(X) - M_{n+1}(X) Q(X)$$

$$R_{n+1}(X) - R_n(X) = Q(X) [p_{n+1} X^{n-k+1} + M_n(X) - M_{n+1}(X)]$$

On the left side, there is a polynomial of maximum order $k-1$. On the right side $Q(X)$ is of exact order k . This implies that both sides are trivial and equal to zero. One obtains

$$R_{n+1}(X) = R_n(X) \tag{1}$$

$$M_{n+1}(X) = M_n(X) + p_{n+1} X^{n-k+1} \tag{2}$$

(end of proof)

Example

$$\begin{aligned}
 P(X) &= P_4(X) = X^4 + X^2 + X + 1b; \quad Q(X) = X^2 + X + 1b; \quad n = 4; \quad k = 2 \\
 P_3(X) &= X^4 + X^2 + X + 1b - 1b(X^2 + X + 1b) \quad X^2 = X^3 + X + 1b. \\
 P_2(X) &= X^3 + X + 1b - 1b X (X^2 + X + 1b) = X^2 + 1b. \\
 P_1(X) &= X^2 + 1 - 1b (X^2 + X + 1) = X \\
 R(X) &= P(X) \bmod Q(X) = R_1(X) = P_1(X) = X.
 \end{aligned}$$

7.1.3 CRC calculation, Variations and Parameter

Based on the Euclidian Algorithm, some variations have been developed in order to improve the calculation performance. All these variations do not improve the capability to detect or correct errors – the so-called Hamming Distance of the resulting code is determined only by the generator polynomial. Variations simply optimize for different implementing ALUs.

CRC-Calculation methods are characterized as follows:

1. Rule for Mapping of Data to a bit sequence $(d_{n-1}, d_{n-2}, d_{n-3}, \dots, d_1, d_0)$ and the corresponding data polynomial $D(X)$ (standard or reflected data).
2. Generator polynomial $G(X)$
3. Start value and corresponding Polynomial $S(X)$
4. Appendix $A(X)$, also called XOR-value for modifying the final result.
5. Rule for mapping the resulting CRC-remainder $R(X)$ to codeword. (Standard or reflected data)

The calculation itself is organized in the following steps

- Map Data to $D(X)$
- Perform Euclidian Algorithm on $X^k D(X) + X^{n-k-1} S(X) + A(X)$ and determine $R(X) = [X^k D(X) + X^{n-k-1} S(X) + A(X)] \bmod G(X)$
- Map $D(X), R(X)$ to codeword

7.2 Standard parameters

This section gives a rough overview on the standard parameters that are commonly used for 8-bit, 16-bit and 32-bit CRC calculation.

- CRC result width: Defines the result data width of the CRC calculation.
- Polynomial: Defines the generator polynomial which is used for the CRC algorithm.
- Initial value: Defines the start condition for the CRC algorithm.
- Input data reflected: Defines whether the bits of each input byte are

reflected before being processed (see definition below).

- **Result data reflected:** Similar to “Input data reflected” this parameter defines whether the bits of the CRC result are reflected (see definition below). The result is reflected over 8-bit for a CRC8, over 16-bit for a CRC16 and over 32-bit for a CRC32.
- **XOR value:** This Value is XORed to the final register value before the value is returned as the official checksum.
- **Check:** This field is a check value that can be used as a weak validator of implementations of the algorithm. The field contains the checksum obtained when the ASCII values '1' '2' '3' '4' '5' '6' '7' '8' '9' corresponding to values 31h 32h 33h 34h 35h 36h 37h 38h 39h is fed through the specified algorithm.
- **Magic check:** The CRC checking process calculates the CRC over the entire data block, including the CRC result. An error-free data block will always result in the unique constant polynomial (magic check) - representing the CRC-result XORed with 'XOR value'- regardless of the data block content.

Example of magic check: calculation of SAE-J1850 CRC8 (see detailed parameters in [SWS_Crc_00030](#)) over data bytes 00h 00h 00h 00h:

- CRC generation: CRC over 00h 00h 00h 00h, start value FFh:
 - CRC-result = 59h
- CRC check: CRC over 00h 00h 00h 00h 59h, start value FFh:
 - CRC-result = 3Bh
 - Magic check = CRC-result XORed with 'XOR value':

C4h	=	3Bh	xor	FFh
-----	---	-----	-----	-----

Data reflection: It is a reflection on a bit basis where data bits are written in the reverse order. The formula is:

$$reflect_n(x) = \sum_{i=0}^{n-1} x_i \times 2^{n-i-1}$$

where x is the data and n the number of data bits.

E.g. The reflection₈ of 2D₁₆ ($n=8$) (00101101₂) is B4₁₆ (10110100₂)

The reflection₁₆ of 12345678₁₆ ($n=16$) (0001 0010 0011 0100 0101 0110 0111 1000₂) is 1E6A2C48₁₆ (0001 1110 0110 1010 0010 1100 0100 1000₂).

The reflection₃₂ of 123456789ABCDEF0 ($n = 32$) (0001 0010 0011 0100 0101 0110 0111 1000 1001 1010 1011 1100 1101 1110 1111 0000₂) is 0F7B3D591E6A2C48₁₆ (0000 1111 0111 1011 0011 1101 0101 1001 0001 1110 0110 1010 0010 1100 0100 1000₂).

The reflection₈ of 123456789ABCDEF0 ($n = 8$) (0001 0010 0011 0100 0101 0110 0111 1000 1001 1010 1011 1100 1101 1110 1111 0000₂) is 84C2A6E195D3B7F0₁₆ (1000 0100 1100 0010 1010 0110 1110 0001 1001 0101 1101 0011 1011 0111 1111 0000₂).

7.2.1 8-bit CRC calculation

7.2.1.1 8-bit SAE J1850 CRC Calculation

[SWS_Crc_00030] [The Crc_CalculateCRC8() function of the CRC module shall implement the CRC8 routine based on the SAE-J1850 CRC8 Standard:

CRC result width:	8 bits
Polynomial:	1Dh
Initial value:	FFh
Input data reflected:	No
Result data reflected:	No
XOR value:	FFh
Check:	4Bh
Magic check:	C4h

] ()

[SWS_Crc_00052] [The Crc_CalculateCRC8() function of the CRC module shall provide the following CRC results:

Data bytes (hexadecimal)									CRC
00	00	00	00						59
F2	01	83							37
0F	AA	00	55						79
00	FF	55	11						B8
33	22	55	AA	BB	CC	DD	EE	FF	CB
92	6B	55							8C
FF	FF	FF	FF						74

] ()

7.2.1.2 8-bit 0x2F polynomial CRC Calculation

[SWS_Crc_00042] [The Crc_CalculateCRC8H2F() function of the CRC module shall implement the CRC8 routine based on the generator polynomial 0x2F:

CRC result width:	8 bits
Polynomial:	2Fh
Initial value:	FFh
Input data reflected:	No
Result data reflected:	No
XOR value:	FFh
Check:	DFh
Magic check:	42h

] ()

[SWS_Crc_00053] [The Crc_CalculateCRC8H2F() function of the CRC module shall provide the following CRC results:

Data bytes (hexadecimal)									CRC
00	00	00	00						12
F2	01	83							C2
0F	AA	00	55						C6
00	FF	55	11						77
33	22	55	AA	BB	CC	DD	EE	FF	11
92	6B	55							33
FF	FF	FF	FF						6C

] ()

7.2.2 16-bit CRC calculation

7.2.2.1 16-bit CCITT-FALSE CRC16

[SWS_Crc_00002] [The CRC module shall implement the CRC16 routine based on the CCITT-FALSE CRC16 Standard:

Note concerning the standard document [8]:

The computed FCS is equal to CRC16 XOR FFFFh when the frame is built (first complement of the CCITT-FALSE CRC16).

For the verification, the CRC16 (CCITT-FALSE) is computed on the same data + FCS, and the resulting value is always 1D0Fh.

Note that, if during the verification, the check would have been done on data + CRC16 (i.e. FCS XOR FFFFh) the resulting value would have been 0000h that is the CCITT-FALSE magic check.

CRC result width:	16 bits
Polynomial:	1021h
Initial value:	FFFFh
Input data reflected:	No

Result data reflected:	No
XOR value:	0000h
Check:	29B1h
Magic check:	0000h

] (SRS_LIBS_08525)

[SWS_Crc_00054] | The Crc_CalculateCRC16() function of the CRC module shall provide the following CRC results:

Data bytes (hexadecimal)									CRC
00	00	00	00						84C0
F2	01	83							D374
0F	AA	00	55						2023
00	FF	55	11						B8F9
33	22	55	AA	BB	CC	DD	EE	FF	F53F
92	6B	55							0745
FF	FF	FF	FF						1D0F

] ()

7.2.3 32-bit CRC calculation

7.2.3.1 32-bit Ethernet CRC Calculation

[SWS_Crc_00003] | The CRC module shall implement the CRC32 routine based on the IEEE-802.3 CRC32 Ethernet Standard:

CRC result width:	32 bits
Polynomial:	04C11DB7h
Initial value:	FFFFFFFFh
Input data reflected:	Yes
Result data reflected:	Yes
XOR value:	FFFFFFFFh
Check:	CBF43926h
Magic check*:	DEBB20E3h

***Important note:** To match the magic check value, the CRC must be appended in little endian format, i.e. low significant byte first. This is due to the reflections of the input and the result.] (SRS_LIBS_08525)

[SWS_Crc_00055] | The Crc_CalculateCRC32() function of the CRC module shall provide the following CRC results:

Data bytes (hexadecimal)									CRC
00	00	00	00						2144DF1C
F2	01	83							24AB9D77
0F	AA	00	55						B6C9B287
00	FF	55	11						32A06212
33	22	55	AA	BB	CC	DD	EE	FF	B0AE863D
92	6B	55							9CDEA29B
FF	FF	FF	FF						FFFFFFFF

| ()

7.2.3.2 32-bit 0xF4ACFB13 polynomial CRC calculation

This 32-bit CRC function is described in [14]. It has an advantage with respect to the Ethernet CRC – it has a Hamming Distance of 6 up to 4kB.

[SWS_Crc_00056] | The CRC module shall implement the CRC32 routine using the 0x1'F4'AC'FB'13 (0xF4'AC'FB'13) polynomial:

CRC result width:	32 bits
Polynomial:	F4'AC'FB'13h
Initial value:	FFFFFFFFh
Input data reflected:	Yes
Result data reflected:	Yes
XOR value:	FFFFFFFFh
Check:	16'97'D0'6Ah
Magic check*:	90'4C'DD'BFh
Hamming distance:	6, up to 4096 bytes (including CRC)

***Important note:** To match the magic check value, the CRC must be appended in little endian format, i.e. low significant byte first. This is due to the reflections of the input and the result.

| (SRS_LIBS_08525)

There are three notations for encoding the polynomial, so to clarify, all three notations are shown:

1	Polynomial as binary	0001`1111`0100`1010`1100`1111`1011`0001`0011
2	Normal representation with high bit	01'F4'AC'FB'13h
3	Normal representation	F4'AC'FB'13h
4	Reversed reciprocal representation (=Koopman representation)	FA'56'7D'89h

Notes:

1. Normal representation with high bit = hex representation of polynomial as binary
2. Normal representation with high bit = Koopman representation * 2 + 1

[SWS_Crc_00057] The Crc_CalculateCRC32P4() function of the CRC module shall provide the following CRC results:

Data bytes (hexadecimal)									CRC
00	00	00	00						6FB32240h
F2	01	83							4F721A25h
0F	AA	00	55						20662DF8h
00	FF	55	11						9BD7996Eh
33	22	55	AA	BB	CC	DD	EE	FF	A65A343Dh
92	6B	55							EE688A78h
FF	FF	FF	FF						FFFFFFFFh

] (SRS_LIBS_08525)

7.3 General behavior

Data blocks are passed to the CRC routines using the parameters “start address”, “size” and “start value”. The return value is the CRC result.

7.4 Error classification

The CRC library functions do not provide any error classification. CRC recalculation and comparison must be done by each module in the upper layer (e.g. NVRAM Manager).

7.5 Error detection

The CRC library functions do not provide any error detection mechanism.

7.6 Error notification

The CRC library functions do not provide any error notification.

7.7 Version check

[SWS_Crc_00005] [`Crc.c` shall check if the correct version of `Crc.h` is included. This shall be done by a preprocessor check of the version number `CRC_MAJOR_VERSION` and `CRC_MINOR_VERSION`.] (SRS_BSW_00402, SRS_BSW_00004)

7.8 Debugging concept

None

8 API specification

8.1 Imported types

In this chapter, all types included from the following files are listed:

[SWS_Crc_00018] [

<i>Module</i>	<i>Imported Type</i>
Std_Types	Std_VersionInfoType

] ()

8.2 Type definitions

None.

8.3 Function definitions

[SWS_Crc_00013] [If CRC routines are to be used as a library, the CRC modules' implementer shall develop the CRC module in a way that only those parts of the CRC code that are used by other modules are linked into the final binary.] ()

[SWS_Crc_00014] [The CRC function (with parameter *Crc_IsFirstCall* = TRUE) shall do the following operations:

1. As 'Initial value' of the CRC computation, uses the attribute 'Initial value' of the polynomial:

$$Crc = PolynomialInitVal$$

2. If the attribute 'Input data reflected' of the polynomial is TRUE, then reflects input data (byte per byte) obtained via parameters *Crc_DataPtr* and *Crc_Length*:

$$Data = reflect_8 (Data) \text{ (in the case 'Input data reflected' is TRUE)}$$

3. Compute the CRC over the data, the last CRC and the CRC polynomial:

$$Crc = f(Data, Crc, Polynomial)$$

4. Execute the XOR operation between *crc* and 'XOR value' of the polynomial:

$$Crc = Crc \wedge PolynomialXorVal$$

5. If the attribute 'Result data reflected' of the polynomial is TRUE, then reflect the CRC (over 8, 16 or 32 bits, depending on the CRC size):

$$Crc = reflect_{Crc\ size} (Crc) \text{ (in the case 'Result data reflected' is TRUE)}$$

6. The CRC is returned:

```
return Crc
```

Steps 2 and 3 are performed as long as data are available

] ()

[SWS_Crc_00041] [The CRC function (with parameter *Crc_IsFirstCall* = FALSE) shall do the following operations:

1. As 'Initial value' of the CRC computation, uses the parameter *Crc_StartValueX* (where X is 8, 8H2F, 16, 32 or P4) that should be the CRC result of the last call. The result is then XORed with 'XOR value' and reflected if 'Result data reflected' of the polynomial is TRUE:

$$Crc = Crc_StartValueX \oplus PolynomialXorVal$$

$Crc = reflect_{Crc\ size}(Crc)$ (in the case 'Result data reflected' is TRUE)

Steps 2 to 6 are identical to **[SWS_Crc_00014]** .] ()

Usage of CRC functions:

For the first or the unique call the user of a CRC function shall:

1. give a pointer to the data (*Crc_DataPtr*)
2. give the number of bytes of data (*Crc_Length*)
3. give the *Crc_StartValueX* parameter a don't care value (the initialization value is known by the chosen algorithm)
4. give the *Crc_IsFirstCall* parameter the value TRUE to inform the library that it is the first or unique call
5. call the CRC function
6. get the CRC

For the subsequent calls the user has to:

1. give a pointer to the data (*Crc_DataPtr*)
2. give the number of bytes of data (*Crc_Length*)
3. give the *Crc_StartValueX* parameter (X is 8, 8H2F, 16 or 32) the CRC result of the previous call
4. give the *Crc_IsFirstCall* parameter the value FALSE to inform the library that it is not the first call
5. call the CRC function
6. get the CRC

Example 1: calculation of CRC8: calculation of CRC8 SAEJ1850, over one of test patterns defined by SAE J1850 specification (00h, FFh, 55h, 11h results with CRC B8h)

- If done in one step:

```
uint8 Array[4] = {0x00, 0xFF, 0x55, 0x11};
uint8 ignored_val = 0x001; /* any value, it is ignored */
```

```
uint8 resultSAE = Crc_CalculateCRC8(&Array[0], 4, ignored_val, TRUE);
```

resultSAE shall be equal to B8h

- If done in several steps:

```
uint8 Array[4] = {0x00, 0xFF, 0x55, 0x11};
uint8 ignored_val = 0x001; /* any value, it is ignored */

uint8 resultSAE = Crc_CalculateCRC8(&Array[0], 2, ignored_val,
    TRUE);
resultSAE = Crc_CalculateCRC8(&Array[2], 1, resultSAE, FALSE);
resultSAE = Crc_CalculateCRC8(&Array[3], 1, resultSAE, FALSE);
```

resultSAE shall be also equal to B8h

Example 2: calculation of CRC8: calculation of that is *not* compatible with SAE J1850, but it is compatible with AUTOSAR releases before R4.0:

- If done in one step:

```
uint8 Array[4] = {0x00, 0xFF, 0x55, 0x11};

/* The first call also gets IsFirstCall set to FALSE, and 0xFF as
start value, which is immediately XORed with 0xFF by CalculateCRC8,
resulting with start value equal to 0x00. */
uint8 resultRel3 = Crc_CalculateCRC8(&Array[0], 4, 0xFF, FALSE);

/* The last XORing must be negated by the caller, to come to 0x00 XOR
value. */
resultRel3 = resultR3 ^ 0xFF;
```

resultRel3 contains the same value as computed by AUTOSAR R3.2 CRC8.

- If done in several steps:

```
uint8 Array[4] = {0x00, 0xFF, 0x55, 0x11};

/* The first call also gets IsFirstCall set to FALSE, and 0xFF as
start value, which is immediately XORed with 0xFF by CalculateCRC8,
resulting with start value equal to 0x00. */
uint8 resultRel3 = Crc_CalculateCRC8(&Array[0], 2, 0xFF, FALSE);

resultRel3 = Crc_CalculateCRC8(&Array[2], 1, resultRel3, FALSE);
resultRel3 = Crc_CalculateCRC8(&Array[3], 1, resultRel3, FALSE);

/* The last XORing must be negated by the caller, to come to 0x00 XOR
value. */
resultRel3 = resultR3 ^ 0xFF;
```

resultRel3 contains also the same value as computed by AUTOSAR R3.2 CRC8.

Example 3: calculation of CRC32 Ethernet Standard (see detailed parameters in [SWS_Crc_00003](#)) over data bytes 01h 02h 03h 04h 05h 06h 07h 08h:

- In one function call, CRC over 01h 02h 03h 04h 05h 06h 07h 08h, start value FFFFFFFFh:
 - CRC-result = 3FCA88C5h (final value)
- In two function calls:

- CRC over 01h 02h 03h 04h, start value FFFFFFFFh:
 - CRC-result of first call = B63CFBCDh (intermediate value)
- CRC over 05h 06h 07h 08h, start value: B63CFBCDh xor XOR value (FFFFFFFh) = 49C30432h and after reflection: 4C20C392h
 - CRC-result of final call = 3FCA88C5h (final value)

The following C-code example shows that the caller modifies the start value by using the previous result (without any rework) and indicates that it is no more the first call:

```
InterResult = Crc_CalculateCRC32(&Array12345678[0], 4, 0xFFFFFFFF, TRUE);
result = Crc_CalculateCRC32(&Array12345678[4], 4, InterResult, FALSE);
```

8.3.1 8-bit CRC Calculation

8.3.1.1 8-bit SAE J1850 CRC Calculation

[SWS_Crc_00031] [

Service name:	Crc_CalculateCRC8	
Syntax:	<pre>uint8 Crc_CalculateCRC8(const uint8* Crc_DataPtr, uint32 Crc_Length, uint8 Crc_StartValue8, boolean Crc_IsFirstCall)</pre>	
Service ID[hex]:	0x01	
Sync/Async:	Synchronous	
Reentrancy:	Reentrant	
Parameters (in):	Crc_DataPtr	Pointer to start address of data block to be calculated.
	Crc_Length	Length of data block to be calculated in bytes.
	Crc_StartValue8	Start value when the algorithm starts.
	Crc_IsFirstCall	TRUE: First call in a sequence or individual CRC calculation; start from initial value, ignore Crc_StartValue8. FALSE: Subsequent call in a call sequence; Crc_StartValue8 is interpreted to be the return value of the previous function call.
Parameters (in-out):	None	
Parameters (out):	None	
Return value:	uint8	8 bit result of CRC calculation.
Description:	This service makes a CRC8 calculation on Crc_Length data bytes, with SAE J1850 parameters	

] ()

[SWS_Crc_00032] [The function `Crc_CalculateCRC8` shall perform a CRC8 calculation on `Crc_Length` data bytes, pointed to by `Crc_DataPtr`, with the starting value of `Crc_StartValue8`.] ()

[SWS_Crc_00033] [If the CRC calculation within the function `Crc_CalculateCRC8` is performed by hardware, then the CRC module's implementer shall ensure reentrancy of this function by implementing a (software based) locking mechanism.] ()

Note: If large data blocks have to be calculated (>32 bytes, depending on performance of processor platform), the table based calculation method should be configured for the function `Crc_CalculateCRC8` in order to decrease the calculation time.

The function `Crc_CalculateCRC8` requires specification of configuration parameters defined in ECUC_Crc_00006.

8.3.1.2 8-bit 0x2F polynomial CRC Calculation

[SWS_Crc_00043]

Service name:	Crc_CalculateCRC8H2F	
Syntax:	<pre>uint8 Crc_CalculateCRC8H2F(const uint8* Crc_DataPtr, uint32 Crc_Length, uint8 Crc_StartValue8H2F, boolean Crc_IsFirstCall)</pre>	
Service ID[hex]:	0x05	
Sync/Async:	Synchronous	
Reentrancy:	Reentrant	
Parameters (in):	Crc_DataPtr	Pointer to start address of data block to be calculated.
	Crc_Length	Length of data block to be calculated in bytes.
	Crc_StartValue8H2F	Start value when the algorithm starts.
	Crc_IsFirstCall	TRUE: First call in a sequence or individual CRC calculation; start from initial value, ignore Crc_StartValue8H2F. FALSE: Subsequent call in a call sequence; Crc_StartValue8H2F is interpreted to be the return value of the previous function call.
Parameters (in-out):	None	
Parameters (out):	None	
Return value:	uint8	8 bit result of CRC calculation.
Description:	This service makes a CRC8 calculation with the Polynomial 0x2F on Crc_Length	

] ()

[SWS_Crc_00044] [The function `Crc_CalculateCRC8H2F` shall perform a CRC8 calculation with the polynomial 0x2F on `Crc_Length` data bytes, pointed to by `Crc_DataPtr`, with the starting value of `Crc_StartValue8H2F`.] ()

[SWS_Crc_00045] [If the CRC calculation within the function `Crc_CalculateCRC8H2F` is performed by hardware, then the CRC module's implementer shall ensure reentrancy of this function by implementing a (software based) locking mechanism.] ()

Note: If large data blocks have to be calculated (>32 bytes, depending on performance of processor platform), the table based calculation method should be configured for the function `Crc_CalculateCRC8H2F` in order to decrease the calculation time.

The function `Crc_CalculateCRC8H2F` requires specification of configuration parameters defined ECUC_Crc_00006.

8.3.2 16-bit CRC Calculation

8.3.2.1 16-bit CCITT-FALSE CRC16

[SWS_Crc_00019]

Service name:	Crc_CalculateCRC16	
Syntax:	<pre>uint16 Crc_CalculateCRC16(const uint8* Crc_DataPtr, uint32 Crc_Length, uint16 Crc_StartValue16, boolean Crc_IsFirstCall)</pre>	
Service ID[hex]:	0x02	
Sync/Async:	Synchronous	
Reentrancy:	Reentrant	
Parameters (in):	Crc_DataPtr	Pointer to start address of data block to be calculated.
	Crc_Length	Length of data block to be calculated in bytes.
	Crc_StartValue16	Start value when the algorithm starts.
	Crc_IsFirstCall	TRUE: First call in a sequence or individual CRC calculation; start from initial value, ignore Crc_StartValue16. FALSE: Subsequent call in a call sequence; Crc_StartValue16 is interpreted to be the return value of the previous function call.
Parameters (in-out):	None	
Parameters (out):	None	
Return value:	uint16	16 bit result of CRC calculation.
Description:	This service makes a CRC16 calculation on Crc_Length data bytes.	

] ()

[SWS_Crc_00015] [The function `Crc_CalculateCRC16` shall perform a CRC16 calculation on `Crc_Length` data bytes, pointed to by `Crc_DataPtr`, with the starting value of `Crc_StartValue16`.] ()

[SWS_Crc_00009] [If the CRC calculation within the function `Crc_CalculateCRC16` is performed by hardware, then the CRC module's implementer shall ensure reentrancy of this function by implementing a (software based) locking mechanism.] ()

Note: If large data blocks have to be calculated (>32 bytes, depending on performance of processor platform), the table based calculation method should be configured for the function `Crc_CalculateCRC16` in order to decrease the calculation time.

The function `Crc_CalculateCRC16` requires specification of configuration parameters defined in ECUC_Crc_00006.

8.3.3 32-bit CRC Calculation

8.3.3.1 32-bit Ethernet CRC Calculation

[SWS_Crc_00020] [

Service name:	Crc_CalculateCRC32	
Syntax:	<pre>uint32 Crc_CalculateCRC32(const uint8* Crc_DataPtr, uint32 Crc_Length, uint32 Crc_StartValue32, boolean Crc_IsFirstCall)</pre>	
Service ID[hex]:	0x03	
Sync/Async:	Synchronous	
Reentrancy:	Reentrant	
Parameters (in):	Crc_DataPtr	Pointer to start address of data block to be calculated.
	Crc_Length	Length of data block to be calculated in bytes.
	Crc_StartValue32	Start value when the algorithm starts.
	Crc_IsFirstCall	TRUE: First call in a sequence or individual CRC calculation; start from initial value, ignore Crc_StartValue32. FALSE: Subsequent call in a call sequence; Crc_StartValue32 is interpreted to be the return value of the previous function call.
Parameters (in-out):	None	
Parameters (out):	None	
Return value:	uint32	32 bit result of CRC calculation.
Description:	This service makes a CRC32 calculation on Crc_Length data bytes.	

] ()

[SWS_Crc_00016] [The function Crc_CalculateCRC32 shall perform a CRC32 calculation on Crc_Length data bytes, pointed to by Crc_DataPtr, with the starting value of Crc_StartValue32.] ()

[SWS_Crc_00010] [If the CRC calculation within the function Crc_CalculateCRC32 is performed by hardware, then the CRC module's implementer shall ensure reentrancy of this function by implementing a (software based) locking mechanism.] ()

Note: If large data blocks have to be calculated (>32 bytes, depending on performance of processor platform), the table based calculation method should be configured for the function Crc_CalculateCRC32 in order to decrease the calculation time.

The function Crc_CalculateCRC32 requires specification of configuration parameters defined in ECUC_Crc_00006.

8.3.3.2 32-bit 0xF4ACFB13 polynomial CRC calculation

[SWS_Crc_00058]

Service name:	Crc_CalculateCRC32P4	
Syntax:	<pre>uint32 Crc_CalculateCRC32P4(const uint8* Crc_DataPtr, uint32 Crc_Length, uint32 Crc_StartValue32, boolean Crc_IsFirstCall)</pre>	
Service ID[hex]:	0x06	
Sync/Async:	Synchronous	
Reentrancy:	Reentrant	
Parameters (in):	Crc_DataPtr	Pointer to start address of data block to be calculated.
	Crc_Length	Length of data block to be calculated in bytes.
	Crc_StartValue32	Start value when the algorithm starts.
	Crc_IsFirstCall	TRUE: First call in a sequence or individual CRC calculation; start from initial value, ignore Crc_StartValue32. FALSE: Subsequent call in a call sequence; Crc_StartValue32 is interpreted to be the return value of the previous function call.
Parameters (in-out):	None	
Parameters (out):	None	
Return value:	uint32	32 bit result of CRC calculation.
Description:	<p>This service makes a CRC32 calculation on Crc_Length data bytes, using the polynomial 0xF4ACFB13.</p> <p>This CRC routine is used by E2E Profile 4.</p>	

] ()

[SWS_Crc_00059] The function Crc_CalculateCRC32P4 shall perform a CRC32 calculation using polynomial 0xF4ACFB13 on Crc_Length data bytes, pointed to by Crc_DataPtr, with the starting value of Crc_StartValue32.] ()

[SWS_Crc_00060] [If the CRC calculation within the function Crc_CalculateCRC32P4 is performed by hardware, then the CRC module's implementer shall ensure reentrancy of this function by implementing a (software based) locking mechanism.] ()

Note: If large data blocks have to be calculated (>32 bytes, depending on performance of processor platform), the (1) hardware supported CRC calculation or (2) table based calculation method, should be configured for the function Crc_CalculateCRC32P4 in order to decrease the calculation time.

The function Crc_CalculateCRC32P4 requires specification of configuration parameters defined in ECUC_Crc_00006.

8.3.4 Crc_GetVersionInfo

[SWS_Crc_00021] [

Service name:	Crc_GetVersionInfo
Syntax:	void Crc_GetVersionInfo(Std_VersionInfoType* Versioninfo)
Service ID[hex]:	0x04
Sync/Async:	Synchronous
Reentrancy:	Reentrant
Parameters (in):	None
Parameters (in-out):	None
Parameters (out):	Versioninfo Pointer to where to store the version information of this module.
Return value:	None
Description:	This service returns the version information of this module.

] ()

[SWS_Crc_00011] [The function Crc_GetVersionInfo shall return the version information of the CRC module. The version information includes:

- Module Id
- Vendor Id
- Vendor specific version numbers (SRS_BSW_00407).] (SRS_BSW_00407, SRS_BSW_00411)

SRS_BSW_00407

[SWS_Crc_00017] [If source code for caller and callee of the function Crc_GetVersionInfo is available, the CRC module should realize this function as a macro, defined in the modules header file.] (SRS_BSW_00407, SRS_BSW_00411)

8.4 Call-back notifications

None.

8.5 Scheduled functions

This chapter lists all functions called directly by the Basic Software Module Scheduler.

The Crc module does not have scheduled functions.

8.6 Expected Interfaces

In this chapter, all interfaces required from other modules are listed.

8.6.1 Mandatory Interfaces

None

8.6.2 Optional Interfaces

None.

8.6.3 Configurable interfaces

None.

9 Sequence diagrams

9.1 Crc_CalculateCRC8()

The following diagram shows the synchronous function call `Crc_CalculateCRC8`.

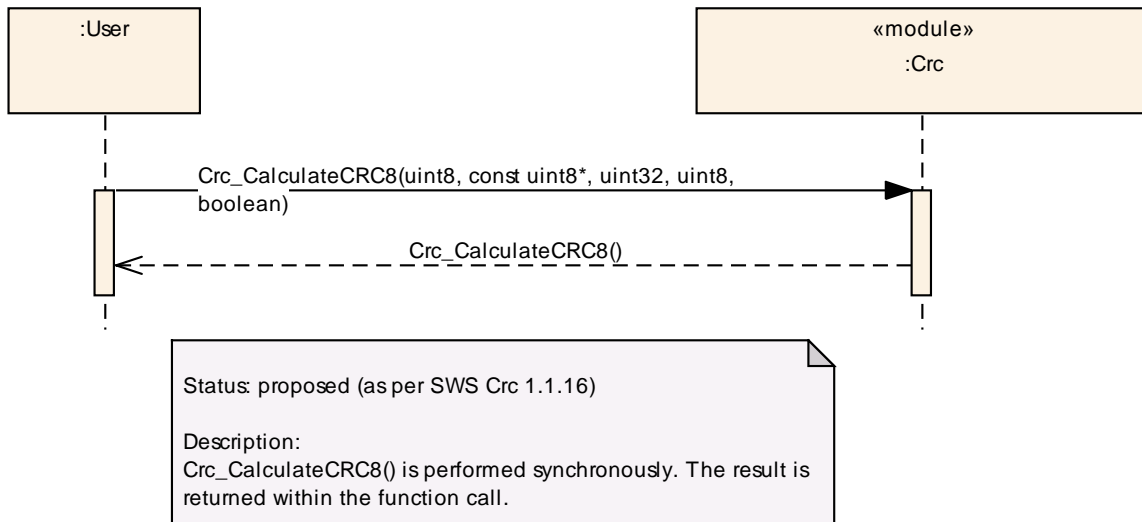

9.2 Crc_CalculateCRC8H2F()

The following diagram shows the synchronous function call `Crc_CalculateCRC8H2F`.

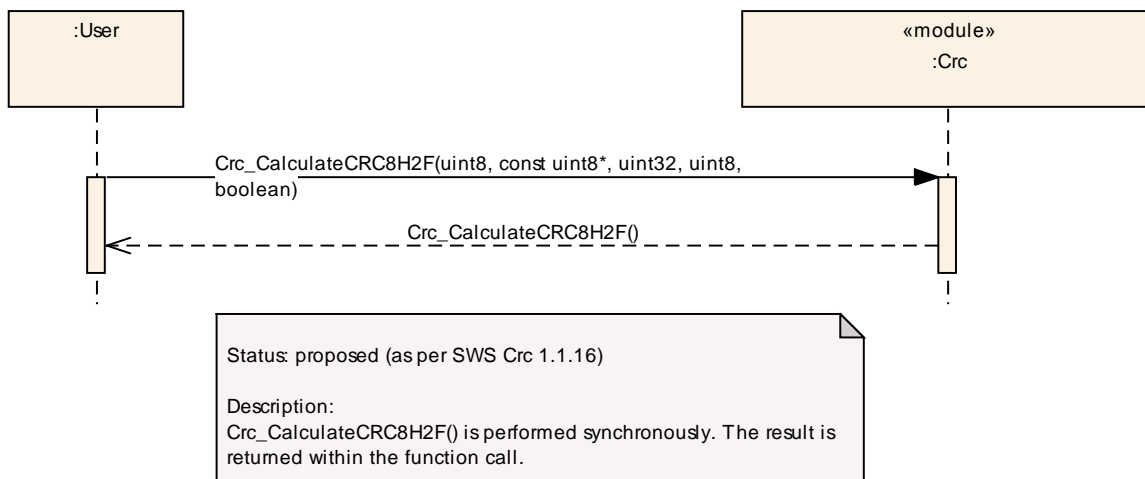

9.3 Crc_CalculateCRC16()

The following diagram shows the synchronous function call `Crc_CalculateCRC16`.

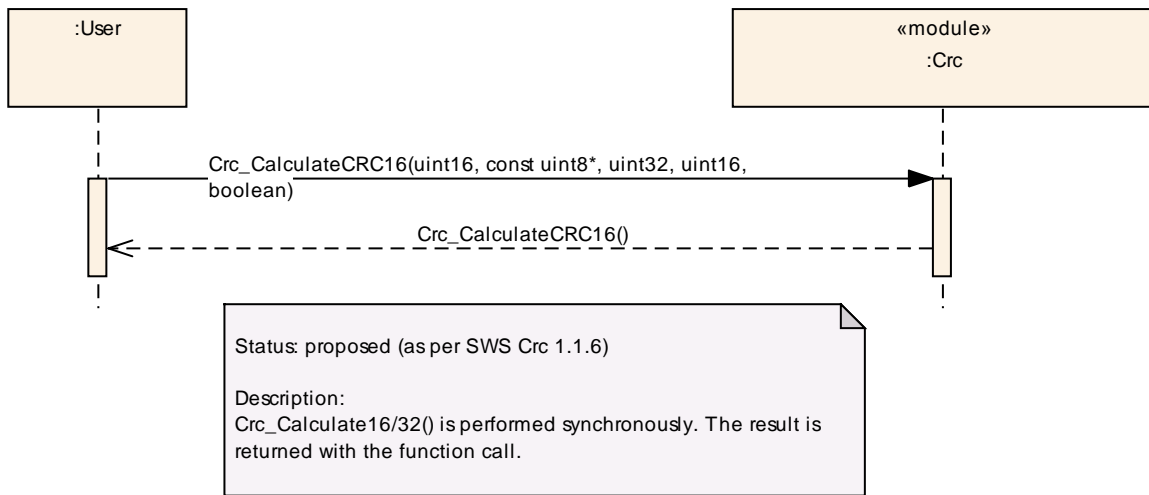

9.4 Crc_CalculateCRC32()

The following diagram shows the synchronous function call `Crc_CalculateCRC32`.

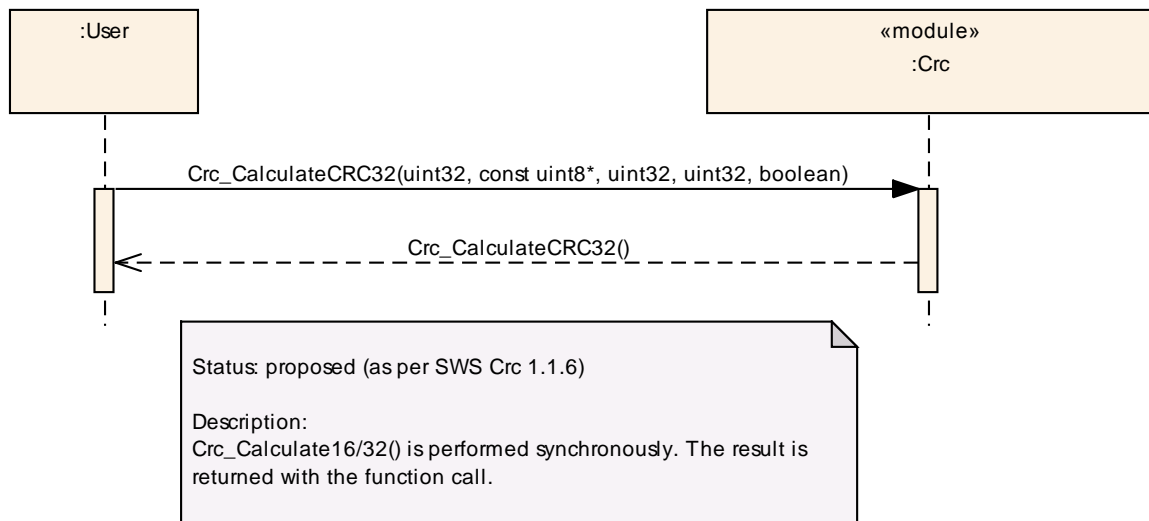

9.5 Crc_CalculateCRC32P4()

The following diagram shows the synchronous function call Crc_CalculateCRC32P4.

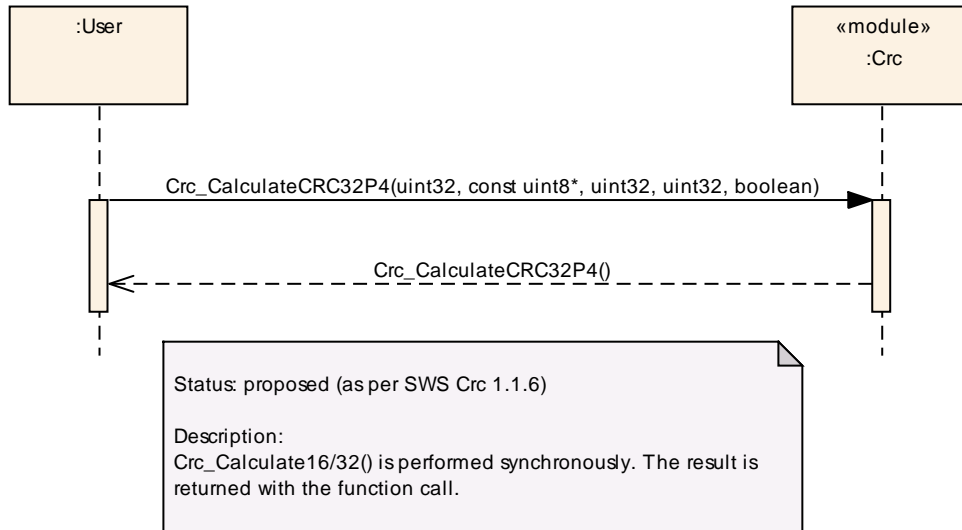

10 Configuration specification

10.1 How to read this chapter

In addition to this section, it is highly recommended to read the documents:

- AUTOSAR Layered Architecture [2]
- AUTOSAR ECU Configuration Specification [5]:
This document describes the AUTOSAR configuration methodology and the AUTOSAR configuration metamodel in detail.

The following is only a short survey of the topic and it will not replace the ECU Configuration Specification document.

10.1.1 Configuration and configuration parameters

Configuration parameters define the variability of the generic part(s) of an implementation of a module. This means that only generic or configurable module implementation can be adapted to the environment (software/hardware) in use during system and/or ECU configuration.

The configuration of parameters can be achieved at different times during the software process: before compile time, before link time or after build time. In the following, the term “configuration class” (of a parameter) shall be used in order to refer to a specific configuration point in time.

10.1.2 Variants

Variants describe sets of configuration parameters. E.g., variant 1: only pre-compile time configuration parameters; variant 2: mix of pre-compile- and post build time-configuration parameters. In one variant a parameter can only be of one configuration class.

10.1.3 Containers

Containers structure the set of configuration parameters. This means:

- *all* configuration parameters are kept in containers.
- (sub-) containers can reference (sub-) containers. It is possible to assign a multiplicity to these references. The multiplicity then defines the possible number of instances of the contained parameters.

10.2 Containers and configuration parameters

The following chapters summarize all configuration parameters. The detailed meanings of the parameters are described in Chapters 7 and Chapter 8.

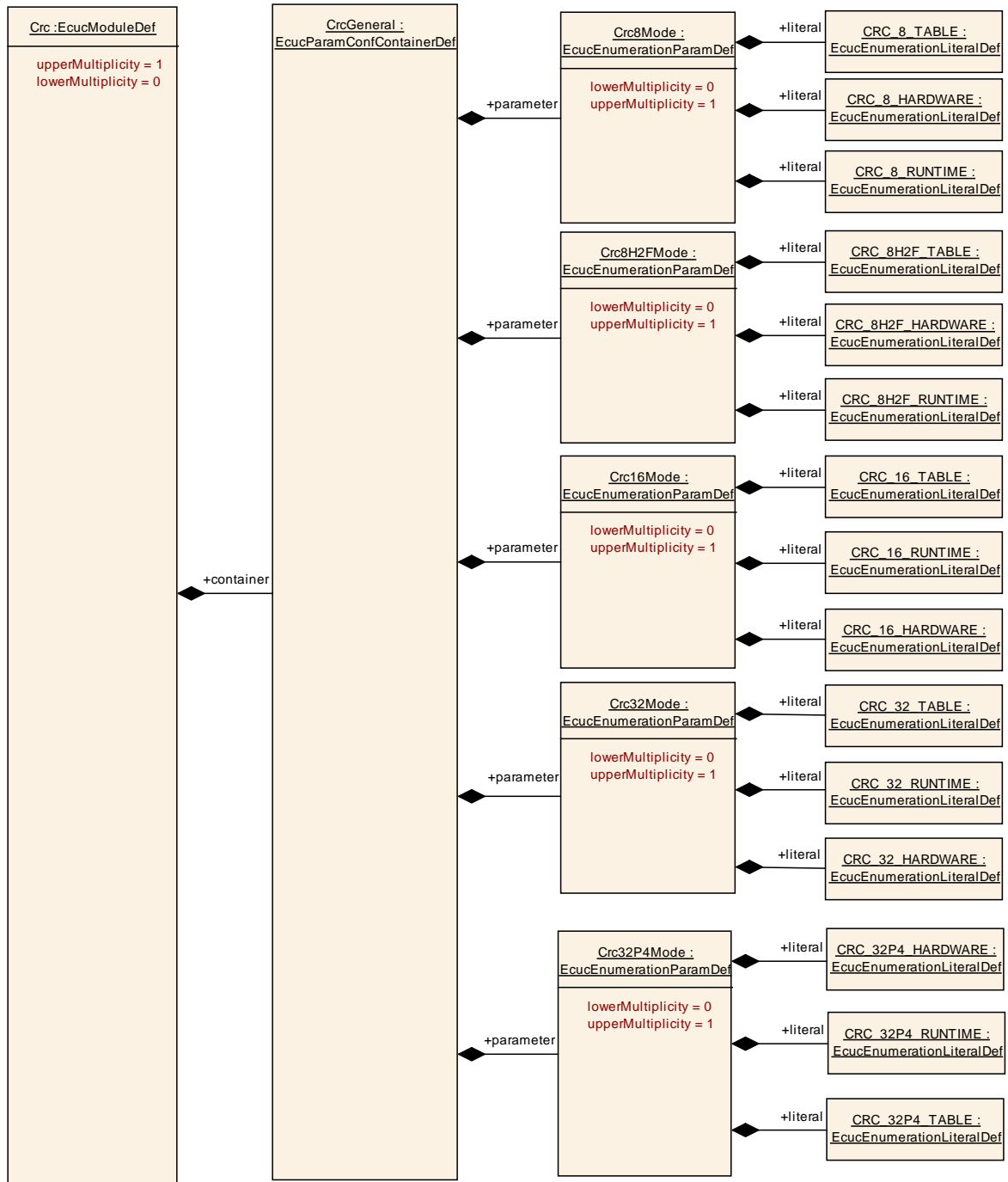

10.2.1 Variants

[SWS_Crc_00040] [VARIANT-PRE-COMPILE: Only parameters with "Pre-compile time" configuration are allowed in this variant.] ()

10.2.2 Crc

Module Name	Crc
Module Description	Configuration of the Crc (Crc routines) module.
Post-Build Variant Support	false

Included Containers		
Container Name	Multiplicity	Scope / Dependency
CrcGeneral	1	General configuration of CRC module

10.2.3 CrcGeneral

SWS Item	ECUC_Crc_00006 :
Container Name	CrcGeneral
Description	General configuration of CRC module
Configuration Parameters	

SWS Item	ECUC_Crc_00025 :	
Name	Crc16Mode	
Description	Switch to select one of the available CRC 16-bit (CCITT) calculation methods	
Multiplicity	0..1	
Type	EcucEnumerationParamDef	
Range	CRC_16_HARDWARE hardware based CRC16 calculation CRC_16_RUNTIME runtime based CRC16 calculation CRC_16_TABLE table based CRC16 calculation (default selection)	
Post-Build Variant Multiplicity	false	
Post-Build Variant Value	false	
Multiplicity Configuration Class	Pre-compile time	X All Variants
	Link time	--
	Post-build time	--
Value Configuration Class	Pre-compile time	X All Variants
	Link time	--
	Post-build time	--
Scope / Dependency	scope: local	

SWS Item	ECUC_Crc_00026 :
Name	Crc32Mode
Description	Switch to select one of the available CRC 32-bit (IEEE-802.3 CRC32 Ethernet Standard) calculation methods
Multiplicity	0..1
Type	EcucEnumerationParamDef
Range	CRC_32_HARDWARE hardware based CRC32 calculation CRC_32_RUNTIME runtime based CRC32 calculation CRC_32_TABLE table based CRC32 calculation (default selection)
Post-Build Variant Multiplicity	false

Post-Build Variant Value	false		
Multiplicity Configuration Class	Pre-compile time	X	All Variants
	Link time	--	
	Post-build time	--	
Value Configuration Class	Pre-compile time	X	All Variants
	Link time	--	
	Post-build time	--	
Scope / Dependency	scope: local		

SWS Item	ECUC_Crc_00032 :		
Name	Crc32P4Mode		
Description	Switch to select one of the available CRC 32-bit E2E Profile 4 calculation methods.		
Multiplicity	0..1		
Type	EcucEnumerationParamDef		
Range	CRC_32P4_HARDWARE	hardware based CRC32P4 calculation	
	CRC_32P4_RUNTIME	runtime based CRC32P4 calculation	
	CRC_32P4_TABLE	table based CRC32P4 calculation (default selection)	
Post-Build Variant Multiplicity	false		
Post-Build Variant Value	false		
Multiplicity Configuration Class	Pre-compile time	X	All Variants
	Link time	--	
	Post-build time	--	
Value Configuration Class	Pre-compile time	X	All Variants
	Link time	--	
	Post-build time	--	
Scope / Dependency	scope: local		

SWS Item	ECUC_Crc_00031 :		
Name	Crc8H2FMode		
Description	Switch to select one of the available CRC 8-bit (2Fh polynomial) calculation methods		
Multiplicity	0..1		
Type	EcucEnumerationParamDef		
Range	CRC_8H2F_HARDWARE	hardware based CRC8H2F calculation	
	CRC_8H2F_RUNTIME	runtime based CRC8H2F calculation	
	CRC_8H2F_TABLE	table based CRC8H2F calculation (default selection)	
Post-Build Variant Multiplicity	false		
Post-Build Variant Value	false		
Multiplicity Configuration Class	Pre-compile time	X	All Variants
	Link time	--	
	Post-build time	--	
Value Configuration Class	Pre-compile time	X	All Variants
	Link time	--	
	Post-build time	--	
Scope / Depend-	scope: local		

ency	
SWS Item	ECUC_Crc_00030 :
Name	Crc8Mode
Description	Switch to select one of the available CRC 8-bit (SAE J1850) calculation methods
Multiplicity	0..1
Type	EcucEnumerationParamDef
Range	CRC_8_HARDWARE hardware based CRC8 calculation
	CRC_8_RUNTIME runtime based CRC8 calculation
	CRC_8_TABLE table based CRC8 calculation (default selection)
Post-Build Variant Multiplicity	false
Post-Build Variant Value	false
Multiplicity Configuration Class	Pre-compile time X All Variants
	Link time --
	Post-build time --
Value Configuration Class	Pre-compile time X All Variants
	Link time --
	Post-build time --
Scope / Dependency	scope: local
No Included Containers	

10.3 Published Information

[SWS_Crc_00050] [The standardized common published parameters as required by SRS_BSW_00402 in the SRS General on Basic Software Modules [3] shall be published within the header file of this module and need to be provided in the BSW ModuleDescription. The according module abbreviation can be found in the List of Basic Software Modules [1].] ()

Additional module-specific published parameters are listed below if applicable.

SWS Item		[SWS_Crc_00048]
Information elements		
Information element name	Type / Range	Information element description
Crc_VENDOR_ID	#define/ uint16	Vendor ID of the dedicated implementation of this module according to the AUTOSAR vendor list
Crc_MODULE_ID	#define/ uint8	Module ID of this module from Module List
Crc_AR_RELEASE_MAJOR_VERSION	#define/ uint8	Major version number of AUTOSAR release on which the appropriate implementation is based on.
Crc_AR_RELEASE_MINOR_VERSION	#define/ uint8	Minor version number of AUTOSAR release on which the appropriate implementation is based on.
Crc_AR_RELEASE_REVISION_VERSION	#define/ uint8	Patch level version number of AUTOSAR release on which the appropriate implementation is based on.
Crc_SW_MAJOR_VERSION	#define/ uint8	Major version number of the vendor specific implementation of the module. The numbering is vendor specific.
Crc_SW_MINOR_VERSION	#define/ uint8	Minor version number of the vendor specific implementation of the module. The numbering is vendor specific.
Crc_SW_PATCH_VERSION	#define/ uint8	Patch level version number of the vendor specific implementation of the module. The numbering is vendor specific.

11 Not applicable requirements

[SWS_Crc_00051] [These requirements are not applicable to this specification.]

(SRS_BSW_00344, SRS_BSW_00404, SRS_BSW_00405, SRS_BSW_00170, SRS_BSW_00412, SRS_BSW_00383, SRS_BSW_00384, SRS_BSW_00387, SRS_BSW_00388, SRS_BSW_00389, SRS_BSW_00395, SRS_BSW_00398, SRS_BSW_00399, SRS_BSW_00400, SRS_BSW_00401, SRS_BSW_00375, SRS_BSW_00101, SRS_BSW_00416, SRS_BSW_00406, SRS_BSW_00168, SRS_BSW_00423, SRS_BSW_00424, SRS_BSW_00425, SRS_BSW_00427, SRS_BSW_00428, SRS_BSW_00429, BSW00431, SRS_BSW_00432, SRS_BSW_00433, BSW00434, SRS_BSW_00336, SRS_BSW_00337, SRS_BSW_00338, SRS_BSW_00369, SRS_BSW_00339, BSW00421, SRS_BSW_00422, BSW00420, SRS_BSW_00417, SRS_BSW_00323, SRS_BSW_00409, SRS_BSW_00385, SRS_BSW_00386, SRS_BSW_00161, SRS_BSW_00162, BSW324, SRS_BSW_00005, SRS_BSW_00415, SRS_BSW_00164, SRS_BSW_00325, SRS_BSW_00326, SRS_BSW_00342, SRS_BSW_00343, SRS_BSW_00160, SRS_BSW_00007, SRS_BSW_00347, SRS_BSW_00305, SRS_BSW_00307, SRS_BSW_00373, SRS_BSW_00327, SRS_BSW_00335, SRS_BSW_00350, SRS_BSW_00410, SRS_BSW_00314, SRS_BSW_00370, SRS_BSW_00348, SRS_BSW_00353, SRS_BSW_00361, SRS_BSW_00302, SRS_BSW_00328, SRS_BSW_00312, SRS_BSW_00006, SRS_BSW_00304, SRS_BSW_00355, SRS_BSW_00378, SRS_BSW_00306, SRS_BSW_00308, SRS_BSW_00309, SRS_BSW_00371, SRS_BSW_00358, SRS_BSW_00414, SRS_BSW_00376, SRS_BSW_00359, SRS_BSW_00360, SRS_BSW_00330, SRS_BSW_00331, SRS_BSW_00009, SRS_BSW_00172, SRS_BSW_00010, SRS_BSW_00333, SRS_BSW_00321, SRS_BSW_00341, SRS_BSW_00334)