

<b>Document Title</b>	Methodology
<b>Document Owner</b>	AUTOSAR
<b>Document Responsibility</b>	AUTOSAR
<b>Document Identification No</b>	068
<b>Document Classification</b>	Auxiliary

<b>Document Version</b>	3.2.0
<b>Document Status</b>	Final
<b>Part of Release</b>	4.1
<b>Revision</b>	3

<b>Document Change History</b>			
<b>Date</b>	<b>Version</b>	<b>Changed by</b>	<b>Description</b>
31.03.2014	3.2.0	AUTOSAR Release Management	<ul style="list-style-type: none"> <li>• Alignment of the AUTOSAR Methodology to the System Description categories</li> <li>• Editorial changes</li> </ul>
29.10.2013	3.1.0	AUTOSAR Release Management	<ul style="list-style-type: none"> <li>• Harmonization between ECU Configuration specification and AUTOSAR Methodology</li> </ul>
29.01.2013	3.0.0	AUTOSAR Administration	<ul style="list-style-type: none"> <li>• Allow the usage of requirement ID definition and tracing for specification items</li> <li>• Updated chapter 3.6 Ecu Integration and Configuration with support for A2L function</li> <li>• Added chapter 2.14 How to resolve Name Conflicts</li> <li>• Added sections 3.4.1.15 Define Consistency Needs and 3.4.2.17 Consistency Needs</li> <li>• Refine definition of Binding Times</li> </ul>

01.11.2011	2.1.0	AUTOSAR Administration	<ul style="list-style-type: none"> <li>• Simplification of use case diagrams by removing task use and introducing deliverables on use cases level (see Methodology Concept chapter)</li> <li>• Readability improvement by generation of tables with navigable links</li> <li>• Introduction of Variant Handling, E2E support, System Constraints Description</li> <li>• Refinement of Methodology Library, including the extension of deliverables in different use cases</li> </ul>
01.11.2010	2.0.0	AUTOSAR Administration	<ul style="list-style-type: none"> <li>• Changed tool platform for the SPEM model</li> <li>• Publish as pdf file instead of html</li> <li>• Used new table format for the model elements</li> <li>• Added SPEM diagrams</li> <li>• Methodology Concept chapter detailed</li> <li>• Memory Mapping use case added</li> <li>• Reworked and restructured use cases for more readability</li> <li>• Direct references to meta-model elements in figures and tables</li> </ul>
23.06.2008	1.2.1	AUTOSAR Administration	<ul style="list-style-type: none"> <li>• Legal Disclaimer revised</li> </ul>
28.11.2007	1.2.0	AUTOSAR Administration	<ul style="list-style-type: none"> <li>• Subchapter limitations of the current version enhanced</li> <li>• Document meta information extended</li> <li>• Small layout adaptations made</li> </ul>

31.01.2007	1.1.0	AUTOSAR Administration	<ul style="list-style-type: none"><li>• Updated chapter 5 "ECU-Design</li><li>• Updated chapter 6.1 Relationship with Services</li><li>• Legal disclaimer revised</li><li>• Release Notes added</li><li>• Advice for users revised</li><li>• Revision Information added</li></ul>
27.04.2006	1.0.0	AUTOSAR Administration	<ul style="list-style-type: none"><li>• Initial release</li></ul>

## **Disclaimer**

This specification and the material contained in it, as released by AUTOSAR, is for the purpose of information only. AUTOSAR and the companies that have contributed to it shall not be liable for any use of the specification.

The material contained in this specification is protected by copyright and other types of Intellectual Property Rights. The commercial exploitation of the material contained in this specification requires a license to such Intellectual Property Rights.

This specification may be utilized or reproduced without any modification, in any form or by any means, for informational purposes only.

For any other purpose, no part of the specification may be utilized or reproduced, in any form or by any means, without permission in writing from the publisher.

The AUTOSAR specifications have been developed for automotive applications only. They have neither been developed, nor tested for non-automotive applications.

The word AUTOSAR and the AUTOSAR logo are registered trademarks.

## **Advice for users**

AUTOSAR specifications may contain exemplary items (exemplary reference models, "use cases", and/or references to exemplary technical solutions, devices, processes or software).

Any such exemplary items are contained in the specifications for illustration purposes only, and they themselves are not part of the AUTOSAR Standard. Neither their presence in such specifications, nor any later documentation of AUTOSAR conformance of products actually implementing such exemplary items, imply that intellectual property rights covering such exemplary items are licensed under the same rules as applicable to the AUTOSAR Standard.

## Table of Contents

1	Introduction	16
1.1	Objective	16
1.2	Overview	16
1.3	Known Limitations	16
1.4	Scope	17
1.5	Methodology Concepts	17
1.5.1	Method Library (Method Content)	18
1.5.1.1	Task Definition	19
1.5.1.2	Work Product Definition	20
1.5.1.3	Role Definition	22
1.5.1.4	Tool Definition	23
1.5.1.5	Guidance	23
1.5.1.6	Tables	24
1.5.2	Capability Patterns (Use Case Elements)	27
1.5.2.1	Activity	28
1.6	Requirements Traceability	31
2	Use Cases	40
2.1	Overall View	40
2.1.1	Purpose	40
2.1.2	Description	40
2.1.2.1	Views on the System	40
2.1.2.2	Overall Workflow	40
2.1.3	Workflow	42
2.2	Develop an Abstract System Description	44
2.2.1	Purpose	44
2.2.2	Description	44
2.2.3	Workflow	46
2.3	Develop a VFB System Description	47
2.3.1	Purpose	47
2.3.2	Description	47
2.3.3	Workflow	49
2.4	Develop Software Components	52
2.4.1	Develop an Atomic Software Component	52
2.4.1.1	Purpose	52
2.4.1.2	Description	52
2.4.1.3	Workflow	52
2.4.2	Develop Application Software	57
2.4.2.1	Purpose	57
2.4.2.2	Description	57
2.4.2.3	Workflow	57
2.4.3	Uses Cases for more Specialized Software Components	58
2.4.3.1	Purpose	58
2.4.3.2	Description	58

2.4.3.3	Workflow	58
2.5	Develop System and Subsystems	62
2.5.1	Overview	62
2.5.1.1	Purpose	62
2.5.1.2	Description	62
2.5.2	Design System	66
2.5.2.1	Purpose	66
2.5.2.2	Description	66
2.5.2.3	Workflow	67
2.5.3	Generate System Extract	71
2.5.3.1	Purpose	71
2.5.3.2	Description	72
2.5.3.3	Workflow	72
2.5.4	Create ECU System Description	72
2.5.4.1	Purpose	72
2.5.4.2	Description	72
2.5.4.3	Workflow	73
2.5.5	Design Sub-System	74
2.5.5.1	Purpose	74
2.5.5.2	Description	74
2.5.5.3	Workflow	76
2.5.6	Generate ECU Extract	76
2.5.6.1	Purpose	76
2.5.6.2	Description	77
2.5.6.3	Workflow	77
2.6	Develop Basic Software	78
2.6.1	Overview	78
2.6.1.1	Purpose	78
2.6.1.2	Description	79
2.6.1.3	Workflow	79
2.6.2	Design BSW	80
2.6.2.1	Purpose	80
2.6.2.2	Description	80
2.6.2.3	Workflow	81
2.6.3	Develop BSW Module	82
2.6.3.1	Purpose	82
2.6.3.2	Description	82
2.6.3.3	Workflow	83
2.7	Integrate Software for ECU	85
2.7.1	Description	85
2.7.2	Overview	86
2.7.2.1	Purpose	86
2.7.2.2	Description	86
2.7.2.3	Workflow	89
2.7.3	Prepare ECU Configuration	90
2.7.3.1	Description	90

2.7.3.2	Workflow	91
2.7.4	Configure BSW and RTE	92
2.7.4.1	Description	92
2.7.4.2	Workflow	93
2.7.5	Model ECU Timing	95
2.7.5.1	Workflow	95
2.7.6	Generate BSW and RTE	95
2.7.6.1	Description	95
2.7.6.2	Workflow	96
2.7.7	Build Executable	99
2.7.7.1	Description	99
2.7.7.2	Workflow	101
2.7.8	Configuration Classes	102
2.7.8.1	Configuration Class: Pre-compile Time	103
2.7.8.2	Configuration Class: Link Time	107
2.7.8.3	Configuration Class: Post-build Time Loadable	111
2.7.8.4	Configuration Class: Post-build Time Selectable	114
2.8	Components and Services	117
2.8.1	Purpose	117
2.8.2	Description	117
2.8.3	Workflow	117
2.9	Calibration Overview	123
2.9.1	Purpose	123
2.9.2	Description	123
2.9.3	Workflow	124
2.10	Memory Mapping	128
2.10.1	Purpose	128
2.10.2	Description	129
2.10.3	Workflow	129
2.11	E2E Protection	133
2.11.1	Purpose	133
2.11.2	Description	133
2.11.3	Workflow	134
2.12	Variant Handling	135
2.12.1	Overview	135
2.12.2	Binding Times	136
2.12.2.1	Latest Binding Time	136
2.12.2.2	Actual Binding Time	137
2.12.3	Defining Variants	137
2.12.4	Choosing Variants	138
2.13	Definition of Binding Times	139
2.13.1	Overview	139
2.13.2	A Classification of Artifacts with respect to Binding Times	141
2.13.3	Classification of Binding Times	142
2.13.3.1	BlueprintDerivationTime	143
2.13.3.2	FunctionDesignTime	143

2.13.3.3	InitialBindingTime	144
2.13.3.4	SystemDesignTime	144
2.13.3.5	CodeGenerationTime	144
2.13.3.6	PreCompileTime	145
2.13.3.7	CompileTime	145
2.13.3.8	LinkTime	145
2.13.3.9	PostBuild	145
2.13.3.10	Runtime	146
2.14	How to resolve Name Conflicts	146
2.14.1	Reasons for Name Conflicts	146
2.14.2	Points in the Methodology where Name Conflicts are resolved	147
2.14.3	Mechanisms for resolving Name Conflicts	148
3	Methodology Library	151
3.1	Common Elements	151
3.1.1	Work Product Kinds	151
3.1.2	Tasks	153
3.1.2.1	Add General Documentation	153
3.1.2.2	Define Admin Data	153
3.1.2.3	Define Alias Names	154
3.1.2.4	Evaluate Variant	156
3.1.2.5	Define Memory Addressing Modes	157
3.1.2.6	Configure Memmap Allocation	158
3.1.2.7	Generate BSW Memory Mapping Header	160
3.1.2.8	Generate SWC Memory Mapping Header	163
3.1.2.9	Configure Compiler Memory Classes	165
3.1.2.10	Generate Compiler Configuration	167
3.1.3	Work Products	168
3.1.3.1	General Documentation	168
3.1.3.2	Alias Name Set	169
3.1.3.3	Evaluated Variant Set	169
3.1.3.4	General Autosar Artifact	171
3.1.3.5	General Deliverable	172
3.1.3.6	General Non-Autosar Artifact	172
3.1.3.7	Postbuild Variant Set	173
3.1.3.8	Predefined Variant	174
3.1.3.9	Standard Header Files	175
3.1.3.10	System Constant Value Set	177
3.1.4	Roles	178
3.1.5	Tools	186
3.1.5.1	Compiler	186
3.1.5.2	Linker	187
3.2	Virtual Functional Bus	187
3.2.1	Tasks	188
3.2.1.1	Define VFB Top Level	188
3.2.1.2	Define VFB Composition Component	189



3.2.1.3	Extend Composition . . . . .	190
3.2.1.4	Define VFB Component Constraints . . . . .	192
3.2.1.5	Define VFB Application Software Component . . . . .	193
3.2.1.6	Define VFB Sensor or Actuator Component . . . . .	194
3.2.1.7	Define VFB Parameter Component . . . . .	195
3.2.1.8	Define ECU Abstraction Component . . . . .	196
3.2.1.9	Define Complex Driver Component . . . . .	197
3.2.1.10	Define Wrapper Components to Integrate Legacy Software . . . . .	198
3.2.1.11	Define VFB Interfaces . . . . .	199
3.2.1.12	Define VFB Types . . . . .	200
3.2.1.13	Define VFB Modes . . . . .	201
3.2.1.14	Define VFB Constants . . . . .	202
3.2.1.15	Define VFB Timing . . . . .	203
3.2.1.16	Define VFB Variants . . . . .	204
3.2.1.17	Define E2E Protection Set for Software Components . . . . .	206
3.2.2	Work Products . . . . .	207
3.2.2.1	VFB System . . . . .	207
3.2.2.2	Overall VFB System . . . . .	210
3.2.2.3	VFB System Extract . . . . .	211
3.2.2.4	VFB Top Level System Composition . . . . .	212
3.2.2.5	VFB Composition Component . . . . .	212
3.2.2.6	VFB AUTOSAR Standard Package . . . . .	214
3.2.2.7	AUTOSAR Specification of Application Interfaces . . . . .	216
3.2.2.8	VFB Atomic Software Component . . . . .	217
3.2.2.9	VFB Atomic Application Software Component . . . . .	219
3.2.2.10	Complex Driver Component . . . . .	219
3.2.2.11	ECU Abstraction Software Component . . . . .	220
3.2.2.12	VFB Parameter Component . . . . .	221
3.2.2.13	VFB Sensor Actuator Component . . . . .	222
3.2.2.14	VFB Non AUTOSAR Component . . . . .	222
3.2.2.15	VFB Interfaces . . . . .	223
3.2.2.16	VFB Types . . . . .	224
3.2.2.17	VFB Data Type Mapping Set . . . . .	227
3.2.2.18	VFB Modes . . . . .	227
3.2.2.19	VFB Constants . . . . .	229
3.2.2.20	VFB Software Component Mapping Constraints . . . . .	229
3.2.2.21	VFB Timing . . . . .	230
3.2.2.22	E2E Protection Set . . . . .	230
3.3	System . . . . .	231
3.3.1	Tasks . . . . .	231
3.3.1.1	Set System Root . . . . .	231
3.3.1.2	Assign Top Level Composition . . . . .	232
3.3.1.3	Define ECU Description . . . . .	233
3.3.1.4	Define System Topology . . . . .	234
3.3.1.5	Define Software Component Mapping Constraints . . . . .	234

3.3.1.6	Deploy Software Component	236
3.3.1.7	Generate or Adjust System Flat Map	237
3.3.1.8	Derive Communication Needs	238
3.3.1.9	Define Signal Path Constraints	239
3.3.1.10	Define System Variants	240
3.3.1.11	Define System Timing	242
3.3.1.12	Extend Topology	243
3.3.1.13	Select Software Component Implementation	244
3.3.1.14	Select Design Time Variant	245
3.3.1.15	Define System View Mapping	246
3.3.2	Work Products	247
3.3.2.1	System Description	247
3.3.2.2	Abstract System Description	251
3.3.2.3	Complete ECU Description	253
3.3.2.4	System Description Root Element	253
3.3.2.5	System Mapping Overview	254
3.3.2.6	Software Component Mapping Constraints	256
3.3.2.7	Data Mapping	257
3.3.2.8	Mapping of Software Components to ECUs	257
3.3.2.9	Mapping of Software Components to Implementations	258
3.3.2.10	Signal Path Constraints	259
3.3.2.11	Topology	259
3.3.2.12	Ecu Resources Description	260
3.3.2.13	System Signal	261
3.3.2.14	System Signal Group	262
3.3.2.15	System Flat Map	263
3.3.2.16	System Timing	264
3.3.2.17	System View Mapping	265
3.3.3	Communication Matrix and Communication Layers	266
3.3.3.1	Tasks	266
3.3.3.2	Work Products	273
3.3.4	ECU Extract	277
3.3.4.1	Tasks	277
3.3.4.2	Work Products	284
3.4	Software Component	292
3.4.1	Tasks	292
3.4.1.1	Define Software Component Internal Behavior	292
3.4.1.2	Define Partial Flat Map	293
3.4.1.3	Define Software Component Timing	294
3.4.1.4	Define SymbolProps for Types	295
3.4.1.5	Add Documentation to the Software Component	297
3.4.1.6	Generate Atomic Software Component Contract Header Files	298
3.4.1.7	Generate Component Header File in Vendor Mode	300
3.4.1.8	Generate Component Prebuild Data Set	302
3.4.1.9	Implement Atomic Software Component	304

3.4.1.10	Generate E2E Protection Wrapper . . . . .	305
3.4.1.11	Compile Atomic Software Component . . . . .	307
3.4.1.12	Map Software Component to BSW . . . . .	308
3.4.1.13	Measure Component Resources . . . . .	310
3.4.1.14	Recompile Component in ECU Context . . . . .	311
3.4.1.15	Define Consistency Needs . . . . .	312
3.4.2	Work Products . . . . .	314
3.4.2.1	Delivered Atomic Software Components . . . . .	314
3.4.2.2	Software Component Internal Behavior . . . . .	317
3.4.2.3	Atomic Software Component Implementation . . . . .	318
3.4.2.4	Software Component Documentation . . . . .	320
3.4.2.5	Software Component Timing . . . . .	321
3.4.2.6	Software Component to BSW Mapping . . . . .	321
3.4.2.7	Partial Flat Map . . . . .	322
3.4.2.8	Application Header File . . . . .	324
3.4.2.9	Software Component Data Types Header . . . . .	324
3.4.2.10	Component RTE Prebuild Configuration Header . . . . .	325
3.4.2.11	E2E Protection Wrapper Header File . . . . .	325
3.4.2.12	E2E Protection Wrapper Source Code . . . . .	326
3.4.2.13	Atomic Software Component Source Code . . . . .	327
3.4.2.14	Atomic Software Component Object Code . . . . .	327
3.4.2.15	Optimized Application Header File . . . . .	328
3.4.2.16	Optimized Software Component Object Code . . . . .	328
3.4.2.17	Consistency Needs . . . . .	328
3.4.3	Tools . . . . .	329
3.4.3.1	Component API Generator Tool . . . . .	329
3.5	Basic Software . . . . .	330
3.5.1	Tasks . . . . .	331
3.5.1.1	Define BSW Types . . . . .	331
3.5.1.2	Define BSW Entries . . . . .	332
3.5.1.3	Define BSW Interfaces . . . . .	333
3.5.1.4	Define Vendor Specific Module Definition . . . . .	334
3.5.1.5	Define BSW Behavior . . . . .	335
3.5.1.6	Define BSW Module Timing . . . . .	336
3.5.1.7	Generate BSW Contract Header Files . . . . .	337
3.5.1.8	Implement a BSW Module . . . . .	338
3.5.1.9	Develop BSW Module Generator . . . . .	340
3.5.1.10	Create Library . . . . .	341
3.5.1.11	Compile BSW Core Code . . . . .	343
3.5.1.12	Generate BSW Module Prebuild Dataset . . . . .	345
3.5.2	Work Products . . . . .	346
3.5.2.1	BSW Standard Package . . . . .	346
3.5.2.2	BSW Module Bundle . . . . .	348
3.5.2.3	BSW Design Bundle . . . . .	349
3.5.2.4	BSW Module ICS Bundle . . . . .	350
3.5.2.5	BSW Module Delivered Bundle . . . . .	351

3.5.2.6	AUTOSAR Software Module Specification . . . . .	353
3.5.2.7	AUTOSAR Standard Types . . . . .	354
3.5.2.8	AUTOSAR Platform Types . . . . .	354
3.5.2.9	BSW Module Generator . . . . .	355
3.5.2.10	AUTOSAR Standardized ECU Configuration Parameter Definition . . . . .	355
3.5.2.11	BSW Module Preconfigured Configuration . . . . .	356
3.5.2.12	BSW Module Recommended Configuration . . . . .	357
3.5.2.13	BSW Module Vendor Specific Configuration Parameter Definition . . . . .	358
3.5.2.14	BSW Types . . . . .	359
3.5.2.15	Basic Software Entries . . . . .	359
3.5.2.16	Basic Software Module Description . . . . .	359
3.5.2.17	Basic Software Module Internal Behavior . . . . .	360
3.5.2.18	Basic Software Module Implementation Description . . . . .	361
3.5.2.19	Build Action Manifest . . . . .	362
3.5.2.20	Basic Software Module Timing . . . . .	363
3.5.2.21	Basic Software Module Core Header . . . . .	364
3.5.2.22	Basic Software Module Core Source Code . . . . .	364
3.5.2.23	Basic Software Interlink Header . . . . .	365
3.5.2.24	Basic Software Interlink Types Header . . . . .	366
3.5.2.25	BSW RTE Prebuild Configuration Header . . . . .	366
3.5.2.26	Basic Software Module Object Code . . . . .	367
3.5.2.27	Library Description . . . . .	367
3.5.2.28	Library Header Files . . . . .	368
3.5.2.29	Library Object Code . . . . .	369
3.6	ECU Integration and Configuration . . . . .	369
3.6.1	Tasks . . . . .	369
3.6.1.1	Provide RTE Calibration Dataset . . . . .	369
3.6.1.2	Define Integration Variant . . . . .	370
3.6.1.3	Generate Base ECU Configuration . . . . .	372
3.6.1.4	Define ECU Timing . . . . .	373
3.6.1.5	Configure EcuC . . . . .	374
3.6.1.6	Configure OS . . . . .	376
3.6.1.7	Configure RTE . . . . .	378
3.6.1.8	Configure Watchdog Manager . . . . .	380
3.6.1.9	Configure Mode Management . . . . .	381
3.6.1.10	Configure NvM . . . . .	382
3.6.1.11	Configure Diagnostics . . . . .	384
3.6.1.12	Create Service Component . . . . .	385
3.6.1.13	Connect Service Component . . . . .	389
3.6.1.14	Configure COM . . . . .	390
3.6.1.15	Configure IO Hardware Abstraction . . . . .	392
3.6.1.16	Configure MCAL . . . . .	393
3.6.1.17	Configure Debug . . . . .	394

3.6.1.18	Generate BSW Configuration Code and Model Extensions	397
3.6.1.19	Generate Local MC Data Support	399
3.6.1.20	Create MC Function Model	400
3.6.1.21	Generate RTE	402
3.6.1.22	Generate Scheduler	405
3.6.1.23	Generate OS	406
3.6.1.24	Generate RTE Prebuild Dataset	407
3.6.1.25	Compile ECU Source Code	408
3.6.1.26	Generate ECU Executable	410
3.6.1.27	Generate RTE Postbuild Dataset	412
3.6.1.28	Generate A2L	413
3.6.1.29	Measure Resources	415
3.6.2	Work Products	416
3.6.2.1	BSW Module Integration Bundle	416
3.6.2.2	ECU Software Delivered	417
3.6.2.3	Service Component Description	418
3.6.2.4	ECU Service Connectors	419
3.6.2.5	ECU Timing	419
3.6.2.6	BSW Module Interface Extension	420
3.6.2.7	BSW Module Behavior Extension	420
3.6.2.8	BSW Module Implementation Extension	421
3.6.2.9	ECU Configuration Values	421
3.6.2.10	RTE Implementation Description	424
3.6.2.11	RTE Prebuild Configuration Header	425
3.6.2.12	Calibration Parameter Value Set	425
3.6.2.13	MC Function Model	426
3.6.2.14	Local Measurement and Calibration Support Data	427
3.6.2.15	RTE Measurement and Calibration Support Data	428
3.6.2.16	RTE Source Code	430
3.6.2.17	BSW Scheduler Code	430
3.6.2.18	OS Generated Code	431
3.6.2.19	RTE Postbuild Variants Dataset	431
3.6.2.20	ECU Object Code	431
3.6.2.21	ECU Executable	432
3.6.2.22	Map of the ECU Executable	433
3.6.2.23	A2L File	433
3.6.2.24	MC Driver Support Data	433
3.6.2.25	MC Additional Config	434
3.6.3	Tools	434
3.6.3.1	RTE Generator	434
3.6.3.2	BSW Generator Framework	435
3.6.4	ECU Config Classes	435
3.6.4.1	Tasks	435
3.6.4.2	Work Products	447
A	History of Constraints and Specification Items	451

- A.1 Constraint History of this Document according to AUTOSAR R4.1.1 . . . 451
  - A.1.1 Added Specification Items in R4.1.1 . . . . . 451
- A.2 Constraint History of this Document according to AUTOSAR R4.1.2 . . . 454
  - A.2.1 Added Specification Items in R4.1.2 . . . . . 454
- A.3 Constraint History of this Document according to AUTOSAR R4.1.3 . . . 454
  - A.3.1 Added Specification Items in R4.1.3 . . . . . 454
  - A.3.2 Changed Specification Items in R4.1.3 . . . . . 454

## References

- [1] Requirements on Methodology  
AUTOSAR\_RS\_Methodology
- [2] Software Process Engineering Meta-Model Specification  
<http://www.omg.org/spec/SPEM/2.0/>
- [3] Virtual Functional Bus  
AUTOSAR\_EXP\_VFB
- [4] Software Component Template  
AUTOSAR\_TPS\_SoftwareComponentTemplate
- [5] Basic Software Module Description Template  
AUTOSAR\_TPS\_BSWModuleDescriptionTemplate
- [6] System Template  
AUTOSAR\_TPS\_SystemTemplate
- [7] Specification of ECU Configuration  
AUTOSAR\_TPS\_ECUConfiguration
- [8] Specification of Memory Mapping  
AUTOSAR\_SWS\_MemoryMapping
- [9] Specification of Compiler Abstraction  
AUTOSAR\_SWS\_CompilerAbstraction
- [10] Specification of SW-C End-to-End Communication Protection Library  
AUTOSAR\_SWS\_E2ELibrary
- [11] Generic Structure Template  
AUTOSAR\_TPS\_GenericStructureTemplate
- [12] Standardization Template  
AUTOSAR\_TPS\_StandardizationTemplate
- [13] General Specification of Basic Software Modules  
AUTOSAR\_SWS\_BSWGeneral
- [14] Specification of ECU Resource Template  
AUTOSAR\_TPS\_ECUResourceTemplate

# 1 Introduction

## 1.1 Objective

AUTOSAR requires a common technical approach for some steps of system development. This approach is called the AUTOSAR methodology. This document defines and describes this AUTOSAR methodology. It covers all major steps of the development of a system with AUTOSAR: from the definition of the Virtual Functional Bus to the generation of an ECU executable.

The requirements for the methodology are defined in the document [1].

## 1.2 Overview

**[TR\_METH\_01000] Domains of the AUTOSAR methodology** [ The AUTOSAR methodology is structured into several domains of development:

- Virtual Functional Bus
- System
- Software Component
- Basic Software
- ECU

]([RS\\_METH\\_00018](#), [RS\\_METH\\_00032](#))

**[TR\_METH\_01001] AUTOSAR methodology assets** [ For each domain, relevant Work Product, Task, Role, and Tool elements are defined (see chapter 3). In addition, there are elements that are common for all domains (see 3.1). ]([RS\\_METH\\_00025](#), [RS\\_METH\\_00028](#), [RS\\_METH\\_00009](#))

**[TR\_METH\_01002] AUTOSAR methodology use cases** [ Use cases (see chapter 2) show how these standard reusable elements are applied to support real-world development. The Overall View (see chapter 2.1) provides an end to end view on the typical use cases of all domains. ]([RS\\_METH\\_00018](#), [RS\\_METH\\_00056](#), [RS\\_METH\\_00009](#))

## 1.3 Known Limitations

Work products and tasks for End to End communication safety are not completely described in the methodology.



## 1.4 Scope

**[TR\_METH\_01003] Scope of the AUTOSAR methodology** [ The AUTOSAR methodology is not a complete process description, but rather aggregates the various elements of AUTOSAR and shows how they are brought together to develop a complete system. Sample aggregations are provided as Use Cases in Chapter 2. ] ([RS\\_METH\\_00006](#))

**[TR\_METH\_01004] Support for various stakeholders by the AUTOSAR methodology** [ The structure of the methodology was designed to help cover the needs of various AUTOSAR stakeholders:

- Organizations: Methodology is modeled in a modular format to allow organizations to tailor it and combine the Methodology within their own internal processes, while identifying points where they interact with other organizations.
- Engineers: Methodology is scoped to allow engineers of various roles quickly find AUTOSAR information that is relevant to their specific needs.
- Tool Vendors: Methodology provides a common language to share among all AUTOSAR members and a common expectation of what capabilities tools should support.

] ([RS\\_METH\\_00018](#), [RS\\_METH\\_00056](#), [RS\\_METH\\_00009](#))

**[TR\_METH\_01005] Restrictions of AUTOSAR methodology** [ Furthermore, the methodology does not prescribe a precise order in which activities should be carried out. The methodology is a mere work-product flow: it defines the dependencies of activities on work-products. This means that when the information specified in the methodology is available, an activity can be carried out to produce the output work-products. The set of activities is described in Chapter 3.

This restriction implies that the AUTOSAR methodology does not define an overall timeline and does not define how and when iterations are carried out. For example during system and design, the same activity (namely configuring the system) will be carried out repeatedly with various levels of precision. There will be a first "rough" configuration and a final "precise" configuration which might depend on the feedback from the actual configuration or even implementation of ECUs. How and when such refinement steps are to be carried out is NOT defined in the methodology. ] ([RS\\_METH\\_00047](#))

## 1.5 Methodology Concepts

**[TR\_METH\_01006] General AUTOSAR methodology concepts** [ The AUTOSAR methodology defines activities performed by roles that create work products as general reusable method patterns<sup>1</sup>. The reusable method pattern elements are described in the method library section (cf. Section 1.5.1). The methodology also describes

---

<sup>1</sup>The RS\_Methodology document uses the term "Activity" when addressing process elements in general. In the SPEM model the atomic process elements are called "Tasks", whereas an "Activity" is used to organize tasks and to define processes.

sample process patterns of typical use cases considered for the creation of AUTOSAR work products. The patterns use process elements that are described in the use case section (cf. Section 1.5.2).

The definitions and the figures are made according to the Software Process Engineering Meta-Model Specification [2]. The symbols are taken from the Enterprise Architect modeling tool. [\]\(RS\\_METH\\_00018, RS\\_METH\\_00021, RS\\_METH\\_00047, RS\\_METH\\_00048, RS\\_METH\\_00025, RS\\_METH\\_00061, RS\\_METH\\_00028, RS\\_METH\\_00056\)](#)

### 1.5.1 Method Library (Method Content)

**[TR\_METH\_01007] Method Library** [ The Method Library defines the Method Library Elements of every *method pattern* such as Roles, Tasks, and Work Product Definitions. [\]\(RS\\_METH\\_00018, RS\\_METH\\_00021, RS\\_METH\\_00025, RS\\_METH\\_00028\)](#)

**[TR\_METH\_01008] Method Library Element** [ A Method Library Element contains a description of the element to define its purpose in the methodology and thus provides the basic contents of the AUTOSAR methodology. The Method Library Elements are used for the description of the related development processes. These Method Library Elements can be seen as a standard. [\]\(RS\\_METH\\_00017, RS\\_METH\\_00043, RS\\_METH\\_00050, RS\\_METH\\_00064\)](#)

**[TR\_METH\_01009] Relation of Method Library and Method Library Element to the SPEM meta model** [ The Method Library and the Method Library Elements correspond to the Method Content and Method Content Elements in the SPEM meta model [2]. [\]\(RS\\_METH\\_00009\)](#)

**[TR\_METH\_01010] Overview of Method Library Elements** [Method Library Elements comprise:

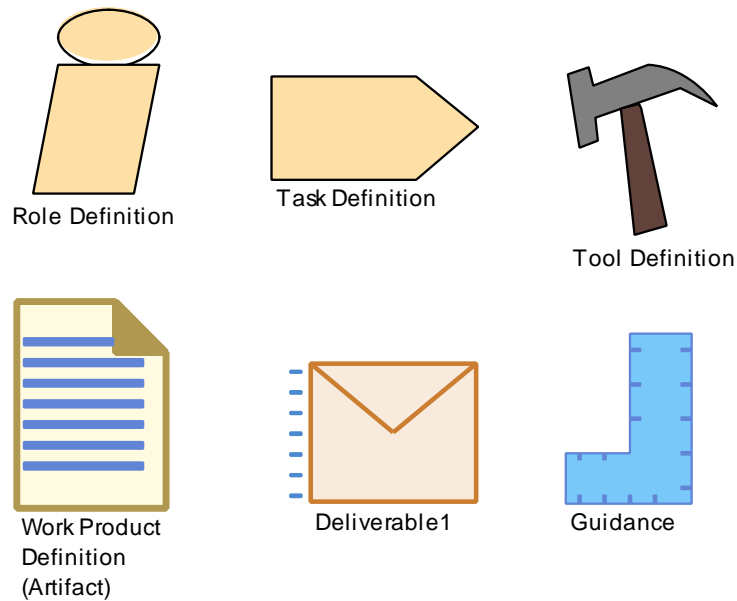
- [Task Definition](#)
- [Work Product Definition](#)
- [Role Definition](#)
- [Tool Definition](#)
- [Guidance<sup>2</sup>](#)

[\]\(RS\\_METH\\_00021, RS\\_METH\\_00025, RS\\_METH\\_00027, RS\\_METH\\_00042, RS\\_METH\\_00028\)](#)

The element symbols are shown in Figure 1.1.

---

<sup>2</sup>The Guidance is currently not used in the AUTOSAR Methodology. It may be used in future documents.



**Figure 1.1: Symbols of AUTOSAR Method Content Elements**

### 1.5.1.1 Task Definition

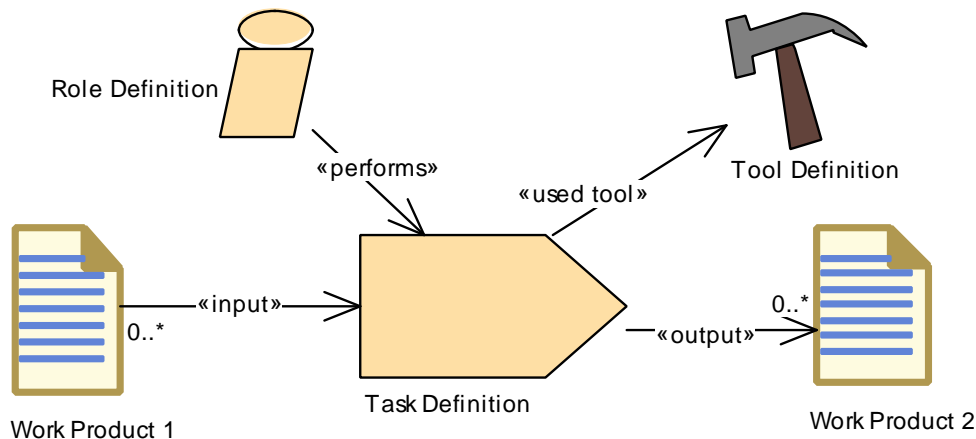
**[TR\_METH\_01011] Task Definition** [ According to the SPEM meta model, a `Task Definition` is an assignable unit of work that is being performed by specific `Roles`. The duration of a task is generally a few hours to a few days. Tasks usually generate one or more work products. Each `Task` is associated to input and output `Work Products`. Inputs are differentiated in *mandatory* and *optional* inputs. A `Task` is used as one element among others to define a `Process`. ]([RS\\_METH\\_00021](#))

**[TR\_METH\_01012] Task semantics** [ A `Task` has a clear purpose in which the performing roles achieve a well defined goal. It provides complete step-by-step explanations of doing all the work that needs to be done to achieve this goal. This description is completely independent of when in a process lifecycle the work would actually be done. It does not describe when what work is being done, but describes all the work that gets done. ]([RS\\_METH\\_00021](#), [RS\\_METH\\_00056](#))

**[TR\_METH\_01013] Task usage** [ When a `Task` is used in a process (cf. `Task Use`), it provides the information of which pieces of the `Task` will actually be performed at any particular point in time. This assumes that the `Task` will be performed in the process over and over again, but each time with a slightly different emphasis on different steps or aspects of the task description [2].

For the AUTOSAR Methodology, a `Task` is a reusable element that is used across multiple methodology use cases. A `Task` is associated to at least one performing `Role` and may have several additional performers. `Tasks` use `Tools` to achieve their outputs. Optional performers and optional input and outputs to the task are described by the relationship's multiplicity. ]([RS\\_METH\\_00021](#), [RS\\_METH\\_00042](#))

An overview of the `Task` as it is used in this document is given in Figure 1.2.



**Figure 1.2: Task Definition Overview**

### 1.5.1.2 Work Product Definition

**[TR\_METH\_01014] Work Product Definition** [ According to the SPEM meta model, a `Work Product Definition` is used, modified, and produced by `Tasks` (i.e. a task input and output). `Work Products` are in most cases tangible work products consumed, produced, or modified by `Tasks`. They may serve as a basis for defining reusable assets. A `Work Product` can be related to other work products by a kind of nesting relationship. ]([RS\\_METH\\_00046](#), [RS\\_METH\\_00047](#), [RS\\_METH\\_00025](#), [RS\\_METH\\_00052](#), [RS\\_METH\\_00061](#), [RS\\_METH\\_00054](#))

**[TR\_METH\_01015] Relationship between Roles and Work Products** [ `Roles` use `Work Products` to perform `Tasks` and produce `Work Products` in the course of performing the `Tasks`. `Work Products` are in the responsibility of the associated `Roles`, thereby also defining a set of skills the performing `Role` should have. Even though one `Role` might own a specific type of `Work Product`, other `Roles` can still use the `Work Product` for their work, and update them [2]. ]([RS\\_METH\\_00052](#), [RS\\_METH\\_00061](#))

A `Work Product` can be of type `Artifact` or `Deliverable`:

- **[TR\_METH\_01017] Artifact Definition** [ `Artifact`: A tangible `Work Product` that is consumed, produced, or modified by one or more `Tasks`. `Artifacts` may be composed of other `Artifacts` and may serve as a basis for defining reusable assets [2]. ]([RS\\_METH\\_00052](#), [RS\\_METH\\_00061](#), [RS\\_METH\\_00054](#))

**[TR\_METH\_01018] Kinds of Artifacts** [ For the AUTOSAR Methodology, typical kinds of artifacts are:

- [AUTOSAR XML](#)
- [Source Code](#)

- Object Code
- Executable
- Text

For more details see chapter 3.1.1. [\]\(RS\\_METH\\_00063, RS\\_METH\\_00015, RS\\_METH\\_00057\)](#)

**[TR\_METH\_01019] Properties of Artifacts** [ At a high level, an artifact is represented as a single conceptual file. As a rule of thumb, the AUTOSAR Methodology will distinguish artifacts that have most of the following properties:

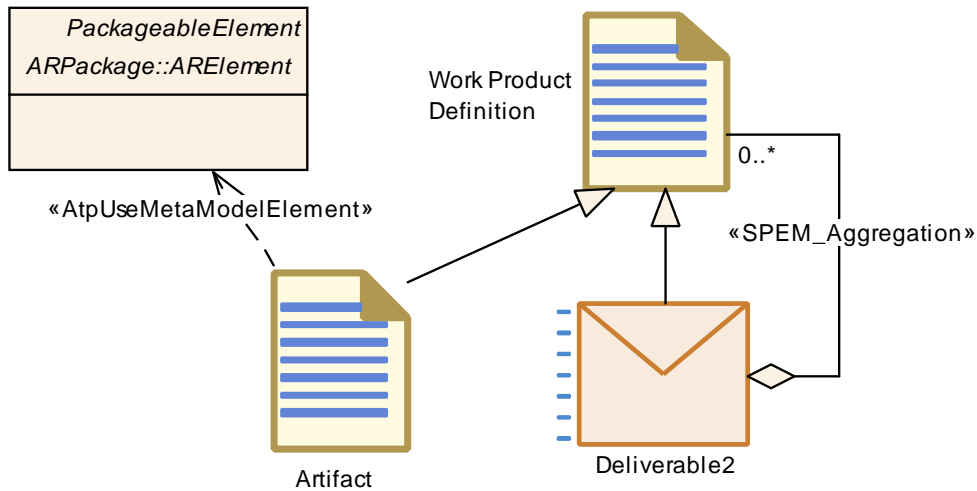
- Separate versioning is needed
- A dedicated life cycle has to be cared for
- Different exchange requirements need to be fulfilled
- Change in responsible roles
- Change in multiplicities
- Change in physical representation or format
- One of the products may be a separate deliverable to another party
- Separation of standardized from non-standardized parts

[\]\(RS\\_METH\\_00063, RS\\_METH\\_00017, RS\\_METH\\_00016\)](#)

**[TR\_METH\_01020] Relationship between Artifacts and meta-model elements** [ To express a relationship between artifacts of the methodology model and any AUTOSAR meta-model element, a relationship with the stereotype «atpUseMetaModelElement» is used to express this "dependency". For AUTOSAR meta-model elements that are not directly related to methodology elements, there is usually an indirect relationship via a related meta-model element. The methodology can thus focus on the main elements of the meta-model. [\]\(RS\\_METH\\_00051\)](#)

- **[TR\_METH\_01021] Deliverable Definition** [ Deliverable: Used to pre-define typical or recommended content in the form of Work Products that would be packaged for delivery. Deliverables are used to represent an output from a process that has value, material or otherwise, to a client, customer, or other stakeholder. [\]\(RS\\_METH\\_00025, RS\\_METH\\_00018, RS\\_METH\\_00054\)](#)

**[TR\_METH\_01022] Aggregation of Work Products** [ A Deliverable is a Work Product that aggregates other Work Products. The Method Content maintains pre-configured potential Deliverables [2]. For the AUTOSAR Methodology, the aggregation relationship is used to indicate which Work Products are contained in a deliverable. [\]\(RS\\_METH\\_00025, RS\\_METH\\_00018, RS\\_METH\\_00054\)](#)



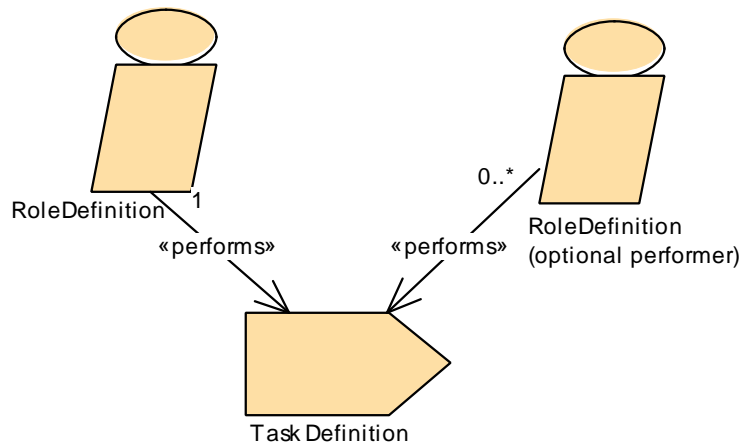
**Figure 1.3: Work Product Definition Overview**

### 1.5.1.3 Role Definition

**[TR\_METH\_01023] Role Definition** [ According to the SPEM meta model, *Role Definitions* define responsibilities of an individual or a set of individuals and thereby define a set of related skills, competencies, and qualifications needed to perform a *Task*. A *Role* can be filled by one person or multiple people, one person may fill several *Roles*. Each *Role* performs *Tasks*. ]([RS\\_METH\\_00028](#))

**[TR\_METH\_01024] Role assignment** [ *Roles* are not individuals or resources. Individual members of the development organization will wear different hats, or perform different *Roles*. The mapping from individual to *Role*, usually performed by the project manager when planning and staffing a project, allows different individuals to act as several different *Roles*, and for a *Role* to be taken by several individuals [2].

In the AUTOSAR Methodology, a *Role* also assigns the responsibility of a *Task* and defines *optional* performers. Performers that are responsible for e.g. a *Task* have a multiplicity of 1 for the relationship to the *Task*, optional performers have optional multiplicity assigned. *Role Definitions* are usually generic and still provide sufficient level of detail for managers to organize a team. Examples of *Roles* are "System Engineer", "Safety Engineer", or "Software Developer". ]([RS\\_METH\\_00028](#), [RS\\_METH\\_00056](#))

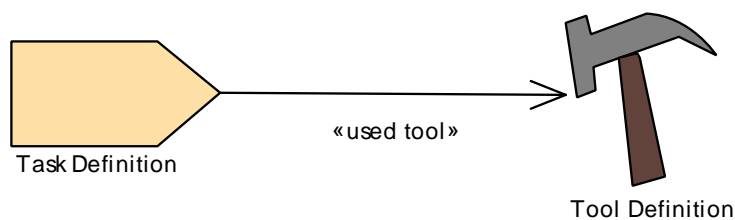


**Figure 1.4: Role Definition Overview**

**1.5.1.4 Tool Definition**

**[TR\_METH\_01025] Tool Definition** [ According to the SPEM meta model, Tool Definitions can be used to specify a tool’s participation in a Task. A Tool Definition describes the capabilities of a CASE tool, general purpose tool, or any other automation unit that supports the associated Roles in performing the work defined by a Task. A Tool can identify a resource as *useful*, *recommended*, or *necessary* for a task’s completion. A Tool can also be used to manage one or more Work Products [2].

The AUTOSAR Methodology uses the Tool Definition to describe AUTOSAR specific (e.g. Software Component Contract Generator) and other general Tools (e.g. Compilers). The relationship of a Tool to a Task shows which Tools a Role will need to perform the Task. ]([RS\\_METH\\_00066](#), [RS\\_METH\\_00042](#))



**Figure 1.5: Tool Definition Overview**

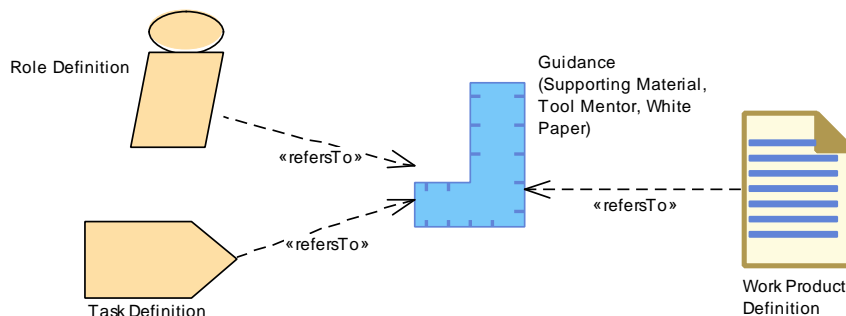
**1.5.1.5 Guidance**

**[TR\_METH\_01026] Guidance definition** [ According to the SPEM meta model, a Guidance provides additional information related to e.g. Roles, Work Products, and Tasks. A Guidance is classified to indicate a specific type for which perhaps a specific structure and type of content is assumed [2]. ]([RS\\_METH\\_00027](#))

**[TR\_METH\_01027] Guidance kinds** [ A Guidance can be a

- **Supporting Material:** Supporting Material is a catch-all for other types of guidance not specifically defined elsewhere. It can be related to all kinds of Content Elements, i.e., including other guidance elements. The AUTOSAR Methodology uses the Supporting Material Guidance type to define title pages, change histories, disclaimers etc.
- **Tool Mentor:** A Tool Mentor shows how to use a specific Tool to accomplish some piece of work either in the context of or independent from a Task or Activity. In the context of the AUTOSAR Methodology, a Tool Mentor is used in the same way as the Tool element.
- **White Paper:** White Papers are concept guidances that have been externally reviewed or published and can be read and understood in isolation from other Method Content. AUTOSAR documents are examples of White Papers.

Other Guidances such as Checklists, Concepts, Estimates, Guidelines, Practices, Reports, Reusable Assets, Roadmaps, or Templates as defined in [2] are not used within the AUTOSAR Methodology. ]([RS\\_METH\\_00027](#))



**Figure 1.6: Guidance Overview**

### 1.5.1.6 Tables

**[TR\_METH\_01028] Usage of tables** [ Beside the graphical visualization of the different SPEM diagrams, tables are used to specify and describe the model elements in detail. ]([RS\\_METH\\_00050](#), [RS\\_METH\\_00064](#))

**[TR\_METH\_01113] Usage of hyperlinks** [ Beside the conventional references to chapters, figures and sections the AUTOSAR methodology document utilizes hyperlinks to the used SPEM elements. These hyperlinks are used across the text and within the tables. Using the hyperlinks the reader can quickly navigate to the related elements such as Tasks, Activities, Roles, Work Products and Tools. ]([RS\\_METH\\_00067](#))

In the Methodology library the following tables are used :



### 1.5.1.6.1 Work Product Kind Tables

<b>Category</b> <i>(Work Product Kind)</i>	<b>Work Product Kind</b>
<b>Package</b>	Location in the MetaModel package
<b>Brief Description</b>	Short Description
<b>Description</b>	Detailed Description

**Table 1.1: Work Product Kind**

### 1.5.1.6.2 Task Definition Tables

<b>Task Definition</b>	<b>Task</b>		
<b>Package</b>	Location in the MetaModel package		
<b>Brief Description</b>	Short description		
<b>Description</b>	Detailed description		
<b>Relation Type</b>	<b>Related Element</b>	<b>Mul.</b>	<b>Note</b>
Performed by	Which Roles Perform the Task	Opt or not	Description of the specific role needed
Consumes	What is Consumed by the Task	Mult	Explanation on why this Element is needed.
Produces	What is produced by the Task	Mult	Explanation on why this Element is needed.
In/out	What is produced and consumed by the Task	Mult	Explanation on why this Element is needed.
Used tool	Tool used for that Task	Mult	

**Table 1.2: Task**

### 1.5.1.6.3 Work Product Definition Tables

<b>Artifact</b>	<b>Work Product</b>		
<b>Package</b>	Location in the MetaModel package		
<b>Brief Description</b>	Short Description.		
<b>Description</b>	Detailed Description		
<b>Kind</b>	Work Product Kind		
<b>Extended by</b>	Artifacts which extend this Artifact		
<b>Extends</b>	Artifacts which are extended by this Artifact		
<b>Relation Type</b>	<b>Related Element</b>	<b>Mul.</b>	<b>Note</b>
Aggregated by	To which Deliverable is it aggregated By	Mult	Description of the context of the Aggregation.

<i>Relation Type</i>	<i>Related Element</i>	<i>Mul.</i>	<i>Note</i>
In/out	Which task is producing and consuming the Work Product	Mult	Description of the context of the Work Product production and consumption.
Produced by	Which task is producing the Work Product	Mult	Description of the context of the Work Product production.
Consumed by	Which task is consuming the Work Product	Mult	Description of the context of the Work Product consumption.
Use meta model element	MetamodelElement Relationship	Mult	

**Table 1.3: Work Product**

#### 1.5.1.6.4 Deliverable Definition Tables

It is the same structure of table as the `Work Product`, only the `Aggregation` is not the same as it can aggregate other `Work Products` or `Deliverables`.

<i>Deliverable</i>	<i>Deliverable</i>		
<b>Package</b>	Location in the MetaModel package		
<b>Brief Description</b>	Short Description.		
<b>Description</b>	Detailed Description		
<b>Kind</b>	Work Product Kind		
<b>Extended by</b>	Deliverables which extend this Deliverable		
<b>Extends</b>	Deliverables which are extended by this Deliverable		
<i>Relation Type</i>	<i>Related Element</i>	<i>Mul.</i>	<i>Note</i>
Aggregates	Which Work Products are aggregated to it	Mult	
Aggregated by	To which Deliverable is it aggregated By	Mult	Description of the context of the Aggregation.
In/out	Which task is producing and consuming the Deliverable	Mult	Description of the Context of production and consumption.
Produced by	Which task is producing the Deliverable	Mult	Description of the context of the production.
Consumed by	Which task is consuming the Deliverable	Mult	Description of the context of the consumption.
Use meta model element	MetamodelElement Relationship	Mult	

**Table 1.4: Deliverable**

### 1.5.1.6.5 Roles Definition Tables

<b>Role</b>	<b>Role</b>		
<b>Package</b>	Meta-model Package Name		
<b>Brief Description</b>	Short Description.		
<b>Description</b>	Detailed Description.		
<b>Relation Type</b>	<b>Related Element</b>	<b>Mul.</b>	<b>Note</b>
Performs	In which task the performer is acting	Mult	

**Table 1.5: Role**

### 1.5.1.6.6 Tools Tables

<b>Tool</b>	<b>Tool</b>		
<b>Package</b>	Meta-model Package name		
<b>Brief Description</b>	Short Description		
<b>Description</b>	Detailed Description		
<b>Kind</b>			
<b>Relation Type</b>	<b>Related Element</b>	<b>Mul.</b>	<b>Note</b>
Used	Task where the tool is used	Mult	

**Table 1.6: Tool**

## 1.5.2 Capability Patterns (Use Case Elements)

The method content (cf. Section 1.5.1) is referenced in section 2.1.2 to describe so-called *Capability Patterns*.

**[TR\_METH\_01029] Capability Patterns definition** [ A *Capability Pattern*<sup>3</sup> is a process pattern that contains a reusable set of activities. ]([RS\\_METH\\_00018](#))

**[TR\_METH\_01030] Composition of Capability Patterns** [ *Capability Patterns* can be assembled to larger *Capability Patterns* that describe development processes or parts of a development process including typical use cases. ]([RS\\_METH\\_00018](#), [RS\\_METH\\_00056](#))

**[TR\_METH\_01031] Adaptability of the AUTOSAR methodology** [ The main focus of this section is merely to provide a use case process flow that can be supported by an AUTOSAR tool chain rather than to define a complete process description. One reason for doing this is that the AUTOSAR methodology should be adaptable to development processes of different organizations. ]([RS\\_METH\\_00056](#))

**[TR\_METH\_01032] Use case elements** [ This section describes the use case elements. The SPEM meta model defines the *Role Use*, the *Work Product Use* and

<sup>3</sup>In Enterprise Architect a SPEM “Capability Pattern” is called “Process Pattern”.

the `Task Use` elements in addition. Whereas these are important elements when applying SPEM in an organization, the AUTOSAR methodology does not necessarily need these elements since no instantiation of the Enterprise Architect model is intended. The elements are thus not used to enhance readability and ease the description. Instead, `Roles`, `Work Products`, `Deliverables` and `Tasks` are used directly to describe the details of an `Activity`.

The element symbols are shown in Figure 1.7. ]

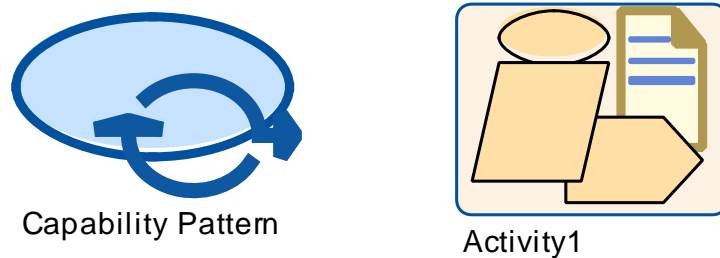


Figure 1.7: Symbols of AUTOSAR Use Case Process Elements

### 1.5.2.1 Activity

**[TR\_METH\_01033] Definition of Activities** [ In the SPEM meta model, an `Activity` is the main building block to define a process. An `Activity` is usually a defined task or work to be done that is commonly executed in one sequence. ]([RS\\_METH\\_00021](#))

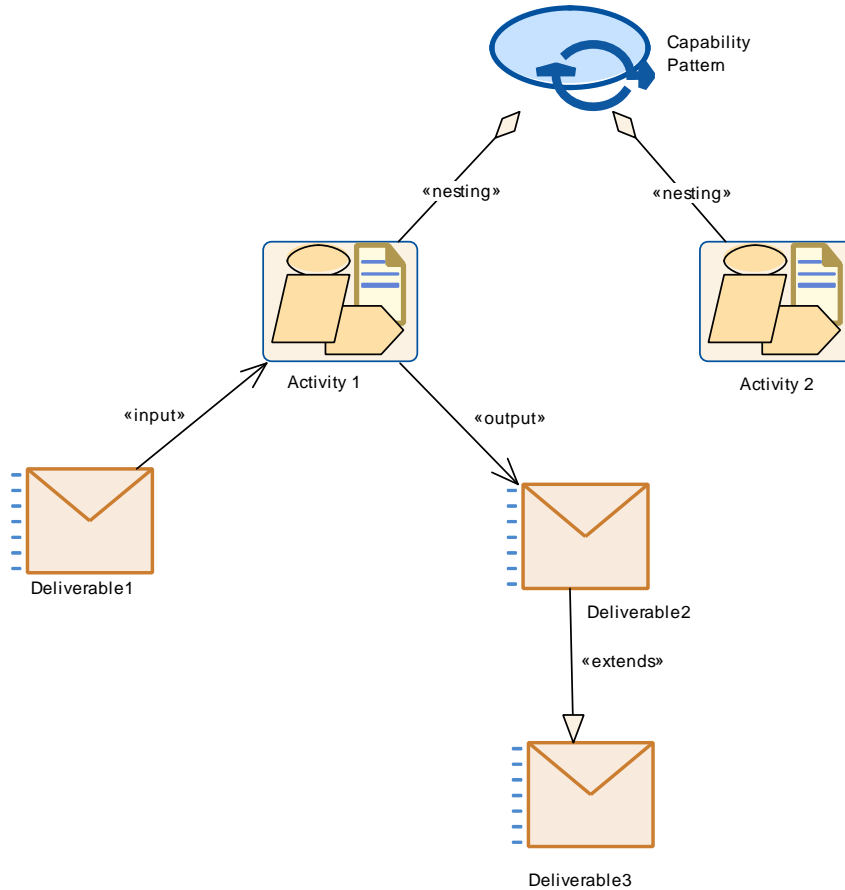
**[TR\_METH\_01034] Composition of Activities** [ `Activities` can include other `Activities` and thereby often decompose a flow of work and show which `Activity` precedes other `Activities` [2]. At the lowest level, `Activities` are collections of work breakdown elements which in AUTOSAR methodology are `Tasks`, `Roles`, and `Work Products`. ]([RS\\_METH\\_00048](#), [RS\\_METH\\_00046](#), [RS\\_METH\\_00047](#), [RS\\_METH\\_00066](#))

**[TR\_METH\_01035] Definition of Processes** [ A `Process` is a special `Activity` in the SPEM meta model that describes a typical structure of development projects or parts of them. A `Process` focuses on the lifecycle and the sequencing of work in breakdown structures. `Processes` contain sequences of `Task` and `Activities` and thereby express a lifecycle of the product under development. `Processes` also define how to get from one milestone to the next by defining sequences of work, operations, or events [2]. ]([RS\\_METH\\_00056](#))

For the AUTOSAR Methodology, the main `Use Cases` are described with 3 types of diagram.

**[TR\_METH\_01036] Description of overall Use Cases** [ In the first diagram, the `Capability Patterns`, `Activities` and `Deliverables` are used to describe the overall `Use Case`, sequence of `Activities` and their main out-

puts(Deliverables). In these diagrams, the predecessor relationship can be skipped and Deliverables can be extended by other Deliverables (see Figure 1.8). ]



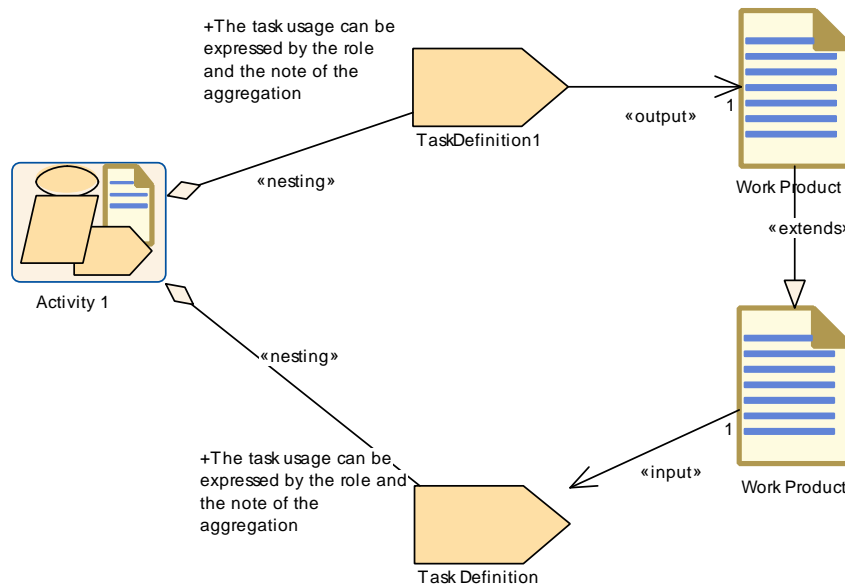
**Figure 1.8: Activity Overview**

The diagram is followed by its corresponding table as detailed hereunder:

<b>Process Pattern</b>	<b>Capability Pattern</b>		
<b>Package</b>	Meta-model Package name		
<b>Brief Description</b>	Short Description		
<b>Description</b>	Detailed Description.		
<b>Relation Type</b>	<b>Related Element</b>	<b>Mul.</b>	<b>Note</b>
Aggregates	Activity nested to the Capability Pattern or to another Activity	Mult	Context explanation
Consumes	Deliverable consumed by the Activity	Mult	Why this Activity needs to consume this Deliverable
Produces	Deliverable produced by the Activity	Mult	Why this Activity is producing this Deliverable

**Table 1.7: Capability Pattern**

[TR\_METH\_01037] **Precise description of Use Cases** [ The second type of diagram are Activities and Task Definition diagrams which precise the main Tasks and Work Products used for the Use Cases but are not as detailed than in the Methodology Library (see Figure 1.9). The task usage in these diagrams will be expressed by the role and in the note at the aggregation. This information will be also visible in the generated table. The Work Products consumed or produced in the use cases will be not integrated in the table for readability. ]



**Figure 1.9: Activity and Tasks Overview**

The diagram is followed by its corresponding table as detailed hereunder:

<b>Activity</b>	<b>Activity</b>		
<b>Package</b>	Meta-model Package Name		
<b>Brief Description</b>	Short Description		
<b>Description</b>	Detailed Description		
<b>Extended by</b>	Activities which extend this Activity		
<b>Extends</b>	Activities which are extended by this Activity		
<b>Relation Type</b>	<b>Related Element</b>	<b>Mul.</b>	<b>Note</b>
Aggregates	Nested task definition	Mult	Task usage description if needed
Consumes	What is Consumed by the Activity	Mult	Explanation on why this Element is needed.
Produces	What is produced by the Activity	Mult	Explanation on why this Element is needed.
In/out	What is produced and consumed by the Activity	Mult	Explanation on why this Element is needed.
Predecessor	Predecessor of the Activity	Mult	Explanation on why the Predecessor is needed.

**Table 1.8: Activity**

**[TR\_METH\_01038] Detailed description of the work flow** [ The third type of diagram contains the `Tasks` and `Work Products` used by an `Activity` in order to show the detailed work flow but not the structure of `Activities` as seen in Section 1.5.1.1. As an example take Figure 2.6. The table generation is not done for this type of diagram. ]

## 1.6 Requirements Traceability

This section states the response of this specification to the corresponding requirements document[1].

Requirement	Description	Satisfied by
[RS_METH_00002]	Methodology shall explain the typical usage of SW-C template	<a href="#">[TR_METH_01044]</a> <a href="#">[TR_METH_01047]</a> <a href="#">[TR_METH_01048]</a> <a href="#">[TR_METH_01050]</a> <a href="#">[TR_METH_01051]</a> <a href="#">[TR_METH_01052]</a> <a href="#">[TR_METH_01053]</a> <a href="#">[TR_METH_01054]</a> <a href="#">[TR_METH_01055]</a> <a href="#">[TR_METH_01056]</a> <a href="#">[TR_METH_01057]</a> <a href="#">[TR_METH_01058]</a> <a href="#">[TR_METH_01059]</a> <a href="#">[TR_METH_01060]</a> <a href="#">[TR_METH_01061]</a> <a href="#">[TR_METH_01065]</a> <a href="#">[TR_METH_01066]</a> <a href="#">[TR_METH_01067]</a> <a href="#">[TR_METH_01068]</a> <a href="#">[TR_METH_01071]</a> <a href="#">[TR_METH_01075]</a> <a href="#">[TR_METH_01076]</a> <a href="#">[TR_METH_01077]</a> <a href="#">[TR_METH_01078]</a> <a href="#">[TR_METH_01079]</a> <a href="#">[TR_METH_01080]</a> <a href="#">[TR_METH_01081]</a> <a href="#">[TR_METH_01082]</a> <a href="#">[TR_METH_01087]</a> <a href="#">[TR_METH_01088]</a> <a href="#">[TR_METH_01090]</a> <a href="#">[TR_METH_01091]</a> <a href="#">[TR_METH_01110]</a> <a href="#">[TR_METH_01112]</a> <a href="#">[TR_METH_01125]</a> <a href="#">[TR_METH_01126]</a> <a href="#">[TR_METH_01127]</a> <a href="#">[TR_METH_02000]</a> <a href="#">[TR_METH_02001]</a> <a href="#">[TR_METH_02002]</a> <a href="#">[TR_METH_02005]</a> <a href="#">[TR_METH_02006]</a> <a href="#">[TR_METH_02007]</a> <a href="#">[TR_METH_02008]</a> <a href="#">[TR_METH_03000]</a> <a href="#">[TR_METH_03005]</a> <a href="#">[TR_METH_03006]</a> <a href="#">[TR_METH_03007]</a>



Requirement	Description	Satisfied by
[RS_METH_00003]	Methodology shall explain the typical usage of BSW Module Template	<a href="#">[TR_METH_01083]</a> <a href="#">[TR_METH_01084]</a> <a href="#">[TR_METH_01085]</a> <a href="#">[TR_METH_01087]</a> <a href="#">[TR_METH_01088]</a> <a href="#">[TR_METH_01089]</a> <a href="#">[TR_METH_01090]</a> <a href="#">[TR_METH_01091]</a> <a href="#">[TR_METH_01092]</a> <a href="#">[TR_METH_01111]</a> <a href="#">[TR_METH_01112]</a> <a href="#">[TR_METH_01114]</a> <a href="#">[TR_METH_01115]</a> <a href="#">[TR_METH_01117]</a> <a href="#">[TR_METH_02002]</a> <a href="#">[TR_METH_02005]</a> <a href="#">[TR_METH_03000]</a> <a href="#">[TR_METH_03010]</a>
[RS_METH_00004]	Methodology shall explain the typical usage of the ECU Configuration template	<a href="#">[TR_METH_01083]</a> <a href="#">[TR_METH_01086]</a> <a href="#">[TR_METH_01087]</a> <a href="#">[TR_METH_01088]</a> <a href="#">[TR_METH_01089]</a> <a href="#">[TR_METH_01090]</a> <a href="#">[TR_METH_01091]</a> <a href="#">[TR_METH_01092]</a> <a href="#">[TR_METH_01095]</a> <a href="#">[TR_METH_01098]</a> <a href="#">[TR_METH_01103]</a> <a href="#">[TR_METH_01104]</a> <a href="#">[TR_METH_01107]</a> <a href="#">[TR_METH_01112]</a> <a href="#">[TR_METH_01114]</a> <a href="#">[TR_METH_01115]</a> <a href="#">[TR_METH_01116]</a> <a href="#">[TR_METH_01117]</a> <a href="#">[TR_METH_02005]</a> <a href="#">[TR_METH_03000]</a>

Requirement	Description	Satisfied by
[RS_METH_00005]	Methodology shall explain the typical usage of the System Template	<a href="#">[TR_METH_01046]</a> <a href="#">[TR_METH_01047]</a> <a href="#">[TR_METH_01048]</a> <a href="#">[TR_METH_01053]</a> <a href="#">[TR_METH_01065]</a> <a href="#">[TR_METH_01066]</a> <a href="#">[TR_METH_01067]</a> <a href="#">[TR_METH_01068]</a> <a href="#">[TR_METH_01070]</a> <a href="#">[TR_METH_01071]</a> <a href="#">[TR_METH_01075]</a> <a href="#">[TR_METH_01076]</a> <a href="#">[TR_METH_01077]</a> <a href="#">[TR_METH_01078]</a> <a href="#">[TR_METH_01079]</a> <a href="#">[TR_METH_01080]</a> <a href="#">[TR_METH_01081]</a> <a href="#">[TR_METH_01082]</a> <a href="#">[TR_METH_01087]</a> <a href="#">[TR_METH_01088]</a> <a href="#">[TR_METH_01090]</a> <a href="#">[TR_METH_01091]</a> <a href="#">[TR_METH_01092]</a> <a href="#">[TR_METH_01109]</a> <a href="#">[TR_METH_01112]</a> <a href="#">[TR_METH_01114]</a> <a href="#">[TR_METH_01125]</a> <a href="#">[TR_METH_01126]</a> <a href="#">[TR_METH_01127]</a> <a href="#">[TR_METH_02003]</a> <a href="#">[TR_METH_02006]</a> <a href="#">[TR_METH_02007]</a> <a href="#">[TR_METH_02008]</a> <a href="#">[TR_METH_02015]</a> <a href="#">[TR_METH_02016]</a> <a href="#">[TR_METH_02017]</a> <a href="#">[TR_METH_02018]</a> <a href="#">[TR_METH_03000]</a> <a href="#">[TR_METH_03008]</a>

Requirement	Description	Satisfied by
[RS_METH_00006]	Methodology shall explain how Autosar system is built	[TR_METH_01003] [TR_METH_01039] [TR_METH_01044] [TR_METH_01045] [TR_METH_01046] [TR_METH_01047] [TR_METH_01048] [TR_METH_01049] [TR_METH_01061] [TR_METH_01085] [TR_METH_01087] [TR_METH_01092] [TR_METH_01093] [TR_METH_01109] [TR_METH_01110] [TR_METH_01111] [TR_METH_01112] [TR_METH_01114] [TR_METH_03002] [TR_METH_03003] [TR_METH_03004]
[RS_METH_00009]	Methodology should be modeled	[TR_METH_01001] [TR_METH_01002] [TR_METH_01004] [TR_METH_01009]
[RS_METH_00010]	Methodology should define rules to translate methodology model into a document	[TR_METH_01121]
[RS_METH_00015]	Methodology shall be independent of programming language	[TR_METH_01018]
[RS_METH_00016]	Methodology shall support building a system of both Autosar and Non-Autosar ECUs	[TR_METH_01019]
[RS_METH_00017]	Methodology shall clearly define what is standardized and what is not standardized	[TR_METH_01008] [TR_METH_01019]
[RS_METH_00018]	Methodology shall be modular	[TR_METH_01000] [TR_METH_01002] [TR_METH_01004] [TR_METH_01006] [TR_METH_01007] [TR_METH_01021] [TR_METH_01022] [TR_METH_01029] [TR_METH_01030] [TR_METH_01084] [TR_METH_01110]
[RS_METH_00020]	Methodology shall support iterations	[TR_METH_01071] [TR_METH_01089] [TR_METH_02004]

Requirement	Description	Satisfied by
[RS_METH_00021]	Methodology shall define Activities	[TR_METH_01006] [TR_METH_01007] [TR_METH_01010] [TR_METH_01011] [TR_METH_01012] [TR_METH_01013] [TR_METH_01033]
[RS_METH_00025]	Methodology shall define Work products	[TR_METH_01001] [TR_METH_01006] [TR_METH_01007] [TR_METH_01010] [TR_METH_01014] [TR_METH_01021] [TR_METH_01022]
[RS_METH_00027]	Methodology shall define unambiguous guidance terminology	[TR_METH_01010] [TR_METH_01026] [TR_METH_01027]
[RS_METH_00028]	Methodology shall define Roles	[TR_METH_01001] [TR_METH_01006] [TR_METH_01007] [TR_METH_01010] [TR_METH_01023] [TR_METH_01024]
[RS_METH_00032]	The methodology shall respect the different levels of Abstractions	[TR_METH_01000] [TR_METH_01040]
[RS_METH_00033]	Methodology should support VFB concept	[TR_METH_01039] [TR_METH_01045] [TR_METH_01054] [TR_METH_02000]
[RS_METH_00038]	Methodology shall support the C programming language	[TR_METH_01060] [TR_METH_01085] [TR_METH_01093] [TR_METH_02005] [TR_METH_03001]
[RS_METH_00041]	Methodology shall support Bottom/Up Approach	[TR_METH_01071]
[RS_METH_00042]	Methodology shall incorporate the usage of industry standard tools	[TR_METH_01010] [TR_METH_01013] [TR_METH_01025] [TR_METH_01093]
[RS_METH_00043]	Activities shall have a purpose	[TR_METH_01008]
[RS_METH_00046]	Activities shall have input work products	[TR_METH_01014] [TR_METH_01034]
[RS_METH_00047]	Activities shall have output work products	[TR_METH_01005] [TR_METH_01006] [TR_METH_01014] [TR_METH_01034]
[RS_METH_00048]	Activities shall include roles	[TR_METH_01006] [TR_METH_01034]
[RS_METH_00050]	Work products shall have a description	[TR_METH_01008] [TR_METH_01028]

Requirement	Description	Satisfied by
[RS_METH_00051]	Work products shall have a reference(s) to metaclass(es) in the Autosar Metamodel.	[TR_METH_01020]
[RS_METH_00052]	It must be possible to avoid duplication of data in Work Products	[TR_METH_01014] [TR_METH_01015] [TR_METH_01017]
[RS_METH_00054]	Work Products shall not have circular references with other work products	[TR_METH_01014] [TR_METH_01017] [TR_METH_01021] [TR_METH_01022] [TR_METH_01122]
[RS_METH_00056]	AUTOSAR methodology shall not be bound to a particular lifecycle model	[TR_METH_01002] [TR_METH_01004] [TR_METH_01006] [TR_METH_01012] [TR_METH_01024] [TR_METH_01030] [TR_METH_01031] [TR_METH_01035]
[RS_METH_00057]	AUTOSAR methodology shall support traceability to external artifacts	[TR_METH_01018] [TR_METH_01123]
[RS_METH_00061]	Methodology shall describe the change of existing work products.	[TR_METH_01006] [TR_METH_01014] [TR_METH_01015] [TR_METH_01017]
[RS_METH_00062]	Methodology shall support configuration of parameters with different binding time.	[TR_METH_01086] [TR_METH_01095] [TR_METH_01098] [TR_METH_01104] [TR_METH_01107]
[RS_METH_00063]	Work Products shall be capable to be version controlled	[TR_METH_01018] [TR_METH_01019]
[RS_METH_00064]	Roles shall have a description	[TR_METH_01008] [TR_METH_01028]
[RS_METH_00066]	Activities shall include tools	[TR_METH_01025] [TR_METH_01034]
[RS_METH_00067]	Methodology document shall include hyperlinks between Activities, Roles, Work Products, and Guidance.	[TR_METH_01113]
[RS_METH_00069]	It shall be possible to add precise and human readable documentation to each work product.	[TR_METH_01123] [TR_METH_01124]
[RS_METH_00074]	Methodology shall specify Binding times	[TR_METH_00001] [TR_METH_00002] [TR_METH_00003] [TR_METH_02011] [TR_METH_02012] [TR_METH_02013] [TR_METH_02014] [TR_METH_02020]

Requirement	Description	Satisfied by
[RS_METH_00075]	Methodology shall specify the tasks of resolving variant	[TR_METH_00001] [TR_METH_02016]
[RS_METH_00076]	Methodology shall specify a work product for values of variant selectors	[TR_METH_02016] [TR_METH_02017]
[RS_METH_00077]	Methodology shall explain the typical interaction between OEMs and suppliers	[TR_METH_01049] [TR_METH_01076] [TR_METH_01079] [TR_METH_01080] [TR_METH_01081] [TR_METH_01082] [TR_METH_01125] [TR_METH_01126] [TR_METH_01127]
[RS_METH_00078]	Methodology shall explain the typical usage of different views on the system of the OEM	[TR_METH_01044] [TR_METH_01050] [TR_METH_01068]
[RS_METH_00079]	Methodology shall explain the typical usage of different views on the system of the Supplier	[TR_METH_01068] [TR_METH_01079] [TR_METH_01080] [TR_METH_01081] [TR_METH_01082]
[RS_METH_00080]	Exchange of Implicit Communication Behavior Description	[TR_METH_01120]

Some input requirements cannot (or not completely) be traced down to single specification items found in this document. They are satisfied by the AUTOSAR methodology in a general way together with other documents as listed in the following:

**[TR\_METH\_01120] Definition of Consistency Needs** [ The AUTOSAR methodology supports the exchange of implicit communication behavior description. Chapters 3.4.1.15 and 3.4.2.17 depict the task and the artifact which allow to define the corresponding consistency needs. ]([RS\\_METH\\_00080](#))

**[TR\_METH\_01121] Building the AUTOSAR methodology document** [ All AUTOSAR methodology related model elements (see 1.5) are consumed by an internal AUTOSAR tool that automatically produces the corresponding text, tables, and diagrams. These artifacts are included into a document which is automatically transformed into the final PDF file. ]([RS\\_METH\\_00010](#))

**[TR\_METH\_01122] Relations between AUTOSAR Work Products** [ Work Products (Deliverables and Artifacts) are designed in such a way that no circular references with other Work Products exist. ]([RS\\_METH\\_00054](#))

**[TR\_METH\_01123] Traceability to external artifacts** [ Artifacts considered in the Methodology model include external artifacts like c-code, libraries, documentation and generated artifacts (see e.g. 3.5.2.22, 3.4.2.4). *General Non Autosar Artifact* is a generic representation of non AUTOSAR artifacts. It is aggregated by the *General Deliverable* and allows linking and tracing of non AUTOSAR artifacts within the AUTOSAR context. Furthermore, several specific artifacts represent non AUTOSAR

elements or allow referring to them. The [A2L File](#) artifact is a representation of the measurement and calibration format that is defined by the ASAM and therefore out of scope of AUTOSAR. The description of the [Atomic Software Component Implementation](#) artifact explains how external artifacts can be referred from this ARXML artifact. [|\(RS\\_METH\\_00057, RS\\_METH\\_00069\)](#)

**[TR\_METH\_01124] Documentation of Work Products** [|](#) In order to document design decisions or restrictions during the development process each `Work Product` can aggregate the corresponding documentation which is represented by the [General Documentation](#) artifact. The [General Documentation](#) artifact is added to `Work Products` by processing the task [Add General Documentation](#). [|\(RS\\_METH\\_00069\)](#)

## 2 Use Cases

### 2.1 Overall View

#### 2.1.1 Purpose

This pattern provides a rough outline of the design steps to build a system and resultant of this the ECUs and the topology with the AUTOSAR methodology. The main activities are depicted in Figure 2.1.

#### 2.1.2 Description

##### 2.1.2.1 Views on the System

**[TR\_METH\_01039] AUTOSAR System development overview** [ The development of an AUTOSAR System is based on the definition of the `Virtual Functional Bus (VFB)`. The VFB is the communication mechanism that allows a composition of interconnected software components to interact. Based on the VFB the system is designed. ]([RS\\_METH\\_00006](#), [RS\\_METH\\_00033](#))

**[TR\_METH\_01040] Support of different system views** [ During the overall development of the system, different views on the system can exist (e.g. functional architecture, or software architecture). These views are described explicitly, whereas a mapping mechanism is used to express the relation between them. ]([RS\\_METH\\_00032](#))

In the following three different views on the system are distinguished:

- **[TR\_METH\_01041] Abstract system** [ The abstract system abstracts from the concrete software architecture and describes e.g. the functional view on the system. ]
- **[TR\_METH\_01042] Overall technical system** [ The overall technical system is organized from the software architecture perspective. ]
- **[TR\_METH\_01043] Sub-System** [ The Sub-System is a reduced part of the overall technical System and describes relevant aspects for a dedicated subsystem. ]

##### 2.1.2.2 Overall Workflow

**[TR\_METH\_01044] Development of a functional view on the system** [ The overall workflow (see Figure 2.2) starts with an optional activity. In this activity, the [Abstract System Description](#) is developed in advance, which represents the overall system from a functional or abstract view (functional architecture). This [Abstract System](#)



[Description](#) is then the basis for the development of the concrete [System Description](#). ]([RS\\_METH\\_00006](#), [RS\\_METH\\_00002](#), [RS\\_METH\\_00078](#))

**[TR\_METH\_01045] Development of the Overall VFB System** [ In case of omitting the optional first step, the development directly starts with the definition of the [Overall VFB System](#). The VFB provides a software architecture oriented view of all the functions the system supports, independent of any ECUs and networks. See chapter [2.3](#) for more details. ]([RS\\_METH\\_00006](#), [RS\\_METH\\_00033](#))

**[TR\_METH\_01046] Development of the system** [ The VFB is refined into a system by defining a topology of ECUs and Networks, deploying software components to the ECUs, and deriving the communication matrices required to interconnect the distributed features. This can be achieved directly in one phase or in several phases (the use case shows a single phase and a two phase approach). ]([RS\\_METH\\_00006](#), [RS\\_METH\\_00005](#))

**[TR\_METH\_01047] Two phase development approach** [ The two phase approach is used when there is an organizational separation of responsibility where the primary organization defines the overall system in the first phase, and several other organizations define the sub-systems in parallel during the second phase. In this case, the primary organization hands over [System Extracts](#), which represent subsystem parts of the whole system. These subsystems contain Subsystem VFBs which are reduced overall VFBs. ]([RS\\_METH\\_00006](#), [RS\\_METH\\_00002](#), [RS\\_METH\\_00005](#))

**[TR\_METH\_01048] The overall system** [ The overall system defines the major public ECUs and topologies, and the subsystem design contributes by adding private ECUs and networks to the system. Please note that portions defined within a subsystem are not directly visible to any other subsystem or to the overall system. ]([RS\\_METH\\_00006](#), [RS\\_METH\\_00005](#), [RS\\_METH\\_00002](#))

**[TR\_METH\_01049] Interaction between organizations** [ Additionally, the software component structure of the [System Extracts](#), delivered by the primary organization can be transformed into a different structure by the receiving organization ([ECU System Description](#)). In this case the [System Extract](#) of the primary organization can be considered as a requirement and the subsystem of the receiving organization represented by one or more [ECU System Descriptions](#) can be seen as a solution which has to fulfill the delivered requirements. ]([RS\\_METH\\_00006](#), [RS\\_METH\\_00077](#))

**[TR\_METH\_01109] Producing ECU-specific deliverables** [ After the system design is complete, the portions that are related to a specific ECU are extracted producing a deliverable for each ECU. This is elaborated further in chapter [2.5](#). ]([RS\\_METH\\_00006](#), [RS\\_METH\\_00005](#))

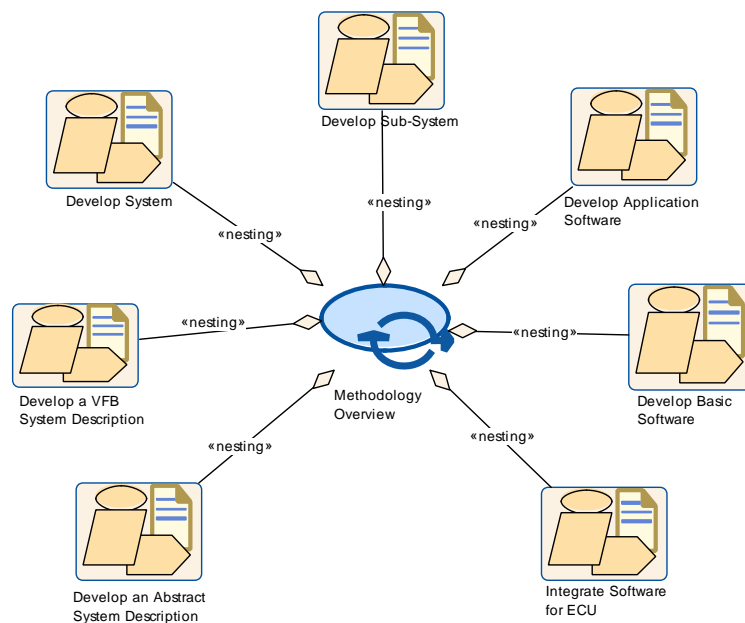
**[TR\_METH\_01110] Development of Software Components** [ In parallel to the system design, the software components ([Delivered Atomic Software Components](#)) are implemented according to the definitions required by the abstract VFB, the VFB or the subsystem VFB. These are delivered to be integrated in the ECUs

where they are deployed. Please note that the implementation of a software component is more or less independent from ECU configuration. This is a key feature of the AUTOSAR methodology. See chapter 2.4 for more details. ]([RS\\_METH\\_00006](#), [RS\\_METH\\_00002](#), [RS\\_METH\\_00018](#))

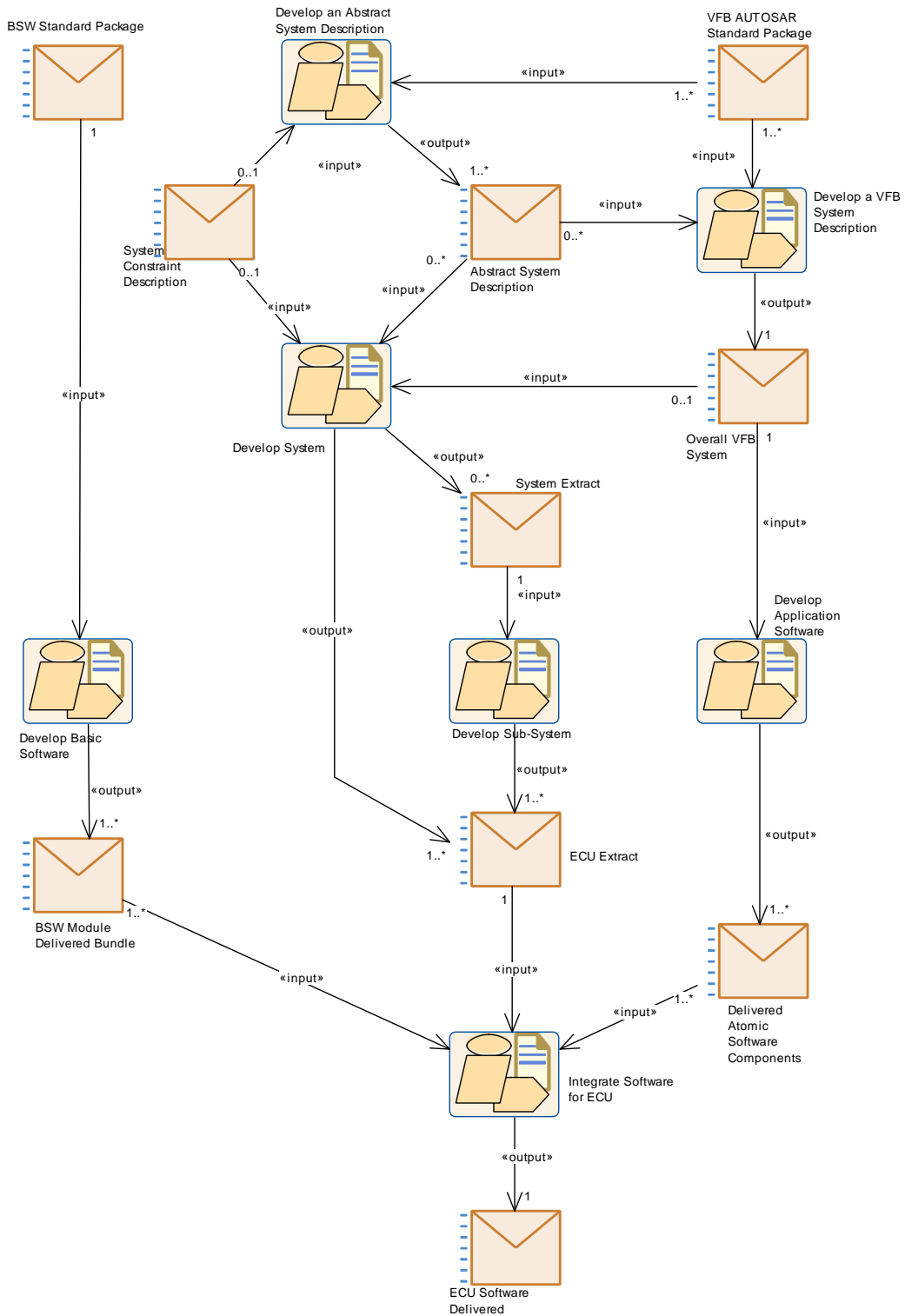
**[TR\_METH\_01111] Development of Basic Software modules** [ Since the Basic Software modules are independent of the VFB, they can be developed at any time before ECU integration. See chapter 2.6 for more details. ]([RS\\_METH\\_00006](#), [RS\\_METH\\_00003](#))

**[TR\_METH\_01112] Integration of AUTOSAR ECUs** [ The integration for an AUTOSAR ECU commences when the [BSW Module Delivered Bundles](#), [ECU Extract](#), and the implementation of all [Delivered Atomic Software Components](#) are available. At this stage, the ECU is configured by creating tasks, scheduling Software Component Runnables, configuring the Basic Software Modules, etc. The complete code is compiled and linked into an executable. This is elaborated in chapter 2.7. ]([RS\\_METH\\_00006](#), [RS\\_METH\\_00002](#), [RS\\_METH\\_00003](#), [RS\\_METH\\_00004](#), [RS\\_METH\\_00005](#))

### 2.1.3 Workflow



**Figure 2.1: Methodology Overview: Overall Structure**



**Figure 2.2: Methodology Overview: Work Flow**

<b>Process Pattern</b>	<b>Methodology Overview</b>		
<b>Package</b>	AUTOSAR Root::M2::Methodology::Methodology Use Cases::High Level::Methodology Overview		
<b>Brief Description</b>	High level view of the AUTOSAR Methodology		
<b>Description</b>	This Process Patterns contains the typical activities to develop an AUTOSAR system.		
<b>Relation Type</b>	<b>Related Element</b>	<b>Mul.</b>	<b>Note</b>
Aggregates	<a href="#">Develop Application Software</a>	1	
Aggregates	<a href="#">Develop Basic Software</a>	1	
Aggregates	<a href="#">Develop Sub-System</a>	1	
Aggregates	<a href="#">Develop System</a>	1	
Aggregates	<a href="#">Develop a VFB System Description</a>	1	
Aggregates	<a href="#">Develop an Abstract System Description</a>	1	
Aggregates	<a href="#">Integrate Software for ECU</a>	1	

**Table 2.1: Methodology Overview**

## 2.2 Develop an Abstract System Description

### 2.2.1 Purpose

This [Activity](#) provides a rough outline of the creation of the [Abstract System Description](#).

### 2.2.2 Description

**[TR\_METH\_01050] [Abstract System Description activity](#)** [ Due to the fact that the overall view on vehicle functions can differ from the actual technical definition of the software architectures of individual ECUs, the optional activity [Develop an Abstract System Description](#) allows to define a view on the overall system from an abstract or functional perspective. This view describes a dedicated abstract VFB. During the further activities this abstract view is refactored into a technical view of the software architecture. ] ([RS\\_METH\\_00002](#), [RS\\_METH\\_00078](#))

For the purpose of this use case, this activity is split into sub-activities and tasks (see [Figure 2.3](#)) that are in Detail described in [Chapter 2.3](#) and [2.5.2](#):

- [Data Model Development](#)

- [Component Model Development](#)
- [VFB Timing Development](#)
- [Define VFB Top Level](#)
- [Define VFB Component Constraints](#)
- [Design System](#)

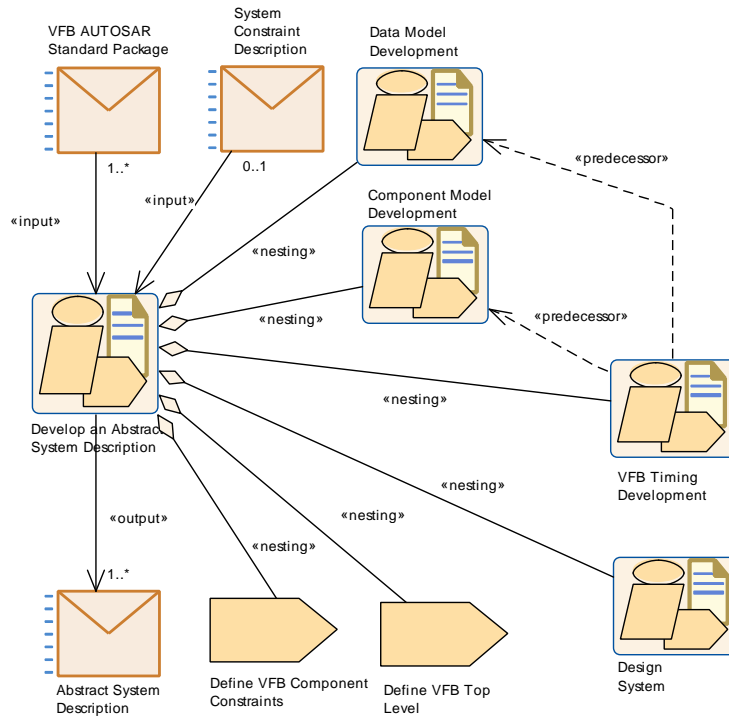
In the [Data Model Development](#) activity, the set of VFB Interfaces, VFB Modes, and VFB Types that are used throughout the abstract VFB are defined. Please note, that these objects can be used in later steps by the VFB and the subsystem VFB as well.

**[TR\_METH\_01051] Creation of an overall abstract system** [ In the [Component Model Development](#) activity, a component model is created which represents the overall system from a functional point of view, e.g. from a customer related perspective of vehicle functions, independent of a concrete vehicle platform design. During this process compositions might be modeled, which are not further refined into Atomic Software Components. However it is also possible to define atomic software components as well in this abstract VFB view. ]([RS\\_METH\\_00002](#))

**[TR\_METH\_01052] Definition of a constraints in the context of an abstract system** [ In the context of the abstract VFB, the task [Define VFB Component Constraints](#) defines constraints w.r.t. software components of the abstract VFB. These constraints have to be considered when the abstract VFB is transformed into the concrete, technical VFB. ]([RS\\_METH\\_00002](#))

**[TR\_METH\_01053] Definition of a [System Description](#) in the context of an abstract system** [ Additionally to the definition of the abstract VFB, parts of the [System Description](#) can already be defined in the [Design System](#) activity, e.g. the topology and ECUs where SWCs of the abstract VFB are mapped to. This SW-C mapping from the abstract VFB to ECUs can be used as a methodological step to the definition of the concrete VFB. Please note that not all tasks of the [Design System](#) activity have to be performed in the context of an abstract system. ]([RS\\_METH\\_00002](#), [RS\\_METH\\_00005](#))

**2.2.3 Workflow**



**Figure 2.3: Develop an Abstract System Description**

<b>Activity</b>	<b>Develop an Abstract System Description</b>		
<b>Package</b>	AUTOSAR Root::M2::Methodology::Methodology Use Cases::System::Develop System		
<b>Brief Description</b>	Develop an abstract or functional view on the system.		
<b>Description</b>	This activity defines an abstract view on the overall system from an abstract or functional point of view. This activity is optional.		
<b>Relation Type</b>	<b>Related Element</b>	<b>Mul.</b>	<b>Note</b>
Consumes	<a href="#">System Constraint Description</a>	0..1	In the context of the "Develop an Abstract System Description" activity, the constraints for the abstract or functional view on the system can be provided by the "System Constraint Description".
Consumes	<a href="#">VFB AUTOSAR Standard Package</a>	1..*	
Produces	<a href="#">Abstract System Description</a>	1..*	
Aggregates	<a href="#">Component Model Development</a>	1	
Aggregates	<a href="#">Data Model Development</a>	1	
Aggregates	<a href="#">Define VFB Component Constraints</a>	1	
Aggregates	<a href="#">Define VFB Top Level</a>	1	

<i>Relation Type</i>	<i>Related Element</i>	<i>Mul.</i>	<i>Note</i>
Aggregates	<a href="#">Design System</a>	1	In the context of the Develop an Abstract System Description activity, not all tasks have to be performed.
Aggregates	<a href="#">VFB Timing Development</a>	1	

**Table 2.2: Develop an Abstract System Description**

## 2.3 Develop a VFB System Description

### 2.3.1 Purpose

This *Activity* provides a rough outline of the creation of a *Virtual Functional Bus* view of a *System*. [2]

### 2.3.2 Description

**[TR\_METH\_01054] Virtual Functional Bus** [ The *Virtual Functional Bus* (VFB) view of a *System* shows how the *Systems* software functions interact independently of any network topology or deployment of features across multiple *ECUs*. ]([RS\\_METH\\_00033](#), [RS\\_METH\\_00002](#))

For more information on the VFB concept see [3]. For detailed information on the meta-model parts relevant for the VFB see [4].

For the purpose of this use case, this *Activity* is split into three sub-activities:

- [Data Model Development](#)
- [Component Model Development](#)
- [VFB Timing Development](#)

**[TR\_METH\_01055] Data Model Development activity** [ In the [Data Model Development](#), the set of [VFB Interfaces](#), [VFB Modes](#), and [VFB Types](#) that are used throughout the VFB are defined. Some of these have already been pre-defined by AUTOSAR (so-called “blueprints”), see [3.2.2.7](#) ]([RS\\_METH\\_00002](#))

**[TR\_METH\_01056] Definition of the VFB** [ In the [Component Model Development](#) activity, the VFB is defined. This can either be done by the use of the abstract VFB as a basis, or is done directly by defining the software components. In case of using the abstract VFB as a basis, a mapping between the abstract and the concrete VFB can be established by performing the tasks [Define System View Mapping](#) (see Section [3.3.1.15](#) for more details). ]([RS\\_METH\\_00002](#))

Two general approaches can be separated:

- **[TR\_METH\_01057] Top-Down approach** [ Following a Top-Down approach, the highest level [VFB Composition Components](#) are created, and these are iteratively broken down to smaller components. At the leaves of the hierarchy the [VFB Atomic Software Component](#) are defined. Note that the activity can be even finished with empty [VFB Composition Components](#), allowing the detailing of the further structure at a later stage. ]([RS\\_METH\\_00002](#))
- **[TR\_METH\_01058] Bottom-Up approach** [ If a Bottom-Up approach is used, then the [VFB Atomic Software Components](#) are first defined, and aggregated into [VFB Composition Components](#). ]([RS\\_METH\\_00002](#))

**[TR\_METH\_01059] Kinds of VFB Atomic Software Components** [ Several special kinds of [VFB Atomic Software Components](#) can be modeled in this activity:

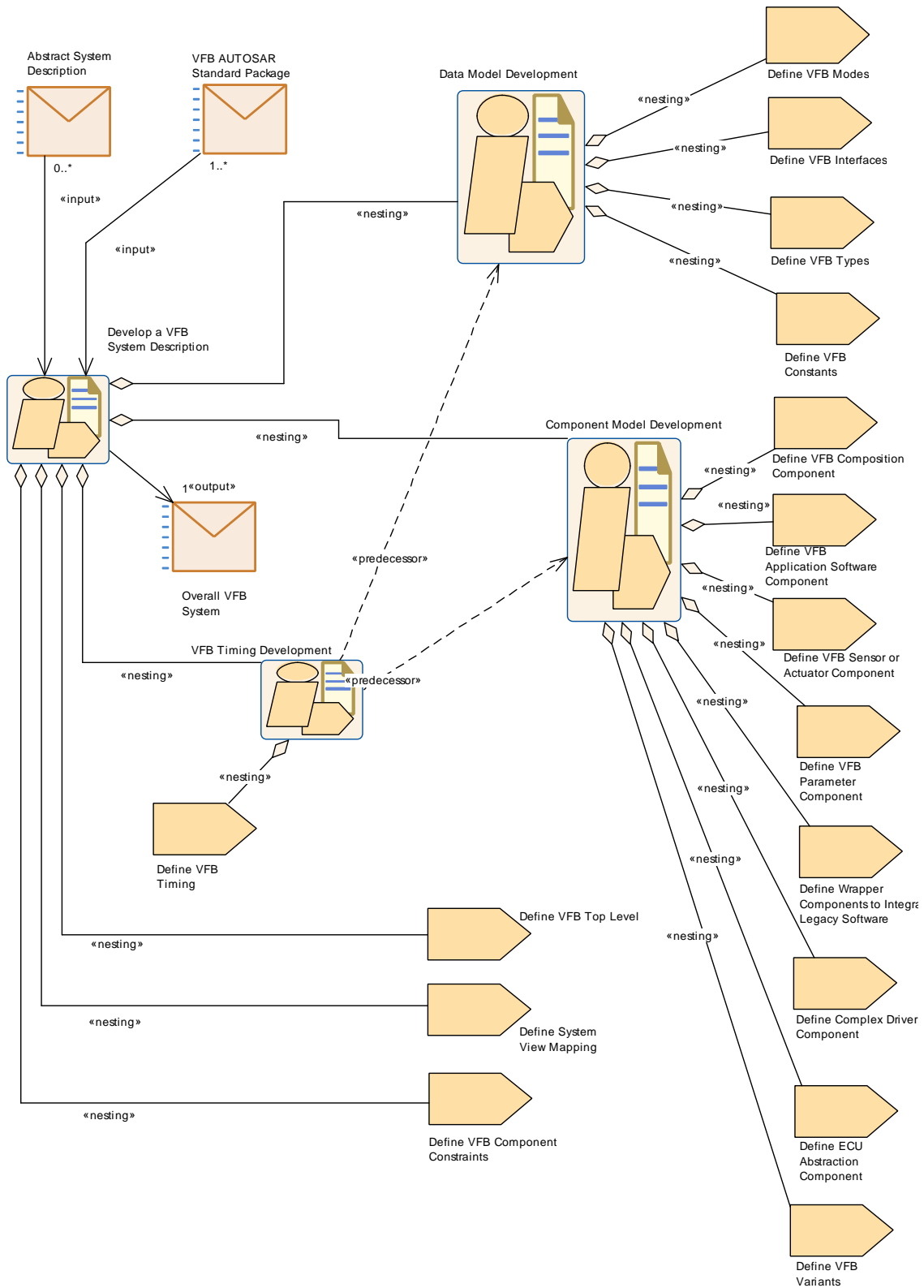
- [VFB Atomic Application Software Components](#) are the core elements. They are used to implement the feature algorithms.
- [VFB Parameter Component](#) are used to provide characteristic values, such as calibration parameters, to software components.
- [VFB Sensor Actuator Components](#) provide the connection between physical sensors/actuators and the [VFB Atomic Application Software Components](#).
- [ECU Abstraction Software Components](#) can be modeled at this level as well in order to model the ECU input and output interfaces which are used by sensors and actuators.
- [Complex Driver Components](#) also have to be modeled here, though their implementation is ECU specific, because their ports need to be connected at the VFB level.
- Empty [VFB Composition Components](#) can be provided in case the detailed structure of the desired solution is not in the scope of this activity and will be left open to a later stage in the development.

]([RS\\_METH\\_00002](#))

After these activities are completed, the [Virtual Functional Bus](#) view of the System is defined. At this point, some [VFB Software Component Mapping Constraints](#) may already be known by design, or based on analyzes such as [Define VFB Timing](#). These can be described to provide guidance to the downstream activities.



### 2.3.3 Workflow



**Figure 2.4: Develop a VFB System Description**

<b>Activity</b>	<b>Develop a VFB System Description</b>		
<b>Package</b>	AUTOSAR Root::M2::Methodology::Methodology Use Cases::VFB::Develop VFB		
<b>Brief Description</b>	This pattern describes the methodology to develop the Virtual Functional Bus view of the System.		
<b>Description</b>	<p>The Virtual Functional Bus (VFB) view of a System shows how the Systems software and hardware functions interact independent of any network topology or deployment of features across multiple ECUs. This Activity is split into three sub-activities:</p> <ul style="list-style-type: none"> <li>• Data Model Development</li> <li>• Component Model Development</li> <li>• Timing Model Development.</li> </ul>		
<b>Relation Type</b>	<b>Related Element</b>	<b>Mul.</b>	<b>Note</b>
Consumes	<a href="#">Abstract System Description</a>	0..*	The abstract System Description is an optional input for the activity "Develop a VFB System Description". The VFB-related part of the Abstract System Description can be then refined to the concrete "Overall VFB System". Additionally, a mapping between those two views can be established.
Consumes	<a href="#">VFB AUTOSAR Standard Package</a>	1..*	
Produces	<a href="#">Overall VFB System</a>	1	
Aggregates	<a href="#">Component Model Development</a>	1	
Aggregates	<a href="#">Data Model Development</a>	1	
Aggregates	<a href="#">Define System View Mapping</a>	1	
Aggregates	<a href="#">Define VFB Component Constraints</a>	1	
Aggregates	<a href="#">Define VFB Top Level</a>	1	
Aggregates	<a href="#">VFB Timing Development</a>	1	

**Table 2.3: Develop a VFB System Description**

<b>Activity</b>	<b>Data Model Development</b>		
<b>Package</b>	AUTOSAR Root::M2::Methodology::Methodology Use Cases::VFB::Develop VFB		
<b>Brief Description</b>			
<b>Description</b>			
<b>Relation Type</b>	<b>Related Element</b>	<b>Mul.</b>	<b>Note</b>
Aggregates	<a href="#">Define VFB Constants</a>	1	

<i>Relation Type</i>	<i>Related Element</i>	<i>Mul.</i>	<i>Note</i>
Aggregates	Define VFB Interfaces	1	
Aggregates	Define VFB Modes	1	
Aggregates	Define VFB Types	1	

**Table 2.4: Data Model Development**

<i>Activity</i>	<b>Component Model Development</b>		
<b>Package</b>	AUTOSAR Root::M2::Methodology::Methodology Use Cases::VFB::Develop VFB		
<b>Brief Description</b>			
<b>Description</b>			
<i>Relation Type</i>	<i>Related Element</i>	<i>Mul.</i>	<i>Note</i>
Aggregates	Define Complex Driver Component	1	
Aggregates	Define ECU Abstraction Component	1	
Aggregates	Define VFB Application Software Component	1	
Aggregates	Define VFB Composition Component	1	
Aggregates	Define VFB Parameter Component	1	
Aggregates	Define VFB Sensor or Actuator Component	1	
Aggregates	Define VFB Variants	1	
Aggregates	Define Wrapper Components to Integrate Legacy Software	1	

**Table 2.5: Component Model Development**

<i>Activity</i>	<b>VFB Timing Development</b>		
<b>Package</b>	AUTOSAR Root::M2::Methodology::Methodology Use Cases::VFB::Develop VFB		
<b>Brief Description</b>			
<b>Description</b>			
<i>Relation Type</i>	<i>Related Element</i>	<i>Mul.</i>	<i>Note</i>
Aggregates	Define VFB Timing	1	
Predecessor	Component Model Development	1	

<i>Relation Type</i>	<i>Related Element</i>	<i>Mul.</i>	<i>Note</i>
Predecessor	<a href="#">Data Model Development</a>	1	

**Table 2.6: VFB Timing Development**

## 2.4 Develop Software Components

### 2.4.1 Develop an Atomic Software Component

#### 2.4.1.1 Purpose

This *Activity* provides a rough outline of the creation of an Atomic Software Component.

#### 2.4.1.2 Description

**[TR\_METH\_01060] Develop an Atomic Software Component activity** [ This is the generic *Activity* valid for several kinds of Atomic Software Components. The first step is to create design, including the runnables, events, interrunable variables, etc. Once this is complete, the contract header files can be created and the software component can be implemented. ]([RS\\_METH\\_00002](#), [RS\\_METH\\_00038](#))

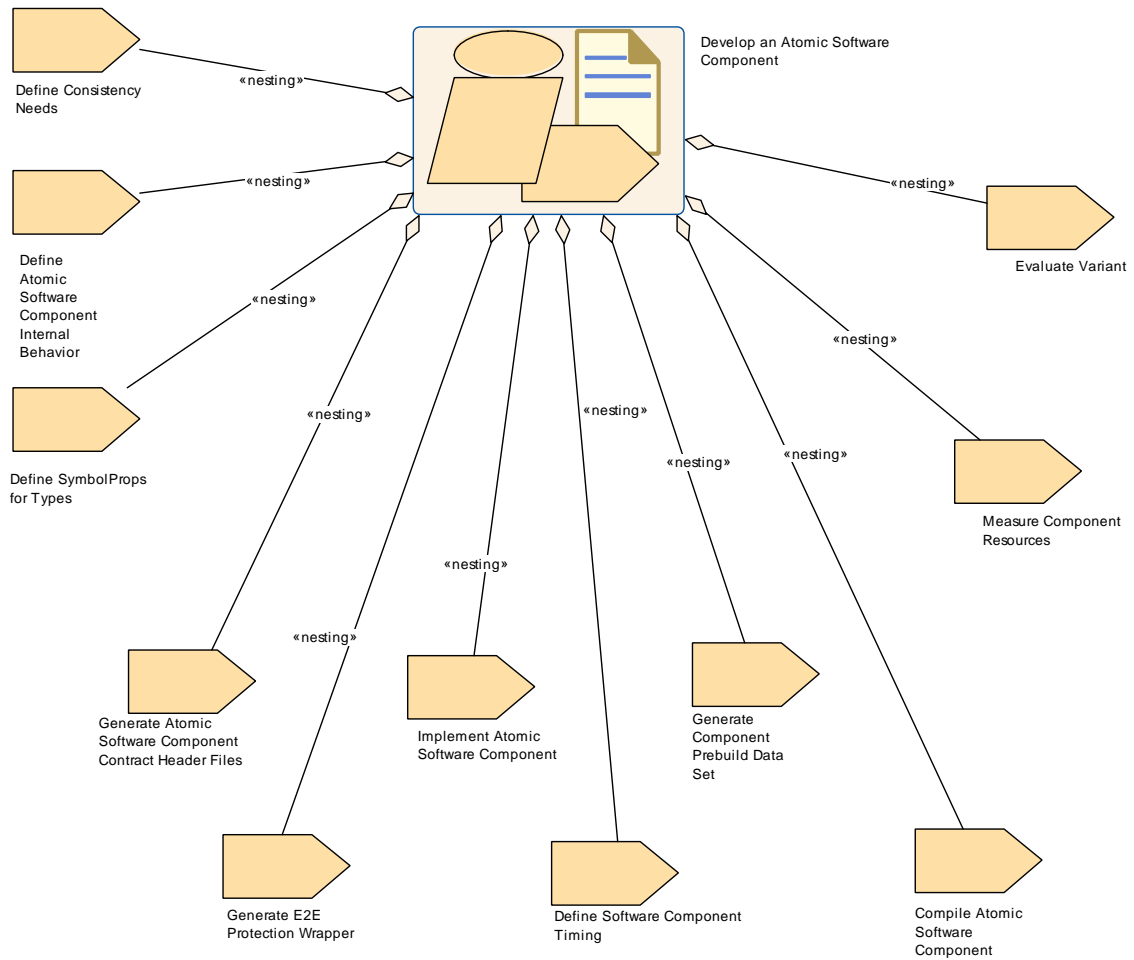
Note that the method of implementation, quality, testing, etc. are beyond the scope of this activity.

After the component is implemented and successfully compiled, its resources are measured and stored as part of the software component description for further usage by downstream processes.

The pattern also includes the optional tasks of creating a timing model, binding pre-build-variants and evaluating variants, all in the scope of the atomic software component. Note that the sequence of these optional tasks within the *Activity* is only one possible example.

#### 2.4.1.3 Workflow

Figure 2.5 shows the work breakdown assumed for this use case. The next two figures 2.6 and 2.7 show all the tasks and work products of the method library involved in this use case.

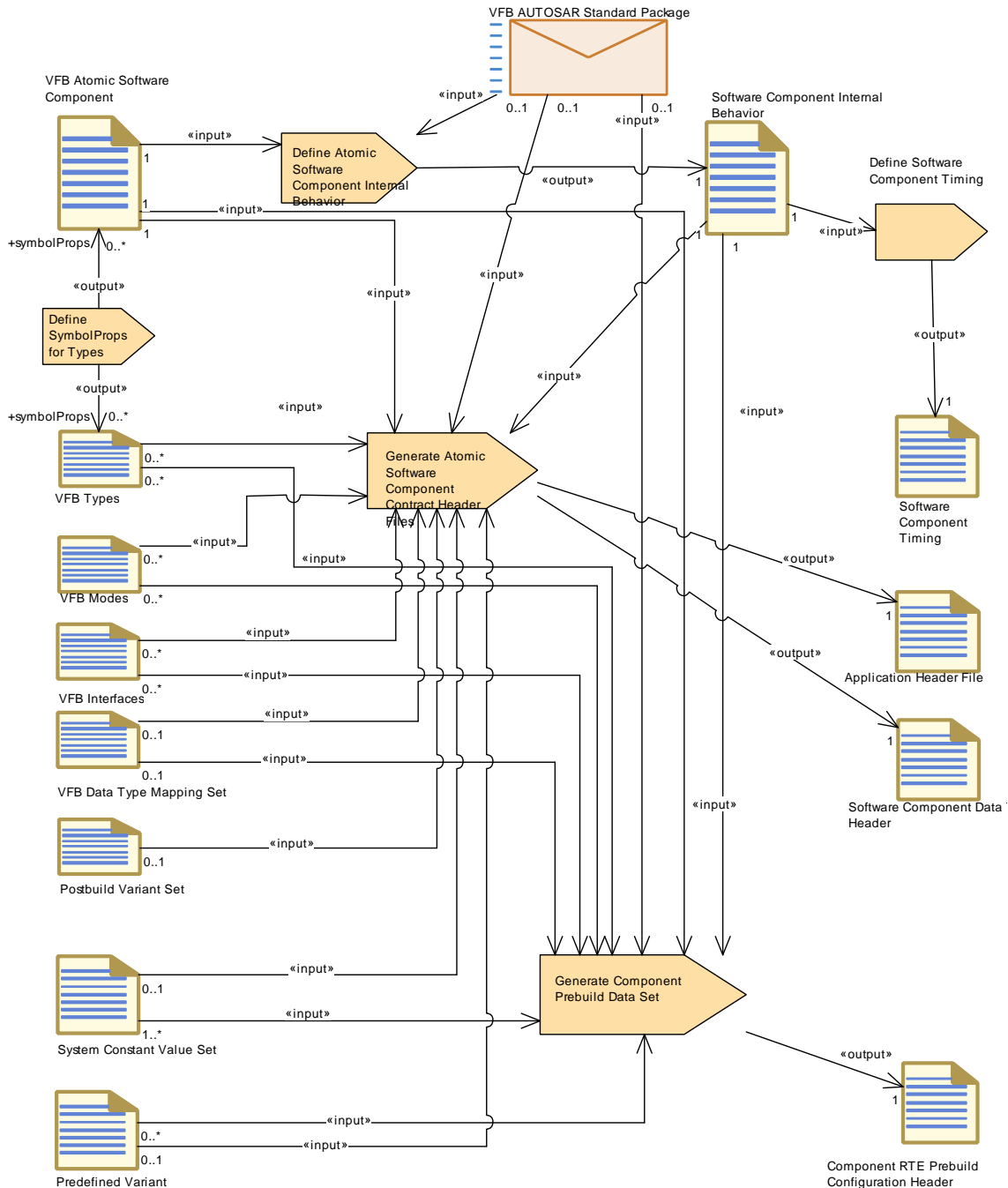


**Figure 2.5: Develop an Atomic Software Component**

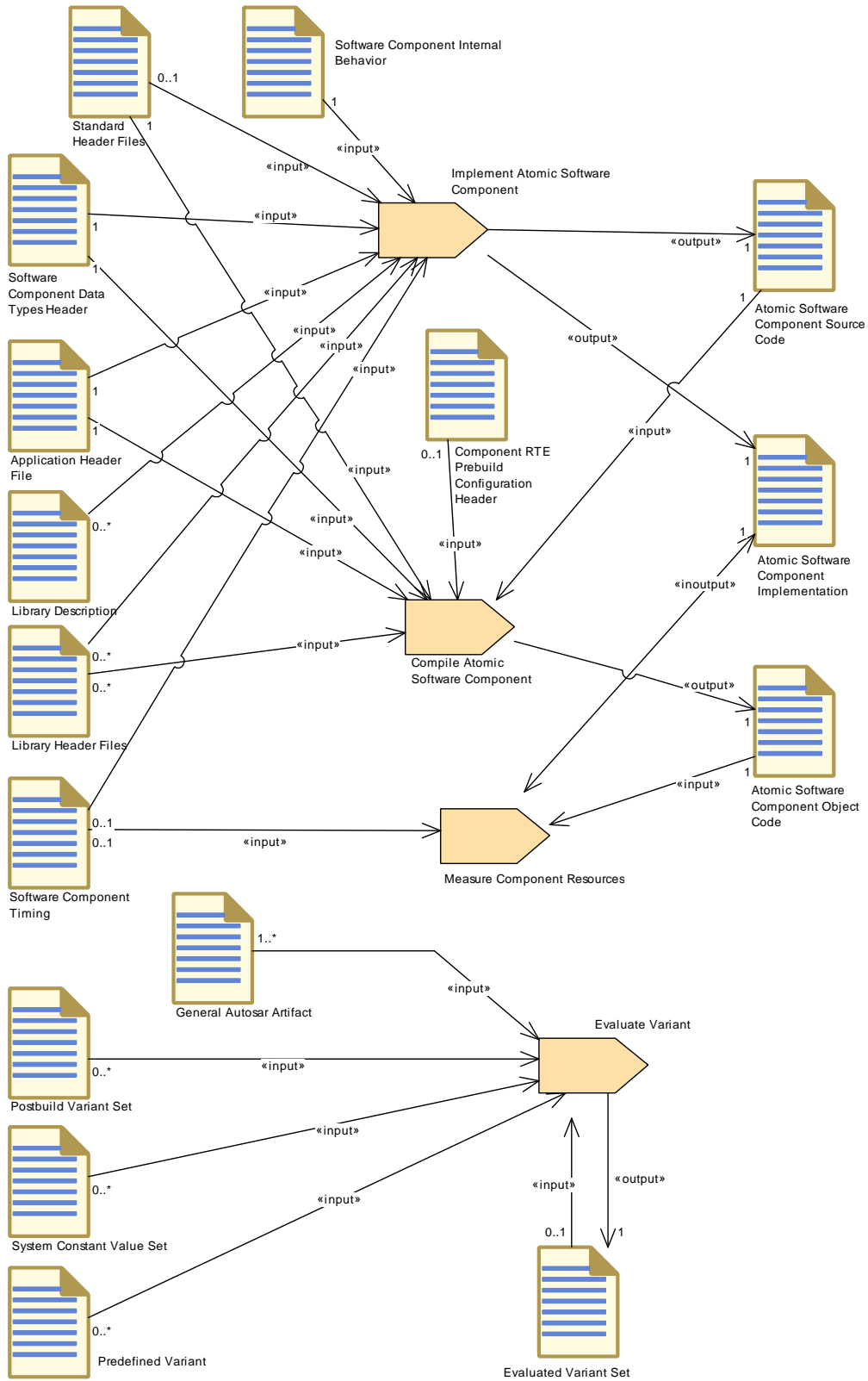
<b>Activity</b>	<b>Develop an Atomic Software Component</b>		
<b>Package</b>	AUTOSAR Root::M2::Methodology::Methodology Use Cases::Software Component::Develop Atomic SWC		
<b>Brief Description</b>			
<b>Description</b>	<p>This is the generic pattern valid for several kinds of Atomic Software Components. The first step is to create design, including the runnables, events, interrunnable variables, etc. Once this is complete, the contract header files can be created and the software component can be implemented.</p> <p>Note that the method of implementation, quality, testing, etc. are beyond the scope of this capability pattern.</p> <p>After the component is implemented and successfully compiled, its resources are measured and stored as part of the software component for further usage by downstream processes.</p> <p>The pattern also includes the optional tasks of creating a timing model, binding prebuild-variants and evaluating variants, all in the scope of the Atomic Software Component. Note that the sequence of these optional tasks within the capability pattern is only one possible example.</p>		
<b>Extended by</b>	<a href="#">Develop Application Software</a> , <a href="#">Develop a Complex Driver Component</a> , <a href="#">Develop a Sensor Actuator Component</a> , <a href="#">Develop an ECU Abstraction Component</a> , <a href="#">Optimize a Software Component for a Specific Target</a>		
<b>Relation Type</b>	<b>Related Element</b>	<b>Mul.</b>	<b>Note</b>
Aggregates	<a href="#">Compile Atomic Software Component</a>	1	
Aggregates	<a href="#">Define Atomic Component Internal Behavior</a>	1	
Aggregates	<a href="#">Define Consistency Needs</a>	1	Used for defining the consistency relations between a group of RunnableEntitys and a group of DataPrototypes.
Aggregates	<a href="#">Define Software Component Timing</a>	1	
Aggregates	<a href="#">Define Symbol Props for Types</a>	1	Used for solving name conflicts on the level of component or data types.
Aggregates	<a href="#">Evaluate Variant</a>	1	
Aggregates	<a href="#">Generate Atomic Component Contract Header Files</a>	1	
Aggregates	<a href="#">Generate Component Prebuild Data Set</a>	1	
Aggregates	<a href="#">Generate E2E Protection Wrapper</a>	1	

Relation Type	Related Element	Mul.	Note
Aggregates	Implement Atomic Software Component	1	
Aggregates	Measure Component Resources	1	

**Table 2.7: Develop an Atomic Software Component**



**Figure 2.6: Develop an Atomic Software Component - Detailed view with work products (1)**



**Figure 2.7: Develop an Atomic Software Component - Detailed view with work products (2)**



## 2.4.2 Develop Application Software

### 2.4.2.1 Purpose

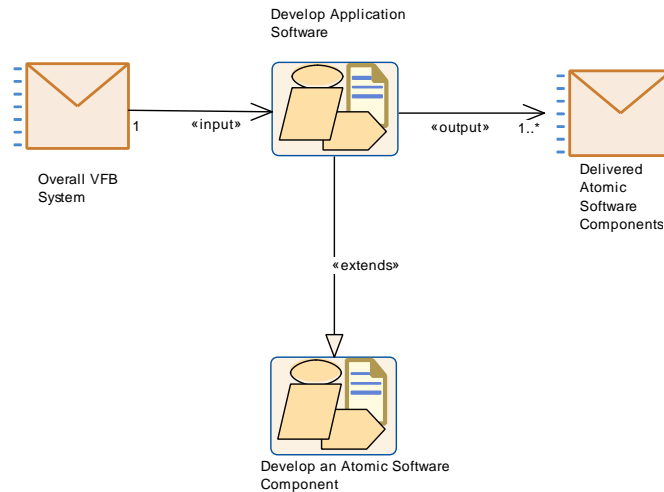
This Activity provides a rough outline of the creation of one or more Application Software Components.

### 2.4.2.2 Description

**[TR\_METH\_01061] Develop Application Software activity** [ This Activity describes the work flow and the necessary activities in terms of the AUTOSAR methodology to develop one or more Application Software Components. The work flow shall allow a more or less independent development of the software components core functionality. These activities have to be performed for each Application Software Component. ](RS\_METH\_00002, RS\_METH\_00006)

### 2.4.2.3 Workflow

The detailed work flow can be derived from the generic activity [Develop an Atomic Software Component](#).



**Figure 2.8: Develop Application Software**

<b>Activity</b>	<b>Develop Application Software</b>		
<b>Package</b>	AUTOSAR Root::M2::Methodology::Methodology Use Cases::Software Component::Develop Application SWC		
<b>Brief Description</b>			
<b>Description</b>	<p>This pattern describes the workflow and the necessary activities in terms of the AUTOSAR methodology for the development of application software components.</p> <p>The workflow shall allow a more or less independent development of the software component core functionality. These activities have to be performed for every application software component.</p>		
<b>Extends</b>	<a href="#">Develop an Atomic Software Component</a>		
<b>Relation Type</b>	<b>Related Element</b>	<b>Mul.</b>	<b>Note</b>
Consumes	<a href="#">Overall VFB System</a>	1	The application software needs to refer to the relevant elements of the overall VFB system such as Software Component Types, Port Interfaces and Data Types.
Produces	<a href="#">Delivered Atomic Software Components</a>	1..*	

**Table 2.8: Develop Application Software**

## 2.4.3 Uses Cases for more Specialized Software Components

### 2.4.3.1 Purpose

These *Activities* provides a rough outline of the creation of more specialized components and of the ECU specific optimization of a software component.

### 2.4.3.2 Description

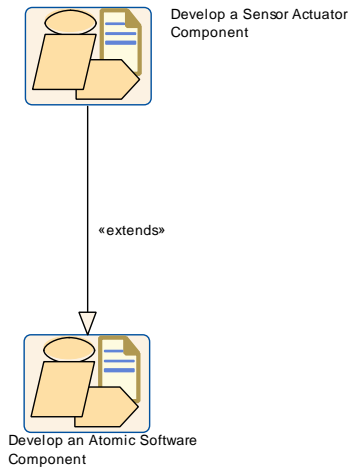
These *Activities* describe the work flow and the necessary activities in terms of the AUTOSAR methodology to develop more specialized components, which could be partially hardware or ECU dependent.

### 2.4.3.3 Workflow

These work flows can for the most part derived from the generic activity [Develop an Atomic Software Component](#). The diagrams show the required extensions.

Note the development of a Service Component does not fall into this category of use cases, because it is for the most part generated during integration time.

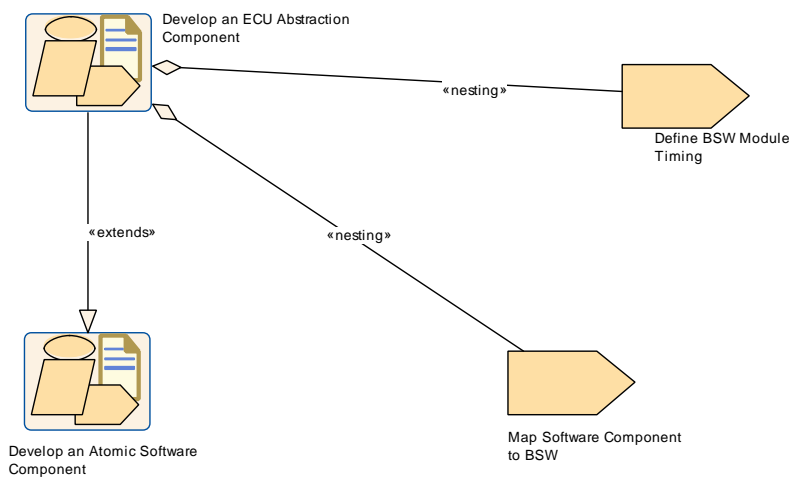
For the development of a [VFB Parameter Component](#) refer to the calibration use case [2.9](#).



**Figure 2.9: Develop a Sensor or Actuator Component**

<b>Activity</b>	<b>Develop a Sensor Actuator Component</b>		
<b>Package</b>	AUTOSAR Root::M2::Methodology::Methodology Use Cases::Software Component::Develop Sensor-Actuator Component		
<b>Brief Description</b>	Show how to develop a Sensor Actuator Component		
<b>Description</b>	Activities to develop a VFB Sensor Actuator Component, i.e. component that represents a physical sensor or actuator.		
<b>Extends</b>	<a href="#">Develop an Atomic Software Component</a>		
<b>Relation Type</b>	<b>Related Element</b>	<b>Mul.</b>	<b>Note</b>

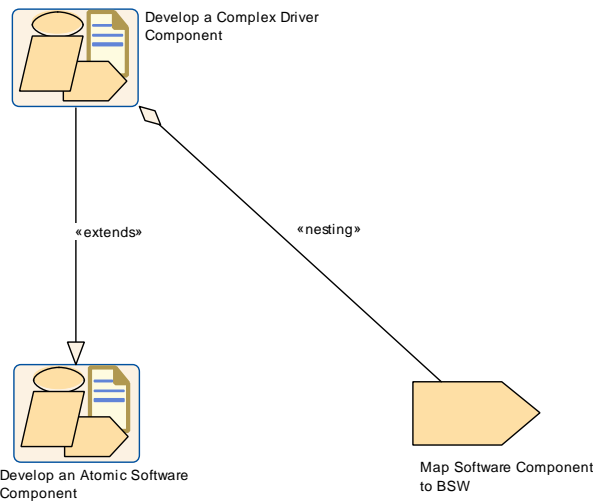
**Table 2.9: Develop a Sensor Actuator Component**



**Figure 2.10: Develop an ECU Abstraction Component**

<b>Activity</b>	<b>Develop an ECU Abstraction Component</b>		
<b>Package</b>	AUTOSAR Root::M2::Methodology::Methodology Use Cases::Software Component::Develop Ecuabs Component		
<b>Brief Description</b>	Show how to develop an ECU Abstraction Component.		
<b>Description</b>	Activities to develop an ECU Abstraction Software Component, i.e. a component that implements an ECU Abstraction..		
<b>Extends</b>	<a href="#">Develop an Atomic Software Component</a>		
<b>Relation Type</b>	<b>Related Element</b>	<b>Mul.</b>	<b>Note</b>
Aggregates	<a href="#">Define BSW Module Timing</a>	1	
Aggregates	<a href="#">Map Software Component to BSW</a>	1	

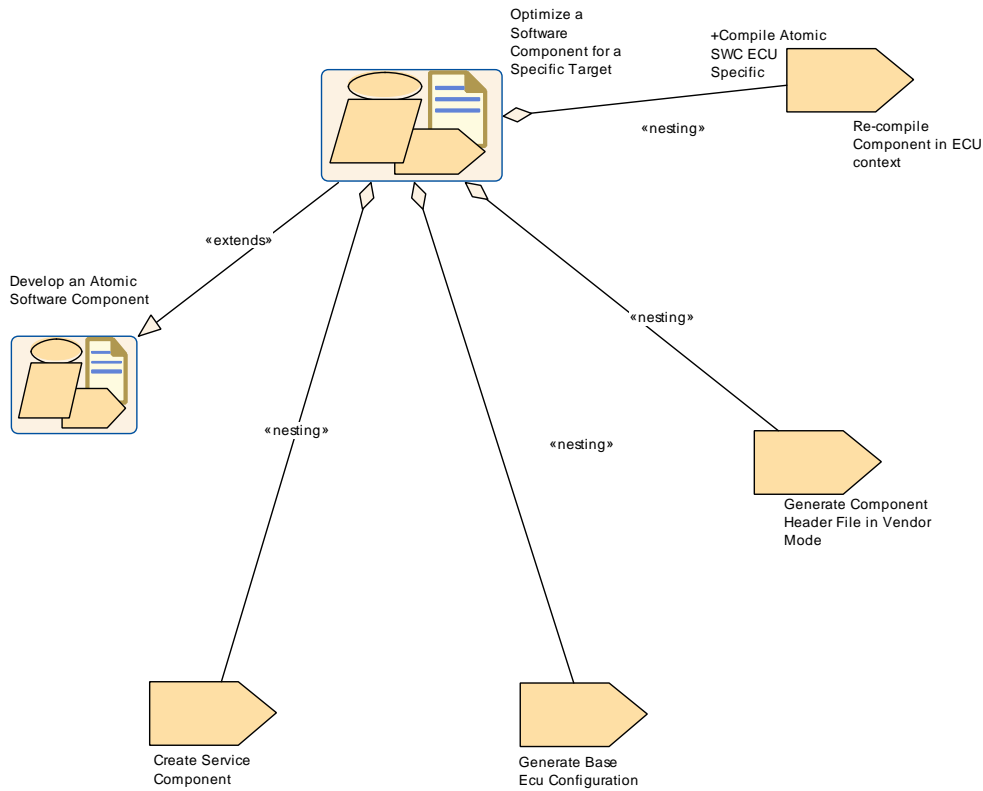
**Table 2.10: Develop an ECU Abstraction Component**



**Figure 2.11: Develop a Complex Driver Component**

<b>Activity</b>	<b>Develop a Complex Driver Component</b>		
<b>Package</b>	AUTOSAR Root::M2::Methodology::Methodology Use Cases::Software Component::Develop CDD Component		
<b>Brief Description</b>	Show how to develop a Complex Driver Component		
<b>Description</b>	Show how to develop a Complex Driver Component		
<b>Extends</b>	<a href="#">Develop an Atomic Software Component</a>		
<b>Relation Type</b>	<b>Related Element</b>	<b>Mul.</b>	<b>Note</b>
Aggregates	<a href="#">Map Software Component to BSW</a>	1	

**Table 2.11: Develop a Complex Driver Component**



**Figure 2.12: Optimize Software Component**

<b>Activity</b>	<b>Optimize a Software Component for a Specific Target</b>		
<b>Package</b>	AUTOSAR Root::M2::Methodology::Methodology Use Cases::Software Component::Optimize Software Component		
<b>Brief Description</b>	Show how to optimize a software component for a specific target.		
<b>Description</b>	<p>In practice the integration of an application software component has to consider some optimizations to meet performance or resource requirements. The Component API might be much more efficient, if it will be generated particularly adapted to the concrete ECU configuration, e.g. via using macro definitions instead of function calls for some RTE interaction. In fact this should not change the Component Implementation (i.e. the C-sources).</p> <p>That means now we have a different set of component headers, which include the ECU-configuration-specific optimizations.</p> <p>Note: This use case shows the typical steps needed until the recompilation with the optimized header file can be done. It does not show all the other steps needed for the ECU build.</p>		
<b>Extends</b>	<a href="#">Develop an Atomic Software Component</a>		
<b>Relation Type</b>	<b>Related Element</b>	<b>Mul.</b>	<b>Note</b>
Aggregates	<a href="#">Create Service Component</a>	1	
Aggregates	<a href="#">Generate Base Ecu Configuration</a>	1	

<i>Relation Type</i>	<i>Related Element</i>	<i>Mul.</i>	<i>Note</i>
Aggregates	Generate Component Header File in Vendor Mode	1	
Aggregates	Re-compile Component in ECU context	1	Compile Atomic SWC ECU Specific:

**Table 2.12: Optimize a Software Component for a Specific Target**

## 2.5 Develop System and Subsystems

### 2.5.1 Overview

#### 2.5.1.1 Purpose

The `Activities` to develop the artifacts on the system level include the optional development of the abstract system (see Chapter 2.2), the development of an overall (technical) system and optionally the refinement into one or more subsystems. The reason for this split is, that the latter may be done by another organization, as has already been pointed out in 2.1.2.

#### 2.5.1.2 Description

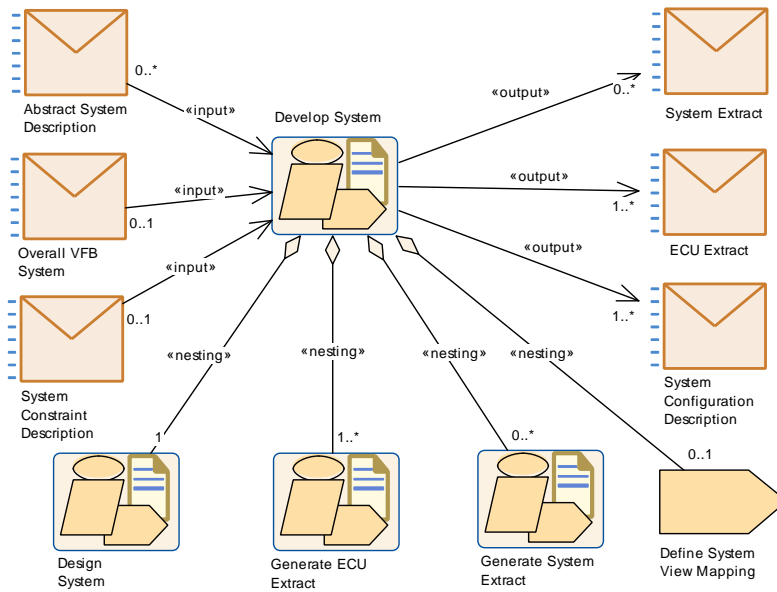
[TR\_METH\_01065] **Develop System and Develop Sub-System activities** [ Figures 2.13 and 2.14 show the main inputs and outputs of these two major activities and how they are refined into sub-activities. Note that the activity `Generate ECU Extract` can be performed as part of `Develop System` and `Develop Sub-System` as well. Optionally a mapping between two different system views representing by different `System Descriptions` can be added (see Section 3.3.1.15). ](*RS\_METH\_00005, RS\_METH\_00002*)

[TR\_METH\_01066] **Creation of a System Extract and an ECU Extract** [ Depending on the intended work split, the `System Configuration Description` produced during this activity can be used as a basis

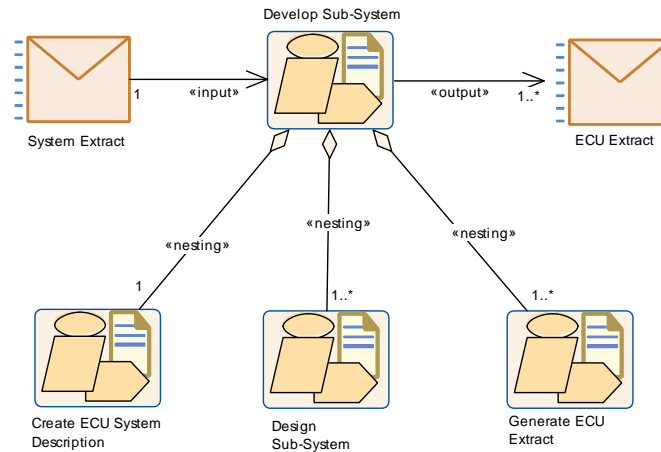
1. to create one or more so-called `System Extracts` as a basis for further refinement as sub-systems (see 2.5.5)
2. or to generate `ECU Extracts` which directly contain all relevant information to be integrated on an ECU (see 2.5.6)

In the first case, only an `outer system` is defined. Based on the `outer system`, one or more `System Extracts` can be delivered. The `System Extract` is not fully decomposed and still needs to be refined before it forms the basis for the ECU configuration. In order to distinguish between the delivered `System Ex-`

tracts and the refined sub-system, one or more **ECU System Descriptions** are created as a basis for further refinement (See activity **Create ECU System Description**). Atomic Software Components, additional ECUs, Networks and the resulting communication will be added during the refinement step in the activity **Design Sub-System.** *(RS\_METH\_00005, RS\_METH\_00002)*



**Figure 2.13: Structure of Activity: Develop System**

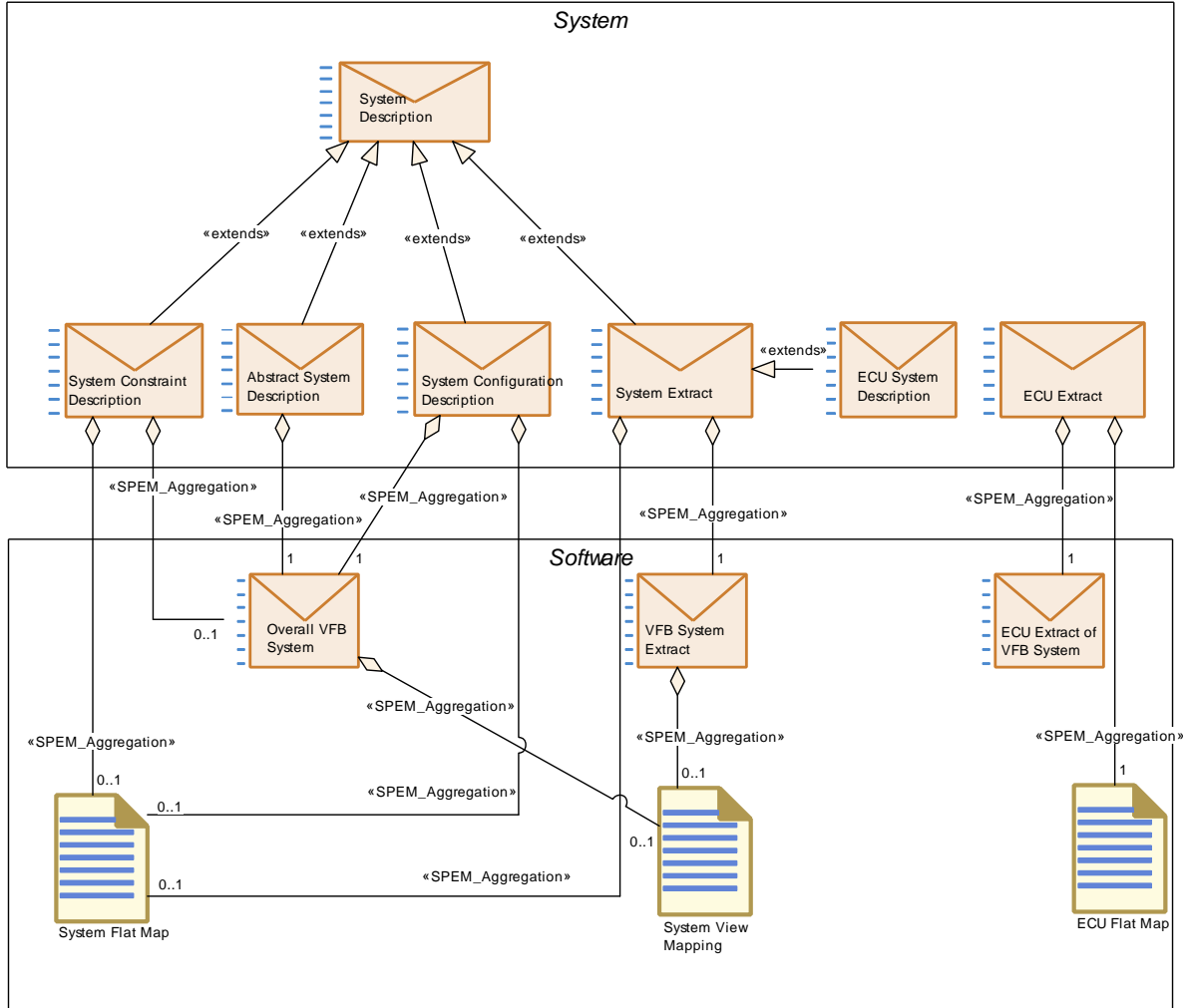


**Figure 2.14: Structure of Activity: Develop Subsystem**

Figure 2.15 shows how the major deliverables produced during these activities are related and how they refer to artifacts describing the software.

**[TR\_METH\_01067] Abstract System Description deliverable** [ The **Abstract System Description** extends the general **System Description**. The **System View Mapping** maps the different views on the system together, e.g. different overall VFB systems (e.g. **Abstract System Description** with **System**

Configuration Description), or the overall VFB system with the VFB System Extract description. |(RS METH 00005, RS METH 00002)



**Figure 2.15: Overview on the different roles of deliverables based on System Description**

Note that all the deliverables based on the generic deliverable System Description as well as the ECU Extract consist of ARXML files that are using the meta-model element System as the root element, from where the other information can be traced down.

<b>Activity</b>	<b>Develop System</b>		
<b>Package</b>	AUTOSAR Root::M2::Methodology::Methodology Use Cases::System::Develop System		
<b>Brief Description</b>			
<b>Description</b>	Develop the description of an overall AUTOSAR System as a basis to deliver System and/or ECU extracts.		
<b>Relation Type</b>	<b>Related Element</b>	<b>Mul.</b>	<b>Note</b>



<i>Relation Type</i>	<i>Related Element</i>	<i>Mul.</i>	<i>Note</i>
Consumes	<a href="#">Abstract System Description</a>	0..*	The abstract System Description is an optional input for the activity "Develop System". Please note, that in this step the Abstract System Description is refined to a System Description.
Consumes	<a href="#">Overall VFB System</a>	0..1	Usually the System refers to elements of an overall VFB descriptions. But for the description of a legacy system, this input might be empty.
Consumes	<a href="#">System Constraint Description</a>	0..1	
Produces	<a href="#">ECU Extract</a>	1..*	
Produces	<a href="#">System Configuration Description</a>	1..*	
Produces	<a href="#">System Extract</a>	0..*	
Aggregates	<a href="#">Define System View Mapping</a>	0..1	
Aggregates	<a href="#">Design System</a>	1	
Aggregates	<a href="#">Generate ECU Extract</a>	1..*	
Aggregates	<a href="#">Generate System Extract</a>	0..*	

**Table 2.13: Develop System**

<i>Activity</i>	<b>Develop Sub-System</b>		
<b>Package</b>	AUTOSAR Root::M2::Methodology::Methodology Use Cases::System::Develop System		
<b>Brief Description</b>			
<b>Description</b>	Develop the description of a sub-system based on a given System Extract.		
<i>Relation Type</i>	<i>Related Element</i>	<i>Mul.</i>	<i>Note</i>
Consumes	<a href="#">System Extract</a>	1	
Produces	<a href="#">ECU Extract</a>	1..*	
Aggregates	<a href="#">Create ECU System Description</a>	1	
Aggregates	<a href="#">Design Sub-System</a>	1..*	
Aggregates	<a href="#">Generate ECU Extract</a>	1..*	

**Table 2.14: Develop Sub-System**

## 2.5.2 Design System

### 2.5.2.1 Purpose

This `Activity` provides a rough outline of the design steps leading to an AUTOSAR `System Configuration Description` and the system-specific part of the `Abstract System Description`, including its topology, deployment, communication matrix, etc.

### 2.5.2.2 Description

**[TR\_METH\_01068] Inputs and Output of the `Design System` activity** [ The design of an AUTOSAR `System Configuration Description` and the system-specific part of the `Abstract System Description` uses input information from a `System Constraint Description` and is based on an `Overall VFB System` for the software part. Optionally, the `Abstract System Description` that represents the functional view on the system can be used as an input. Please note that the inputs and output are depicted in the top-level activities which aggregates the activity `Design System`.

The activity involves the creation of a `Topology`, `ECU Resources Descriptions`, and the interconnection between ECU instances. ]([RS\\_METH\\_00005](#), [RS\\_METH\\_00002](#), [RS\\_METH\\_00078](#), [RS\\_METH\\_00079](#))

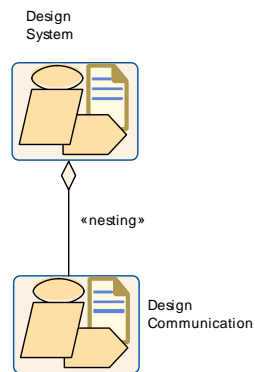
**[TR\_METH\_01069] Deployment of AUTOSAR Software Components** [ The AUTOSAR Software Components defined within the `VFB Top Level System Composition` are then deployed to the ECU instances. ]

**[TR\_METH\_01070] Description of network signals** [ The required network signals are identified and a mapping is done to `System Signals` to implement the VFB. `System Signal Groups`, are defined to keep certain signals grouped together for consistent transmission. `System Signals` are then defined and form the initial input to design the `Communication`. ]([RS\\_METH\\_00005](#))

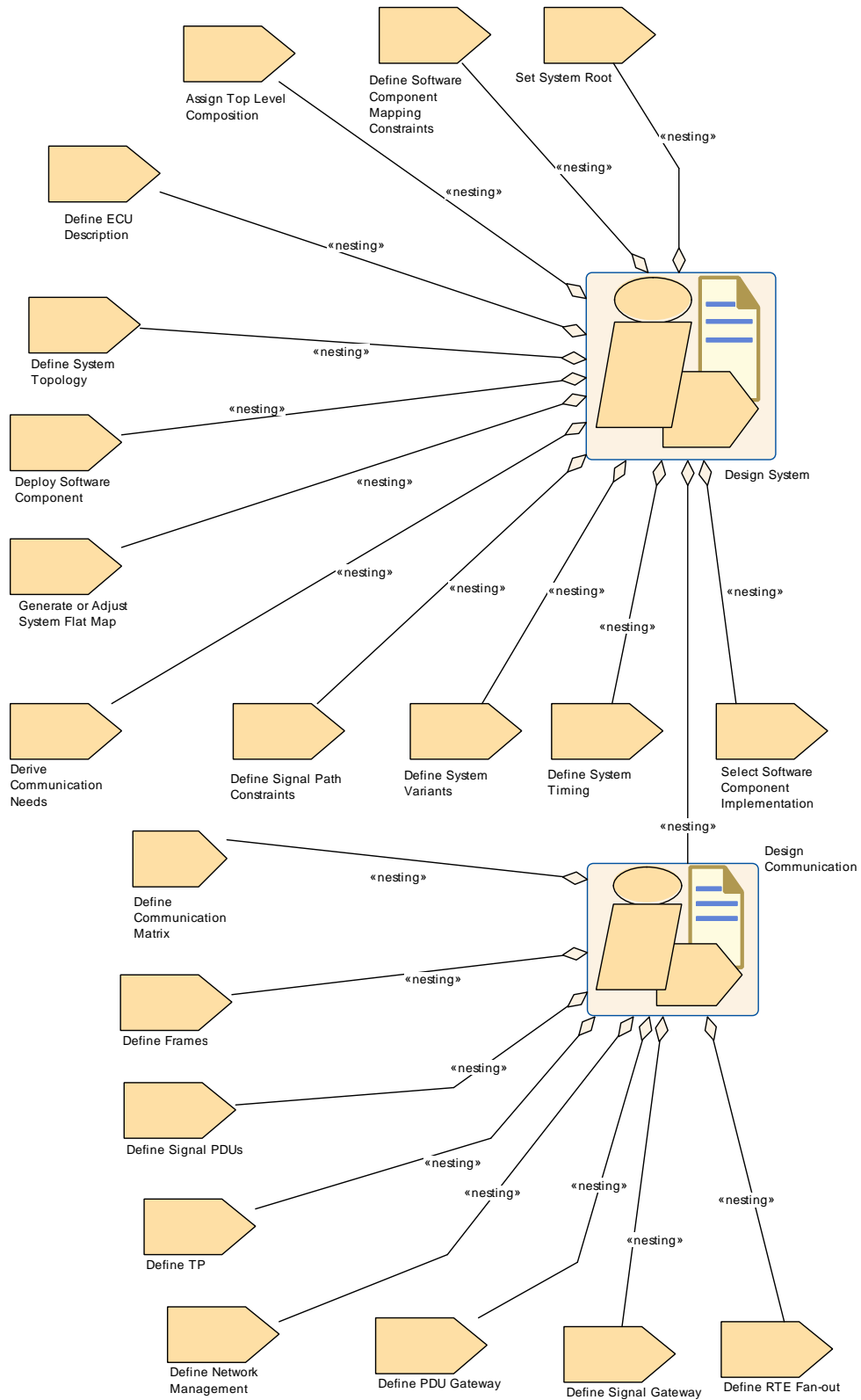
**[TR\_METH\_01071] Description of design constraints** [ During this stage, design constraints can also be defined `Mapping of Software Components to Implementations`, `Mapping of Software Components to ECUs`, `Signal Path Constraints`, and `Software Component Mapping Constraints`. These constraints serve many purposes including the ability for tools to use them to optimization a system, to interface with legacy ECUs, and to "lock" design decision between iterations. ]([RS\\_METH\\_00005](#), [RS\\_METH\\_00002](#), [RS\\_METH\\_00041](#), [RS\\_METH\\_00020](#))

Note: The mapping of software components to implementations is optional and needed only if those components are specifically required to be used in an ECU.

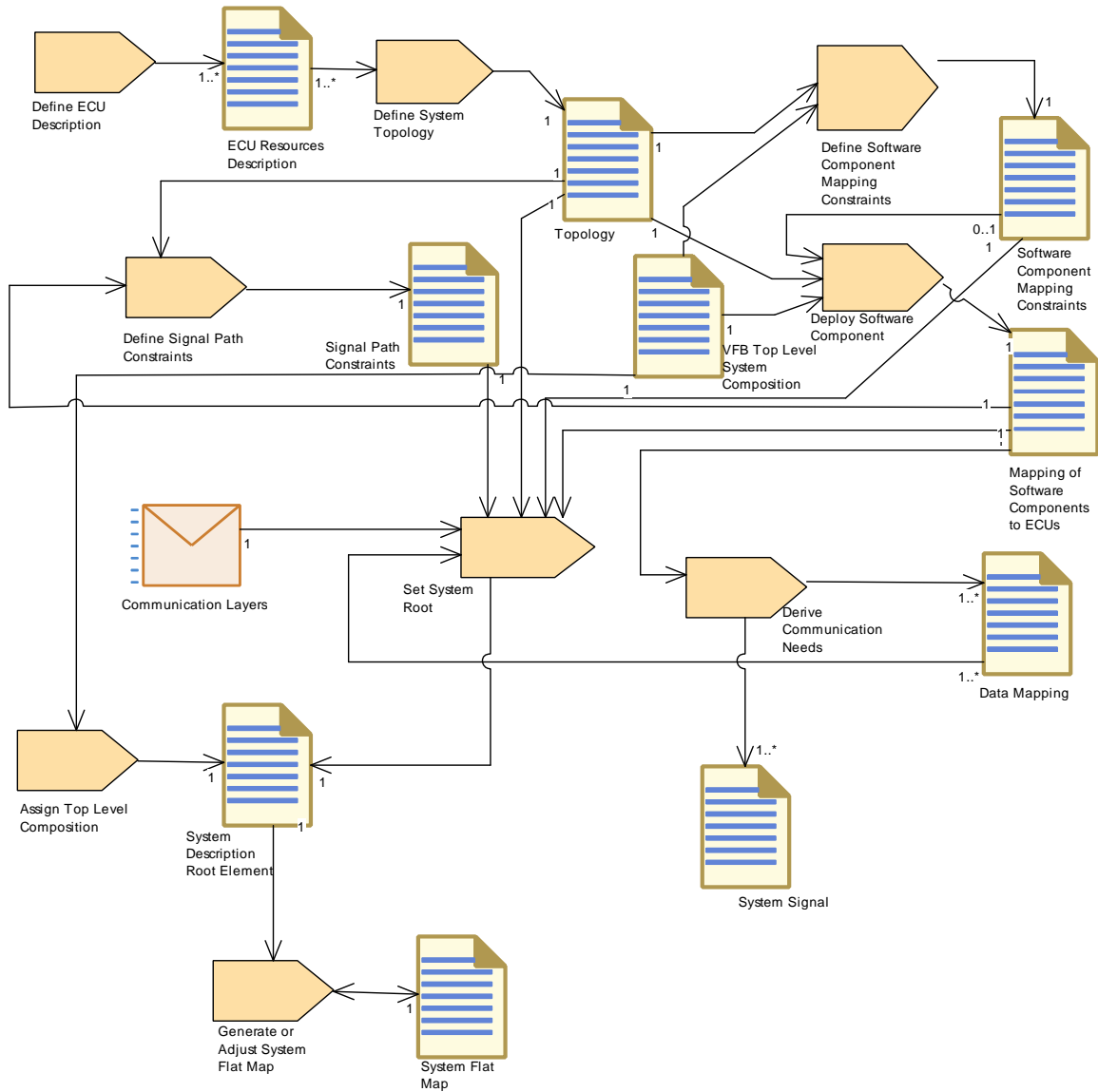
### 2.5.2.3 Workflow



**Figure 2.16: Structure overview: Design System**



**Figure 2.17: Nesting relationship: Design System**



**Figure 2.18: Detailed work flow for: Design System**

<b>Activity</b>	<b>Design System</b>		
<b>Package</b>	AUTOSAR Root::M2::Methodology::Methodology Use Cases::System::Design System		
<b>Brief Description</b>	Initial work to create a topology, map a VFB onto that topology and determine the ECU resources each ECU needs.		
<b>Description</b>	<p>The design of an AUTOSAR System involves the creation of a Topology, ECU Resources Descriptions, and the interconnection between ECU instances.</p> <p>The software components defined within the VFB Top Level System Composition are then deployed to the ECU instances.</p> <p>The required network signals are identified and a mapping is done to System Signals to implement the VFB. System Signal Groups, are defined to keep certain signals grouped together for atomic transmission. System Signals are then defined and form the initial input to design the Communication Matrix.</p> <p>During this stage, design constraints can also be defined (Mapping of Software Components to Implementations, Mapping of Software Components to ECUs, Signal Path Constraint, and Software Component Mapping Constraint ). These constraints serve many purposes including the ability for tools to use them to optimization a system, to interface with legacy ECUs, and to "lock" design decision between iterations.</p> <p>Notes: The mapping of software components to implementations is optional and needed only if those components are specifically required to be used in an ECU.</p>		
<b>Relation Type</b>	<b>Related Element</b>	<b>Mul.</b>	<b>Note</b>
Aggregates	<a href="#">Assign Top Level Composition</a>	1	
Aggregates	<a href="#">Define ECU Description</a>	1	
Aggregates	<a href="#">Define Signal Path Constraints</a>	1	
Aggregates	<a href="#">Define Software Component Mapping Constraints</a>	1	
Aggregates	<a href="#">Define System Timing</a>	1	
Aggregates	<a href="#">Define System Topology</a>	1	
Aggregates	<a href="#">Define System Variants</a>	1	
Aggregates	<a href="#">Deploy Software Component</a>	1	
Aggregates	<a href="#">Derive Communication Needs</a>	1	
Aggregates	<a href="#">Design Communication</a>	1	

<i>Relation Type</i>	<i>Related Element</i>	<i>Mul.</i>	<i>Note</i>
Aggregates	<a href="#">Generate or Adjust System Flat Map</a>	1	
Aggregates	<a href="#">Select Software Component Implementation</a>	1	
Aggregates	<a href="#">Set System Root</a>	1	

**Table 2.15: Design System**

<i>Activity</i>	<i>Design Communication</i>		
<i>Package</i>	AUTOSAR Root::M2::Methodology::Methodology Use Cases::System::Design System		
<i>Brief Description</i>			
<i>Description</i>	<p>Describe all communication layers. and define the mapping of the triggering elements within the Physical Channels to the communication connector ports for the individual ECUs.</p> <p>Because the triggering elements are aggregated as splittable elements within the Physical Channels it is possible to define them in an artifact separated from the Topology.</p>		
<i>Relation Type</i>	<i>Related Element</i>	<i>Mul.</i>	<i>Note</i>
Aggregates	<a href="#">Define Communication Matrix</a>	1	
Aggregates	<a href="#">Define Frames</a>	1	
Aggregates	<a href="#">Define Network Management</a>	1	
Aggregates	<a href="#">Define PDU Gateway</a>	1	
Aggregates	<a href="#">Define RTE Fan-out</a>	1	
Aggregates	<a href="#">Define Signal Gateway</a>	1	
Aggregates	<a href="#">Define Signal PDUs</a>	1	
Aggregates	<a href="#">Define TP</a>	1	

**Table 2.16: Design Communication**

## 2.5.3 Generate System Extract

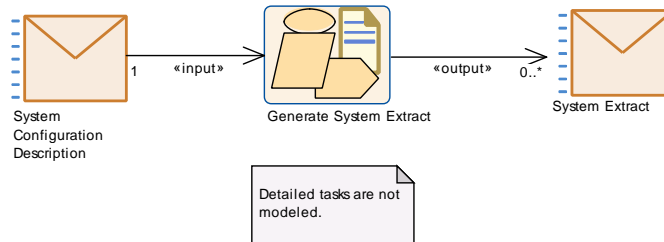
### 2.5.3.1 Purpose

This `Activity` provides an extract of the system description for a specific sub-system.

### 2.5.3.2 Description

Generate a [System Extract](#) which is a basis to develop a sub-system.

### 2.5.3.3 Workflow



**Figure 2.19: Generate the System Extract**

The detailed tasks of [Generate System Extract](#) are not modeled since they are considered as trivial - it just means to reduce the content of the input description to the subsystem in question.

<b>Activity</b>	<b>Generate System Extract</b>		
<b>Package</b>	AUTOSAR Root::M2::Methodology::Methodology Use Cases::System::Generate System Extract		
<b>Brief Description</b>			
<b>Description</b>	Generate for further development, a System Extract which represents the description of a part of the system (sub-system). This allows a start of work on ECU's even if the system is not completely described.		
<b>Relation Type</b>	<b>Related Element</b>	<b>Mul.</b>	<b>Note</b>
Consumes	<a href="#">System Configuration Description</a>	1	
Produces	<a href="#">System Extract</a>	0..*	

**Table 2.17: Generate System Extract**

## 2.5.4 Create ECU System Description

### 2.5.4.1 Purpose

Based on a [System Extract](#), this Activity creates [ECU System Descriptions](#) which are refined during the design of the sub-system.

### 2.5.4.2 Description

[TR\_METH\_01125] [Create ECU System Description activity](#) [ Based on the delivered [System Extract](#), the receiving organization creates one or more ECU De-



scriptions. The ECU Descriptions are used for designing the sub-system artifacts (See activity *Design Sub-System*). |(RS\_METH\_00002, RS\_METH\_00005, RS\_METH\_00077)

From the methodological point of view there are two choices for creating the ECU System Description.

**[TR\_METH\_01126] Using the System Extract as the structural basis for the ECU development** [ The System Extract is taken as the structural basis for the ECU development. In this case the System Extract becomes an ECU System Description. |(RS\_METH\_00002, RS\_METH\_00005, RS\_METH\_00077)

**[TR\_METH\_01127] Creating a new structure for the ECU development** [ A new structure is created as a basis for the ECU development. The newly created ECU System Description is mapped to the initial System Extract. For this purpose the task Define System View Mapping creates the initial System View Mapping artifact which is refined during the sub-system design. |(RS\_METH\_00002, RS\_METH\_00005, RS\_METH\_00077)

### 2.5.4.3 Workflow

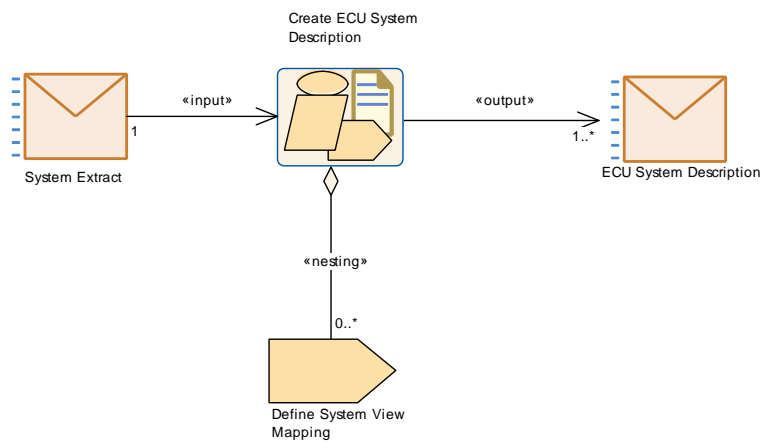


Figure 2.20: Create ECU System Description

<b>Activity</b>	<b>Create ECU System Description</b>		
<b>Package</b>	AUTOSAR Root::M2::Methodology::Methodology Use Cases::System::Create ECU System Description		
<b>Brief Description</b>			
<b>Description</b>	<p>During the Develop Sub-System activity the supplier refines the received System Extract so that valid ECU Extracts can be generated. The refinement of the System Extract is done using the ECU System Description. Therefore, this activity creates one or more ECU System Descriptions based on the System Extract. The sub-system artifacts are designed in the ECU System Description during the activity "Design Sub-System".</p> <p>From the methodological point of view there are two choices for creating the ECU System Description.</p> <p>1) The System Extract is taken as the structural basis for the ECU development. In this case the System Extract becomes an ECU System Description.</p> <p>2) A new structure is created as a basis for the ECU development. The newly created ECU System Description is mapped to the initial System Extract. For this purpose the task "Define System View Mapping" is performed.</p>		
<b>Relation Type</b>	<b>Related Element</b>	<b>Mul.</b>	<b>Note</b>
Consumes	<a href="#">System Extract</a>	1	
Produces	<a href="#">ECU System Description</a>	1..*	
Aggregates	<a href="#">Define System View Mapping</a>	0..*	

**Table 2.18: Create ECU System Description**

## 2.5.5 Design Sub-System

### 2.5.5.1 Purpose

This `Activity` details a given `ECU System Description` (previously created from the delivered `System Extract`) with additional ECUs and networks.

### 2.5.5.2 Description

**[TR\_METH\_01075] Design Sub-System activity** [ Based on the `ECU System Description`, the description of a sub-system is defined. ]([RS\\_METH\\_00002](#), [RS\\_METH\\_00005](#))

**[TR\_METH\_01076] Collaboration between different organizations** [ Additionally, the software component structure of the `System Extracts`, delivered by the primary organization can be transformed into a different structure by the receiving organization

([ECU System Description](#)). In this case the [System Extract](#) of the primary organization can be considered as a requirement and the sub-system of the receiving organization can be seen as a solution which has to fulfill the delivered requirements. Thus here again a mapping activity can be defined which maps the newly introduced solution sub-system to the provided requirement sub-system from the primary organization. ]([RS\\_METH\\_00002](#), [RS\\_METH\\_00005](#), [RS\\_METH\\_00077](#))

**[TR\_METH\_01077] Transformation changes during the [Design Sub-System activity](#)** [ During this transformation the hierarchical SWC-structure can be changed, some SWCs can be replaced by other SWCs, some can remain in the resulting view. ]([RS\\_METH\\_00002](#), [RS\\_METH\\_00005](#))

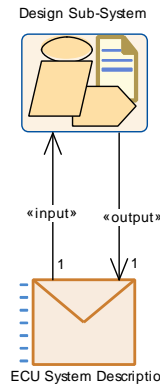
**[TR\_METH\_01078] Mapping of different views** [ The different views are mapped by the [System View Mapping](#). ]([RS\\_METH\\_00002](#), [RS\\_METH\\_00005](#))

Typical use-cases for this transformation steps are:

- **[TR\_METH\_01079] Use Case: Substitution of existing components** [ The secondary organization has an existing software architecture. By software sharing some of the existing components are substituted by the delivered software components. ]([RS\\_METH\\_00002](#), [RS\\_METH\\_00005](#), [RS\\_METH\\_00077](#), [RS\\_METH\\_00079](#))
- **[TR\_METH\_01080] Use Case: Mapping of requirements to the solution** [ The secondary organization develops one ECU for different primary organizations and therefore has to map the requirements of different primary organizations to its solution. ]([RS\\_METH\\_00002](#), [RS\\_METH\\_00005](#), [RS\\_METH\\_00077](#), [RS\\_METH\\_00079](#))
- **[TR\_METH\_01081] Use Case: Reorganization of the software structure** [ The primary organization delivers a sub-system description which defines one ECU. The secondary organization decides to use two ECUs. Therefore the software structure has to be reorganized by the second organization. ]([RS\\_METH\\_00002](#), [RS\\_METH\\_00005](#), [RS\\_METH\\_00077](#), [RS\\_METH\\_00079](#))
- **[TR\_METH\_01082] Use Case: Description of changes between different versions of [System Descriptions](#)** [ Additionally the mapping can be used to formally describe changes between different versions of [System Descriptions](#). ]([RS\\_METH\\_00002](#), [RS\\_METH\\_00005](#), [RS\\_METH\\_00077](#), [RS\\_METH\\_00079](#))

Finally all [Atomic Software Components](#) in the resulting sub-system scope are included in this sub-system description.

**2.5.5.3 Workflow**



**Figure 2.21: Overview: Design Sub-System**

Note that the [ECU System Description](#) appears as input and output of this Activity because it is refined.

As the detailed work flow for this Activity uses the same elements from the methodology library as the one described in [2.5.2.3](#), the breakdown into tasks is not modeled here.

<b>Activity</b>	<b>Design Sub-System</b>		
<b>Package</b>	AUTOSAR Root::M2::Methodology::Methodology Use Cases::System::Design Sub-System		
<b>Brief Description</b>			
<b>Description</b>	<p>Design the sub-system artifacts based on an ECU System Description which was previously created from the delivered ECU Extract. It consists of the same tasks as the activity Design System.</p> <p>The description must be completed down to the ECU level, so that valid ECU extracts can be generated.</p>		
<b>Relation Type</b>	<b>Related Element</b>	<b>Mul.</b>	<b>Note</b>
Consumes	<a href="#">ECU System Description</a>	1	System Extract as generated from the outer system.
Produces	<a href="#">ECU System Description</a>	1	System Extract refined during design of the corresponding sub-system with elements needed to generate ECU Extract(s).

**Table 2.19: Design Sub-System**

**2.5.6 Generate ECU Extract**

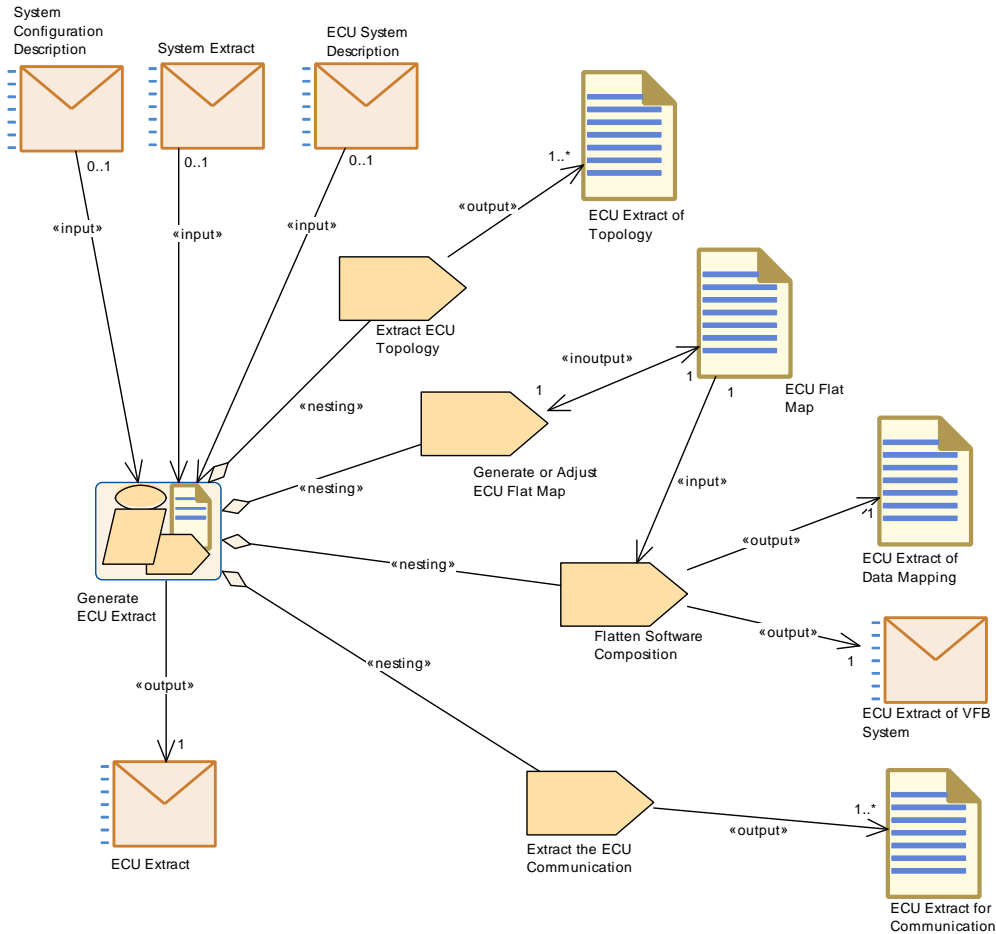
**2.5.6.1 Purpose**

This *Activity* provides an extract of the System description for setting up an ECU Configuration for specific ECU.

### 2.5.6.2 Description

Generate an **ECU Extract** basis for setting up the ECU configuration and further development on ECU level.

### 2.5.6.3 Workflow



**Figure 2.22: Generate the ECU Extract**

<b>Activity</b>	<b>Generate ECU Extract</b>		
<b>Package</b>	AUTOSAR Root::M2::Methodology::Methodology Use Cases::System::Generate Ecu Extract		
<b>Brief Description</b>	Generate the ECU Extract out of the System Description in order to be delivered for integration for further development on ECU level.		
<b>Description</b>	<p>Generate the ECU extract which is a basis for setting up the ECU configuration and further development on ECU level.</p> <p>It can be generated either from a full system (System Configuration Description), a System Extract or a ECU System Description.</p>		
<b>Relation Type</b>	<b>Related Element</b>	<b>Mul.</b>	<b>Note</b>

<i>Relation Type</i>	<i>Related Element</i>	<i>Mul.</i>	<i>Note</i>
Consumes	<a href="#">ECU System Description</a>	0..1	
Consumes	<a href="#">System Configuration Description</a>	0..1	
Consumes	<a href="#">System Extract</a>	0..1	
Produces	<a href="#">ECU Extract</a>	1	
Aggregates	<a href="#">Extract ECU Topology</a>	1	
Aggregates	<a href="#">Extract the ECU Communication</a>	1	
Aggregates	<a href="#">Flatten Software Composition</a>	1	
Aggregates	<a href="#">Generate or Adjust ECU Flat Map</a>	1	

**Table 2.20: Generate ECU Extract**

## 2.6 Develop Basic Software

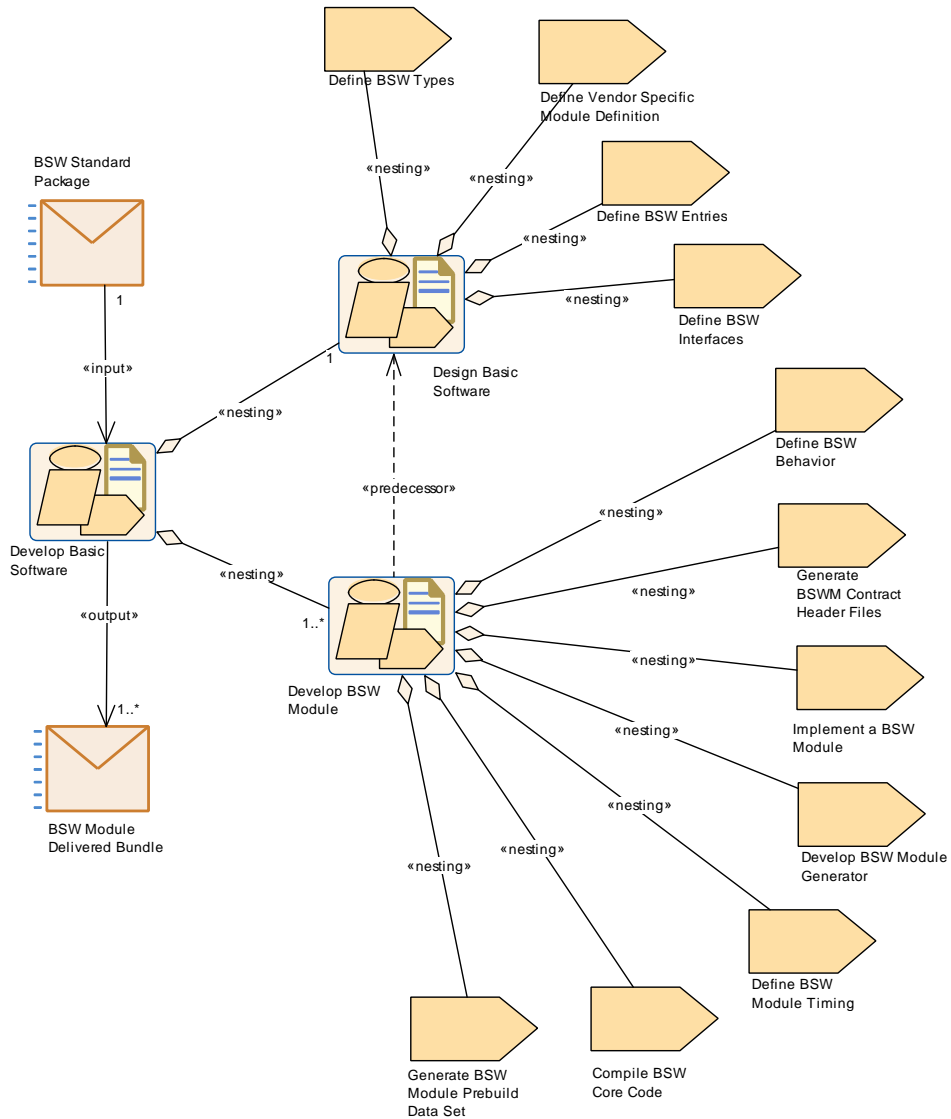
### 2.6.1 Overview

#### 2.6.1.1 Purpose

This *Activity* provides an overall use case how to the develop AUTOSAR Basic Software.

**2.6.1.2 Description**

**2.6.1.3 Workflow**



**Figure 2.23: Nesting relationship: Develop Basic Software**

<b>Activity</b>	<b>Develop Basic Software</b>		
<b>Package</b>	AUTOSAR Root::M2::Methodology::Methodology Use Cases::BSW::develop_bsw		
<b>Brief Description</b>			
<b>Description</b>	Describes the overall activities to develop Basic Software, starting from the design down to delivery of modules.		
<b>Relation Type</b>	<b>Related Element</b>	<b>Mul.</b>	<b>Note</b>
Consumes	BSW Standard Package	1	
Produces	BSW Module Delivered Bundle	1..*	

<i>Relation Type</i>	<i>Related Element</i>	<i>Mul.</i>	<i>Note</i>
Aggregates	<a href="#">Design Basic Software</a>	1	
Aggregates	<a href="#">Develop BSW Module</a>	1..*	

**Table 2.21: Develop Basic Software**

It consists of two parts:

- [Design Basic Software](#)
- [Develop BSW Module](#)

## 2.6.2 Design BSW

### 2.6.2.1 Purpose

This *Activity* provides a rough outline for the Basic Software design for an ECU or a set of ECUs.

### 2.6.2.2 Description

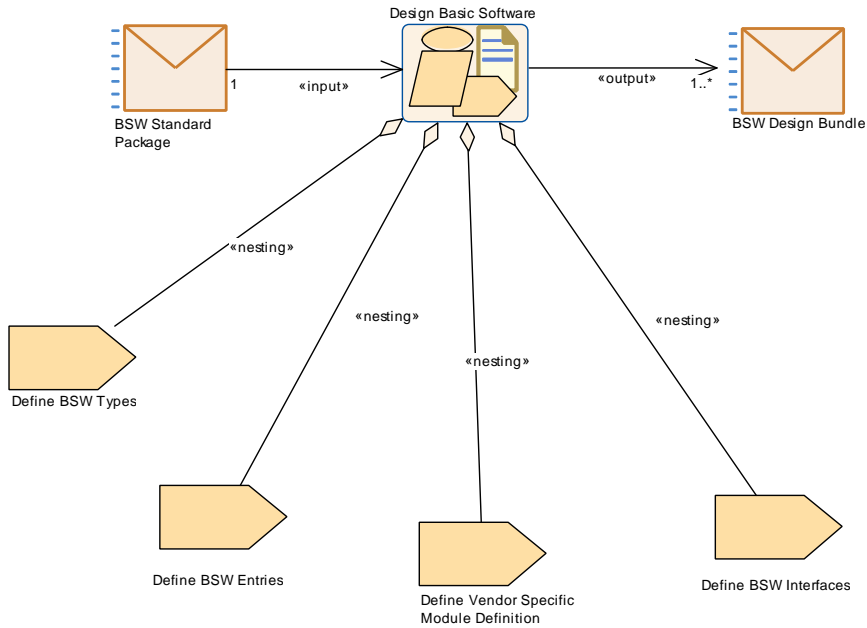
**[TR\_METH\_01083] Design Basic Software activity** [ Design the Basic Software for an ECU or a set of ECUs. This shall result in a set of complete and unambiguous [Basic Software Module Descriptions](#). ]([RS\\_METH\\_00003](#), [RS\\_METH\\_00004](#))

Note that existing descriptions, especially standardized ones, can be reused, eventually setting only optional elements or user specific extension.

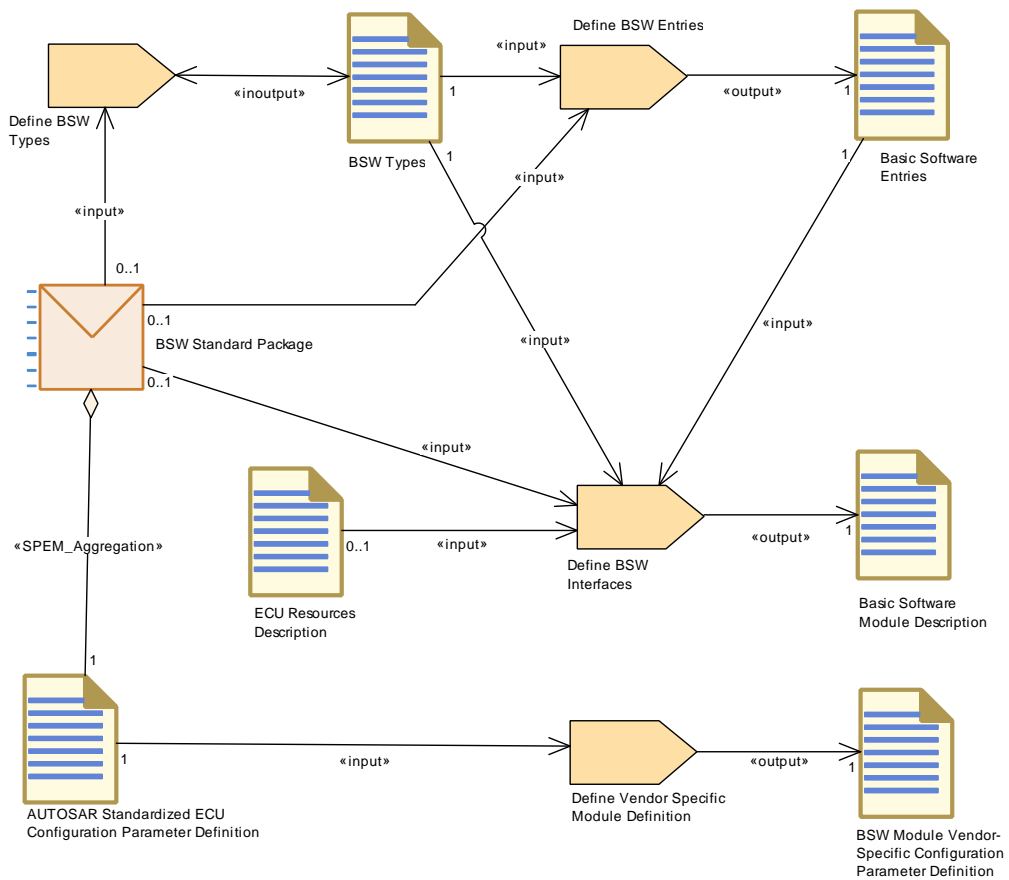
**[TR\_METH\_01084] Separation of design and development of basic software** [ This *Activity* is conceptually separated from [Develop BSW Module](#), because it might be performed by a [Basic Software Designer](#) responsible for the complete Basic Software Design on a given ECU, which may be different in general from the Basic Software Module Developer who develops or delivers the single modules. ]([RS\\_METH\\_00003](#), [RS\\_METH\\_00018](#))



**2.6.2.3 Workflow**



**Figure 2.24: Nesting Relationship : Design Basic Software**



**Figure 2.25: Design Basic Software**

<b>Activity</b>	<b>Design Basic Software</b>		
<b>Package</b>	AUTOSAR Root::M2::Methodology::Methodology Use Cases::BSW::develop_bsw		
<b>Brief Description</b>	Design the Basic Software for an ECU or a set of ECUs.		
<b>Description</b>	<p>Design the Basic Software for an ECU or a set of ECUs. This shall result in a set of complete and unambiguous Basic Software Module Description. Note that existing descriptions, especially standardized ones, can be reused, eventually setting only optional elements or user specific extension.</p> <p>This activity is conceptually separated from the activity Develop Basic Software Module, because it might be performed by a Basic Software Designer responsible for the complete Basic Software Design on a given ECU, which may be different (in general) from the Basic Software Module Developer who develops and/or delivers the single modules.</p>		
<b>Relation Type</b>	<b>Related Element</b>	<b>Mul.</b>	<b>Note</b>
Consumes	<a href="#">BSW Standard Package</a>	1	
Produces	<a href="#">BSW Design Bundle</a>	1..*	
Aggregates	<a href="#">Define BSW Entries</a>	1	
Aggregates	<a href="#">Define BSW Interfaces</a>	1	
Aggregates	<a href="#">Define BSW Types</a>	1	
Aggregates	<a href="#">Define Vendor Specific Module Definition</a>	1	

**Table 2.22: Design Basic Software**

## 2.6.3 Develop BSW Module

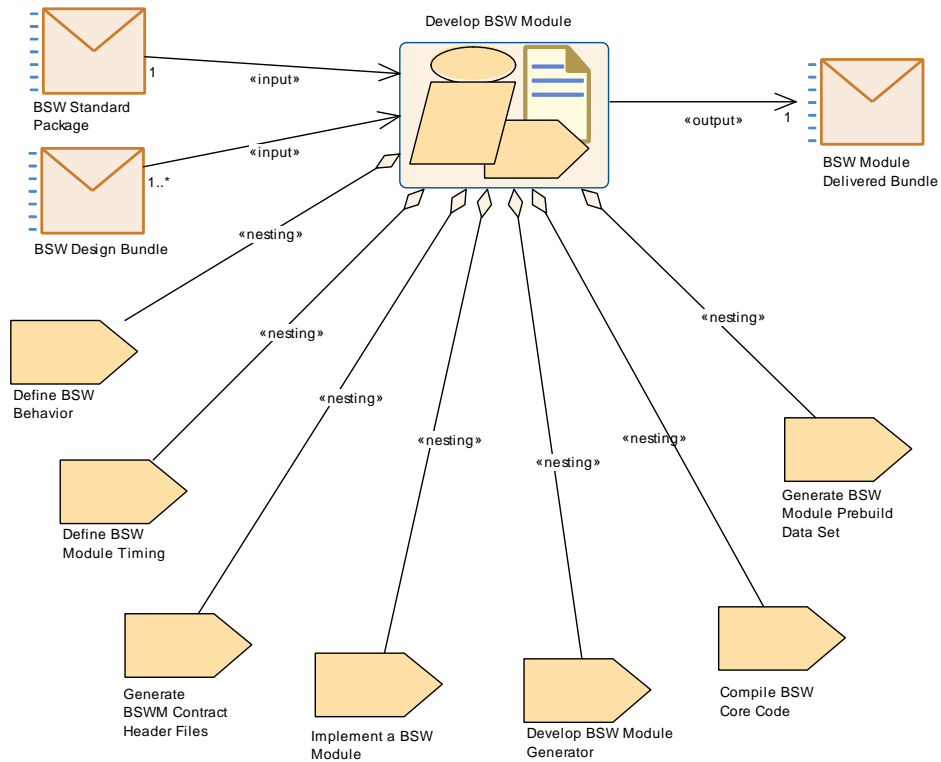
### 2.6.3.1 Purpose

This *Activity* provides a rough outline for a single Basic Software module or cluster development prior to an ECU integration.

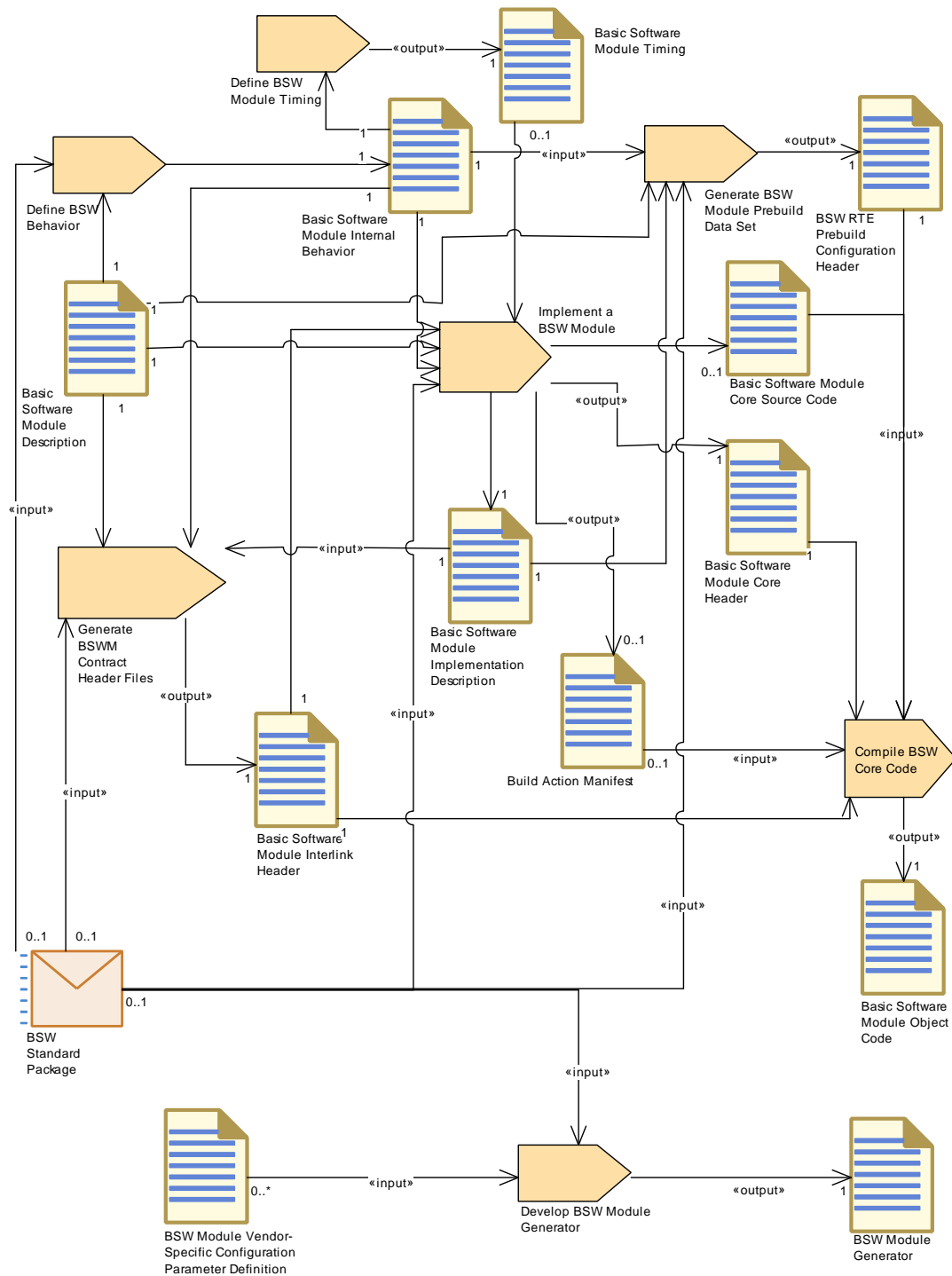
### 2.6.3.2 Description

**[TR\_METH\_01085] Develop BSW Module activity** [ To develop the core code (i.e. the code not generated during integration) of a single BSW module or cluster prior to ECU integration. This *Activity* focuses on the tasks which are common for most BSW modules. It is not valid for those modules (RTE, BSW Scheduler) which are completely generated at integration time. ] ([RS\\_METH\\_00003](#), [RS\\_METH\\_00006](#), [RS\\_METH\\_00038](#))

**2.6.3.3 Workflow**



**Figure 2.26: Nesting relationship : Develop Basic Software Module**



**Figure 2.27: Develop Basic Software Module**

<b>Activity</b>	<b>Develop BSW Module</b>		
<b>Package</b>	AUTOSAR Root::M2::Methodology::Methodology Use Cases::BSW::develop_bsw		
<b>Brief Description</b>	Develop a single BSW module or cluster prior to ECU integration.		
<b>Description</b>	<p>Develop a single BSW module or cluster prior to ECU integration.</p> <p>To develop the core code (i.e. the code not generated during integration) of a single BSW module or cluster prior to ECU integration including vendor specific configuration parameters and module generators. This activity focuses on the tasks which are common for most BSW modules. It is not valid for those modules (RTE, BSW Scheduler) which are completely generated at integration time.</p>		
<b>Relation Type</b>	<b>Related Element</b>	<b>Mul.</b>	<b>Note</b>
Consumes	BSW Design Bundle	1..*	
Consumes	BSW Standard Package	1	
Produces	BSW Module Delivered Bundle	1	
Aggregates	Compile BSW Core Code	1	
Aggregates	Define BSW Behavior	1	
Aggregates	Define BSW Module Timing	1	
Aggregates	Develop BSW Module Generator	1	
Aggregates	Generate BSW Module Prebuild Data Set	1	
Aggregates	Generate BSWM Contract Header Files	1	
Aggregates	Implement a BSW Module	1	
Predecessor	Design Basic Software	1	
Predecessor	Design Basic Software	1	

**Table 2.23: Develop BSW Module**

## 2.7 Integrate Software for ECU

### 2.7.1 Description

In this chapter, the integration for an AUTOSAR ECU is described. In the AUTOSAR sense an ECU means a microcontroller plus peripherals and the according software/-configuration. Therefore, each microcontroller requires its own ECU Configuration.

**[TR\_METH\_01086] Integrate Software for ECU activity** [ The main activities include configuring and/or generating the BSW modules (including the RTE) and building the executable. The BSW configuration can be done during different steps of development. The detailed use cases for these different ways of configuration are introduced later in the chapter, thanks to the `Configuration Classes` definition :

- Pre-compile time
- Link time
- Post-build time

]([RS\\_METH\\_00004](#), [RS\\_METH\\_00062](#))

## 2.7.2 Overview

### 2.7.2.1 Purpose

This `Activity` is showing the high level view how to integrate AUTOSAR Software for an ECU.

### 2.7.2.2 Description

**[TR\_METH\_01087] Scope of Integrate Software for ECU activity** [ The development of an AUTOSAR ECU consists of four main activities:

- `Prepare ECU Configuration`
- `Configure BSW and RTE`
- `Generate BSW and RTE`
- `Build Executable`

In addition, the optional activity `Model ECU Timing` is shown. The ECU timing model depends on ECU configuration details (BSW and RTE), but the results shall help to optimize the configuration in an iterative approach. ]([RS\\_METH\\_00005](#), [RS\\_METH\\_00003](#), [RS\\_METH\\_00004](#), [RS\\_METH\\_00002](#), [RS\\_METH\\_00006](#))

The ECU configuration plays a significant role during the integration of the software for an ECU. The relevant workflow is depicted in figure 2.29<sup>1</sup>. All three activities (`Prepare ECU Configuration`, `Configure BSW and RTE`, `Generate BSW and RTE`) use the work product `ECU Configuration Values` which contains (i.e. references) all the configuration information for all BSW modules on the ECU. In order to better understand the three different activities an introduction to configuration classes is given in chapter 2.7.8.

---

<sup>1</sup>In order to be more comprehensible, this figure hides some outputs of the activity `Generate BSW and RTE`. For more details see the outputs of all aggregated tasks.

One can measure resources used by the various BSW modules and applications and save that information within the [Basic Software Module Implementation Description](#) or [Atomic Software Component Implementation](#).

One can also generate an [A2L File](#) processing the [Generate A2L](#) task at this point.

### 2.7.2.2.1 Inputs to ECU Configuration

**[TR\_METH\_01114] Input sources for ECU Configuration** [ ECU Configuration has two input sources (see figure 2.29). First of all, all configuration that must be agreed across ECUs is defined in the System Configuration, which results in a [System Configuration Description](#) (and the resulting [ECU Extract](#) for the individual ECUs).

Secondly, the ECU BSW is built using BSW modules. The specifics of these module implementation are defined in the BSW Module descriptions covered by the [BSW Module Delivered Bundle](#). ]([RS\\_METH\\_00003](#), [RS\\_METH\\_00004](#), [RS\\_METH\\_00005](#), [RS\\_METH\\_00006](#))

The latter is described in [5] in more detail. The concept of the [ECU Extract](#) is depicted below:

#### ECU Extract

ECU Configuration can only be started once a plausible [System Configuration Description](#) and the corresponding [ECU Extract](#) has been generated (see figure 2.29). Details on the [System Configuration Description](#) can be found in [6].

The [System Configuration Description](#) contains all relevant system-wide configuration, such as

- ECUs present in the system
- Communication systems interconnecting those ECUs and their configuration
- Communication matrices (frames sent and received) for those communication systems
- Definition of Software Components with their ports and interfaces and connections (defined in the SWC Description and referenced in the [System Configuration Description](#)).
- Mapping of SWCs to ECUs

The [ECU Extract](#) is a description in the same format as the [System Configuration Description](#), but with only those elements included that are relevant for the configuration of one specific ECU.

### 2.7.2.2.2 ECU Configuration Value description

The [ECU Extract](#) only defines the configuration elements that must be agreed between ECUs. In order to generate a working executable that runs on the ECU, much more configuration information must be provided.

The remaining part of the configuration is about configuring all BSW modules within the ECU. Typical BSW modules within an ECU can be: RTE, Com, Can, OS, NVRAM etc. There are also dependencies between BSW modules to consider when configuring the ECU.

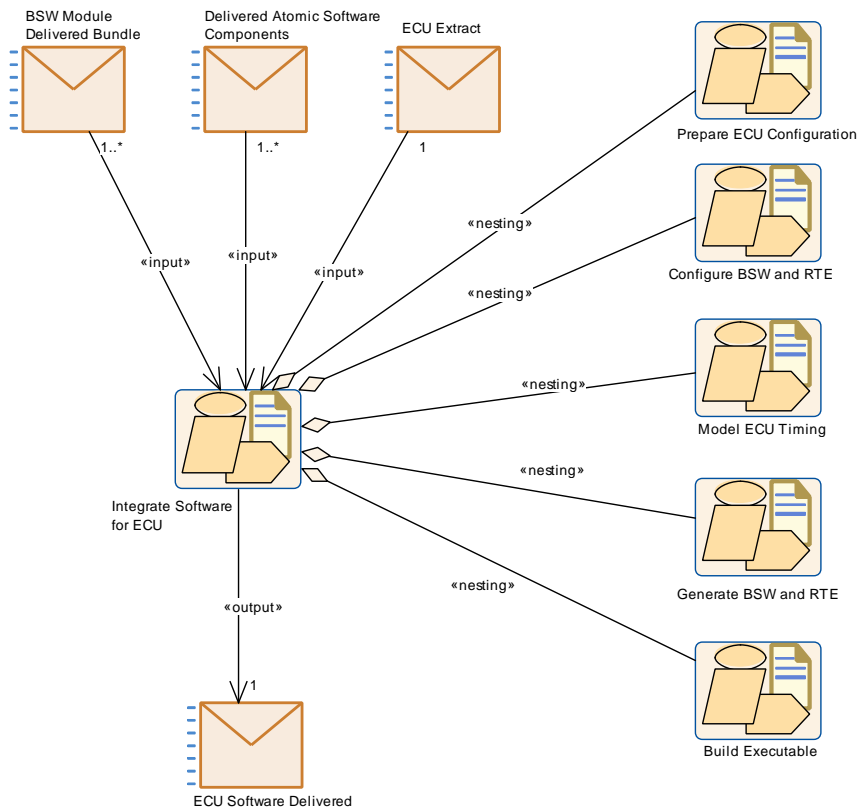
When the configuration is done, the generation of configuration data takes place. I.e. there are both configuration editors and configuration generators involved in the process.

In order to obtain consistency within the overall configuration of the ECU, AUTOSAR has defined a single format, the ECU Configuration Value description to be used for all BSW modules within an ECU. Both configuration editors and configuration generators are working toward ECU Configuration Value descriptions. In the AUTOSAR Methodology the ECU Configuration Value descriptions is represented by the artifact [ECU Configuration Values](#).

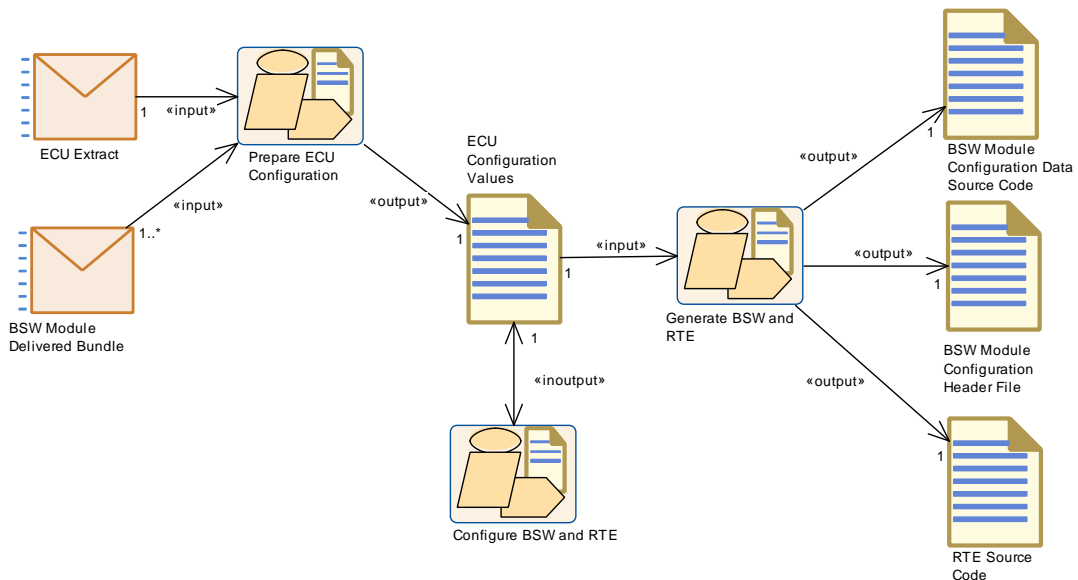
**[TR\_METH\_01116] ECU Configuration Value description contains the configuration of all BSW modules in a single ECU** [ This one description ([ECU Configuration Values](#)) collects the complete configuration of BSW modules in a single ECU. Each module generator may then extract the subset of configuration data it needs from that single format. ]([RS\\_METH\\_00004](#))



**2.7.2.3 Workflow**



**Figure 2.28: Integrate Software for ECU Overview**



**Figure 2.29: ECU Configuration Overview**

<b>Activity</b>	<b>Integrate Software for ECU</b>		
<b>Package</b>	AUTOSAR Root::M2::Methodology::Methodology Use Cases::ECU:: Integrate Software for ECU		
<b>Brief Description</b>			
<b>Description</b>	<p>This activity contains all typical sub-activities required to integrate the software components and modules on an AUTOSAR ECU.</p> <p>ECU in this context means processor, so if an electronic control unit consists of several processors, one "ECU Delivered" will be needed for each processor.</p>		
<b>Relation Type</b>	<b>Related Element</b>	<b>Mul.</b>	<b>Note</b>
Consumes	<a href="#">BSW Module Delivered Bundle</a>	1..*	
Consumes	<a href="#">Delivered Atomic Software Components</a>	1..*	
Consumes	<a href="#">ECU Extract</a>	1	
Produces	<a href="#">ECU Software Delivered</a>	1	
Aggregates	<a href="#">Build Executable</a>	1	
Aggregates	<a href="#">Configure BSW and RTE</a>	1	
Aggregates	<a href="#">Generate BSW and RTE</a>	1	
Aggregates	<a href="#">Model ECU Timing</a>	1	
Aggregates	<a href="#">Prepare ECU Configuration</a>	1	

**Table 2.24: Integrate Software for ECU**

## 2.7.3 Prepare ECU Configuration

### 2.7.3.1 Description

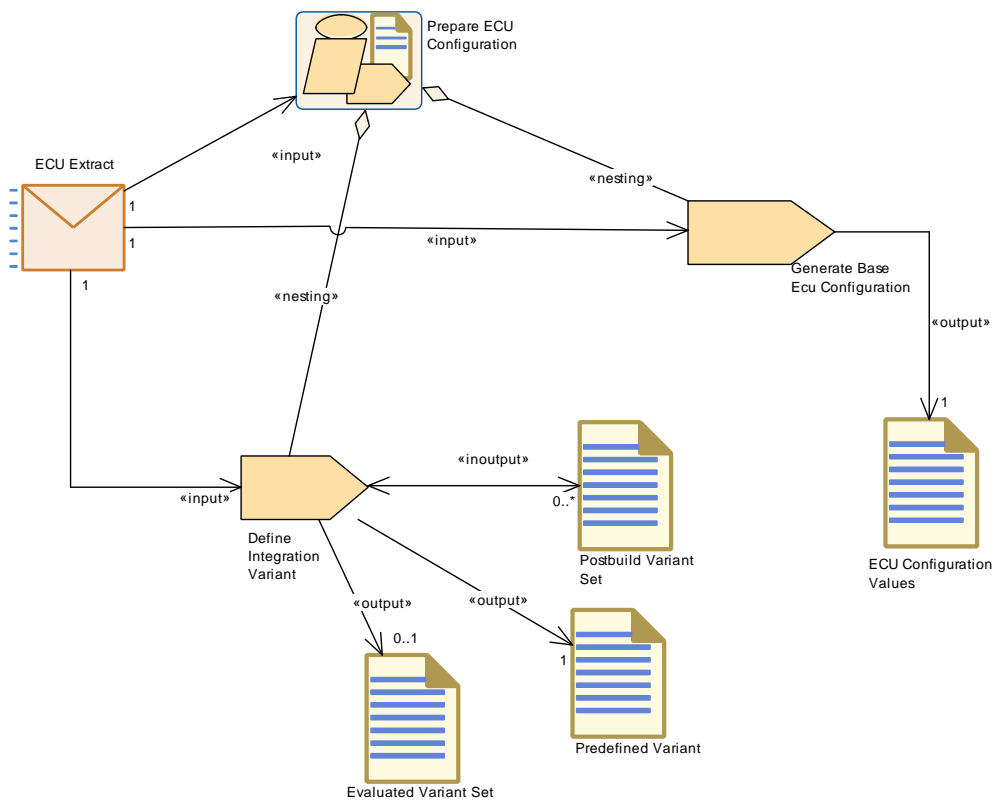
**[TR\_METH\_01088] Prepare ECU Configuration activity** [ During the [Prepare ECU Configuration](#) activity, the information available in [ECU Extract](#) for the specific ECU is extended by implementing the [Service Needs](#) required by the [Software Components](#) and [BSW Modules](#) and by including their initial configurations as provided in the [BSW Module Preconfigured Configuration](#) or [BSW Module Recommended Configuration](#). The result of this activity is the base [ECU Configuration](#).

In addition, the [BSW Module Vendor-Specific Configuration Parameter Definition](#), which defines all possible configuration parameters and their structure, is incorporated into the [ECU Configuration](#). This is necessary because the output [ECU Configuration](#) has a flexible structure which does not define a fixed number of configuration parameters a priori. ]([RS\\_METH\\_00005](#), [RS\\_METH\\_00003](#), [RS\\_METH\\_00004](#), [RS\\_METH\\_00002](#))

[TR\_METH\_01117] BSW implementation shall be chosen for each BSW module that is present in the ECU [ For each BSW module that shall be present in the ECU, the implementation must be chosen. This is done by referencing the BSW Module description delivered with the BSW module (BSW Module Delivered Bundle). ](RS\_METH\_00003, RS\_METH\_00004)

The rules that must be followed when building the base ECU Configuration Value description are available in [7] chapter 4.2.

### 2.7.3.2 Workflow



**Figure 2.30: Prepare ECU Configuration**

<b>Activity</b>	<b>Prepare ECU Configuration</b>		
<b>Package</b>	AUTOSAR Root::M2::Methodology::Methodology Use Cases::ECU::Integrate Software for ECU		
<b>Brief Description</b>			
<b>Description</b>	Initial actions required to create the initial ECU Configuration.		
<b>Relation Type</b>	<b>Related Element</b>	<b>Mul.</b>	<b>Note</b>
Consumes	BSW Module Delivered Bundle	1..*	
Consumes	ECU Extract	1	
Produces	ECU Configuration Values	1	

<i>Relation Type</i>	<i>Related Element</i>	<i>Mul.</i>	<i>Note</i>
Aggregates	<a href="#">Define Integration Variant</a>	1	
Aggregates	<a href="#">Generate Base Ecu Configuration</a>	1	

**Table 2.25: Prepare ECU Configuration**

## 2.7.4 Configure BSW and RTE

### 2.7.4.1 Description

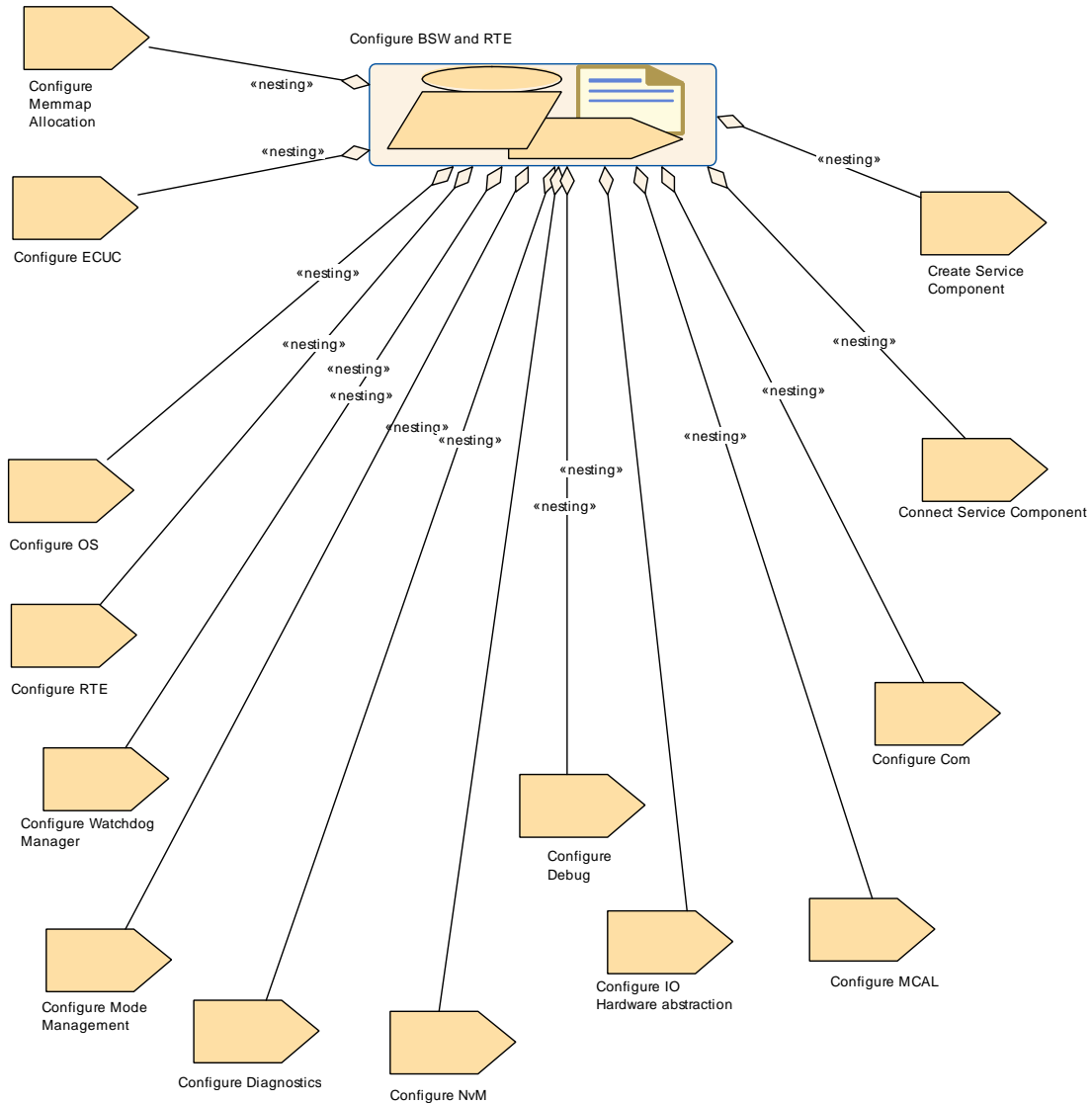
**[TR\_METH\_01089] Configure BSW and RTE activity** [ Once there is a base ECU Configuration, the complete configuration can be performed. This is mainly editing work on the ECU Configuration which is typically supported by an editing tool. In practice this will require iterations and/or parallel work to configure the RTE and all participating BSW modules. ]([RS\\_METH\\_00003](#), [RS\\_METH\\_00004](#), [RS\\_METH\\_00020](#))

The methodology does not prescribe a certain order of these configuration steps. The ECU Configuration description (e.g. [ECU Configuration Values](#)) which was produced by one activity can be read by another activity (e.g. [Configure RTE](#) generates a description and [Configure Com](#) reads this). Usually the configuration activities for the BSW modules (e.g. COM and OS) read and write the ECU Configuration.

**[TR\_METH\_01090] Configure RTE task** [ The [Configure RTE](#) task is more complex as this additionally needs all the [Atomic Software Component Implementations](#) required for that ECU. Whenever these change, e.g. because software components have been moved to or from other ECUs, or simply another implementation of a software component has been selected, the [Configure RTE](#) task must be repeated as well. ]([RS\\_METH\\_00005](#), [RS\\_METH\\_00003](#), [RS\\_METH\\_00004](#), [RS\\_METH\\_00002](#))

**[TR\_METH\_01091] Configure Debug task** [ Finally the [Configure Debug](#) task can be completed. Since this configuration depends on previous configuration results, it should be completed last. ]([RS\\_METH\\_00005](#), [RS\\_METH\\_00003](#), [RS\\_METH\\_00004](#), [RS\\_METH\\_00002](#))

**2.7.4.2 Workflow**



**Figure 2.31: Configure BSW and RTE**

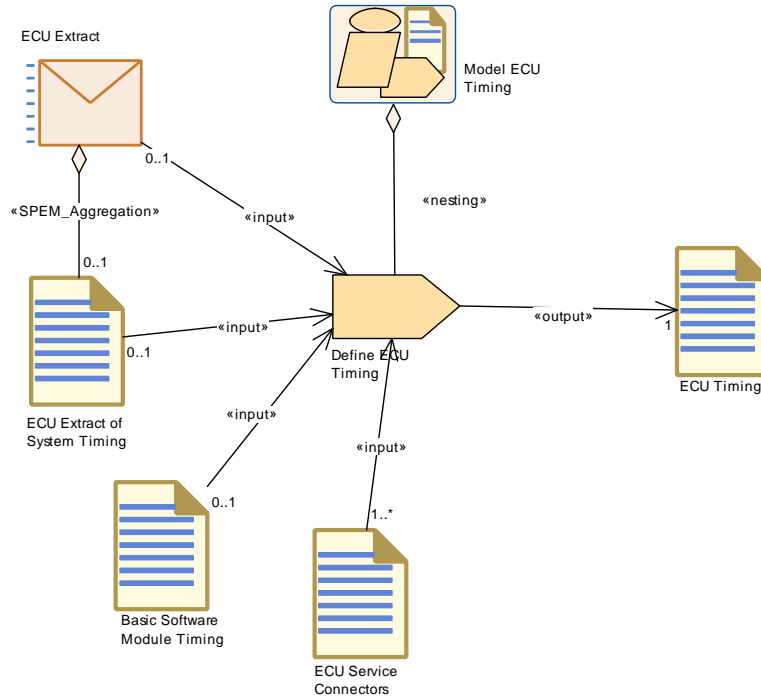
<b>Activity</b>	<b>Configure BSW and RTE</b>		
<b>Package</b>	AUTOSAR Root::M2::Methodology::Methodology Use Cases::ECU:: Integrate Software for ECU		
<b>Brief Description</b>			
<b>Description</b>	All the tasks used to configure the Basic Software Modules on an ECU.		
<b>Relation Type</b>	<b>Related Element</b>	<b>Mul.</b>	<b>Note</b>
Aggregates	<a href="#">Configure Com</a>	1	
Aggregates	<a href="#">Configure Debug</a>	1	
Aggregates	<a href="#">Configure Diagnostics</a>	1	
Aggregates	<a href="#">Configure ECUC</a>	1	
Aggregates	<a href="#">Configure IO Hardware abstraction</a>	1	

<i>Relation Type</i>	<i>Related Element</i>	<i>Mul.</i>	<i>Note</i>
Aggregates	Configure MCAL	1	
Aggregates	Configure Memmap Allocation	1	
Aggregates	Configure Mode Management	1	
Aggregates	Configure NvM	1	Since the configuration of the DEM usually has impact on the data to be stored in NvM, the task Configure Diagnostics is assumed to precede the task Configure NvM.
Aggregates	Configure OS	1	
Aggregates	Configure RTE	1	
Aggregates	Configure Watchdog Manager	1	
Aggregates	Connect Service Component	1	
Aggregates	Create Service Component	1	
Predecessor	Prepare ECU Configuration	1	
In/out	ECU Configuration Values	1	

**Table 2.26: Configure BSW and RTE**

## 2.7.5 Model ECU Timing

### 2.7.5.1 Workflow



**Figure 2.32: Model ECU Timing**

<b>Activity</b>	<b>Model ECU Timing</b>		
<b>Package</b>	AUTOSAR Root::M2::Methodology::Methodology Use Cases::ECU:: Integrate Software for ECU		
<b>Brief Description</b>			
<b>Description</b>	ECU timing model depends on ECU configuration data (BSW and RTE) but the result of the ECU timing model shall help to optimize ECU configuration. The relation between "Configure BSW and RTE" and "Model ECU Timing" must be seen as an iterative work.		
<b>Relation Type</b>	<b>Related Element</b>	<b>Mul.</b>	<b>Note</b>
Aggregates	Define ECU Timing	1	
Predecessor	Configure BSW and RTE	1	

**Table 2.27: Model ECU Timing**

## 2.7.6 Generate BSW and RTE

### 2.7.6.1 Description

**[TR METH 01092] Generating BSW modules, RTE, and OS source files** [ After the ECU Configuration is completed, the BSW modules, RTE, and OS source

files are generated. `|(RS_METH_00005, RS_METH_00003, RS_METH_00004, RS_METH_00006)`

Generation is the process of applying the tailored ECU Configuration Value description to the software modules. This can be performed in different ways, and is dependent on the configuration classes chosen for the different modules (see 2.7.8), and on implementers choices.

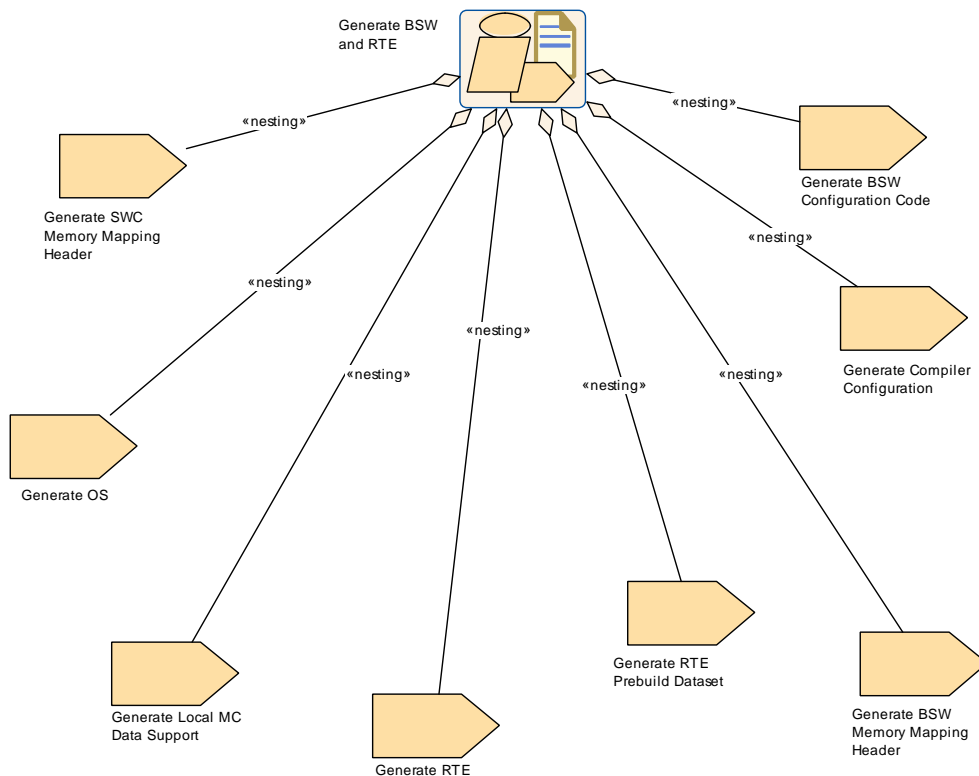
For each BSW module, a generator reads the relevant parameters from the ECU Configuration Value description and creates code that implements the specified configuration.

In this generation step, the abstract parameters of the ECU Configuration Value description are translated to hardware and implementation-specific data structures that fit to the implementation of the corresponding software module. The AUTOSAR Methodology specification does not specify the generator tools in detail.

It is assumed however that generators perform error, consistency and completeness checks on the part of the configuration they require for generation.

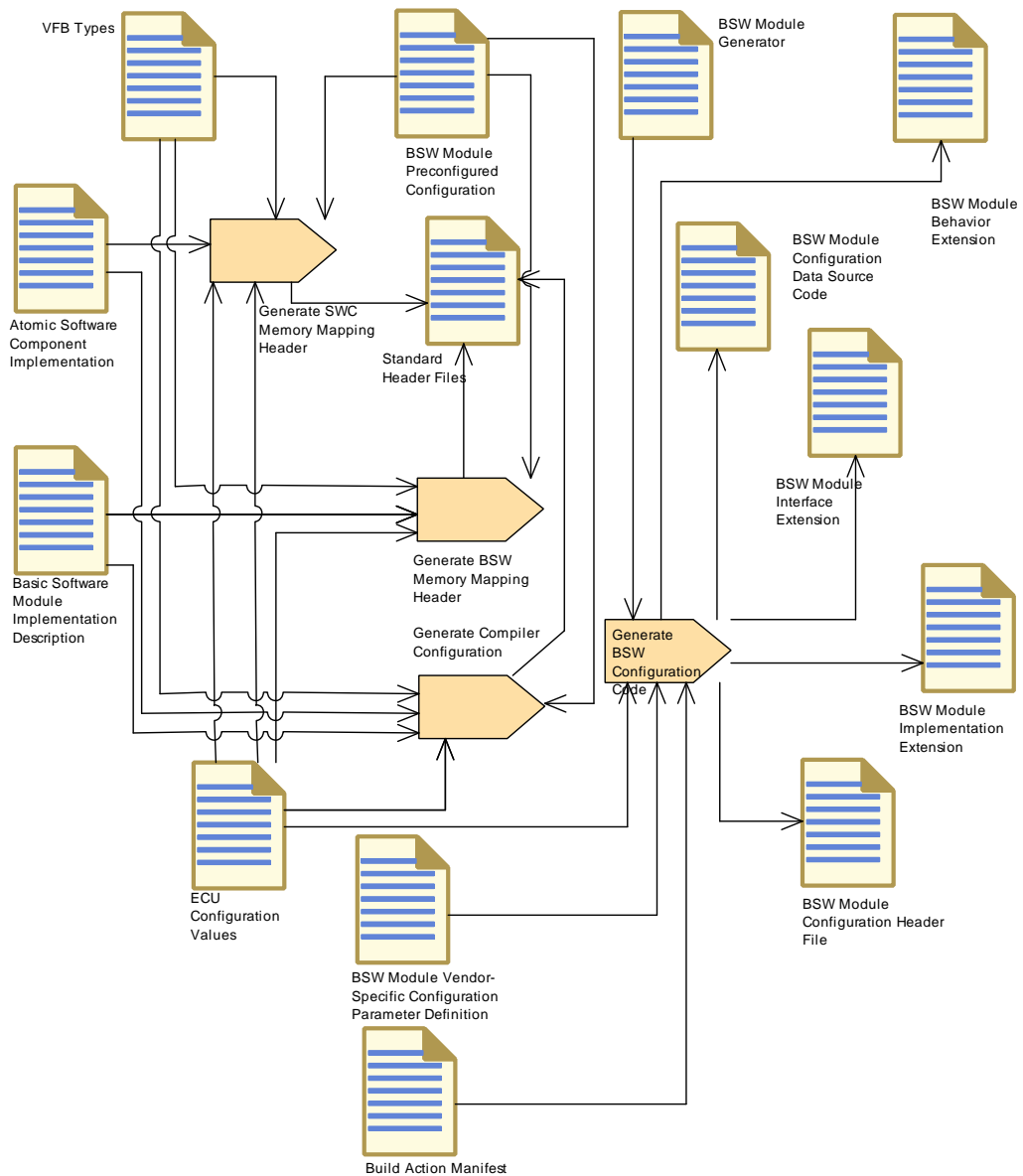
There are some alternative approaches when it comes to generation of configuration data. See chapter A.1.2 in [7] for more details.

### 2.7.6.2 Workflow

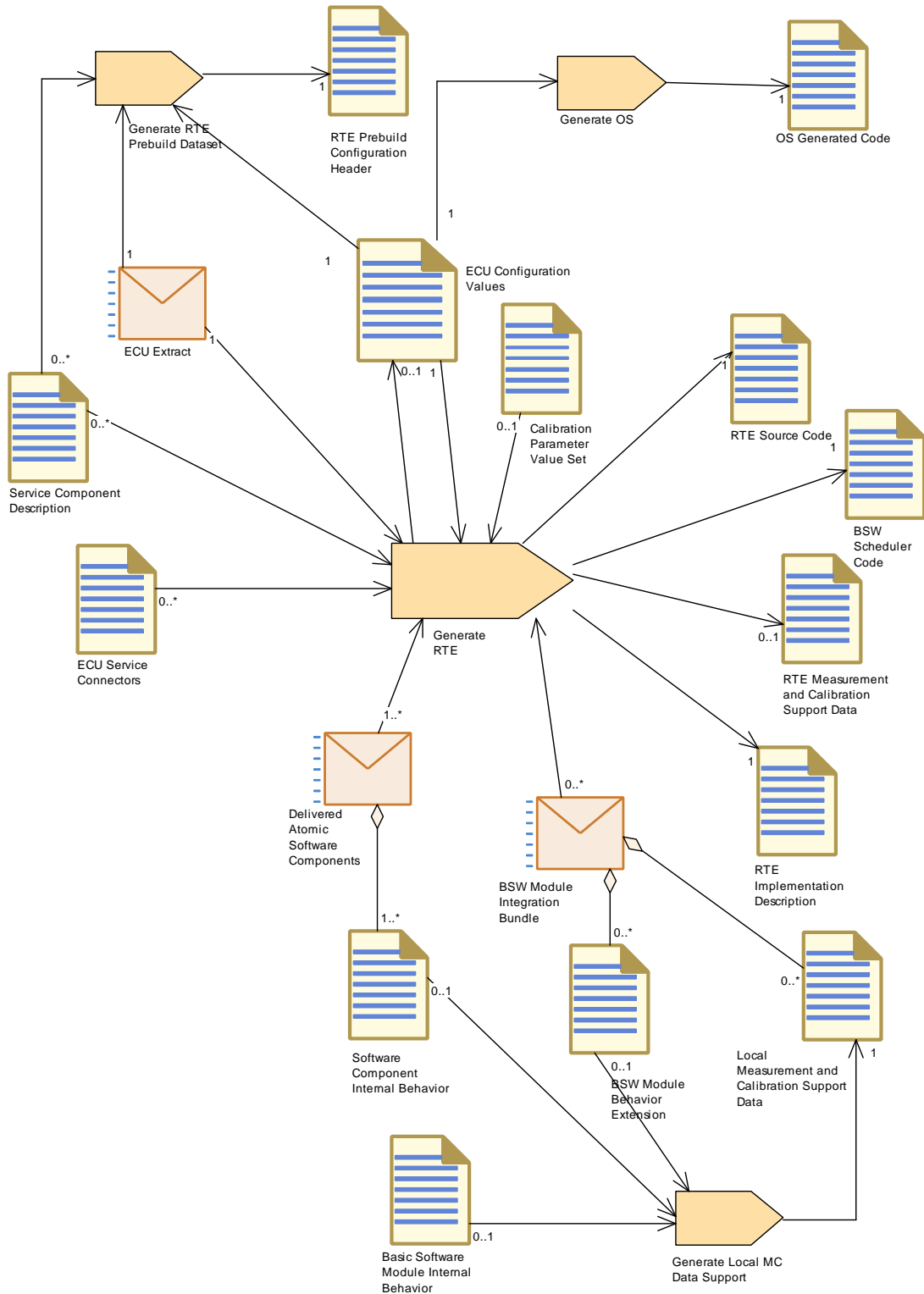


**Figure 2.33: Generate BSW and RTE**





**Figure 2.34: Generate BSW and RTE (Part 1)**



**Figure 2.35: Generate BSW and RTE(Part 2)**

<b>Activity</b>	<b>Generate BSW and RTE</b>		
<b>Package</b>	AUTOSAR Root::M2::Methodology::Methodology Use Cases::ECU::Integrate Software for ECU		
<b>Brief Description</b>	High Level view showing how to build an AUTOSAR ECU software.		
<b>Description</b>	<p>There are many possibilities how to run the configuration of the different modules in detail (see the detailed use cases for the configuration classes).</p> <p>This overall use case shows the generation of RTE, OS and Memory Mapping explicitly, for the other modules it shows as an example the generic task required for link time configuration of the modules plus the generic task to generate local calibration support data.</p>		
<b>Relation Type</b>	<b>Related Element</b>	<b>Mul.</b>	<b>Note</b>
Consumes	ECU Configuration Values	1	
Produces	BSW Module Configuration Data Source Code	1	
Produces	BSW Module Configuration Header File	1	
Produces	RTE Source Code	1	
Aggregates	Generate BSW Configuration Code	1	
Aggregates	Generate BSW Memory Mapping Header	1	
Aggregates	Generate Compiler Configuration	1	
Aggregates	Generate Local M C Data Support	1	
Aggregates	Generate OS	1	
Aggregates	Generate RTE	1	
Aggregates	Generate RTE Prebuild Dataset	1	
Aggregates	Generate SWC Memory Mapping Header	1	
Predecessor	Configure BSW and RTE	1	

**Table 2.28: Generate BSW and RTE**

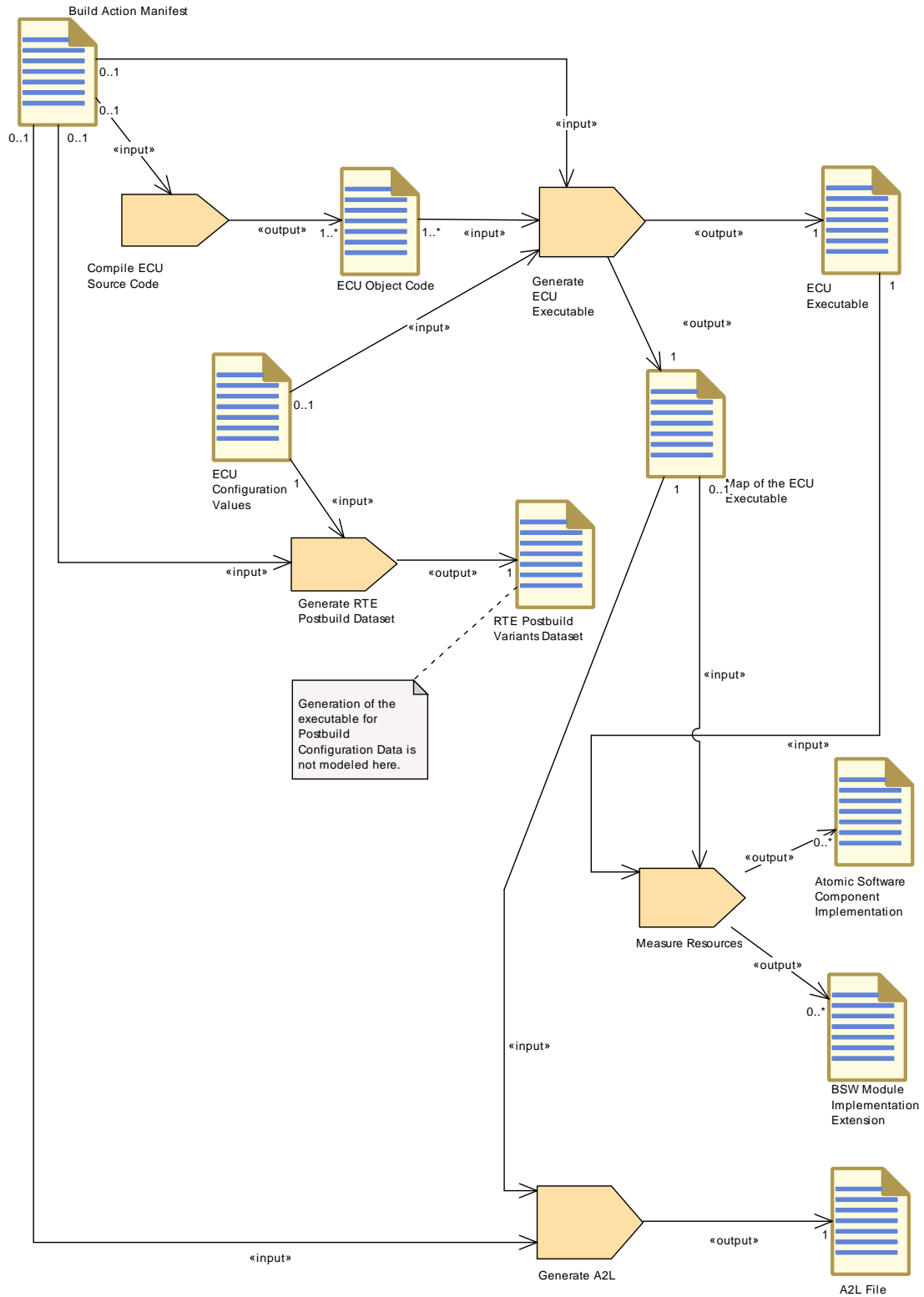
## 2.7.7 Build Executable

### 2.7.7.1 Description

[TR\_METH\_01093] **Building ECU Executable** [ These are compiled and linked along with all the applications, libraries, etc. to build the **ECU Executable**. The

details of the various compiling and linking options are explained in the chapters [2.7.8.1](#), [2.7.8.2](#), [2.7.8.3](#) and [2.7.8.4](#). [|\(RS\\_METH\\_00006, RS\\_METH\\_00042, RS\\_METH\\_00038\)](#)

**2.7.7.2 Workflow**



**Figure 2.36: Build Executable**

<b>Activity</b>	<b>Build Executable</b>		
<b>Package</b>	AUTOSAR Root::M2::Methodology::Methodology Use Cases::ECU:: Integrate Software for ECU		
<b>Brief Description</b>			
<b>Description</b>	Describes how to build one executable and related artifacts (A2L file) starting from the source code (and delivered object code).		
<b>Relation Type</b>	<b>Related Element</b>	<b>Mul.</b>	<b>Note</b>
Aggregates	Compile ECU Source Code	1	
Aggregates	Generate A2L	1	
Aggregates	Generate ECU Executable	1	
Aggregates	Generate RTE Postbuild Dataset	1	
Aggregates	Measure Resources	1	
Predecessor	Generate BSW and RTE	1	

**Table 2.29: Build Executable**

## 2.7.8 Configuration Classes

The development of BSW modules involve the following development cycles: compiling, linking and downloading of the executable to ECU memory. Configuration of parameters can be done in any of these process-steps: pre-compile time, link time or even post-build time.

According to the process-step that does the configuration of parameters, the configuration classes are categorized as below

- pre-compile time
- link time
- post-build time

The configuration in different process-steps has some consequences for the handling of ECU configuration parameters. If a configuration parameter is defined as pre-compile time, after compilation this configuration parameter can not be changed any more.

Or if a configuration parameter is defined at post-build time the configuration parameter has to be stored at a known memory location. Also, the format in which the BSW module is delivered determines in what way parameters are changeable. A source code delivery or an object code delivery of a BSW module has different degrees of freedom regarding the configuration.

The configuration class of a parameter depends on the chosen implementation variants of the BSW module it belongs to. However once the module is implemented, the

configuration class for each of the parameters is fixed. Choosing the right implementation variant for a module depends on the type of application and the design decisions taken by the module implementer.

Different configuration classes can be combined within one module. For example, for post-build time configurable BSW implementations only a subset of the parameters might be configurable post-build time. Some parameters might be configured as pre-compile time or link time.

File formats used for describing the configuration classes:

- `.arxml` (An xml file standardized by AUTOSAR.)
- `.exe` (An executable that can be downloaded to an ECU.)
- `.hex` (A binary file that can be downloaded to an ECU , but it can not execute by its own.)
- `.c` (A C-source file containing either source code or configuration data.)
- `.h` (A header file for either source code or configuration data.)
- `.obj` (A object file for either source code or configuration data.)

**[TR\_METH\_01115] A mix of parameters with different configuration classes within a BSW module is allowed** [ In a real implementation of a BSW module all configuration parameters are most likely not in the same configuration class. I.e it will be a mix of parameters with different configuration classes within a BSW module. ]([RS\\_METH\\_00003](#), [RS\\_METH\\_00004](#))

### 2.7.8.1 Configuration Class: Pre-compile Time

**[TR\_METH\_01095] Configuration Class: Pre-compile Time** [ ([TPS\_ECUC\_01031], see [7]) This type of configuration is a standalone configuration done before compiling the source code. That means parameter values for those configurable elements are selected before compiling and will be effective after compilation time. The value of the configurable parameter is decided in earlier stage of software development process and any changes in the parameter value calls for a re-compilation. The contents of pre-compile time parameters can not be changed at the subsequent development steps like link time or post-build time. ]([RS\\_METH\\_00004](#), [RS\\_METH\\_00062](#))

#### 2.7.8.1.1 Description

The work breakdown structure shows two approaches:

**[TR\_METH\_01096] Generating header files only** [ The first approach is to generate a [BSW Module Configuration Header File](#), then compile the module core code

using this header file. In this case the module core code is not touched by the BSW Configuration Generator. ]

**[TR\_METH\_01097] Generating header and source files** [ An alternative approach, in which the BSW Configuration Generator generates the complete, configuration-specific [BSW Module Configuration Header Files](#) plus [BSW Module Completely Generated Source Code](#). In this case, no core code exist. ]

Both approaches are equally valid.

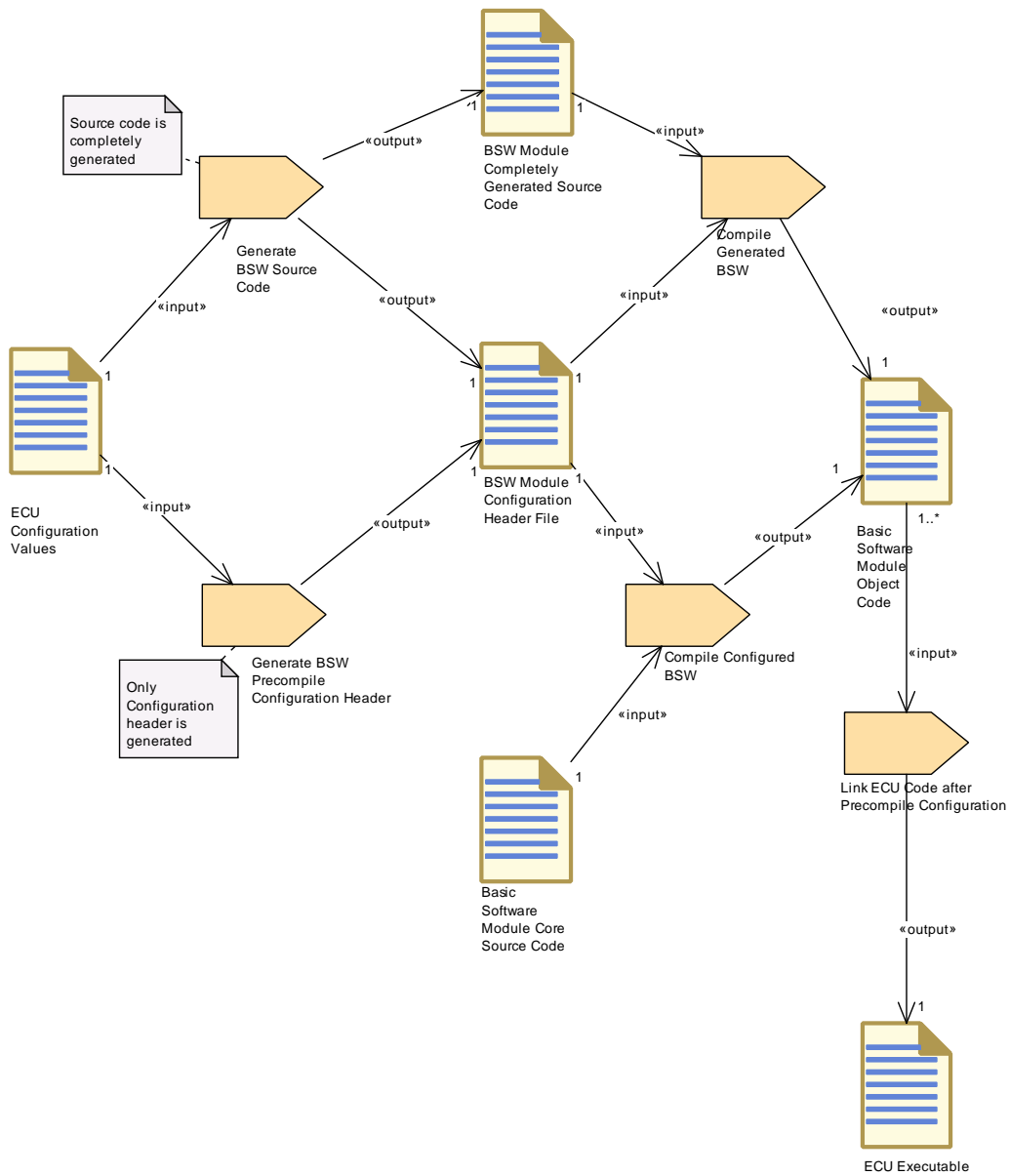
Whenever the decision of parameter value must be taken before the selection of other dependable parameters, pre-compile time configuration is the right choice. For example, the algorithm choice for CRC initial checksum parameter is based on the selection of CRC type (CRC16 or CRC32). When CRC16 is selected, there will be increase in processing time but reduction in memory usage. Whereas when CRC32 is selected, there will be decrease in processing time but increase in memory usage. The correct choice should be made by the implementer before compilation of source code based on the requirement and resource availability.

Sample cases where pre-compile time configuration can be adopted are:

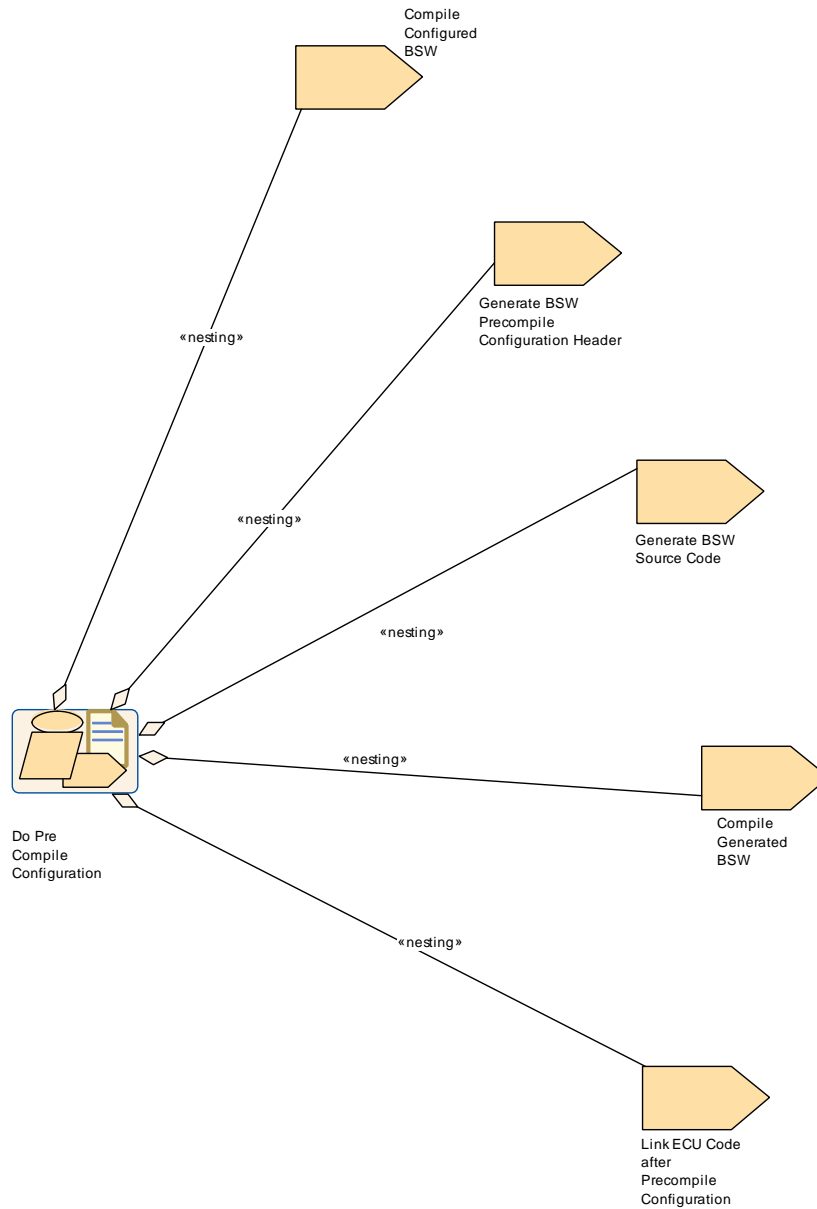
- Configure the number of memory tables and block descriptor table of NVRAM manager.
- Enable the macro for the development error tracing of the software modules.



**2.7.8.1.2 Workflow**



**Figure 2.37: Pre-compile time configuration overview**



**Figure 2.38: Pre compile time configuration activities**

<b>Activity</b>	<b>Do Pre Compile Configuration</b>		
<b>Package</b>	AUTOSAR Root::M2::Methodology::Methodology Use Cases::ECU::Pre Compile Conf		
<b>Brief Description</b>			
<b>Description</b>	[from ecuc sws 1031] This type of configuration is a standalone configuration done before compiling the source code. That means parameter values for those configurable elements are defined before compiling and will be effective after compilation time. The value of the configurable parameter is decided in an earlier stage of software development process and any changes in the parameter value calls for a re-compilation. The contents of pre-compile time parameters cannot be changed at the subsequent development steps like link time or post-build time.		
<b>Relation Type</b>	<b>Related Element</b>	<b>Mul.</b>	<b>Note</b>
Aggregates	<a href="#">Compile Configured BSW</a>	1	
Aggregates	<a href="#">Compile Generated BSW</a>	1	
Aggregates	<a href="#">Generate BSW Precompile Configuration Header</a>	1	
Aggregates	<a href="#">Generate BSW Source Code</a>	1	
Aggregates	<a href="#">Link ECU Code after Precompile Configuration</a>	1	

**Table 2.30: Do Pre Compile Configuration**

### 2.7.8.2 Configuration Class: Link Time

**[TR\_METH\_01098] Configuration Class: Link Time** [ ([TPS\_ECUC\_01032], see [7]) This type of configuration is done for the BSW module during link time. That means the object code of the BSW module receives parts of its configuration from another object code file or it is defined by linker options. Link time parameters are typically used when delivering object code to the integrator. ] ([RS\\_METH\\_00004](#), [RS\\_METH\\_00062](#))

#### 2.7.8.2.1 Description

This configuration class provides a modular approach to the configuration process. A separate module will handle the configuration details and those parameter values will be made available to the other modules during the linking process.

**[TR\_METH\_01099] Generation and compilation of BSW Configuration Code** [ The first step is to [Generate BSW Configuration Code](#), which produces the [BSW Module Configuration Data Source Code](#) and the [BSW Module Configuration Header File](#). These are compiled along with the [Basic Software Mod-](#)

ule Core Header into the BSW Module Configuration Data Object Code.  
]

**[TR\_METH\_01100] Definition of configuration data** [ The configuration parameter data is defined in a common header file [Basic Software Module Core Header](#) and included by both [Basic Software Module Core Source Code](#) and [BSW Module Configuration Data Source Code](#). The module source file needs this header file to resolve the references and module configuration source file will need it in order to cross check the declaration of data type against the definition. ]

**[TR\_METH\_01101] Separate compilation of module source and configuration file** [ Both module source file and module configuration source file are compiled separately to generate [Basic Software Module Object Code](#) and [BSW Module Configuration Data Object Code](#) respectively. ]

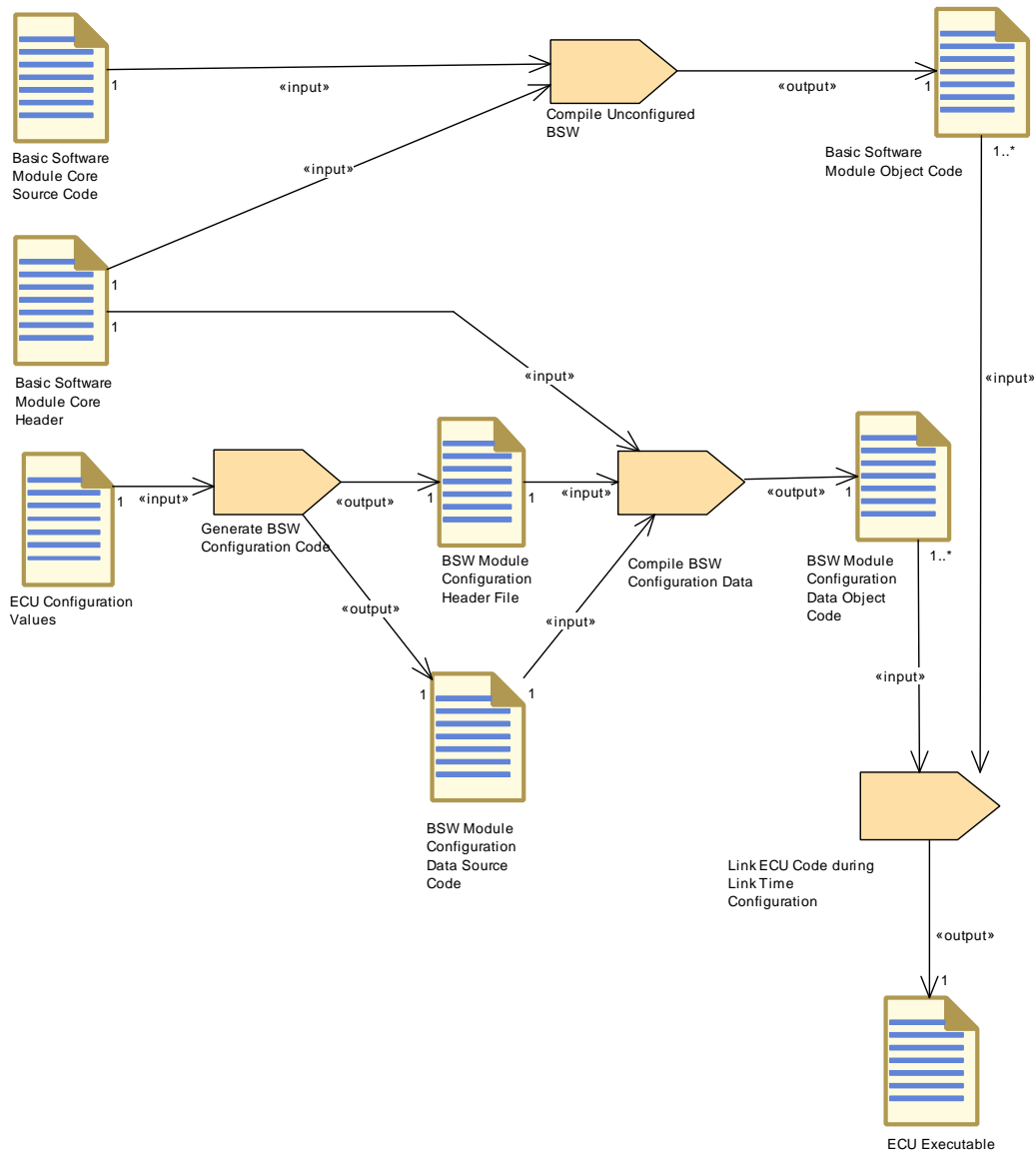
**[TR\_METH\_01102] Linking process** [ During the linking process, the configuration data will be available to [Basic Software Module Object Code](#) by resolving the external references. ]

**[TR\_METH\_01103] Re-generation in case of configuration value changes** [ When the values of configuration parameters change the [Basic Software Module Object Code](#) needs to be re-generated. ] ([RS\\_METH\\_00004](#))

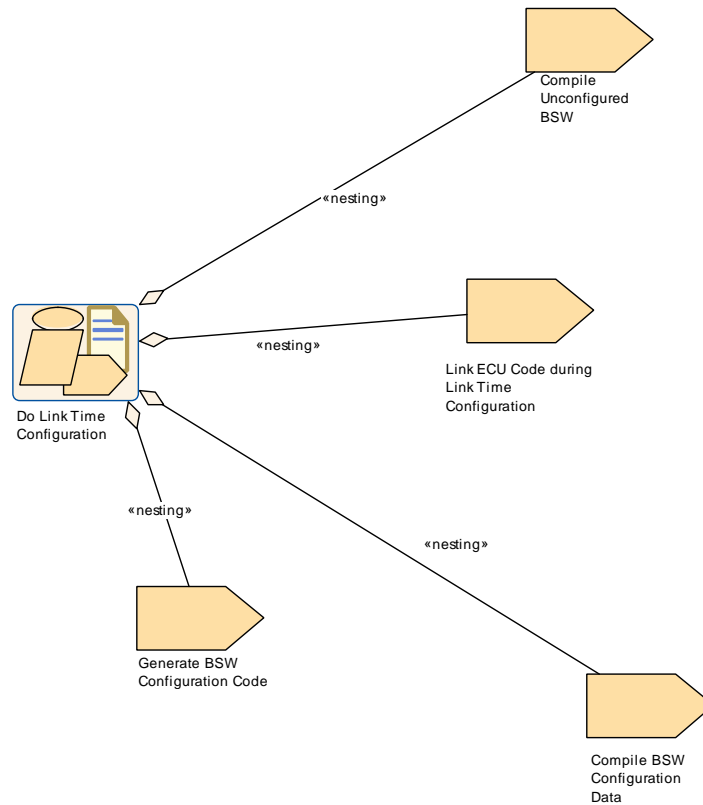
Sample cases where Link time configuration can be adopted are:

- Initial value and invalid value of signal
- Unique channel identifier configured for the respective instance of the Network Management.
- Logical handle of CAN network.
- Identifier and type of Hardware Reception Handle and Hardware Transmission
- Handle for CAN interface.
- Definition of ComFilterAlgorithm.
- COM callback function to indicate RTE about the reception of an invalidated signal.

**2.7.8.2.2 Workflow**



**Figure 2.39: Overview Link Time Configuration**



**Figure 2.40: Link time configuration**

<b>Activity</b>	<b>Do Link Time Configuration</b>		
<b>Package</b>	AUTOSAR Root::M2::Methodology::Methodology Use Cases::ECU::Link Time Conf		
<b>Brief Description</b>			
<b>Description</b>	[from ecuc sws 1032] This type of configuration is done for the BSW module during link time. That means the object code of the BSW module receives parts of its configuration from another object code file or it is defined by linker options. Link time parameters are typically used when delivering object code to the integrator.		
<b>Relation Type</b>	<b>Related Element</b>	<b>Mul.</b>	<b>Note</b>
Aggregates	Compile BSW Configuration Data	1	
Aggregates	Compile Unconfigured BSW	1	
Aggregates	Generate BSW Configuration Code	1	
Aggregates	Link ECU Code during Link Time Configuration	1	

**Table 2.31: Do Link Time Configuration**

### 2.7.8.3 Configuration Class: Post-build Time Loadable

**[TR\_METH\_01104] Configuration Class: Post-build Time Loadable** [ (TPS\_ECUC\_04006), see [7]) This type of configuration is possible after building the BSW module or the ECU software. The BSW module gets the parameters of its configuration by downloading a separate file to the ECU memory, avoiding a re-compilation and re-build of the BSW module. ] ([RS\\_METH\\_00004](#), [RS\\_METH\\_00062](#))

#### 2.7.8.3.1 Description

There are two different approaches:

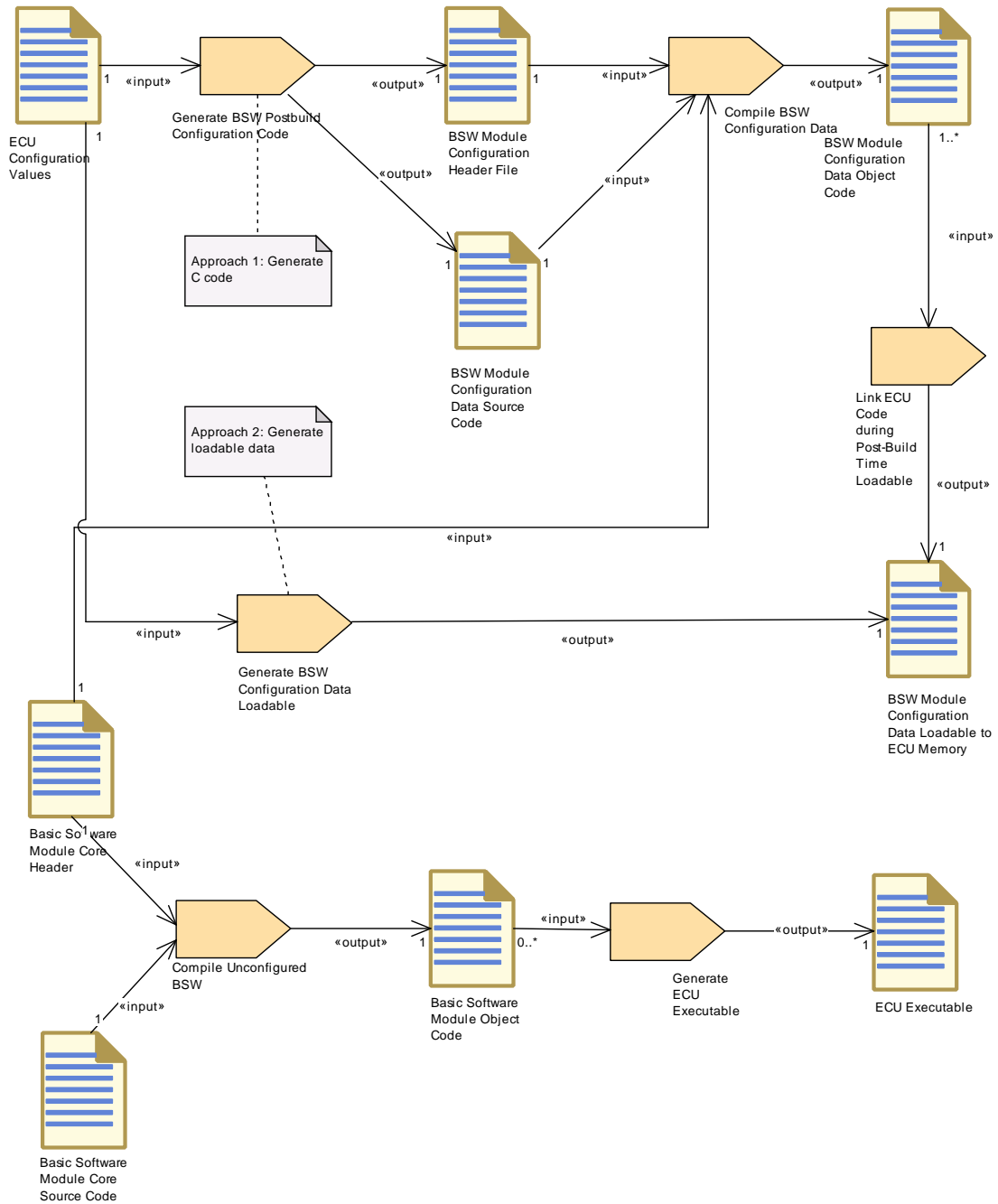
**[TR\_METH\_01105] Generate BSW Postbuild Configuration Code** [ In order to make the post-build time loadable re-configuration possible, the re-configurable parameters shall be stored at a known memory location of the ECU memory. In this approach the [Basic Software Module Core Source Code](#) is compiled and linked independently of its configuration data. The BSW Configuration Generator generates the configuration data as [BSW Module Configuration Data Source Code](#) that is compiled and linked independently of the core source code. ]

**[TR\_METH\_01106] Generate BSW Configuration Data Loadable** [ In the second approach, the [BSW Module Configuration Data Loadable to ECU Memory](#) is stored at a known memory location and it is possible to exchange the configuration data without replacing the [ECU Executable](#). The difference compared to the first approach is that the BSW Configuration Generator does perform also the tasks performed by the compiler and linker in the prior approach. I.e the [BSW Module Configuration Data Loadable to ECU Memory](#) is generated directly by this generator. The configuration data and the executable is still independently exchangeable. ]

Sample cases where post-build time loadable configuration can be adopted are:

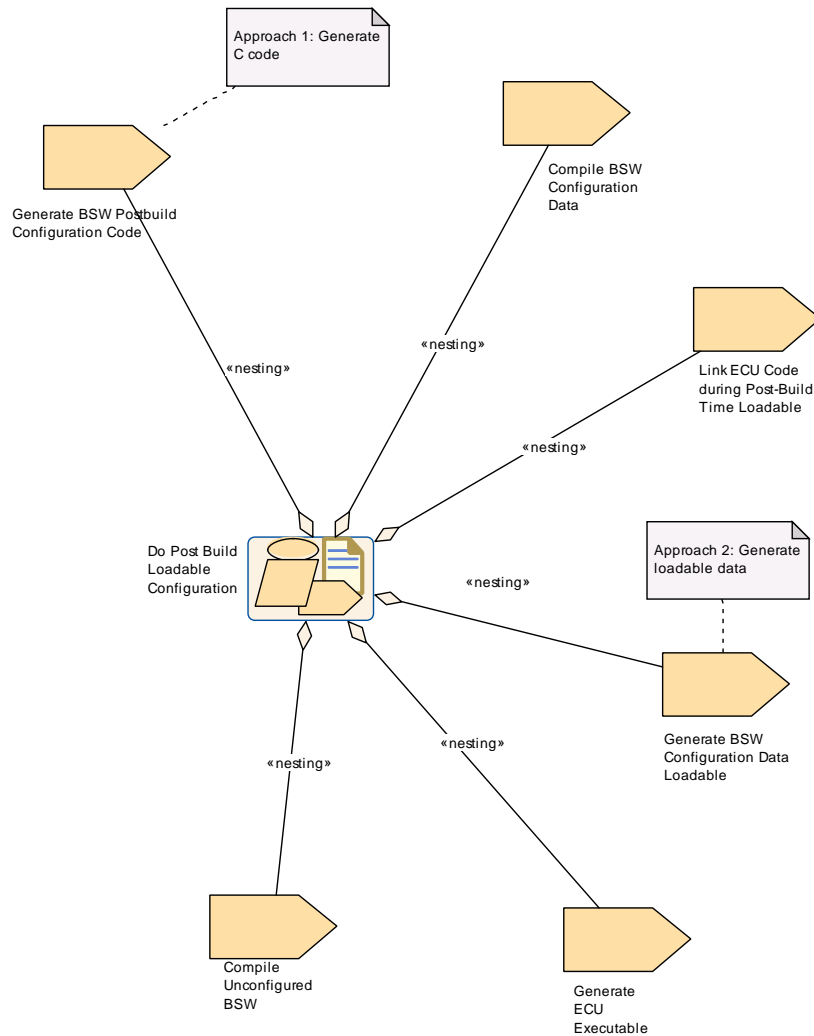
- Identifiers of the CAN frames
- CAN driver baudrate and propagation delay
- COM transmission mode, transmission mode time offset and time period
- Enabling/disabling signal transmission
- Frame packing
- Signal gateway
- LIN/FlexRay schedule

**2.7.8.3.2 Workflow**



**Figure 2.41: Overview of Post-Build loadable Configuration**





**Figure 2.42: Work Flow for Post-Build loadable Configuration**

<b>Activity</b>	<b>Do Post Build Loadable Configuration</b>		
<b>Package</b>	AUTOSAR Root::M2::Methodology::Methodology Use Cases::ECU::Post Build Loadable Conf		
<b>Brief Description</b>			
<b>Description</b>	[from ecuc sws 4006] This type of configuration is possible after building the BSW module or the ECU software. The BSW module gets the parameters of its configuration by downloading a separate file to the ECU memory, avoiding a re-compilation and re-build of the BSW module.		
<b>Relation Type</b>	<b>Related Element</b>	<b>Mul.</b>	<b>Note</b>
Aggregates	Compile BSW Configuration Data	1	
Aggregates	Compile Unconfigured BSW	1	
Aggregates	Generate BSW Configuration Data Loadable	1	

<i>Relation Type</i>	<i>Related Element</i>	<i>Mul.</i>	<i>Note</i>
Aggregates	Generate BSW Postbuild Configuration Code	1	
Aggregates	Generate ECU Executable	1	
Aggregates	Link ECU Code during Post-Build Time Loadable	1	

**Table 2.32: Do Post Build Loadable Configuration**

#### 2.7.8.4 Configuration Class: Post-build Time Selectable

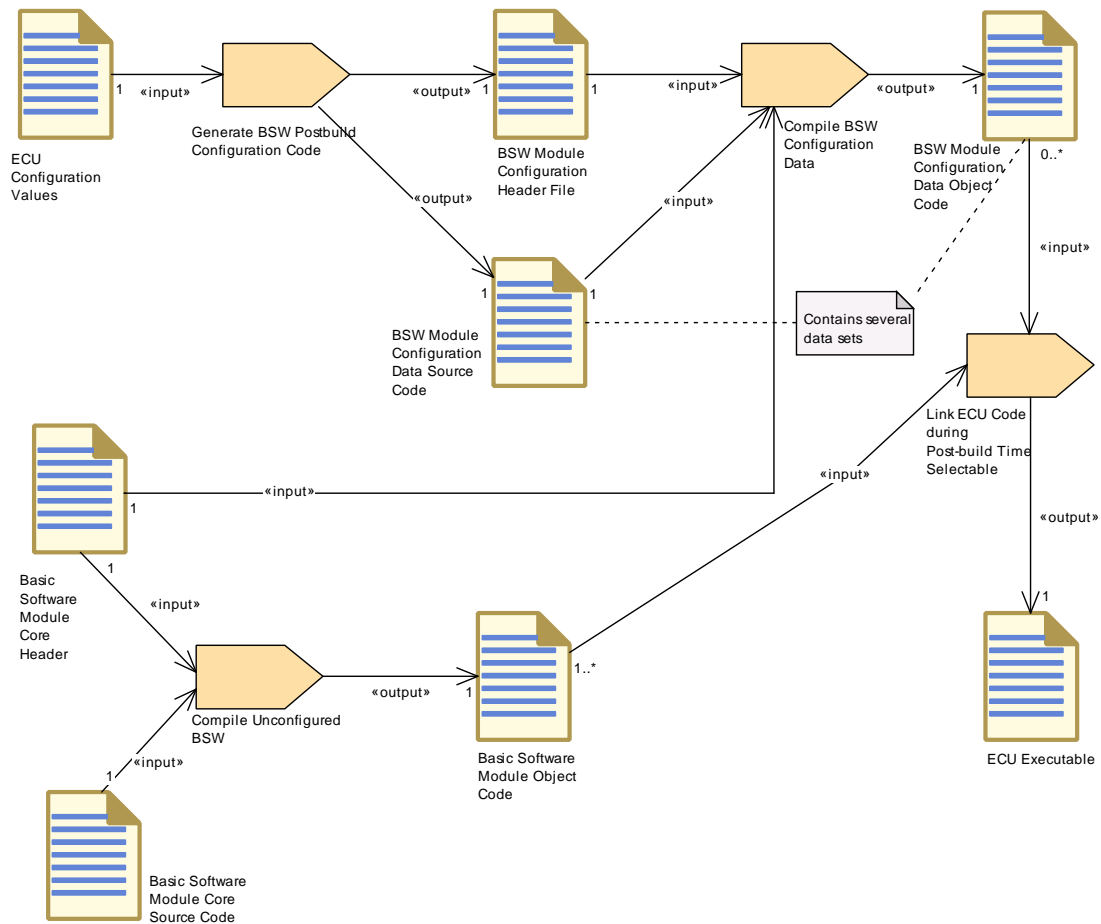
**[TR\_METH\_01107] Configuration Class: Post-build Time Selectable** [ ([TPS\_ECUC\_04007], see [7]) Post-build time selectable makes it possible to define multiple configuration sets. Which set will become active is chosen during boot-time. ] ([RS\\_METH\\_00004](#), [RS\\_METH\\_00062](#))

##### 2.7.8.4.1 Description

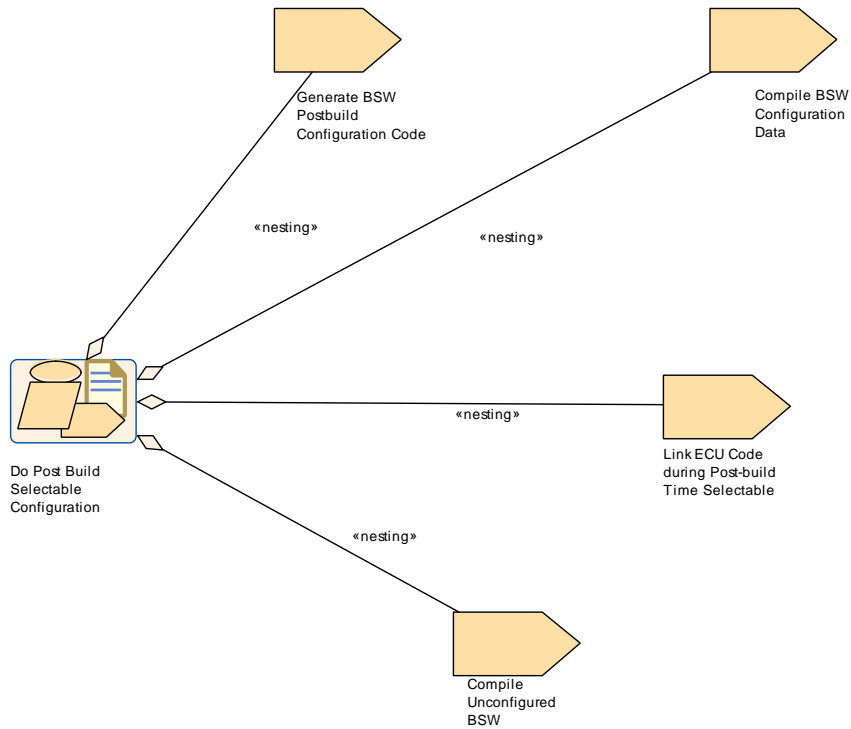
**[TR\_METH\_01108] Generating multiple configuration parameter sets** [ In this use case, the BSW Configuration Generator generates two or more sets of configuration parameters within [BSW Module Configuration Header Files](#) and [BSW Module Configuration Data Source Code](#). The configuration data is compiled and linked together with the [Basic Software Module Core Source Code](#).

The resulting [ECU Executable](#) includes all configuration sets as well as the source code of the BSW module. I.e. it is not possible to exchange the configuration data without re-building the entire executable. ]

**2.7.8.4.2 Workflow**



**Figure 2.43: Overview of Post-Build Selectable Configuration**



**Figure 2.44: Post-Build Selectable Configuration**

<b>Activity</b>	<b>Do Post Build Selectable Configuration</b>		
<b>Package</b>	AUTOSAR Root::M2::Methodology::Methodology Use Cases::ECU:: Post Build Selectable Conf		
<b>Brief Description</b>			
<b>Description</b>	[from ecuc sws 4007]Post-build time selectable makes it possible to define multiple configuration sets. Which set will become active is chosen during boot-time.		
<b>Relation Type</b>	<b>Related Element</b>	<b>Mul.</b>	<b>Note</b>
Aggregates	Compile BSW Configuration Data	1	
Aggregates	Compile Unconfigured BSW	1	
Aggregates	Generate BSW Postbuild Configuration Code	1	
Aggregates	Link ECU Code during Post-build Time Selectable	1	

**Table 2.33: Do Post Build Selectable Configuration**

## 2.8 Components and Services

### 2.8.1 Purpose

This use case focuses on the activities required to use and configure AUTOSAR Services. It is therefore a subset of the overall use case (see 2.1).

### 2.8.2 Description

**[TR\_METH\_02000] Use of AUTOSAR Services** [Atomic Software Components can use AUTOSAR Services. In order to do so, two things have to be defined on the VFB and Software Component level:

- The ports which are to be connected to the Service during ECU integration (this is a sub-task of [Define VFB Application Software Component](#)). The port interfaces used for service ports should be standardized.
- The needs to configure the Service (for example NvM blocks or symbolic names for diagnostic events) from the perspective of the single Software Component (this is a sub-task of [Define Atomic Software Component Internal Behavior](#).)

]([RS\\_METH\\_00002](#), [RS\\_METH\\_00033](#))

The service ports have impact on the component API just like any other port, so there is no difference between service ports and "normal" ports with respect to API generation.

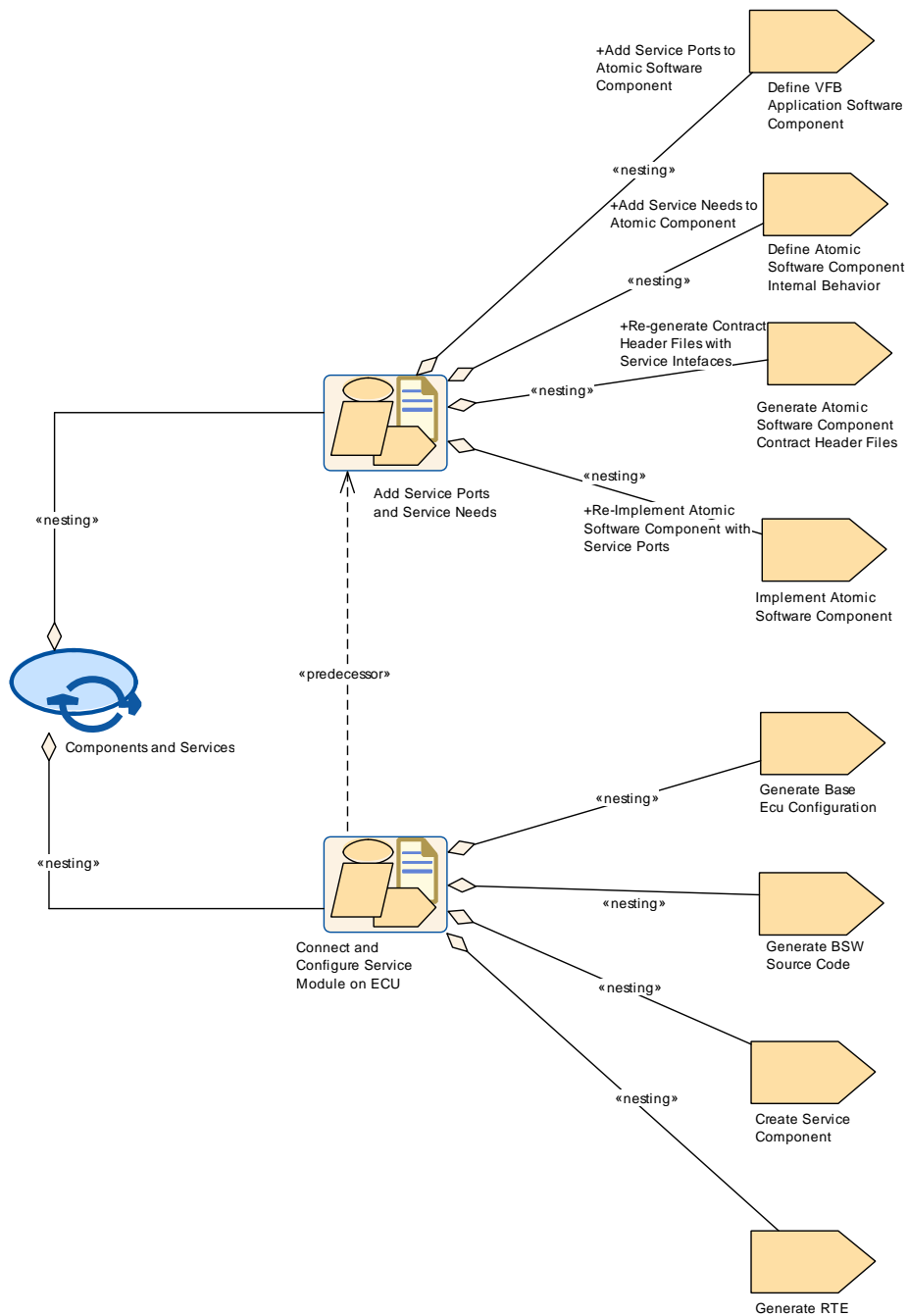
When the Application Software Components are mapped to an ECU their description is put into the corresponding [ECU Extract](#). These activities belong to the System domain (see 2.5.6) and are not explicitly shown in this use case.

As part of the ECU integration, additional artifacts are generated to connect the service ports over the RTE: [Service Component Descriptions](#), including their mapping to the Basic Software Modules, and the connectors between their ports and the service ports of the Application Software Components.

The use case shows also the creation of ECU configuration of the corresponding Basic Software Module (e.g. DEM, DCM, Watchdog Manager etc.). This must be done with respect to the service ports and the [Service Needs](#) of all Application Software Components connected to the corresponding Service Component (the diagram shows only the configuration activity of diagnostics as an example).

### 2.8.3 Workflow

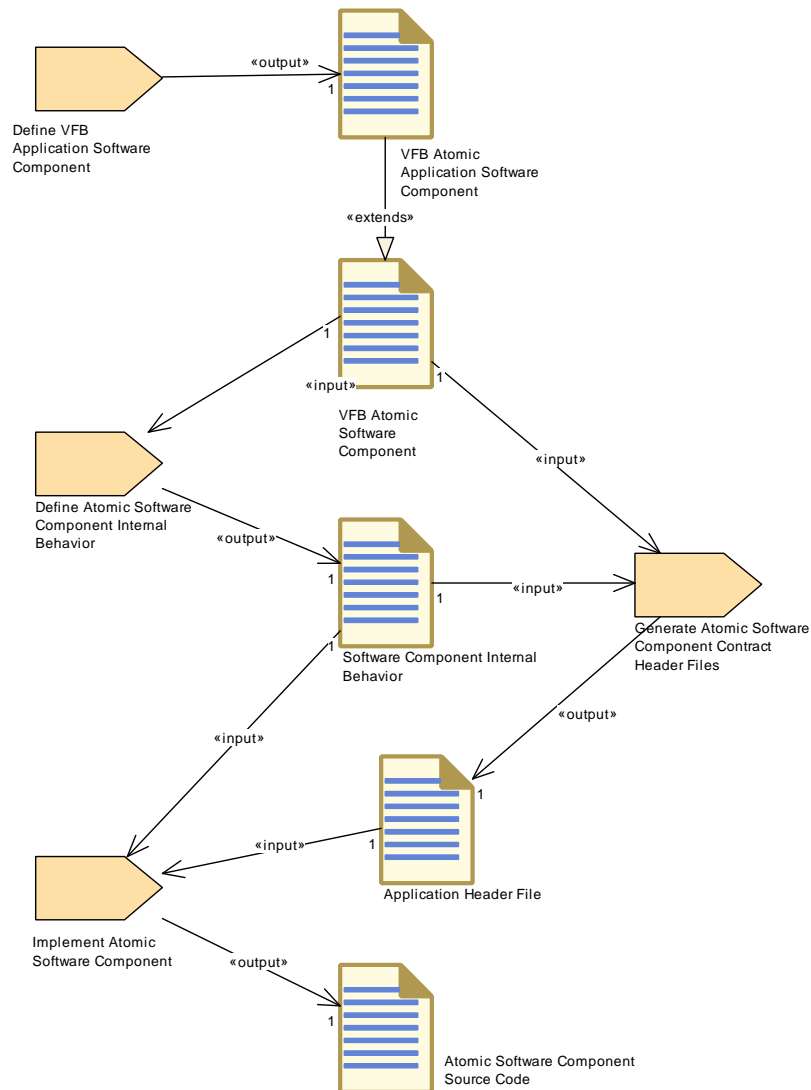
Figure 2.45 shows the work sequence assumed for this use case. The next two figures 2.46 and 2.47 show the tasks and work products of the method library involved in the activities on the VFB and Component resp. the ECU level.



**Figure 2.45: Use Case: Components and Services**

<b>Process Pattern</b>	<b>Components and Services</b>		
<b>Package</b>	AUTOSAR Root::M2::Methodology::Methodology Use Cases::High Level::Components and Services		
<b>Brief Description</b>	This use case focuses on the activities required to use and configure AUTOSAR Services. It is therefore a subset of the overall use case (Methodology Overview).		
<b>Description</b>	<p>Atomic Software Components can use AUTOSAR Services. In order to do so, two things have to be defined: The ports which are to be connected to the Service during ECU integration and in addition the needs to configure the Service (for example NvM blocks or symbolic names for diagnostic events) from the perspective of the single Software Component.</p> <p>The service ports have impact on the component API just like any other port, so there is no difference between service ports and "normal" ports with respect to API generation.</p> <p>Afterwards the Application Software Components are mapped to an ECU and their description is put into the corresponding ECU extract (deliverable Complete ECU Description). These activities belong to the system domain and are not explicitly shown in this use case (see Methodology Overview).</p> <p>As part of the ECU integration, additional artifacts are generated to connect the service ports over the RTE: Service Component Descriptions, including their mapping to the Basic Software Modules, and the connectors between their ports and the service ports of the Application Software Components.</p> <p>The ECU configuration of the Basic Software Module (e.g. DEM, DCM, Watchdog Manager etc.) is then created with respect to the service ports and the ServiceNeeds of the Application Software Components connected to that Service.</p>		
<b>Relation Type</b>	<b>Related Element</b>	<b>Mul.</b>	<b>Note</b>
Aggregates	<a href="#">Add Service Ports and Service Needs</a>	1	
Aggregates	<a href="#">Connect and Configure Service Module on ECU</a>	1	

**Table 2.34: Components and Services**

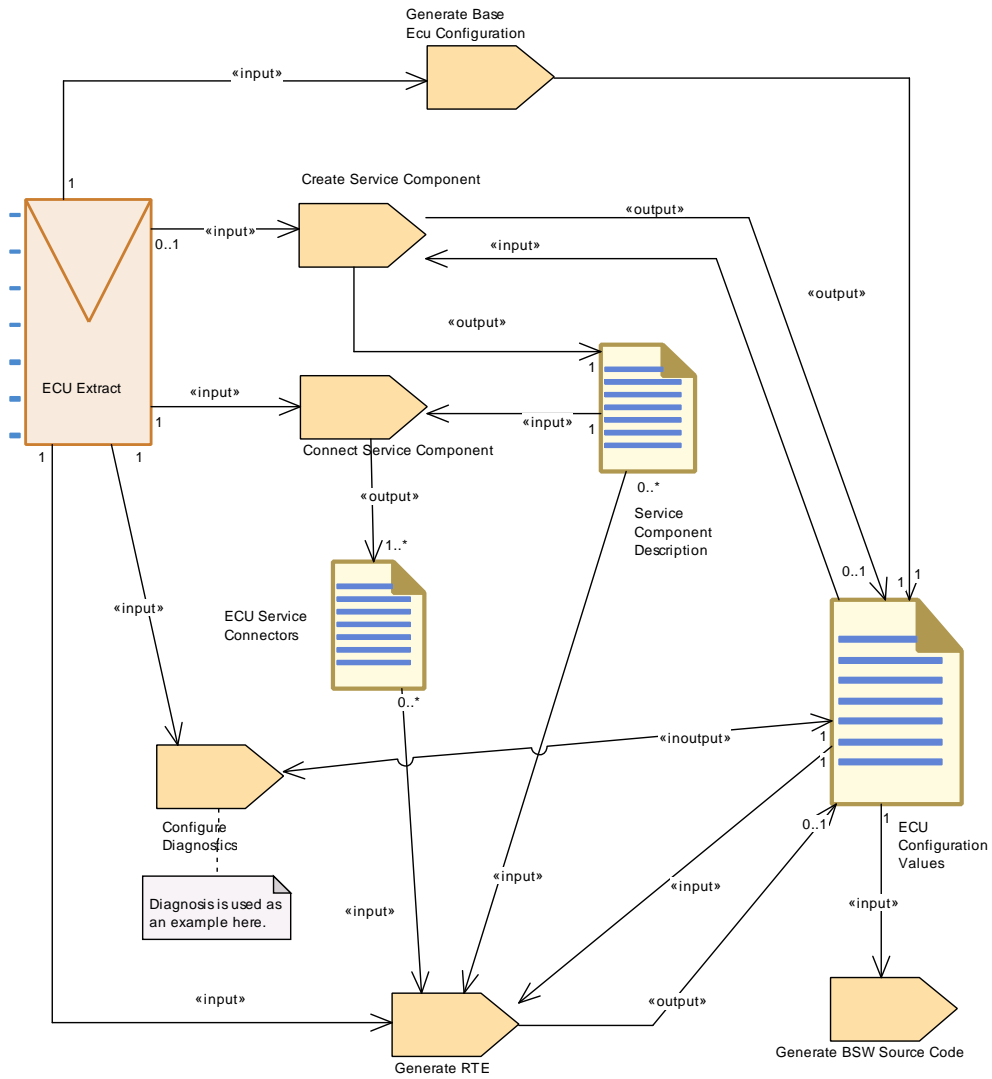


**Figure 2.46: Add Service Ports and Service Needs - Detailed view with work products**



<b>Activity</b>	<b>Add Service Ports and Service Needs</b>		
<b>Package</b>	AUTOSAR Root::M2::Methodology::Methodology Use Cases::High Level::Components and Services		
<b>Brief Description</b>			
<b>Description</b>	<p>Atomic Software Components can use AUTOSAR Services. In order to do so, two things have to be defined:</p> <ul style="list-style-type: none"> <li>• The ports which are to be connected to the Service during ECU integration (this is a sub-task of Define VFB Application Software Component). The port interfaces used for service ports should be standardized.</li> <li>• The needs to configure the Service (for example NvM blocks or symbolic names for diagnostic events) from the perspective of the single Software Component (this is a sub-task of Define Atomic Software Component Internal Behavior)</li> </ul> <p>The service ports have impact on the component API just like any other port, so there is no difference between service ports and "normal" ports with respect to API generation.</p>		
<b>Relation Type</b>	<b>Related Element</b>	<b>Mul.</b>	<b>Note</b>
Aggregates	Define Atomic Software Component Internal Behavior	1	Add Service Needs to Atomic Component:
Aggregates	Define VFB Application Software Component	1	Add Service Ports to Atomic Software Component:
Aggregates	Generate Atomic Software Component Contract Header Files	1	Re-generate Contract Header Files with Service Interfaces:
Aggregates	Implement Atomic Software Component	1	Re-Implement Atomic Software Component with Service Ports:

**Table 2.35: Add Service Ports and Service Needs**



**Figure 2.47: Connect and Configure Service Module on ECU - Detailed view with work products**

<b>Activity</b>	<b>Connect and Configure Service Module on ECU</b>		
<b>Package</b>	AUTOSAR Root::M2::Methodology::Methodology Use Cases::High Level::Components and Services		
<b>Brief Description</b>			
<b>Description</b>	<p>As part of the ECU integration, additional artifacts are generated to connect the service ports over the RTE: Service Component Descriptions, including their mapping to the Basic Software Modules, and the connectors between their ports and the service ports of the Application Software Components.</p> <p>The ECU configuration of the Basic Software Module (e.g. DEM, DCM, Watchdog Manager etc.) is then created with respect to the service ports and the ServiceNeeds of the Application Software Components connected to that Service (the diagram shows only the configuration activity of diagnostics as an example). The code generation of the service module (e.g. DEM, DCM) and of the RTE is shown for completeness.</p>		
<b>Relation Type</b>	<b>Related Element</b>	<b>Mul.</b>	<b>Note</b>
Aggregates	Create Service Component	1	
Aggregates	Generate BSW Source Code	1	
Aggregates	Generate Base Ecu Configuration	1	
Aggregates	Generate RTE	1	
Predecessor	Add Service Ports and Service Needs	1	

**Table 2.36: Connect and Configure Service Module on ECU**

## 2.9 Calibration Overview

### 2.9.1 Purpose

This use case describes the typical activities required from the creation or update of calibration parameters down to the creation or update of the [A2L Files](#).

### 2.9.2 Description

The use cases assumes, that calibration parameters are changed in an already existing system, thus the tasks required to define and build a new system are omitted, only the calibration relevant steps are shown.

In addition, the use case includes the (optional) task of updating a set of calibration parameter values as input for the RTE.

As far as AUTOSAR artifacts are involved, this use case can be divided into four major activities:

**[TR\_METH\_02001] Define Cross-component Calibration Parameters activity** [ [Define Cross-component Calibration Parameters](#): Contains the tasks used to define or update cross-component calibration parameters. These parameters have to be provided via ports by `Parameter Components`. ]([RS\\_METH\\_00002](#))

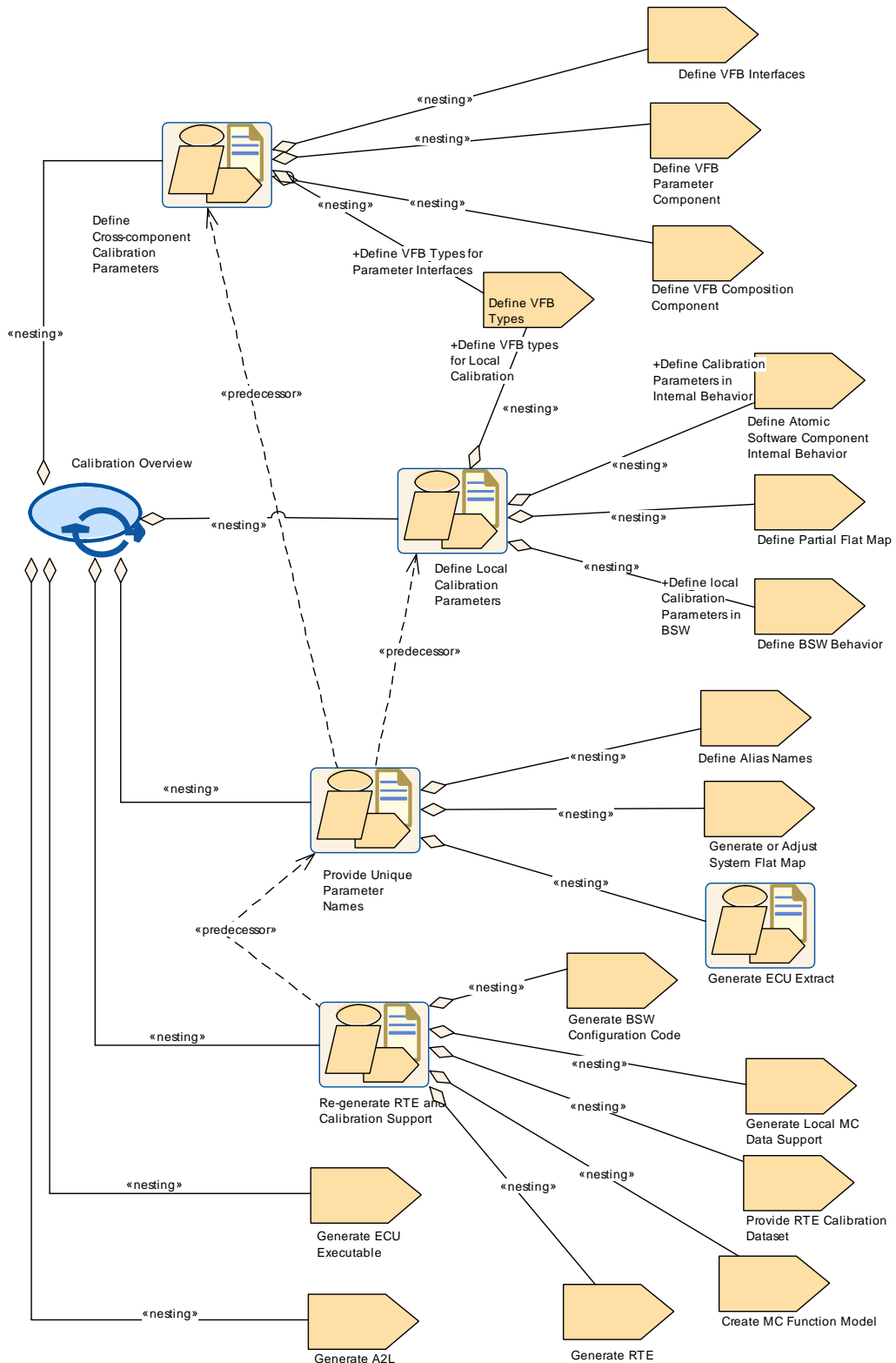
**[TR\_METH\_02002] Define Local Calibration Parameters activity** [ [Define Local Calibration Parameters](#): Contains the tasks used to define or update component-local calibration parameters or calibration parameters defined within a BSW module. These parameters are declared within the `Internal Behavior` of the component (or the BSW module) which uses them. ]([RS\\_METH\\_00002](#), [RS\\_METH\\_00003](#))

**[TR\_METH\_02003] Provide Unique Parameter Names activity** [ [Provide Unique Parameter Names](#): Contains the tasks used to provide unique names for calibration parameters. A `Flat Map` is used to provide unique names for MCD tools. An `Alias Name Set` can be provided additionally in cases, where this is not sufficient. ]([RS\\_METH\\_00005](#))

**[TR\_METH\_02004] Re-generate RTE and Calibration Support activity** [ [Re-generate RTE and Calibration Support](#): Contains the tasks used to re-generate relevant artifacts during ECU integration (before the final build) after an update of calibration parameters. ]([RS\\_METH\\_00020](#))

### 2.9.3 Workflow

Figure [2.48](#) shows the work sequence assumed for this use case.



**Figure 2.48: Use Case: Calibration Overview**

<b>Process Pattern</b>	<b>Calibration Overview</b>		
<b>Package</b>	AUTOSAR Root::M2::Methodology::Methodology Use Cases::High Level::Calibration Overview		
<b>Brief Description</b>	Describe the required steps to update the calibrations data down to an update of the A2L files.		
<b>Description</b>	<p>This use case shows the typical steps required from an updated design of calibration data down to an update of the A2L file. The use cases assumes, that calibration parameters are changed in an already existing system, thus the steps required to define and build a new system are omitted, only the calibration relevant steps are shown.</p> <p>In addition, the use case includes the (optional) task of updating a set of calibration parameter values as input for the RTE.</p>		
<b>Relation Type</b>	<b>Related Element</b>	<b>Mul.</b>	<b>Note</b>
Aggregates	Define Cross-component Calibration Parameters	1	
Aggregates	Define Local Calibration Parameters	1	
Aggregates	Generate A2L	1	
Aggregates	Generate ECU Executable	1	
Aggregates	Provide Unique Parameter Names	1	
Aggregates	Re-generate RTE and Calibration Support	1	

**Table 2.37: Calibration Overview**

<b>Activity</b>	<b>Define Cross-component Calibration Parameters</b>		
<b>Package</b>	AUTOSAR Root::M2::Methodology::Methodology Use Cases::High Level::Calibration Overview		
<b>Brief Description</b>			
<b>Description</b>	Contains the tasks used to define or update cross-component calibration parameters. These parameters are provided by Parameter Components.		
<b>Relation Type</b>	<b>Related Element</b>	<b>Mul.</b>	<b>Note</b>
Aggregates	Define VFB Composition Component	1	
Aggregates	Define VFB Interfaces	1	
Aggregates	Define VFB Parameter Component	1	
Aggregates	Define VFB Types	1	Define VFB Types for Parameter Interfaces: Use this task to define VFB Types for Parameter Interfaces

**Table 2.38: Define Cross-component Calibration Parameters**

<b>Activity</b>	<b>Define Local Calibration Parameters</b>		
<b>Package</b>	AUTOSAR Root::M2::Methodology::Methodology Use Cases::High Level::Calibration Overview		
<b>Brief Description</b>			
<b>Description</b>	Contains the tasks used to define or update component-local (or module-local) calibration parameters. These parameters are declared within the Internal Behavior of the component (or BSW module) which uses them.		
<b>Relation Type</b>	<b>Related Element</b>	<b>Mul.</b>	<b>Note</b>
Aggregates	Define Atomic Software Component Internal Behavior	1	Define Calibration Parameters in Internal Behavior: Use this task to define local calibration parameters as part of the Internal Behavior of a software component.
Aggregates	Define BSW Behavior	1	Define local Calibration Parameters in BSW: Use this task to define local calibration parameters as part of the Internal Behavior of a BSW module.
Aggregates	Define Partial Flat Map	1	Define (optionally) a Partial Flat Map for one or more delivered components.
Aggregates	Define VFB Types	1	Define VFB types for Local Calibration: Use this task to define VFB types for Local Calibration.

**Table 2.39: Define Local Calibration Parameters**

<b>Activity</b>	<b>Provide Unique Parameter Names</b>		
<b>Package</b>	AUTOSAR Root::M2::Methodology::Methodology Use Cases::High Level::Calibration Overview		
<b>Brief Description</b>			
<b>Description</b>	Contains the tasks used to provide unique names for calibration parameters. A Flat Map is used to provide unique names for MCD tools. An Alias Name Set can be provided in cases, where this is not sufficient.		
<b>Relation Type</b>	<b>Related Element</b>	<b>Mul.</b>	<b>Note</b>
Aggregates	Define Alias Names	1	
Aggregates	Generate ECU Extract	1	Use this activity to update the ECU Extract. This includes updating the ECU Flat Map if parameter names on ECU level have changed.
Aggregates	Generate or Adjust System Flat Map	1	Use this task if parameter names are defined on system level.
Predecessor	Define Cross-component Calibration Parameters	1	
Predecessor	Define Local Calibration Parameters	1	

**Table 2.40: Provide Unique Parameter Names**

<b>Activity</b>	<b>Re-generate RTE and Calibration Support</b>		
<b>Package</b>	AUTOSAR Root::M2::Methodology::Methodology Use Cases::High Level::Calibration Overview		
<b>Brief Description</b>			
<b>Description</b>	Contains the tasks used to re-generate relevant artifacts during ECU integration (before the final build) after an update of calibration parameters.		
<b>Relation Type</b>	<b>Related Element</b>	<b>Mul.</b>	<b>Note</b>
Aggregates	<a href="#">Create MC Function Model</a>	1	<p>This use case shows the creation of an MC Function Model as part of the activity that generates also the RTE and calibration support data.</p> <p>This is only one possibility. It is also possible to create an MC Function Model earlier in the process (as part of the design activities) or later (shortly before the A2L is generated).</p>
Aggregates	<a href="#">Generate BSW Configuration Code</a>	1	<p>Use this task to generate the description of calibration parameters in BSW that are a result of ECU configuration.</p> <p>Such parameters will be described within the artifact BSW Module Behavior Extension.</p>
Aggregates	<a href="#">Generate Local MC Data Support</a>	1	Use this task to generate support for calibration data that are not handled via the RTE.
Aggregates	<a href="#">Generate RTE</a>	1	<p>Use this task to generate support for calibration data that are handled over the RTE.</p> <p>This includes cross-component calibration as well as local calibration (in SWC and BSW) that needs emulation support by the RTE.</p>
Aggregates	<a href="#">Provide RTE Calibration Dataset</a>	1	
Predecessor	<a href="#">Provide Unique Parameter Names</a>	1	

**Table 2.41: Re-generate RTE and Calibration Support**

## 2.10 Memory Mapping

### 2.10.1 Purpose

This use case gives a comprehensive view on the tasks required to define, configure and generate header files for memory mapping and for the compiler abstraction related to memory aspects. The underlying concepts are specified in [8] and [9].



## 2.10.2 Description

**[TR\_METH\_02005] Memory sections for data and code** [ AUTOSAR basic software as well as application software use a standardized preprocessor mechanism in order to define memory sections for their data and code as well as compiler memory classes<sup>2</sup> defined globally or per section. The goal of this mechanism is to maintain the compiler specific statements and the ECU specific mappings separately from the main code. ]([RS\\_METH\\_00002](#), [RS\\_METH\\_00003](#), [RS\\_METH\\_00004](#), [RS\\_METH\\_00038](#))

With AUTOSAR it is possible to derive (i.e. generate) the content of these header files from XML artifacts. This use case shows how the required artifacts and tasks are related.

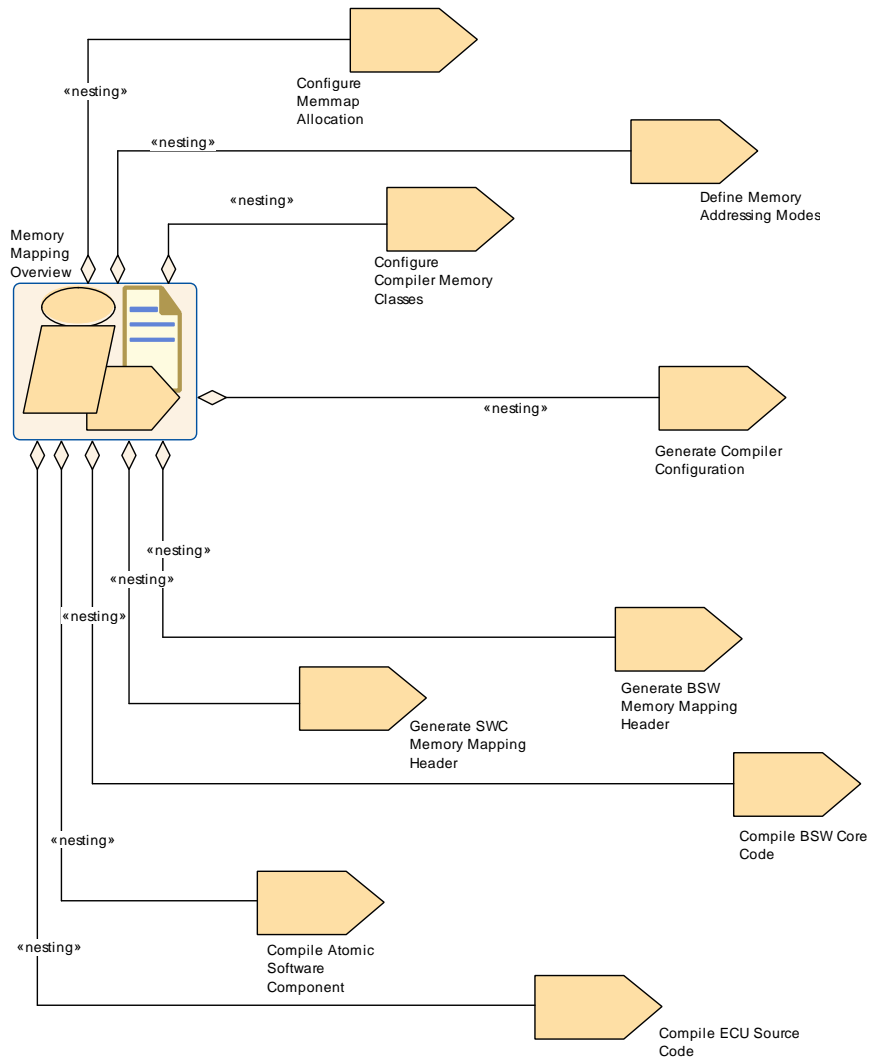
## 2.10.3 Workflow

Figure 2.49 shows the work sequence assumed for this use case. The next figures 2.50 and 2.51 show the involved tasks and work products of the method library.

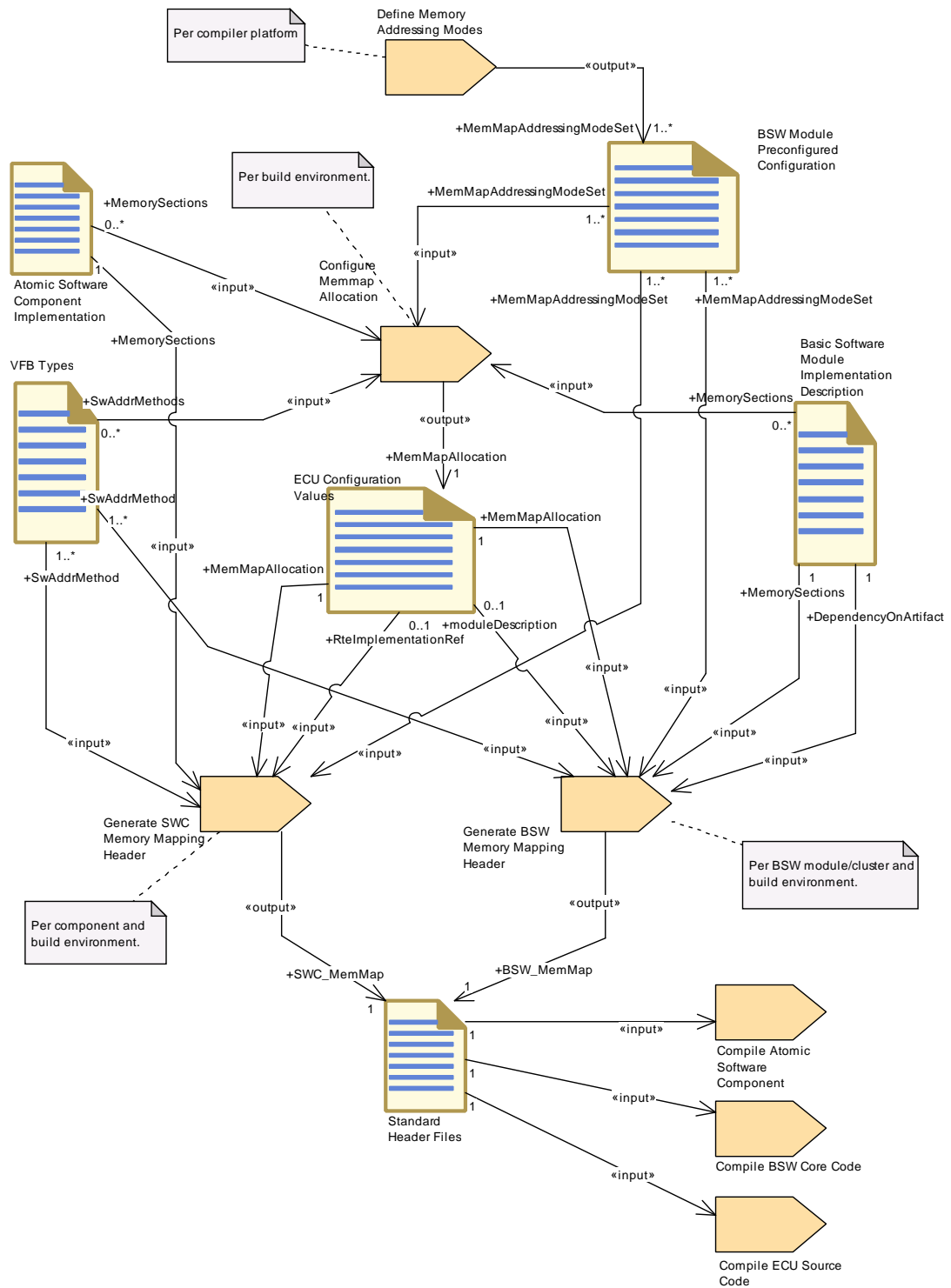
Note that this use case ends with compilation of the code. The assignment of memory sections to the actual hardware (which is typically done by the configuration of the linker) is currently not considered to be part of the AUTOSAR methodology.

---

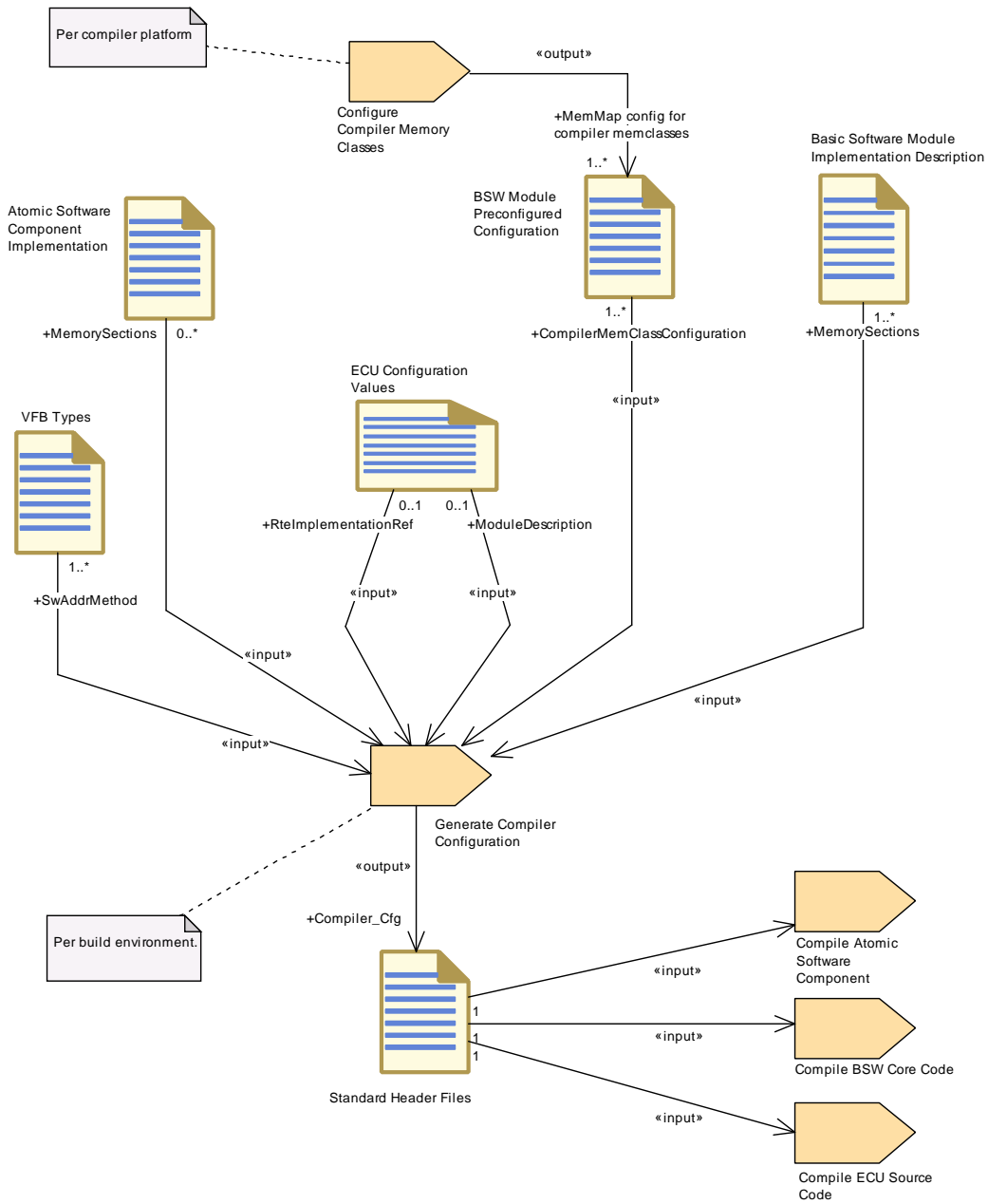
<sup>2</sup>This determines far and near addressing on certain platforms.



**Figure 2.49: Use Case: Memory Mapping**



**Figure 2.50: Memory Mapping - Detailed view with work products**



**Figure 2.51: Compiler Configuration - Detailed view with work products**

Activity	Memory Mapping Overview			
Package	AUTOSAR Root::M2::Methodology::Methodology Use Cases::High Level::Memory Mapping Overview			
Brief Description				
Description	Overview of the work sequence for defining and configuration of memory sections.			
Relation Type	Related Element	Mul.	Note	
Aggregates	Compile Atomic Software Component	1		
Aggregates	Compile BSW Core Code	1		

<i>Relation Type</i>	<i>Related Element</i>	<i>Mul.</i>	<i>Note</i>
Aggregates	Compile ECU Source Code	1	
Aggregates	Configure Compiler Memory Classes	1	
Aggregates	Configure Memmap Allocation	1	
Aggregates	Define Memory Addressing Modes	1	
Aggregates	Generate BSW Memory Mapping Header	1	
Aggregates	Generate Compiler Configuration	1	
Aggregates	Generate SWC Memory Mapping Header	1	

**Table 2.42: Memory Mapping Overview**

## 2.11 E2E Protection

### 2.11.1 Purpose

This `Activity` provides a rough outline of the creation of `E2E Protection` to secure communication flow in an AUTOSAR Architecture. [10]

### 2.11.2 Description

`E2E Protection` mechanisms are needed when safety related data exchanges need to be protected at runtime against communication link faults.

**[TR\_METH\_02006] E2E Protection** [ The `E2E Protection` in AUTOSAR is a protection wrapper over communication at the level of `SW Components` or at the level of `COM I-PDUs`, in both cases using a so-called `E2E library`. This safety wrapper can be implemented either into the `SW Components` (only for sender-receiver communication) or at the level of the `COM I-PDUs` when the integrity of operation of `COM` and `RTE` is provided. ]([RS\\_METH\\_00002](#), [RS\\_METH\\_00005](#))

For a better understanding this use case is splitted into two sub-activities:

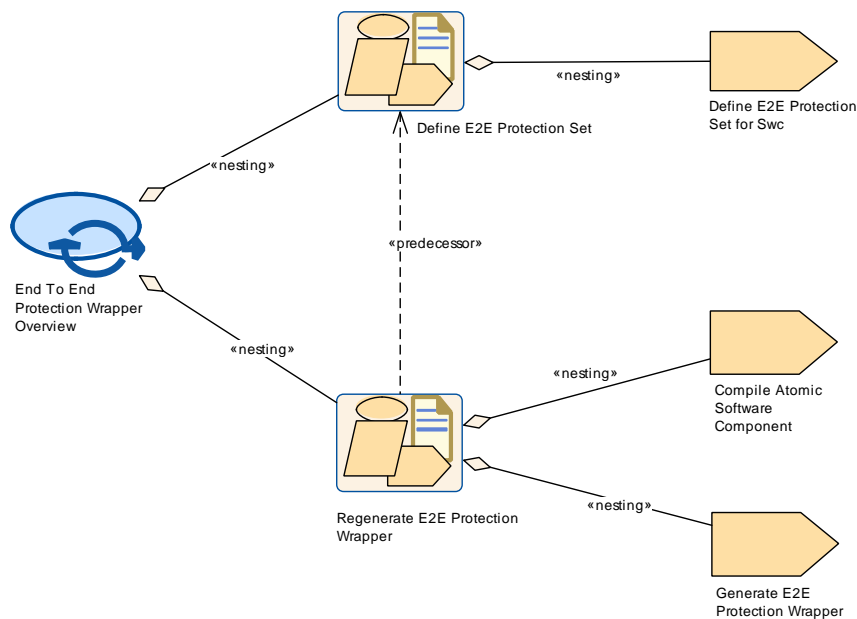
- [Define E2E Protection Set](#)
- [Regenerate E2E Protection Wrapper](#)

**[TR\_METH\_02007] Define E2E Protection Set activity** [ The activity *Define E2E Protection Set* is needed to define all information needed at run time for the E2E Protection wrapper like pre-defined Profiles configuration used in the E2E library with their corresponding Functions Parameters. ]([RS\\_METH\\_00002](#), [RS\\_METH\\_00005](#))

**[TR\_METH\_02008] Regenerate E2E Protection Wrapper activity** [ The activity *Regenerate E2E Protection Wrapper* is describing the generation and implementation of the E2E Wrapper at the SW Component level using the *E2E Protection Set*, the *Software Component Internal Behavior* and the overall *VFB System* information. ]([RS\\_METH\\_00002](#), [RS\\_METH\\_00005](#))

### 2.11.3 Workflow

Figure 2.52 shows the work sequence for this use case.



**Figure 2.52: End To End Protection Overview**

<b>Process Pattern</b>	<b>End To End Protection Wrapper Overview</b>		
<b>Package</b>	AUTOSAR Root::M2::Methodology::Methodology Use Cases::High Level::End To End Protection Wrapper Overview		
<b>Brief Description</b>			
<b>Description</b>			
<b>Relation Type</b>	<b>Related Element</b>	<b>Mul.</b>	<b>Note</b>
Aggregates	<a href="#">Define E2E Protection Set</a>	1	
Aggregates	<a href="#">Regenerate E2E Protection Wrapper</a>	1	

**Table 2.43: End To End Protection Wrapper Overview**

<b>Activity</b>	<b>Define E2E Protection Set</b>		
<b>Package</b>	AUTOSAR Root::M2::Methodology::Methodology Use Cases::High Level::End To End Protection Wrapper Overview		
<b>Brief Description</b>			
<b>Description</b>	This activity defines all constraints at the data level needed to generate the End to End wrapper. This set is based on different profiles for different levels of safe communication.		
<b>Relation Type</b>	<b>Related Element</b>	<b>Mul.</b>	<b>Note</b>
Aggregates	<a href="#">Define E2E Protection Set for Swc</a>	1	

**Table 2.44: Define E2E Protection Set**

<b>Activity</b>	<b>Regenerate E2E Protection Wrapper</b>		
<b>Package</b>	AUTOSAR Root::M2::Methodology::Methodology Use Cases::High Level::End To End Protection Wrapper Overview		
<b>Brief Description</b>			
<b>Description</b>	Regenerate or generate End to End protection wrapper. This generation is made at the SW Component level taking in account the Protection Set, the SWC Internal Behavior and the overall VFB System information.		
<b>Relation Type</b>	<b>Related Element</b>	<b>Mul.</b>	<b>Note</b>
Aggregates	<a href="#">Compile Atomic Software Component</a>	1	
Aggregates	<a href="#">Generate E2E Protection Wrapper</a>	1	
Predecessor	<a href="#">Define E2E Protection Set</a>	1	

**Table 2.45: Regenerate E2E Protection Wrapper**

## 2.12 Variant Handling

### 2.12.1 Overview

**[TR\_METH\_02009] Variation points in Variant Handling** [ Variant Handling for AUTOSAR is defined in the Generic Structure Template Template [11]. First, this concept defines means to designate certain locations in the AUTOSAR meta-model as *variation points*. A point roughly consists of a condition (under which conditions is this variation active?) and a binding time (when should this variation be resolved?). ]

Second, there are *predefined variants*.

**[TR\_METH\_02010] Predefined variants in Variant Handling** [ A typical AUTOSAR model may contain a large number of variation points. However, usually only a relatively small number of variants (i.e., combinations of “active” variation points) is actively used. Each predefined variant describes such a variant. ]

## 2.12.2 Binding Times

**[TR\_METH\_02011] Types of binding times** [ The AUTOSAR variant handling defines two kinds of binding times for AUTOSAR: the *latest binding time* and the *actual binding time*. They have the same kinds of values<sup>3</sup>, but are used in different contexts. ]([RS\\_METH\\_00074](#))

AUTOSAR defines the following binding times (presented here in chronological order):

- `BlueprintDerivationTime`
- `SystemDesignTime`
- `CodeGenerationTime`
- `PreCompileTime`
- `LinkTime`
- `PostBuild`

The Generic Structure Template mentions two more binding times. First, there is `FunctionDesignTime`, which comes before `SystemDesignTime`, but is independent of `BlueprintDerivationTime`. Second, there is `Runtime`, which comes after `PostBuild`. These binding times are not covered by AUTOSAR and mentioned here only for completeness.

**[TR\_METH\_02012] Definition of a binding time** [ It should also be noted that a binding “time” is not really a point in time, but rather denotes a phase in the development of an AUTOSAR system. ]([RS\\_METH\\_00074](#))

### 2.12.2.1 Latest Binding Time

**[TR\_METH\_02013] Latest Binding Time** [ In the AUTOSAR meta model, every variation point has a latest binding time, which is implemented by the tag `Vh.LatestBindingTime`. As the name suggests, the latest binding time of a particular variation point puts an upper limit on *when* this point can be bound. A variation may be bound earlier than this time, but not later. ]([RS\\_METH\\_00074](#))

For example, the latest binding time for a software component which is part of a composition is `PostBuild`. In other words, an ECU can be configured to decide at startup whether a software component is active or not.

However, it is not always possible to bind a variant at the latest *possible* time. To continue the above example, making all software components `PostBuild` means that an executable always contains code and other resources for all software components, regardless whether it gets activated or not. Because of this, it may happen that the

---

<sup>3</sup>`BlueprintDerivationTime` and `PostBuild` are not part of the actual enum that is used in the meta-model, but they are implied by the structure of the variation point. See chapter 7 in the Generic Structure Template Template [11] are more details.



executable becomes too large to fit onto its designated ECU. If this is the case, the software component needs to be bound earlier, typically at `PreCompileTime` or even at `SystemDesignTime`.

This is not the only scenario that leads to this decision. For example, a software component might contain two or more subcomponents each of which is specific to a certain vendor. In this case, before delivering the software component to a specific vendor, it is custom to remove the subcomponents that are targeted at the other vendor(s). This can obviously be done at `PrecompileTime` the latest.

There are also cases where there is an implicit (i.e., not stated of the meta-model) lower limit for the binding time of a variation point. For example, if a variant in software component *A* uses a variant in software component *B*, then the binding times need to be coordinated. Component *A* cannot be `SystemDesignTime` if component *B* is `PostBuild`, but makes use of software component *A*.

### 2.12.2.2 Actual Binding Time

**[TR\_METH\_02014] Actual Binding Time** [ This brings us to the actual binding time of a variation point, which is stored in an attribute<sup>4</sup> of the variation point. Again, it is not mandatory that the variation point is bound exactly at this stage; it rather states that the variation point must not be bound at a later stage.

This binding time may be earlier than the latest binding time. ]([RS\\_METH\\_00074](#))

As explained in the previous section, composition of software components can be bound at `PostBuild`, but it is not always desirable or even feasible to do so. In such a case, `bindingTime` should state an earlier binding time.

Also, unlike the latest binding time, which is a *meta model* element and is stated on M2 level, this binding time is a *model* element associated with a variation point and is stated on M1 level.

That is, the binding time of a variation point limits the point at which a *particular* variation point has to be bound, but this binding time is again constrained by the *latest binding time*.

### 2.12.3 Defining Variants

**[TR\_METH\_02015] Definition of variants** [ A variant is almost always more than a single variant point or a single system constant. Typically, a variant is a list of value assignments to system constants or postbuild variant conditions. In an AUTOSAR model,

---

<sup>4</sup>The attribute is named `bindingTime` and is located at the `ConditionByformula` element of a variation point. For an `AttributeValueVariationPoint`, it is contained in the attribute `bindingTime`.

such a list is represented by an instance of the meta-class `PredefinedVariant`, see definition of artifact `Predefined Variant`. [\]\(RS\\_METH\\_00005\)](#)

**[TR\_METH\_02016] Evaluated Variant Set** [ Similarly, an instance of the meta-class `EvaluatedVariantSet` is a set of `PredefinedVariants` that are known to work (or not to work) for a certain element of the meta-model, for example a specific software component. Evaluated variants may be used to exchange information about known variants between different vendors, for example to document which variants of a software component have been tested and are known to work.

In the Methodology SPEM model, the variant selectors are represented by the `Evaluated Variant Set` artifact which is created by the `Evaluate Variant` task. [\]\(RS\\_METH\\_00005, RS\\_METH\\_00075, RS\\_METH\\_00076\)](#)

This information is necessary because there is a extremely high number of *possible* variants, but only a very small subset of them are feasible.

**[TR\_METH\_02017] Use of Predefined Variant** [ The set of system constants that are contained in an instance of `PredefinedVariant` usually affect a number of variation points, which are at different locations in the model and have different binding times.

Hence, a predefined variant cannot be directly associated with a specific location in the meta-model, or a certain binding time. On the contrary, a `PredefinedVariant` is used for several meta-model elements and at different binding times. [\]\(RS\\_METH\\_00005, RS\\_METH\\_00076\)](#)

#### 2.12.4 Choosing Variants

Whether a variation point is included in a system or not is determined by one or more variables. If the binding time of a variation point is anywhere from `SystemDesignTime` to `LinkTime`, then the variation point contains an expression that is based on system constants (see artifact `System Constant Value Set`). If this expression evaluates to true, then the variation point is included in the system. `PostBuild` uses a simplified scheme that allows only a single comparison with a `PostBuildVariantCriterion` (technically, an `ARElement`).

**[TR\_METH\_02018] Choosing variants** [ So, a variant is *chosen* as soon as the values for the respective system constants or postbuild variant conditions have been determined. This is usually done by selecting a `PredefinedVariant`, which contains the respective values. This selection must obviously happen before a variation point is bound. But, it does not need to happen *immediately* before a variation point is bound. [\]\(RS\\_METH\\_00005\)](#)

For example, the system constants that determine a `PreCompileTime` variation point may already have been chosen at `SystemDesignTime`, but the actual binding has to be delayed to `PreCompileTime` because of a dependency on another software

components that have the binding time `PreCompileTime`, as described in Section 2.12.2.2.

Furthermore, since `PredefinedVariant` spans several variation points, which may have different binding times, some might have a binding time (latest or even actual) immediately after the `PredefinedVariant` has been chosen, and the others might have a later binding time.

Finally, the decision to go for a particular variant is often tied to vendor specific processes that follow their own timeline.

Hence, the time at which a particular variant is chosen is often not the same as the time when the associated variation points are bound. In summary, a variant must be chosen some time before it is bound, but the actual time when this is happening is not determined by AUTOSAR, and is also quite vendor specific.

## 2.13 Definition of Binding Times

### 2.13.1 Overview

A binding time is not (as the name probably suggests) a precise point in time, but rather a classification of processing steps. For example, the binding time `CodeGenerationTime` refers to a transformation step from an *AUTOSAR model* in ARXML format to *code*.

In this section, we define binding times for artifacts and tasks in the methodology.

**[TR\_METH\_00001] Definition of Binding Time for Tasks** [ A task has binding time  $X$  if it binds variation points of binding time  $X$ .

This means in particular:

- Any task that works on the model *may* bind variation points that have the binding time `SystemDesignTime`.
- Any task that *generates* code needs to bind open variation points that have the binding time `CodeGenerationTime`. All variation points with earlier binding times must have been bound by then.
- Similarly, any task that *compiles* code needs to bind open variation points that have the binding time `PreCompileTime`.<sup>5</sup> All variation points with earlier binding times must have been bound by then.

---

<sup>5</sup>Note that in case of the RTE code, the technical step of binding `PreCompileTime` variants is partially done by a preparatory task which runs before the actual compilation, see [Generate RTE Prebuild Dataset](#). That means in particular, the relevant system constants must be defined before executing this preparatory task. The binding time of actual compilation task [Compile ECU Source Code](#) is indicated as `CompileTime` in this case.

At this time, the *values* for `PostBuildVariantConditions` of variation points must also be bound. These values have a latest binding time of `PreCompileTime`<sup>6</sup>.

In all these cases, the system constants that are needed by the condition of a variation point obviously must be defined before the variation point is bound.

In the Methodology library, the binding time of a task is indicated by a value of the tag `Meth.bindingTime` for those tasks which *always* can be associated with this binding time. It is *not* indicated for tasks that only optionally bind variations. This typically is the case for all tasks that only work on the ARXML model, for example, it is up to the concrete process whether a task like `Extract ECU Topology` shall bind any variations. [|\(RS\\_METH\\_00074, RS\\_METH\\_00075\)](#)

**[TR\_METH\_00002] Definition of Binding Time for Artifacts** [ In an artifact with binding time  $X$ , all variation points up to binding time  $X$  shall be bound.

We do not denote such a binding time for artifacts in the Methodology library, because their binding time typically depends on the context. However, this definition could be used to assign a binding time to an artifact as part of a specific use case. [|\(RS\\_METH\\_00074\)](#)

**[TR\_METH\_00003] Definition of Binding Time for Artifacts in the context of particular tasks** [ If an artifact of binding time  $X$  is used as input or output of a particular task, then all variation points *related to that task* with binding time up to  $X$  shall be bound.

This in particular means that if the artifact is input to the task, then binding time variation points  $X$  shall be bound and the task relies on this.

If the artifact is output to the task, it is granted that the such created artifact has all variation points of binding time  $X$  bound.

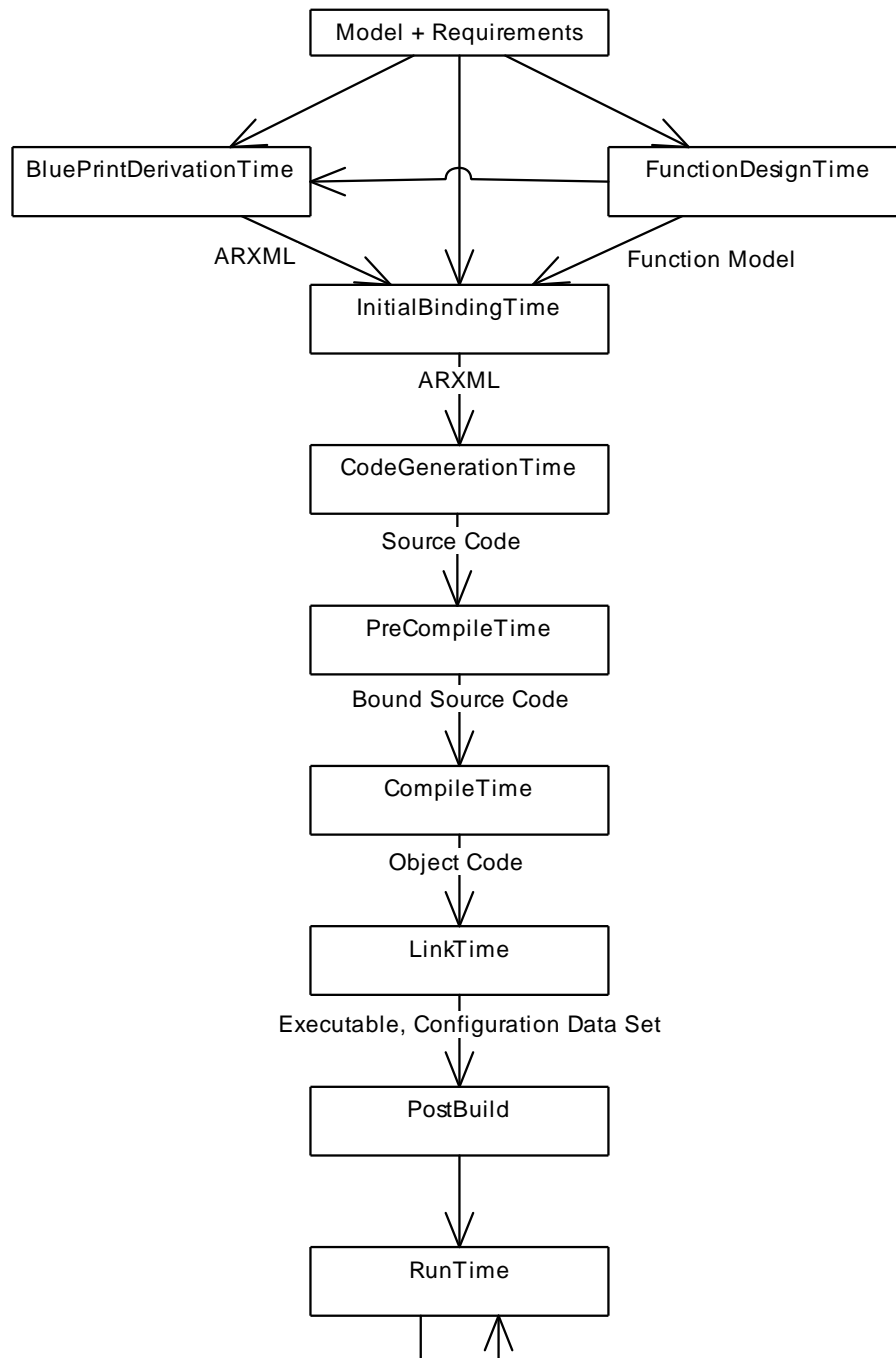
In the Methodology library, this is indicated by a value of the tag `Meth.bindingTime` attached to a `Consumes/ConsumedBy` resp. `Produces/ProducedBy` relationship.

Note that the tag `Meth.bindingTime` is not applicable to `inout` relationships, as the binding time values according to the above definition are usually different for the inputs and outputs of a particular task. If it is important to express these binding times, the `inout` relation must be split into an input (i.e. `ConsumedBy`) and output (i.e. `Produces`) relation. [|\(RS\\_METH\\_00074\)](#)

Figure 2.53 presents an overview of binding times as used in the AUTOSAR methodology. Boxed elements in this figure correspond to binding times, and the connections between them characterize artifacts.

---

<sup>6</sup>The variation point is still `PostBuild`: the `PostBuildVariantCondition` is fixed at `PreCompileTime`, but the comparison with the associated `PostBuildVariantCriterion` occurs at `PostBuildVariantCriterion`. See the Generic Structure Template [11] for details



**Figure 2.53: Overview of Binding Times**

### 2.13.2 A Classification of Artifacts with respect to Binding Times

**Model, Requirements, Functional Model** These refer to models that are not an *AUTOSAR Model*. For example, a *Model* may be a Matlab/Simulink model or a requirements document.

**ARXML** An *ARXML* artifact is a XML document that conforms to the AUTOSAR XML schema.

**Source Code** A *Source Code* artifact is text written using the syntax of a programming language, for example such as C or C++.

*Source Code* may be generated by hand, or may be the output of a code generator.

**Bound Source Code** A *Bound Source Code* artifact contains source code without any unbound precompile variation points.

**Object Code** An *Object Code* is the output of a compiler. Object code is typically machine code, but may also include descriptive information in a format such as XML.

**Executable** An *Executable* is an artifact that can run on an ECU. It is often similar to *Object Code*; the difference between the two is that the former does not provide means for execution on an ECU.

**Configuration Data Set** A *Configuration Data Set* is a set of assignments to `Post-BuildVariantCriterion`.

### 2.13.3 Classification of Binding Times

Table 2.46 presents an overview of the binding times in AUTOSAR Variant Handling.

Binding Time	AUTOSAR Metamodel	AUTOSAR Methodology
BlueprintDerivationTime	partially	yes
FunctionDesignTime	out of scope	out of scope
InitialBindingTime	no	yes
SystemDesignTime	yes	yes
CodeGenerationTime	yes	yes
PreCompileTime	yes	yes
CompileTime	unused	yes
LinkTime	yes	yes
PostBuild	yes	yes
Runtime	out of scope	out of scope

**Table 2.46: Binding Times in Meta Model and Methodology**

Variant handling in the AUTOSAR meta model supports the following binding times:

- BlueprintDerivationTime
- SystemDesignTime
- CodeGenerationTime
- PreCompileTime
- LinkTime

- `PostBuild`

**[TR\_METH\_02020] Definition of latest Binding Time for a variation point in the meta-model** [ All these binding times may be used in the tag `<<Vh.latestBindingTime>>`, which is used to define the latest binding time for a variation point in the meta model.

The actual binding time of a variation point is stored in the attribute `bindingTime` of the `ConditionByFormula` of a `VariationPoint`, and can only use the values `SystemDesignTime`, `CodeGenerationTime`, `PreCompileTime`, `LinkTime`.  
]([RS\\_METH\\_00074](#))

The AUTOSAR methodology utilizes two more binding times, `InitialBindingTimes` to characterize artifacts where no variation points are bound, and `CompileTime` to distinguish between preprocessing and compiling of code. Finally, `FunctionDesignTime` and `Runtime` are not in the scope of AUTOSAR variant handling but mentioned here for completeness.

### 2.13.3.1 `BlueprintDerivationTime`

At `BlueprintDerivationTime`, a model is derived from Blueprints. For example, a function design tool provides the option to derive objects from a predefined set of blueprints. See [12] for more details. This is different from the variant handling defined in this chapter, but it uses the same meta model features (see [11]).

`BlueprintDerivationTime` is out of the scope of this document, but mentioned here for completeness.

**Input Artifacts:** Model, Requirements

**Output Artifacts:** ARXML

### 2.13.3.2 `FunctionDesignTime`

At `FunctionDesignTime`, a software architecture independent model for (control) systems is developed. Typical tools used at this stage are *Matlab/Simulink*, or *ASCET-MD*.

If a function design tool supports variant handling according to AUTOSAR it has no other choice than using `CodeGenerationTime` or later as binding time in the generated AUTOSAR artifacts.

`FunctionDesignTime` is out of the scope of this document (as long as it does not affect calibration measurements), but mentioned here for completeness.

**Input Artifacts:** Model, Requirements

**Output Artifacts:** Function model

### 2.13.3.3 InitialBindingTime

At InitialBindingTime, no variation points are bound. This binding time is needed to express a state where no SystemDesignTime points are bound in artifact

**Input Artifacts:** Model, Requirements, Function model, AUTOSAR models from blueprints in ARXML format.

**Output Artifacts:** ARXML.

### 2.13.3.4 SystemDesignTime

SystemDesignTime is characterized by the following tasks:

- Designing the VFB
- Software Component types (Interfaces)
- SWC Prototypes and the Connections between SWCprototypes
- Designing the Topology
- ECUs and interconnecting Networks
- Designing the Communication Matrix and Data Mapping

**Input Artifacts:** Function model, Requirements, AUTOSAR models from blueprints in ARXML format.

**Output Artifacts:** ARXML.

### 2.13.3.5 CodeGenerationTime

At this step, code is generated. This may be done either by hand, or using a tool, or a mixture of both.

Handwritten code is typically based on a requirements document, whereas generated code is usually created from a model that was designed at FunctionDesignTime or SystemDesignTime.

Both the requirements and the model may contain variants, but code is only generated for those variants that have been selected, or which need to be resolved later.

**Input Artifacts:** ARXML.

**Output Artifacts:** Source Code.



### 2.13.3.6 PreCompileTime

At `PreCompileTime`, a preprocessor (e.g., the C preprocessor) is used to further customize the code and exclude parts of the code from the compilation process.

There are several reasons for such an exclusion: code is not required for the selected variant(s), code is incompatible with the selected variant(s), or code requires resources that are not present in the selected variant(s). The code that is excluded at this stage code will not be available at later stages.

`PreCompileTime` is typically used for handwritten code (for which `SystemDesignTime` and `CodeGenerationTime` obviously cannot not take effect) or when a system constant needs to be bound after code generation.

**Input Artifacts:** Source Code.

**Output Artifacts:** Bound Source Code.

### 2.13.3.7 CompileTime

At `CompileTime`, source code that has already been processed by a macro processor such as the C preprocessor and stripped of all `PreCompileTime` variation points is transformed into object code. The compiler might eliminate further variants by removing unused code paths.

`CompileTime` is not used in the AUTOSAR meta model, but is used in the AUTOSAR methodology to discriminate between a preprocessor and a compiler.

**Input Artifacts:** Bound Source Code.

**Output Artifacts:** Object code.

### 2.13.3.8 LinkTime

The configuration at this stage determines which modules are included in the resulting object code (executable), and which ones are omitted based on the selected variants.

**Input Artifacts:** Object code.

**Output Artifacts:** Executable program.

### 2.13.3.9 PostBuild

`PostBuild` is the binding time which is bound latest at startup of the ECU. In other words this is everything between creation of the executable program and startup of the ECU.

The startup of the ECU is the PostBuild binding since and obviously cannot be resolved in the model.

**Input Artifacts:** Executable program, Configuration data set.

**Output Artifacts:** –

### 2.13.3.10 Runtime

Everything after startup and initialization is `RunTime`. Variant Handling at `RunTime` is out of the scope of this document, but mentioned here for completeness.

## 2.14 How to resolve Name Conflicts

### 2.14.1 Reasons for Name Conflicts

In the highly distributed development of an AUTOSAR system, there is a certain risk that symbolic names used in different development artifacts are not unique so that name conflicts may occur when applying software tools.

**[TR\_METH\_03000] Name spaces via ARPackages** [ In the “upstream” specification of an AUTOSAR system, a software component, a basic software module or configuration parameters via `AUTOSAR XML` artifacts, such a risk can be widely avoided through the proper usage of `ARPackages` because they set up name spaces and may be nested (see also `General Autosar Artifact`). Here it is recommended to follow similar rules as AUTOSAR is using for its own published artifacts, see [11]: `[TPS_GST_00081]`, `[TPS_GST_00083]`, `[TPS_GST_00086]`. ] (`RS_METH_00002`, `RS_METH_00003`, `RS_METH_00004`, `RS_METH_00005`)

However, certain symbols specified in the `AUTOSAR XML` artifacts need to be transferred to other development artifacts in later process steps (“downstream”) and will appear e.g. as symbols in C-code, as file names, as names displayed by calibration tools or in textual documents. Here we have in general two reasons for naming conflicts (which may also occur in combination):

**[TR\_METH\_03001] Reasons for name conflicts in “downstream” artifacts** [

- **Uncoordinated co-development**

Due to the global name space of the C-language within one compilation unit, the risk of name conflicts is rather high if pieces of source code are integrated that were developed by different parties without coordinating the definition of symbols. The same can happen with names of header files or with symbols visible by the linker.

In AUTOSAR, the programming language interfaces between software components and (to some extend) between basic software modules are restricted to

certain patterns and are generated from ARXML, so the coordination effort is restricted to the proper definition of the relevant symbols in ARXML.

In several cases the `shortName` of an `ARElement` corresponds to an identifier in the code (or to a part of such an identifier), sometimes also to a file name or a part of it. Since `shortNames` are also used in the links between ARXML elements, it is hard to change such a name without impact on the overall design. This is for example the case for the names of the `AtomicSwComponentTypes`.

- **Multiple instantiation**

The AUTOSAR Runtime Environment (RTE) supports multiple instantiation of software components. This means, in a system and even on one ECU there can be several instances of a given `AtomicSwComponentType`. Each instance possesses its own data (managed by the RTE), but there is only one artifact ([VFB Atomic Software Component](#)) describing the whole type. If one needs a symbol identifying a particular component instance or particular data belonging to that instance (for example for display in a calibration tool), a conflict arises.

A similar thing happens with data elements or operation arguments in a `PortInterface` or in a composite data type, if the enclosing element is reused in more than one context.

A different kind of “multiple instantiation” can occur in the basic software, if several driver modules implement the same interface (only distinguished by an instance identifier). In this case, we actually have different implementations of code, the modules only share the upper levels of description (artifacts [Basic Software Module Description](#) and [Basic Software Module Internal Behavior](#)).

]([RS\\_METH\\_00038](#))

## 2.14.2 Points in the Methodology where Name Conflicts are resolved

On the other hand we have multiple points in the methodology where to resolve those conflicts.

In general we can distinguish between the development phase in which a name conflict is resolved and the phase in which it occurs (or would occur). Because a conflict usually prevents a certain task from being completed (e.g. compilation), it must be resolved in the same or an earlier phase than the phase in which it would occur.

- **[TR\_METH\_03002] Conflict solution at system design time** [ This is mentioned mainly for completeness. Of course, a proper system design can avoid conflicts in the first place and if a name conflict still arises in a later phase, it is in principle possible to iterate over the system design. But in this chapter we focus on solutions that allow to resolve name conflicts in later process phases which usually causes less effort.]([RS\\_METH\\_00006](#))

- **[TR\_METH\_03003] Conflict solution at coding time** [ Conflicts occurring at compile time or link time must be resolved (latest) at the time a developer is producing the code and/or the ARXML descriptions leading to the generation of code. In other words, this has to happen within the activities [Develop an Atomic Software Component](#) or [Develop BSW Module](#). Note that in the worst case, such a conflict is detected not before integration time (during activity [Build Executable](#)) which means that some kind of iteration of the activities is required.] ([RS\\_METH\\_00006](#))
- **[TR\_METH\_03004] Conflict solution at ECU integration time** [ During ECU integration time (latest) it is still possible to resolve name conflicts that would occur in tasks after the software build, e.g. during generation of A2L files.] ([RS\\_METH\\_00006](#))

### 2.14.3 Mechanisms for resolving Name Conflicts

The mechanisms to resolve the name conflicts are:

- **[TR\_METH\_03005] Conflict solution via SymbolProps** [

This mechanism allows to redefine a name in cases where the `shortName` by default is used to generate RTE relevant code. This avoids to change the overall design in the ARXML model.

This mechanism can be applied at coding time (activity [Develop an Atomic Software Component](#), task [Define SymbolProps for Types](#)) and solves conflicts caused by uncoordinated development. Such changes - even if they do not influence the overall design of the software - should be agreed upon by the involved parties.

This mechanism is provided for the following meta-model elements:

`AtomicSwComponentType.symbolProps`

Allows to redefine the software component type name that the RTE is using in its code. This resolves name clashes among different software component types designed accidentally with the same `shortName`.<sup>7</sup>

`ImplementationDataType.symbolProps`

Allows to redefine the implementation data type name used in the code of the RTE and/or the components. This resolves name clashes among different implementation data types designed accidentally with the same `shortName`.

For more information on the meta-model refer to [TPS\_SWCT\_01194] and [TPS\_SWCT\_01110] in [4].] ([RS\\_METH\\_00002](#))

---

<sup>7</sup>Note that this mechanism is not applicable for the prefixes used in the preprocessor code of memory sections and compiler memory classes. Conflicts among these preprocessor symbols due to duplicate component type names are not visible to the linker. However conflicts might occur when compiling the header file `Compiler_Cfg.h` and must be resolved manually.

- **[TR\_METH\_03006] Conflict solution via literal prefixes** [

This mechanism is similar to the one described before. It allows to define a prefix for preprocessor literals (e.g. for enumeration types or upper/lower limits) created by the RTE generator contract phase. Also this mechanism solves conflicts caused by uncoordinated development and must be applied at coding time (part of task [Define Atomic Software Component Internal Behavior](#)).

The model element to be manipulated is:

```
SwcInternalBehavior.includedDataSet.literalPrefix
```

For more information refer to [TPS\_SWCT\_01157] in [4].] ([RS\\_METH\\_00002](#))

- **[TR\_METH\_03007] Conflict solution in names of runnable entities** [

In case of a `RunnableEntity` the symbol used in the code is already independent from the `shortName` - it is always modeled via the attribute `RunnableEntity.symbol`. However, since these symbols need to be unique in the scope of one RTE instance (see [constr\_2025] in [4]), also here a name conflict can occur at integration time if the definition of the symbols was not coordinated before.

Similar to the cases discussed before, this conflict must be solved at coding time simply by changing the symbol. Note that such a change would not influence the overall design and can be done locally on one component (whose runnable shall be renamed) since the runnable symbol is hidden to other components by the RTE. Despite of that, the definition of unique runnable symbols still might need some human coordination.] ([RS\\_METH\\_00002](#))

- **[TR\_METH\_03008] Conflict solution via FlatMap** [

This mechanism allows to assign identifiers to instances of model elements (e.g. software component instances or data element instances) so that they are unique in a certain scope, e.g. a system or an ECU. Thereby name conflicts are avoided, which would occur if simply the `shortNames` of the ARXML elements would be used. In other words, this mechanism solves the name conflicts arising from multiple instantiation of types in the ARXML model.

The identifiers defined in this way are typically not used within the code, since AUTOSAR components do not rely on global variables. The main purpose is the usage within other artifacts which need to handle symbols out of the package context of the ARXML model, for example citation in documents (e.g. in artifact [Software Component Documentation](#)) or input for measurement and calibration tools (e.g. in artifact [RTE Measurement and Calibration Support Data](#)). A special use case of the [ECU Flat Map](#) is the model transformation from the System to ECU Extract, where it is used to define additional names of component prototypes.

The point in the methodology where this mechanism is applied depends of course on the use case. The typical tasks in the methodology library for defining a Flat Map are normally performed before integration time: [Generate or Ad-](#)

just [System Flat Map](#), [Define Partial Flat Map](#) and [Generate or Adjust ECU Flat Map](#). But since identifiers in a `FlatMap` are independent of the code, it can in principle be adjusted even at integration time in case a conflict occurs.

For more information see artifacts [System Flat Map](#), [Partial Flat Map](#) and [ECU Flat Map](#), for the underlying meta-model parts refer to refer to [6].] ([RS\\_METH\\_00005](#))

- **[TR\_METH\_03009] Conflict solution via `AliasNameSet`** [

This mechanism is similar to `FlatMap`. It allows to define additional names for model elements, either on top of an entry in a `FlatMap` or standalone. The usage is also similar, but there are no standardized use cases in connection with the AUTOSAR RTE. It can be used in cases where the format of the `FlatMap` is too restrictive.

For more information refer to the artifact [Alias Name Set](#) and task [Define Alias Names](#). For the meta-model of `AliasNameSet` refer to [6]. The document [6] also gives recommendations on how to transfer certain attributes below `AliasNameSet` into an ASAM ASAP2 (“A2L”) specification.]

- **[TR\_METH\_03010] Conflict solution via `API Infixes`** [

If several “instances” of a basic software module (with different implementation but identical interface definition) are linked together, name conflicts have to be solved by defining “infixes”. These are small pieces of strings denoting the module vendor and the instance role. They are used to extend globally visible C symbols and certain header file names. The mechanism is also relevant for the basic software scheduler APIs generated in task [Generate BSWM Contract Header Files](#).

Though this mechanism solves a conflict of a certain kind of multiple instantiation, it is relevant to the code and thus must be applied at coding time. The description of the infixes has to be put into the artifact [Basic Software Module Implementation Description](#).

For more information refer to [TPS\_BSWMDT\_04031] in [5] and to [SWS\_BSW\_00102] in [13].] ([RS\\_METH\\_00003](#))

## 3 Methodology Library

### 3.1 Common Elements

This chapter contains the definition of work products and tasks used in several areas of AUTOSAR development. For the definition of the relevant meta-model elements refer to [11].

#### 3.1.1 Work Product Kinds

<b>Category</b> <i>(Work Product Kind)</i>	<b>AUTOSAR XML</b>
<b>Package</b>	AUTOSAR Root::M2::Methodology::Methodology Library::Common Elements::Work Product Kinds
<b>Brief Description</b>	
<b>Description</b>	An artifact that conforms to the AUTOSAR XML schema.

**Table 3.1: AUTOSAR XML**

<b>Category</b> <i>(Work Product Kind)</i>	<b>Source Code</b>
<b>Package</b>	AUTOSAR Root::M2::Methodology::Methodology Library::Common Elements::Work Product Kinds
<b>Brief Description</b>	
<b>Description</b>	A human readable artifact that conforms to a defined programming language syntax, such as C or Java.

**Table 3.2: Source Code**

<b>Category</b> <i>(Work Product Kind)</i>	<b>Bound Source Code</b>
<b>Package</b>	AUTOSAR Root::M2::Methodology::Methodology Library::Common Elements::Work Product Kinds
<b>Brief Description</b>	
<b>Description</b>	A Bound Source Code artifact contains source code without any unbound precompile variation points.

**Table 3.3: Bound Source Code**

<b>Category</b> <i>(Work Product Kind)</i>	<b>Object Code</b>
<b>Package</b>	AUTOSAR Root::M2::Methodology::Methodology Library::Common Elements::Work Product Kinds
<b>Brief Description</b>	

<b>Description</b>	An Object Code is the output of a compiler. Object code is typically machine code, but may also include descriptive information in a format such as XML.
--------------------	--

**Table 3.4: Object Code**

<b>Category (Work Product Kind)</b>	<b>Configuration Data Set</b>
<b>Package</b>	AUTOSAR Root::M2::Methodology::Methodology Library::Common Elements::Work Product Kinds
<b>Brief Description</b>	
<b>Description</b>	This is a special kind of binary code containing configuration that can be loaded separately from the main ECU code.

**Table 3.5: Configuration Data Set**

<b>Category (Work Product Kind)</b>	<b>Executable</b>
<b>Package</b>	AUTOSAR Root::M2::Methodology::Methodology Library::Common Elements::Work Product Kinds
<b>Brief Description</b>	
<b>Description</b>	An Executable is an artifact that can run on an ECU. It is often similar to Object Code; the difference between the two is that the former does not provide means for execution on an ECU.

**Table 3.6: Executable**

<b>Category (Work Product Kind)</b>	<b>Text</b>
<b>Package</b>	AUTOSAR Root::M2::Methodology::Methodology Library::Common Elements::Work Product Kinds
<b>Brief Description</b>	
<b>Description</b>	A human readable artifact that is stored as plain text, rich text, PDF, etc.

**Table 3.7: Text**

<b>Category (Work Product Kind)</b>	<b>Custom</b>
<b>Package</b>	AUTOSAR Root::M2::Methodology::Methodology Library::Common Elements::Work Product Kinds
<b>Brief Description</b>	
<b>Description</b>	A custom artifact format which is not further specified in the AUTOSAR Methodology.

**Table 3.8: Custom**

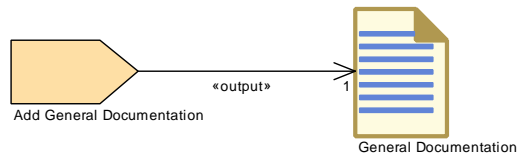


<b>Category (Work Product Kind)</b>	<b>Delivered</b>
<b>Package</b>	AUTOSAR Root::M2::Methodology::Methodology Library::Common Elements::Work Product Kinds
<b>Brief Description</b>	
<b>Description</b>	These are collections of delivered work products. They form the basis of exchange between organizations.

**Table 3.9: Delivered**

### 3.1.2 Tasks

#### 3.1.2.1 Add General Documentation

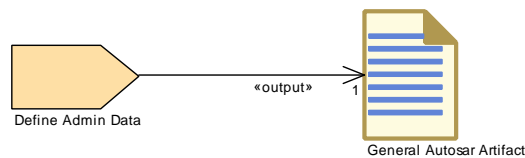


**Figure 3.1: Add General Documentation**

<b>Task Definition</b>	<b>Add General Documentation</b>		
<b>Package</b>	AUTOSAR Root::M2::Methodology::Methodology Library::Common Elements::Tasks		
<b>Brief Description</b>			
<b>Description</b>	Add General Documentation to work products (AR_MET_REQ069)		
<b>Relation Type</b>	<b>Related Element</b>	<b>Mul.</b>	<b>Note</b>
Produces	<a href="#">General Documentation</a>	1	

**Table 3.10: Add General Documentation**

#### 3.1.2.2 Define Admin Data

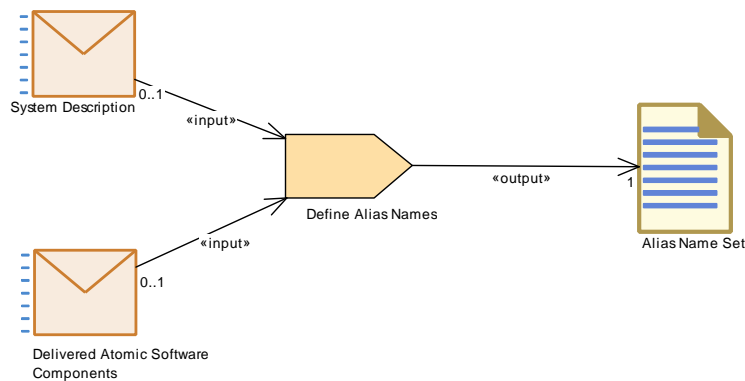


**Figure 3.2: Define Admin Data**

<b>Task Definition</b>	<b>Define Admin Data</b>		
<b>Package</b>	AUTOSAR Root::M2::Methodology::Methodology Library::Common Elements::Tasks		
<b>Brief Description</b>	Generic task to define admin data of an Identifiable within an AUTOSAR artifact.		
<b>Description</b>	<p>Generic task to define administration data (metamodel element AdminData) of an Identifiable within an AUTOSAR artifact. Note that administration data can be defined on several levels, namely for the top-level package of a General Autosar Artifact, but also for sub-packages and for other Identifiables within the XML description.</p> <p>Administration data include versioning information of the model element via the meta-class DocRevision, and the aggregation of user specific data via so-called special data groups, meta-class Sdg.</p> <p>For more details on the administration data content see AUTOSAR_TPS_GenericStructureTemplate.pdf.</p>		
<b>Relation Type</b>	<b>Related Element</b>	<b>Mul.</b>	<b>Note</b>
Produces	<a href="#">General Autosar Artifact</a>	1	

**Table 3.11: Define Admin Data**

### 3.1.2.3 Define Alias Names

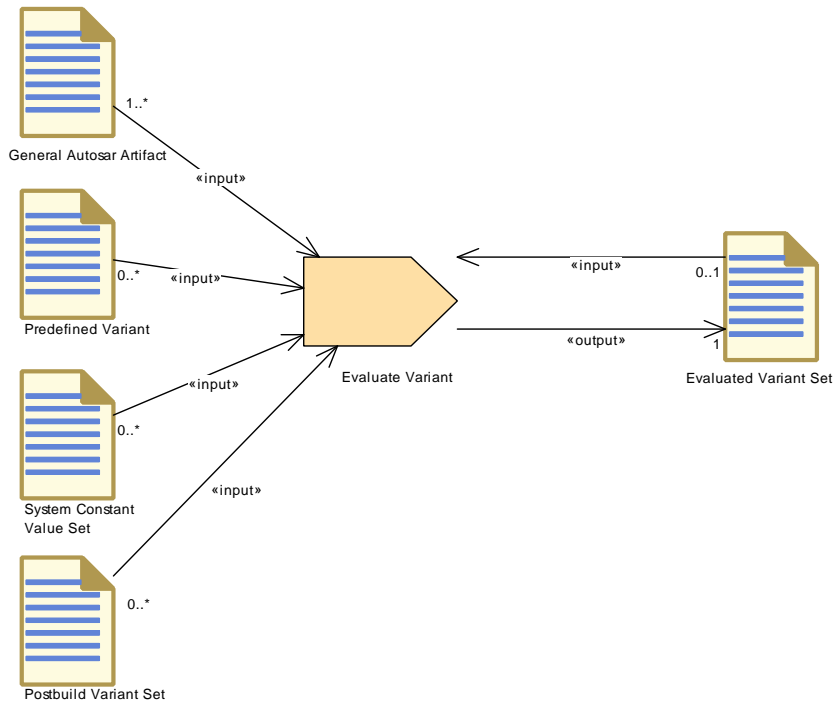


**Figure 3.3: Define Alias Names**

<b>Task Definition</b>	<b>Define Alias Names</b>		
<b>Package</b>	AUTOSAR Root::M2::Methodology::Methodology Library::Common Elements::Tasks		
<b>Brief Description</b>	Define a set of alias names for AUTOSAR model elements.		
<b>Description</b>	<p>The usual mechanism for defining global names for nested elements within an AUTOSAR XML model is the Flat Map. However in the cooperation with non-AUTOSAR tools, there are uses cases which require additional alias names which can be defined by this task.</p> <p>It can be applied on System and on ECU level as well. Possible use cases are for example:</p> <ul style="list-style-type: none"> <li>• The names defined by an ECU Flat Map, System Flat Map or Partial Flat Map shall be superseded when used by an external tool (e.g. in order to use a more general string format).</li> <li>• Resolve name conflicts for elements which cannot be referred in the context of a Flat Map (e.g. for elements directly defined in the scope of ARPackages, like System Constants to be displayed by A2L tools).</li> </ul>		
<b>Relation Type</b>	<b>Related Element</b>	<b>Mul.</b>	<b>Note</b>
Consumes	<a href="#">Delivered Atomic Software Components</a>	0..1	Needed for definition of alias names in the scope of delivered software components.
Consumes	<a href="#">System Description</a>	0..1	Needed for definition of alias names with system, system extract or ECU scope, depending of the role of the System Description.
Produces	<a href="#">Alias Name Set</a>	1	

**Table 3.12: Define Alias Names**

**3.1.2.4 Evaluate Variant**

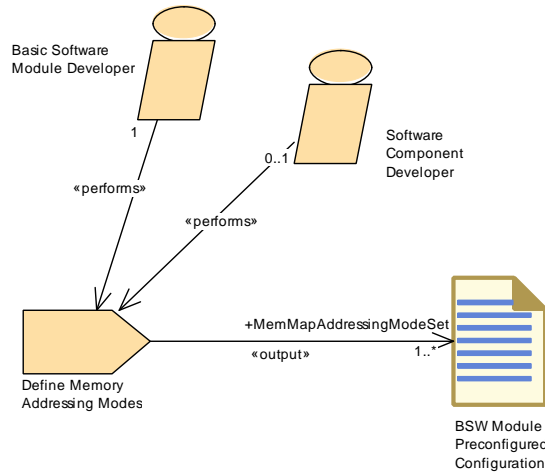


**Figure 3.4: Evaluate Variant**

<b>Task Definition</b>	<b>Evaluate Variant</b>		
<b>Package</b>	AUTOSAR Root::M2::Methodology::Methodology Library::Common Elements::Tasks		
<b>Brief Description</b>	Document the evaluation of variants in the software description.		
<b>Description</b>	<p>Create or modify an Evaluated Variant Set in order to document the outcome of an evaluation of particular variants. This namely means setting the "approval status" in relation to a given set of PredefinedVariants and a given set of model elements (e.g. a particular Software Component) which were evaluated.</p> <p>This is a general task which can be applied on different levels, therefore the input is modeled as General Autosar Artifact.</p>		
<b>Relation Type</b>	<b>Related Element</b>	<b>Mul.</b>	<b>Note</b>
Consumes	General Autosar Artifact	1..*	
Consumes	Evaluated Variant Set	0..1	
Consumes	Postbuild Variant Set	0..*	
Consumes	Predefined Variant	0..*	
Consumes	System Constant Value Set	0..*	
Produces	Evaluated Variant Set	1	

**Table 3.13: Evaluate Variant**

### 3.1.2.5 Define Memory Addressing Modes

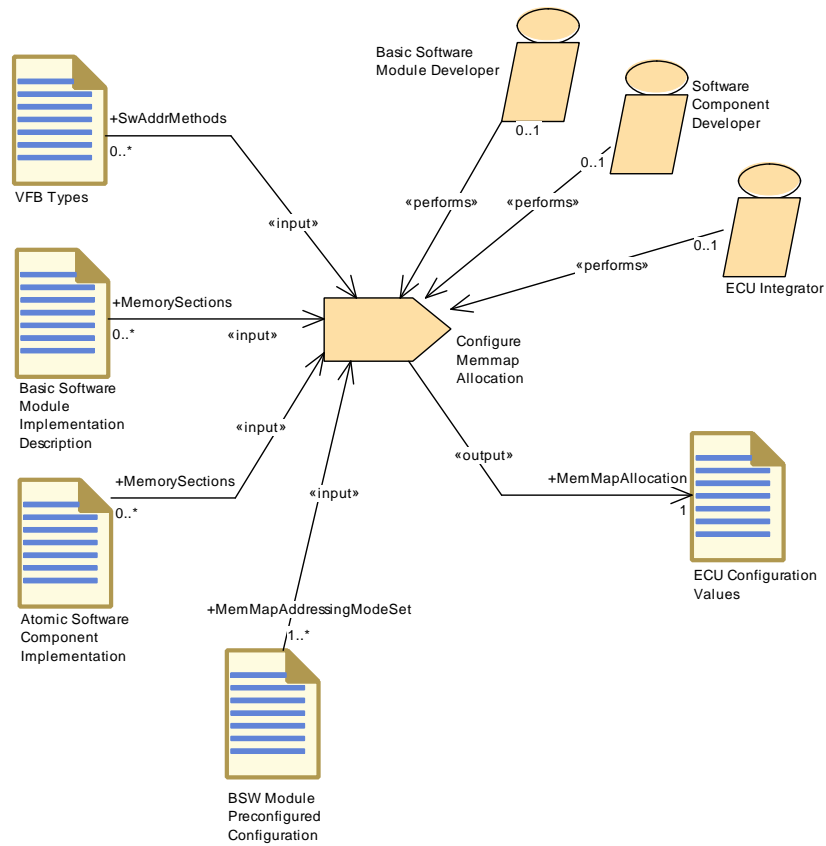


**Figure 3.5: Define Memory Addressing Modes**

<b>Task Definition</b>	<b>Define Memory Addressing Modes</b>		
<b>Package</b>	AUTOSAR Root::M2::Methodology::Methodology Library::Common Elements::Tasks		
<b>Brief Description</b>			
<b>Description</b>	<p>Define the compiler specific configuration used in a later task to generate the "pragmas" in memory mapping header files.</p> <p>The output (container MemMapAddressingModeSet) is treated as pre-configured configuration values for the "module" MemMap, because it can be prepared independently from the configuration for a specific integration project.</p> <p>Meth.bindingTime = SystemDesignTime</p>		
<b>Relation Type</b>	<b>Related Element</b>	<b>Mul.</b>	<b>Note</b>
Performed by	Basic Software Module Developer	1	
Performed by	Software Component Developer	0..1	
Produces	BSW Module Preconfigured Configuration	1..*	MemMapAddressingModeSet: Meth.bindingTime = SystemDesignTime

**Table 3.14: Define Memory Addressing Modes**

### 3.1.2.6 Configure Memmap Allocation

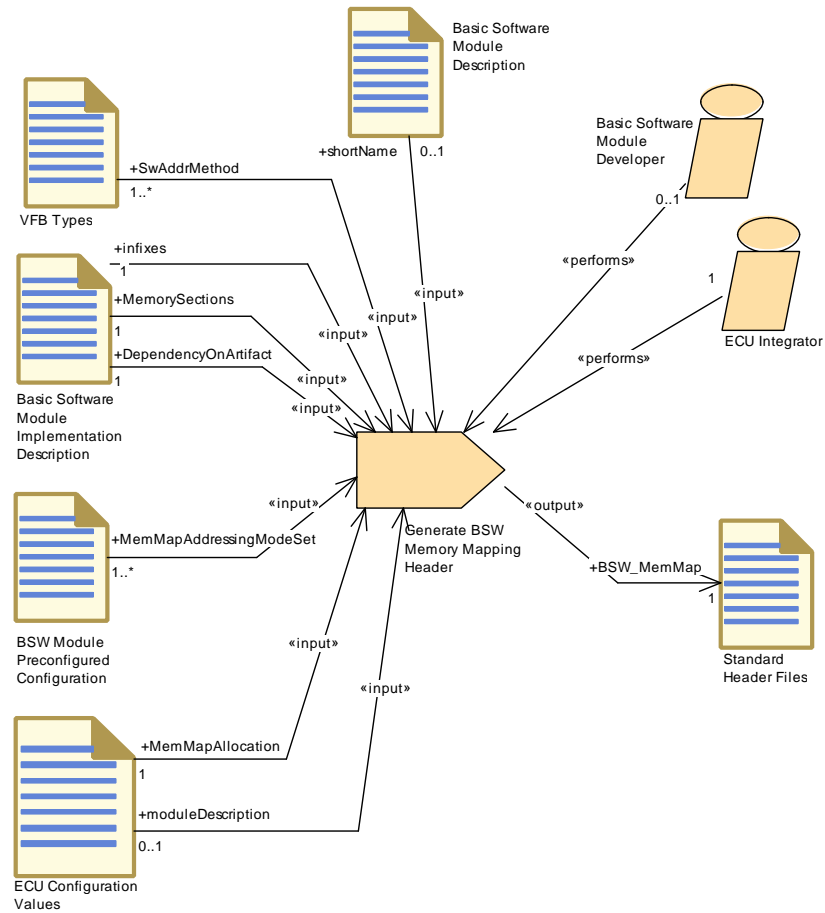


**Figure 3.6: Configure Memmap Allocation**

<b>Task Definition</b>	<b>Configure Memmap Allocation</b>		
<b>Package</b>	AUTOSAR Root::M2::Methodology::Methodology Library::Common Elements::Tasks		
<b>Brief Description</b>			
<b>Description</b>	<p>Configure the ECU Configuration part MemMapAllocation for module "MemMap".</p> <p>The output is to be used for generating memory mapping headers during ECU integration as well as for BSW and SWC compiling/linking in local environments.</p> <p>MemMapAllocation defines a mapping between abstract memory sections used in BSW or SWC code and compiler specific configuration elements. The abstract sections are identified via links to SwAddrmethods (generic mapping) resp. MemorySections of the XML input files. The compiler specific configuration is given as a pre-configured configuration for module "MemMap" via the container MemMapAddressingModeSet.</p> <p>For more information refer to document ID 128: SWS_MemoryMapping.</p> <p>Meth.bindingTime = SystemDesignTime</p>		
<b>Relation Type</b>	<b>Related Element</b>	<b>Mul.</b>	<b>Note</b>
Performed by	<a href="#">Basic Software Module Developer</a>	0..1	
Performed by	<a href="#">ECU Integrator</a>	0..1	
Performed by	<a href="#">Software Component Developer</a>	0..1	
Consumes	<a href="#">BSW Module Pre-configured Configuration</a>	1..*	MemMapAddressingModeSet: Collection of compiler specific configuration elements for memory allocation and addressing modes.
Consumes	<a href="#">Atomic Software Component Implementation</a>	0..*	MemorySections:
Consumes	<a href="#">Basic Software Module Implementation Description</a>	0..*	MemorySections:
Consumes	<a href="#">VFB Types</a>	0..*	SwAddrMethods: SwAddrMethods used for the generic mapping. Note that one SwAddrmethod can represent several memory sections.
Produces	<a href="#">ECU Configuration Values</a>	1	MemMapAllocation: Meth.bindingTime = SystemDesignTime

**Table 3.15: Configure Memmap Allocation**

### 3.1.2.7 Generate BSW Memory Mapping Header



**Figure 3.7: Generate BSW Memory Mapping Header**

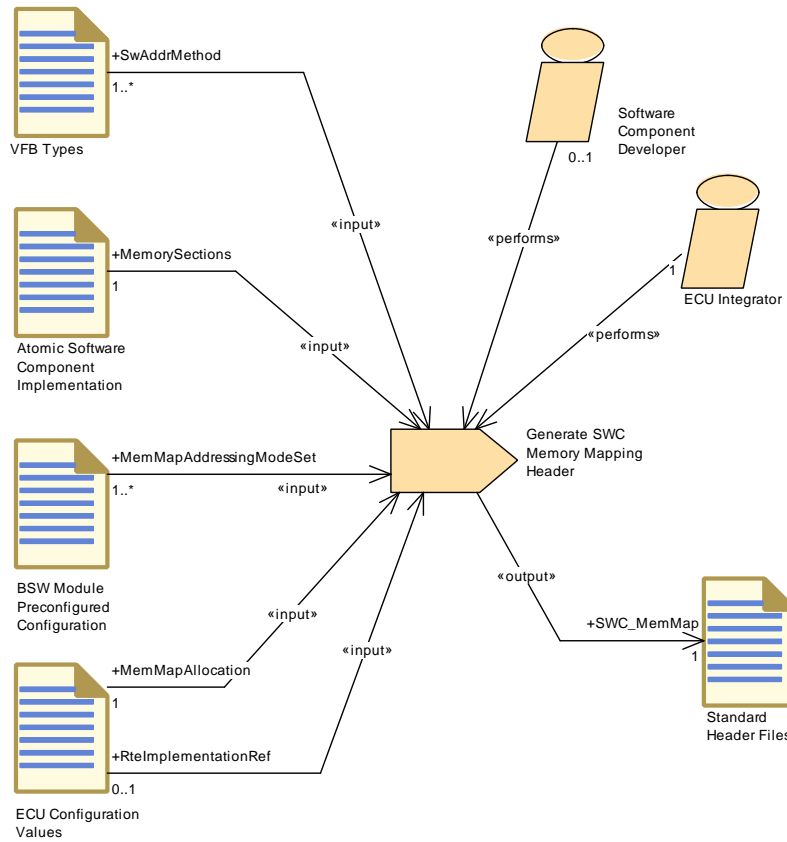


<b>Task Definition</b>	<b>Generate BSW Memory Mapping Header</b>		
<b>Package</b>	AUTOSAR Root::M2::Methodology::Methodology Library::Common Elements::Tasks		
<b>Brief Description</b>			
<b>Description</b>	<p>Generate a memory mapping header to be used for one BSW module (the default case) or a group of BSW modules (e.g. an ICC2 cluster). Note that the usage of one MemMap.h for the complete BSW of one build environment is possible, but deprecated.</p> <p>This task can be used in ECU scope or with preliminary scope to test BSW modules. Note that the content of the generated file is compiler specific (#pragma statements).</p> <p>Inputs are:</p> <ul style="list-style-type: none"> <li>• From Basic Software Module Description: The shortName is used (in the default case) as the first part of the generated file name.</li> <li>• From VFB Types: Properties of abstract sections given by SwAddrmethods, which in turn are referred by MemorySection as well as by MemMapAllocation.</li> <li>• From Basic Software Module Implementation Description: Names of the individual abstract sections (preprocessor macros) used in the code (including optional prefixes overriding the default rule); optional infixes for the file name (if the default rule is used); optional declaration of file name (element DependencyOnArtifact) overriding the default rule.</li> <li>• From Preconfigured Configuration for module "MemMap": Collection of compiler specific configuration elements.</li> <li>• From ECU Configuration for module "MemMap" : MemMapAllocation - this is the concrete mapping for this environment.</li> <li>• From ECU Configuration: Find the list of used BSW modules in case the task is done for the whole BSW (EcucValueCollection.ecucValue.moduleDescription).</li> </ul> <p>Meth.bindingTime = CodeGenerationTime</p>		
<b>Relation Type</b>	<b>Related Element</b>	<b>Mul.</b>	<b>Note</b>
Performed by	<a href="#">ECU Integrator</a>	1	
Performed by	<a href="#">Basic Software Module Developer</a>	0..1	
Consumes	<a href="#">Basic Software Module Implementation Description</a>	1	infixes: Optional infixes (denoting instance and vendor ID) to be used within the created header file name. Meth.bindingTime = SystemDesignTime
Consumes	<a href="#">Basic Software Module Implementation Description</a>	1	DependencyOnArtifact: Can be used to override the default name of the memory mapping header file. Meth.bindingTime = SystemDesignTime

<b>Relation Type</b>	<b>Related Element</b>	<b>Mul.</b>	<b>Note</b>
Consumes	<a href="#">Basic Software Module Implementation Description</a>	1	MemorySections: MemorySections defined for a BSW module. This input includes optional prefixes for memory sections overriding the default rule. Meth.bindingTime = SystemDesignTime
Consumes	<a href="#">ECU Configuration Values</a>	1	MemMapAllocation: Mapping of the abstract sections (SwAddressMethods for generic mapping resp. MemorySection Elements for specific mapping) to the compiler specific MemMapAddressingModes. Meth.bindingTime = SystemDesignTime
Consumes	<a href="#">BSW Module Pre-configured Configuration</a>	1..*	MemMapAddressingModeSet: Collection of compiler specific configuration elements for memory allocation. Meth.bindingTime = SystemDesignTime
Consumes	<a href="#">VFB Types</a>	1..*	SwAddrMethod: Referred SwAddrMethods Meth.bindingTime = SystemDesignTime
Consumes	<a href="#">Basic Software Module Description</a>	0..1	shortName: The BSW module's shortName is used as the first part of the generated file name, in case the default rule applies. Meth.bindingTime = SystemDesignTime
Consumes	<a href="#">ECU Configuration Values</a>	0..1	moduleDescription: List of used BSW modules (EcucValueCollection.ecucValue.moduleDescription) Meth.bindingTime = SystemDesignTime
Produces	<a href="#">Standard Header Files</a>	1	BSW_MemMap: The memory mapping header file to be used for one or more BSW modules in a given build environment.  The file name has in the standardized case a form like {Mip}_MemMap.h in which the prefixes {Mip} are determined by the module (or cluster) name and optional infixes.  However, it is also possible to create a completely different filename via explicit declaration in the BSW Module Implementation.  For more detailed rules on the name of the generated file refer to AUTOSAR_SWS_MemoryMapping. Meth.bindingTime = CodeGenerationTime

**Table 3.16: Generate BSW Memory Mapping Header**

### 3.1.2.8 Generate SWC Memory Mapping Header



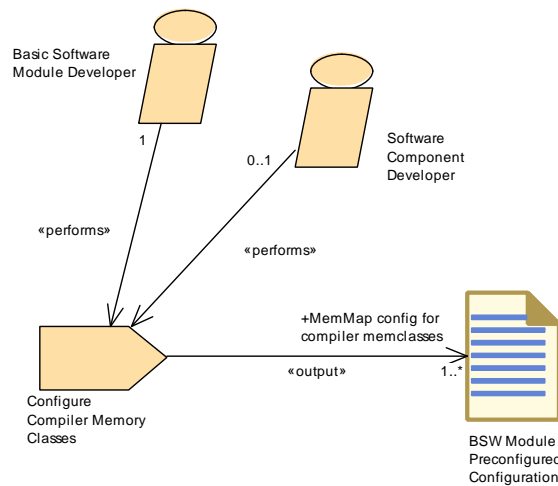
**Figure 3.8: Generate SWC Memory Mapping Header**

<b>Task Definition</b>	<b>Generate SWC Memory Mapping Header</b>		
<b>Package</b>	AUTOSAR Root::M2::Methodology::Methodology Library::Common Elements::Tasks		
<b>Brief Description</b>			
<b>Description</b>	<p>Generate the memory mapping header file for one build environment and one Atomic Software Component. This task can be used in ECU scope or with preliminary scope to test software component. Note that the generated header file is compiler specific (#pragma statements).</p> <p>Inputs are:</p> <ul style="list-style-type: none"> <li>• From VFB Types: Properties of abstract sections given by SwAddrmethods, which in turn are referred by MemorySection as well as by MemMapAllocation</li> <li>• From Software Component Implementation, element MemorySection: Names of the individual abstract sections (preprocessor macros) used in the code.</li> <li>• From Preconfigured Configuration for module "MemMap": Collection of compiler specific configuration elements.</li> <li>• From ECU Configuration for module "MemMap" : MemMapAllocation - This is the concrete mapping for this environment.</li> <li>• From ECU Configuration: Find (optionally) the list of used software component implementations by usage of the RTE ECU Configuration "RteSwComponentType.RteImplementationRef"</li> </ul> <p>Meth.bindingTime = CodeGenerationTime</p>		
<b>Relation Type</b>	<b>Related Element</b>	<b>Mul.</b>	<b>Note</b>
Performed by	<a href="#">ECU Integrator</a>	1	
Performed by	<a href="#">Software Component Developer</a>	0..1	
Consumes	<a href="#">Atomic Software Component Implementation</a>	1	MemorySections: MemorySections defined for an Atomic Software Component. Meth.bindingTime = SystemDesignTime
Consumes	<a href="#">ECU Configuration Values</a>	1	MemMapAllocation: Mapping of the abstract sections (SwAddressMethods for generic mapping resp. MemorySection Elements for specific mapping) to the compiler specific MemMapAddressingModes. Meth.bindingTime = SystemDesignTime
Consumes	<a href="#">BSW Module Pre-configured Configuration</a>	1..*	MemMapAddressingModeSet: Collection of compiler specific configuration elements for memory allocation. Meth.bindingTime = SystemDesignTime
Consumes	<a href="#">VFB Types</a>	1..*	SwAddrMethod: Referred SwAddrMethods Meth.bindingTime = SystemDesignTime

Relation Type	Related Element	Mul.	Note
Consumes	ECU Configuration Values	0..1	RteImplementationRef: Existence of SWCs could be identified by usage of the RTE ECU Configuration "RteSwComponentType.RteImplementationRef" Meth.bindingTime = SystemDesignTime
Produces	Standard Header Files	1	SWC_MemMap: One header per software component type for a given build environment.  The file name follows the pattern {componentTypeName}_MemMap.h in which the prefix componentTypeName is determined by the software component type name.  For more detailed rules on the name of the generated file refer to AUTOSAR_SWS_MemoryMapping. Meth.bindingTime = CodeGenerationTime

**Table 3.17: Generate SWC Memory Mapping Header**

### 3.1.2.9 Configure Compiler Memory Classes

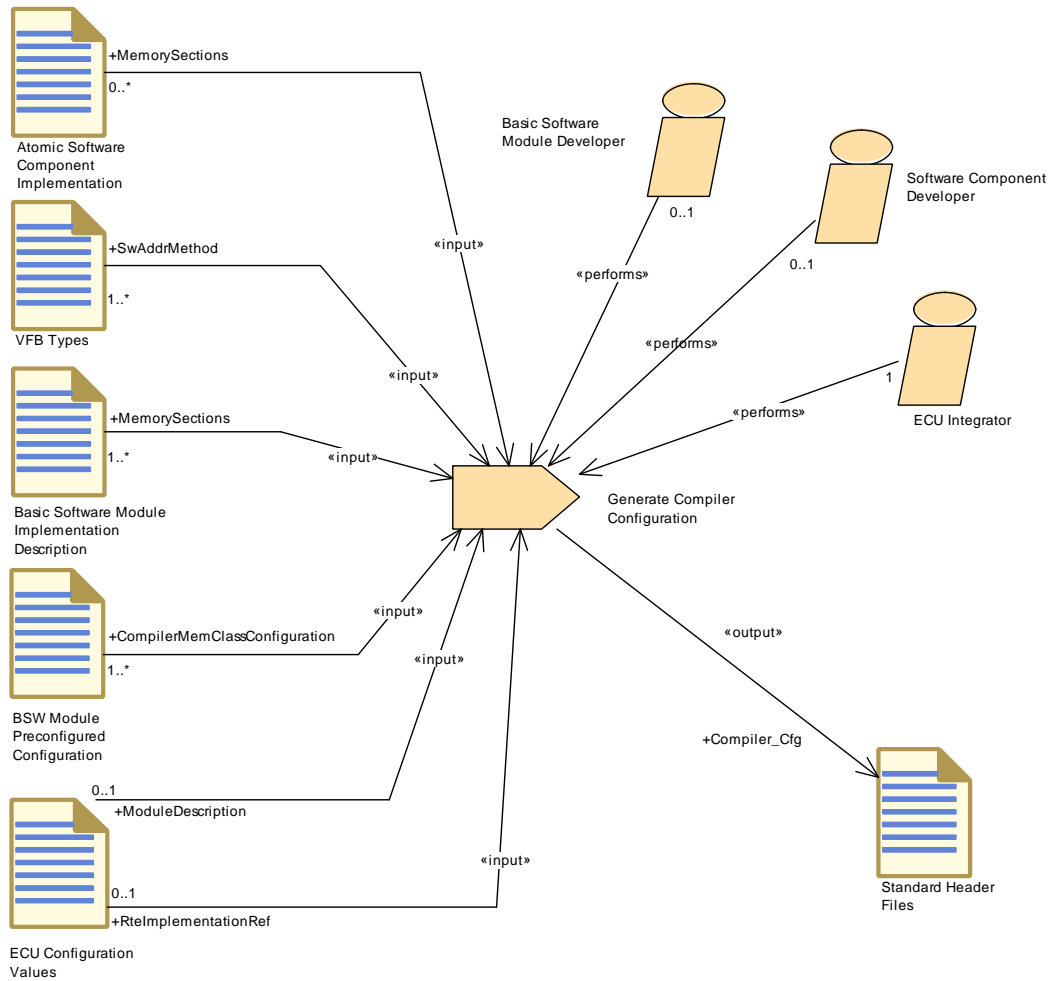


**Figure 3.9: Define Compiler Memory Classes**

<b>Task Definition</b>	<b>Configure Compiler Memory Classes</b>		
<b>Package</b>	AUTOSAR Root::M2::Methodology::Methodology Library::Common Elements::Tasks		
<b>Brief Description</b>			
<b>Description</b>	<p>Define the compiler specific configuration for "memory classes" used in a later task to generate the preprocessor code of the compiler configuration header file (Compiler_Cfg.h).</p> <p>The output is treated as pre-configured configuration values for the "module" MemMap, because it can be prepared independently from the configuration for a specific integration project.</p> <p>Meth.bindingTime = SystemDesignTime</p>		
<b>Relation Type</b>	<b>Related Element</b>	<b>Mul.</b>	<b>Note</b>
Performed by	<a href="#">Basic Software Module Developer</a>	1	
Performed by	<a href="#">Software Component Developer</a>	0..1	
Produces	<a href="#">BSW Module Pre-configured Configuration</a>	1..*	<p>MemMap config for compiler memclasses: Set the parameter values that define generic MemClassSymbols (i.e. those not defined by modules or SWCs.).</p> <p>Set the parameter values that define the implementation behind all kind of MemClassSymbols (generic and local ones).</p> <p>Meth.bindingTime = SystemDesignTime</p>

**Table 3.18: Configure Compiler Memory Classes**

### 3.1.2.10 Generate Compiler Configuration



**Figure 3.10: Generate Compiler Configuration**

<b>Task Definition</b>	<b>Generate Compiler Configuration</b>		
<b>Package</b>	AUTOSAR Root::M2::Methodology::Methodology Library::Common Elements::Tasks		
<b>Brief Description</b>			
<b>Description</b>	<p>This task generates a compiler configuration header (Compiler_cfg.h) for one build environment to be used for all BSW modules and software components.</p> <p>Meth.bindingTime = CodeGenerationTime</p>		
<b>Relation Type</b>	<b>Related Element</b>	<b>Mul.</b>	<b>Note</b>
Performed by	<a href="#">ECU Integrator</a>	1	
Performed by	<a href="#">Basic Software Module Developer</a>	0..1	
Performed by	<a href="#">Software Component Developer</a>	0..1	

<b>Relation Type</b>	<b>Related Element</b>	<b>Mul.</b>	<b>Note</b>
Consumes	<a href="#">BSW Module Pre-configured Configuration</a>	1..*	CompilerMemClassConfiguration: The parameters "MemMapCompilerMemClassSymbolImpl" and "MemMapGenericCompilerMemClassSymbolImpl" define the implementation behind a MemClassSymbol. Meth.bindingTime = SystemDesignTime
Consumes	<a href="#">Basic Software Module Implementation Description</a>	1..*	MemorySections: Find referred SwAddrMethods or specific memClassSymbols in the MemorySections defined for BSW modules. Meth.bindingTime = SystemDesignTime
Consumes	<a href="#">VFB Types</a>	1..*	SwAddrMethod: Referred SwAddrMethods. They provide the default names for the compiler memory classes. Meth.bindingTime = SystemDesignTime
Consumes	<a href="#">ECU Configuration Values</a>	0..1	RteImplementationRef: Existence of SWCs could be identified by usage of the RTE ECU Configuration "RteSwComponentType.RteImplementationRef" Meth.bindingTime = SystemDesignTime
Consumes	<a href="#">ECU Configuration Values</a>	0..1	ModuleDescription: List of used BSW modules (EcucValueCollection.ecucValue.moduleDescription) Meth.bindingTime = SystemDesignTime
Consumes	<a href="#">Atomic Software Component Implementation</a>	0..*	MemorySections: Find referred SwAddrMethods or specific memClassSymbols in the MemorySections defined for Atomic Software Components. Meth.bindingTime = SystemDesignTime
Produces	<a href="#">Standard Header Files</a>	1	Compiler_Cfg: The output file "Compiler_Cfg.h" configures the abstraction of compiler specifics. Meth.bindingTime = CodeGenerationTime

**Table 3.19: Generate Compiler Configuration**

### 3.1.3 Work Products

#### 3.1.3.1 General Documentation



<b>Artifact</b>	<b>General Documentation</b>		
<b>Package</b>	AUTOSAR Root::M2::Methodology::Methodology Library::Common Elements::Work Products		
<b>Brief Description</b>			
<b>Description</b>	General documentation link to a given work product		
<b>Kind</b>	Custom		
<b>Relation Type</b>	<b>Related Element</b>	<b>Mul.</b>	<b>Note</b>
Aggregated by	<a href="#">General Deliverable</a>	0..*	
Produced by	<a href="#">Add General Documentation</a>	1	

**Table 3.20: General Documentation**

### 3.1.3.2 Alias Name Set

<b>Artifact</b>	<b>Alias Name Set</b>		
<b>Package</b>	AUTOSAR Root::M2::Methodology::Methodology Library::Common Elements::Work Products		
<b>Brief Description</b>	Set of alias names for AUTOSAR model elements for usage outside of AUTOSAR.		
<b>Description</b>	<p>Set of alias names, each consisting of the name (string) itself and the reference to the model element it renames.</p> <p>Each reference to a model element is either a reference to an Identifiable or to an entry in an ECU Flat Map or System Flat Map.</p> <p>For an explanation of uses cases see task Define Alias Names.</p>		
<b>Kind</b>	AUTOSAR XML		
<b>Relation Type</b>	<b>Related Element</b>	<b>Mul.</b>	<b>Note</b>
Aggregated by	<a href="#">Delivered Atomic Software Components</a>	0..1	Alias names valid in the context of the delivered components.
Aggregated by	<a href="#">System Description</a>	0..*	
Produced by	<a href="#">Define Alias Names</a>	1	
Consumed by	<a href="#">Add Documentation to the Software Component</a>	0..*	Optional input in order to refer to unique names defined in an Alias Name Set (e.g. System Constants).
Consumed by	<a href="#">Generate A2L</a>	0..*	
Use meta model element	AliasNameSet	1	

**Table 3.21: Alias Name Set**

### 3.1.3.3 Evaluated Variant Set

<b>Artifact</b>	<b>Evaluated Variant Set</b>		
<b>Package</b>	AUTOSAR Root::M2::Methodology::Methodology Library::Common Elements::Work Products		
<b>Brief Description</b>	A set of evaluated variants		
<b>Description</b>	<p>This artifact represents a table defining which ArElements or ArPackages (referred as "evaluatedElements") are able to support one or more particular variant. It can thus be used to document which variants are support by a certain delivery, e.g. of a software component or of a system.</p> <p>In other words, for a given set of evaluatedElements this element represents a table of evaluated variants, where each PredefinedVariant represents one column. In this column each descendant swSystemConstantValue (part of System Constant Value Set) resp. postbuildVariantCriterionValue (part of Postbuid Variant Set) represents one entry.</p> <p>In a graphical representation each swSystemConstantValueSet / postBuildVariantCriterionValueSet could be used as an intermediate headline in the table column.</p> <p>The Evaluated Variant Set comes with an attribute "approvalStatus". If this is set to "APPROVED" it expresses that the evaluatedElements are known be valid for the given evaluated variants.</p> <p>Note that an evaluatedElement could be another Evaluated Variant Set. This allows to establish a hierarchy of EvaluatedVariantSets.</p>		
<b>Kind</b>	AUTOSAR XML		
<b>Relation Type</b>	<b>Related Element</b>	<b>Mul.</b>	<b>Note</b>
Aggregated by	<a href="#">Delivered Atomic Software Components</a>	0..1	
Aggregated by	<a href="#">ECU Extract of System Variant Model</a>	0..*	
Aggregated by	<a href="#">System Description</a>	0..*	
Aggregated by	<a href="#">VFB System</a>	0..*	
Produced by	<a href="#">Define System Variants</a>	1	
Produced by	<a href="#">Evaluate Variant</a>	1	
Produced by	<a href="#">Define Integration Variant</a>	0..1	Meth.bindingTime = SystemDesignTime
Produced by	<a href="#">Define VFB Variants</a>	0..*	
Consumed by	<a href="#">Evaluate Variant</a>	0..1	
Consumed by	<a href="#">Extract ECU System Variant Model</a>	0..*	
Use meta model element	EvaluatedVariant Set	1	

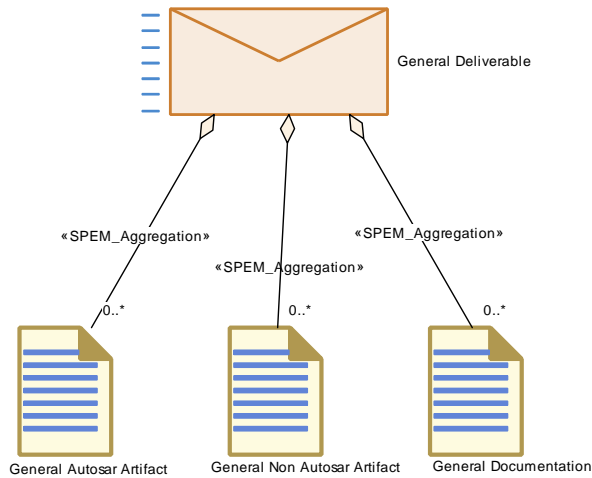
**Table 3.22: Evaluated Variant Set**

### 3.1.3.4 General Autosar Artifact

<b>Artifact</b>	<b>General Autosar Artifact</b>		
<b>Package</b>	AUTOSAR Root::M2::Methodology::Methodology Library::Common Elements::Work Products		
<b>Brief Description</b>	Describes the meta data for an AUTOSAR artifact.		
<b>Description</b>	<p>This artifact represents the data which are common to all AUTOSAR XML artifacts.</p> <p>Each file starts with the root element AUTOSAR.</p> <p>The content of such an artifact below this root element is organized by packages using the element ARPackage. Packages can be nested. It is important to understand, that the hierarchy defined via packages and other aggregated elements can (in general) span over several XML files, i.e. over several artifacts. That means, if an aggregation is "split" between several files, each file is considered as a separate artifact by the methodology, even if the elements are formally aggregated within the same package.</p> <p>All elements derived from meta-class Identifiable can carry documentation and administrative description based on the element AdminData. Note that ARPackage is itself derived from Identifiable, so there can be AdminData for the top-level package, for sub-packages and for more specific elements (derived from Identifiable) as well. The AdminData among other things contain revision information (including the artifact version) based on the metamodel element DocRevision .</p>		
<b>Kind</b>	AUTOSAR XML		
<b>Relation Type</b>	<b>Related Element</b>	<b>Mul.</b>	<b>Note</b>
Aggregated by	<a href="#">General Deliverable</a>	0..*	
Produced by	<a href="#">Define Admin Data</a>	1	
Consumed by	<a href="#">Evaluate Variant</a>	1..*	
Use meta model element	ARPackage	1	
Use meta model element	AUTOSAR	1	

**Table 3.23: General Autosar Artifact**

**3.1.3.5 General Deliverable**



**Figure 3.11: General Deliverable**

<b>Deliverable</b>	<b>General Deliverable</b>		
<b>Package</b>	AUTOSAR Root::M2::Methodology::Methodology Library::Common Elements::Work Products		
<b>Brief Description</b>	General data for an XML based deliverable within AUTOSAR.		
<b>Description</b>	<p>General data for an XML based deliverable within AUTOSAR : Especially it contains a catalog of all included artifacts. These can be AUTOSAR artifacts (see General Autosar Artifact) or non-AUTOSAR artifacts (see General Non AUTOSAR Artifact).</p> <p>An AUTOSAR XML artifact which is contained in the catalog may refer to a non AUTOSAR Artifact within the catalog via the metamodel element AutosarEngineeringObject (see AUTOSAR_TPS_GenericStructureTemplate.pdf for further description).</p>		
<b>Kind</b>	Delivered		
<b>Relation Type</b>	<b>Related Element</b>	<b>Mul.</b>	<b>Note</b>
Aggregates	General Autosar Artifact	0..*	
Aggregates	General Documentation	0..*	
Aggregates	General Non Autosar Artifact	0..*	

**Table 3.24: General Deliverable**

**3.1.3.6 General Non-Autosar Artifact**

<b>Artifact</b>	<b>General Non Autosar Artifact</b>		
<b>Package</b>	AUTOSAR Root::M2::Methodology::Methodology Library::Common Elements::Work Products		
<b>Brief Description</b>	Describes the data for a non AUTOSAR artifact.		
<b>Description</b>	Describes the data for a non AUTOSAR artifact.		
<b>Kind</b>	Custom		
<b>Relation Type</b>	<b>Related Element</b>	<b>Mul.</b>	<b>Note</b>
Aggregated by	<a href="#">General Deliverable</a>	0..*	
Consumed by	<a href="#">Provide RTE Calibration Dataset</a>	1..*	input from calibration process

**Table 3.25: General Non Autosar Artifact**

### 3.1.3.7 Postbuild Variant Set

<b>Artifact</b>	<b>Postbuild Variant Set</b>		
<b>Package</b>	AUTOSAR Root::M2::Methodology::Methodology Library::Common Elements::Work Products		
<b>Brief Description</b>	Set of Postbuild Variant Criterion Values used to define post-build variants of the software.		
<b>Description</b>	<p>Set of Postbuild Variant Criterion Values used to define post-build variants of the software.</p> <p>Such a set does not necessarily define a variant which is actually used. To define a meaningful variant in the production process, such a set is to be used via reference by artifact PredefinedVariant.</p>		
<b>Kind</b>	AUTOSAR XML		
<b>Relation Type</b>	<b>Related Element</b>	<b>Mul.</b>	<b>Note</b>
Aggregated by	<a href="#">Delivered Atomic Software Components</a>	0..1	
Aggregated by	<a href="#">ECU Extract of System Variant Model</a>	0..*	
Aggregated by	<a href="#">System Description</a>	0..*	
Aggregated by	<a href="#">VFB System</a>	0..*	
In/out	<a href="#">Define System Variants</a>	1	
In/out	<a href="#">Define Integration Variant</a>	0..*	
In/out	<a href="#">Define VFB Variants</a>	0..*	
Consumed by	<a href="#">Generate RTE Postbuild Dataset</a>	1	
Consumed by	<a href="#">Generate Atomic Software Component Contract Header Files</a>	0..1	

<i>Relation Type</i>	<i>Related Element</i>	<i>Mul.</i>	<i>Note</i>
Consumed by	<a href="#">Generate RTE Prebuild Dataset</a>	0..1	
Consumed by	<a href="#">Evaluate Variant</a>	0..*	
Consumed by	<a href="#">Extract ECU System Variant Model</a>	0..*	
Use meta model element	PostBuildVariant CriterionValueSet	1	

**Table 3.26: Postbuild Variant Set**

### 3.1.3.8 Predefined Variant

<i>Artifact</i>	<i>Predefined Variant</i>		
<b>Package</b>	AUTOSAR Root::M2::Methodology::Methodology Library::Common Elements::Work Products		
<b>Brief Description</b>	Defines a variant predefined for usage in subsequent process steps.		
<b>Description</b>	Defines one variant of a software description for delivery and/or usage in subsequent process steps. The actual definition of all settings which make up this variant is given by attached System Constant Value Set (all settings which are resolved prior to post-build) and/or Postbuild Variant Set (all settings which are resolved after software build). These sets may be part of the same artifact or may be separated artifacts. Via these settings, the actual values which make up a particular variant, are selected.		
<b>Kind</b>	AUTOSAR XML		
<i>Relation Type</i>	<i>Related Element</i>	<i>Mul.</i>	<i>Note</i>
Aggregated by	<a href="#">Delivered Atomic Software Components</a>	0..*	
Aggregated by	<a href="#">ECU Extract of System Variant Model</a>	0..*	
Aggregated by	<a href="#">System Description</a>	0..*	
Aggregated by	<a href="#">VFB System</a>	0..*	
Produced by	<a href="#">Define Integration Variant</a>	1	Meth.bindingTime = SystemDesignTime
Produced by	<a href="#">Define System Variants</a>	1	
Produced by	<a href="#">Define VFB Variants</a>	0..*	
Consumed by	<a href="#">Generate BSW Module Prebuild Data Set</a>	1	
Consumed by	<a href="#">Generate RTE Postbuild Dataset</a>	1	
Consumed by	<a href="#">Generate RTE Prebuild Dataset</a>	1	

<i>Relation Type</i>	<i>Related Element</i>	<i>Mul.</i>	<i>Note</i>
Consumed by	Generate Atomic Software Component Contract Header Files	0..1	
Consumed by	Evaluate Variant	0..*	
Consumed by	Extract ECU System Variant Model	0..*	
Consumed by	Generate Component Prebuild Data Set	0..*	
Use meta model element	PredefinedVariant	1	

**Table 3.27: Predefined Variant**

### 3.1.3.9 Standard Header Files

<i>Artifact</i>	<b>Standard Header Files</b>		
<i>Package</i>	AUTOSAR Root::M2::Methodology::Methodology Library::Common Elements::Work Products		
<i>Brief Description</i>	Overall header files to be included by each standardized BSW module, optionally also by Software Component code.		
<i>Description</i>	<p>Overall header files to be included by each standardized BSW module, optionally also by Software Component code. For simplicity of the methodology, these are modeled as one artifact though in practice these are several different files:</p> <ul style="list-style-type: none"> <li>• (&lt;prefixes&gt;_)MemMap.h - defines a common set of macros in order to define abstract memory sections for code and data in the source code . The prefixes indicates whether the scope is limited to a component, module or some other source code area (e.g. an ICC2 cluster). Note that the usage of one MemMap.h for the complete BSW is possible, but deprecated. It is also possible to use a completely different filename via explicit declaration in the BSW Module Implementation Description.</li> <li>• Std_Types.h - defines a common set of C data types for usage within the basic software, this header includes the following two headers:</li> <li>• Compiler.h (in turn including Compiler_Cfg.h) - for abstraction of compiler specifics, in which the second header is the part that is subject to configuration</li> <li>• Platform_Types.h - for abstraction of platform specific types</li> </ul>		
<i>Kind</i>	Source Code		
<i>Relation Type</i>	<i>Related Element</i>	<i>Mul.</i>	<i>Note</i>

<b>Relation Type</b>	<b>Related Element</b>	<b>Mul.</b>	<b>Note</b>
Produced by	Generate BSW Memory Mapping Header	1	<p>BSW_MemMap: The memory mapping header file to be used for one or more BSW modules in a given build environment.</p> <p>The file name has in the standardized case a form like {Mip}_MemMap.h in which the prefixes {Mip} are determined by the module (or cluster) name and optional infixes.</p> <p>However, it is also possible to create a completely different filename via explicit declaration in the BSW Module Implementation.</p> <p>For more detailed rules on the name of the generated file refer to AUTOSAR_SWS_MemoryMapping. Meth.bindingTime = CodeGenerationTime</p>
Produced by	Generate Compiler Configuration	1	<p>Compiler_Cfg: The output file "Compiler_Cfg.h" configures the abstraction of compiler specifics. Meth.bindingTime = CodeGenerationTime</p>
Produced by	Generate SWC Memory Mapping Header	1	<p>SWC_MemMap: One header per software component type for a given build environment.</p> <p>The file name follows the pattern {componentTypeName}_MemMap.h in which the prefix componentTypeName is determined by the software component type name.</p> <p>For more detailed rules on the name of the generated file refer to AUTOSAR_SWS_MemoryMapping. Meth.bindingTime = CodeGenerationTime</p>
Consumed by	Compile Atomic Software Component	1	Meth.bindingTime = CodeGenerationTime
Consumed by	Compile BSW Core Code	1	Meth.bindingTime = CodeGenerationTime
Consumed by	Compile ECU Source Code	1	Meth.bindingTime = CodeGenerationTime
Consumed by	Implement a BSW Module	1	Meth.bindingTime = CodeGenerationTime
Consumed by	Re-compile Component in ECU context	1	Meth.bindingTime = CodeGenerationTime



<i>Relation Type</i>	<i>Related Element</i>	<i>Mul.</i>	<i>Note</i>
Consumed by	Implement Atomic Software Component	0..1	Meth.bindingTime = CodeGenerationTime

**Table 3.28: Standard Header Files**

### 3.1.3.10 System Constant Value Set

<i>Artifact</i>	<b>System Constant Value Set</b>		
<i>Package</i>	AUTOSAR Root::M2::Methodology::Methodology Library::Common Elements::Work Products		
<i>Brief Description</i>	Set of System Constant Values used to handle variants.		
<i>Description</i>	<p>Set of System Constant Values used to define pre-build variants of the software.</p> <p>Such a set does not necessarily define a variant which is actually used. To define a meaningful variant in the production process, such a set is to be used via reference by artifact PredefinedVariant.</p>		
<i>Kind</i>	AUTOSAR XML		
<i>Relation Type</i>	<i>Related Element</i>	<i>Mul.</i>	<i>Note</i>
Aggregated by	Delivered Atomic Software Components	0..*	
Aggregated by	ECU Extract of System Variant Model	0..*	
Aggregated by	System Description	0..*	
Aggregated by	VFB System	0..*	
In/out	Define System Variants	1	
In/out	Define Integration Variant	0..*	
In/out	Define VFB Variants	0..*	
Consumed by	Generate BSW Module Prebuild Data Set	1	
Consumed by	Generate RTE Prebuild Dataset	1	
Consumed by	Generate Component Prebuild Data Set	1..*	Meth.bindingTime = CodeGenerationTime
Consumed by	Generate Atomic Software Component Contract Header Files	0..1	Meth.bindingTime = SystemDesignTime
Consumed by	Evaluate Variant	0..*	
Consumed by	Extract ECU System Variant Model	0..*	

<i>Relation Type</i>	<i>Related Element</i>	<i>Mul.</i>	<i>Note</i>
Use meta model element	SwSystemconstantValueSet	1	

**Table 3.29: System Constant Value Set**

### 3.1.4 Roles

<b>Role</b>	<b>AUTOSAR Partnership</b>		
<b>Package</b>	AUTOSAR Root::M2::Methodology::Methodology Library::Common Elements::Roles		
<b>Brief Description</b>	The AUTOSAR Partnership development defines standard artifacts.		
<b>Description</b>			
<b>Relation Type</b>	<b>Related Element</b>	<b>Mul.</b>	<b>Note</b>

**Table 3.30: AUTOSAR Partnership**

<b>Role</b>	<b>Basic Software Designer</b>		
<b>Package</b>	AUTOSAR Root::M2::Methodology::Methodology Library::Common Elements::Roles		
<b>Brief Description</b>	Role responsible for the overall design of the Basic Software.		
<b>Description</b>	Role responsible for the overall design of the Basic Software. In contrast to the Basic Software Module Developer he is responsible for the consistency of interfaces and data types between modules.		
<b>Relation Type</b>	<b>Related Element</b>	<b>Mul.</b>	<b>Note</b>
Performs	Define BSW Behavior	1	
Performs	Define BSW Entries	1	
Performs	Define BSW Interfaces	1	
Performs	Define BSW Types	1	
Performs	Generate E2E Protection Wrapper	1	
Performs	Define Vendor Specific Module Definition	0..1	

**Table 3.31: Basic Software Designer**

<b>Role</b>	<b>Basic Software Module Developer</b>		
<b>Package</b>	AUTOSAR Root::M2::Methodology::Methodology Library::Common Elements::Roles		
<b>Brief Description</b>	Role responsible to develop and deliver a Basic Software Module.		
<b>Description</b>			
<b>Relation Type</b>	<b>Related Element</b>	<b>Mul.</b>	<b>Note</b>

<b>Relation Type</b>	<b>Related Element</b>	<b>Mul.</b>	<b>Note</b>
Performs	Compile BSW Core Code	1	
Performs	Configure Compiler Memory Classes	1	
Performs	Create Library	1	
Performs	Define BSW Entries	1	
Performs	Define BSW Interfaces	1	
Performs	Define BSW Module Timing	1	
Performs	Define BSW Types	1	
Performs	Define Memory Addressing Modes	1	
Performs	Develop BSW Module Generator	1	
Performs	Generate BSW Module Prebuild Data Set	1	
Performs	Generate BSWM Contract Header Files	1	
Performs	Implement a BSW Module	1	
Performs	Configure Memmap Allocation	0..1	
Performs	Define Vendor Specific Module Definition	0..1	
Performs	Generate BSW Memory Mapping Header	0..1	
Performs	Generate Compiler Configuration	0..1	
Performs	Measure Component Resources	0..1	

**Table 3.32: Basic Software Module Developer**

<b>Role</b>	<b>Calibration Engineer</b>		
<b>Package</b>	AUTOSAR Root::M2::Methodology::Methodology Library::Common Elements::Roles		
<b>Brief Description</b>	The calibration engineer determines the calibration parameters of an ECU.		
<b>Description</b>			
<b>Relation Type</b>	<b>Related Element</b>	<b>Mul.</b>	<b>Note</b>

<i>Relation Type</i>	<i>Related Element</i>	<i>Mul.</i>	<i>Note</i>
Performs	Define VFB Parameter Component	1	
Performs	Generate A2L	1	
Performs	Create MC Function Model	0..1	
Performs	Define VFB Constants	0..1	
Performs	Provide RTE Calibration Dataset	0..1	

**Table 3.33: Calibration Engineer**

<i>Role</i>	<i>Certification Agency</i>		
<i>Package</i>	AUTOSAR Root::M2::Methodology::Methodology Library::Common Elements::Roles		
<i>Brief Description</i>	The certification agency verifies the conformance of artifacts with respect to the standard artifacts defined by the autosar consortium.		
<i>Description</i>			
<i>Relation Type</i>	<i>Related Element</i>	<i>Mul.</i>	<i>Note</i>

**Table 3.34: Certification Agency**

<i>Role</i>	<i>ECU Integrator</i>		
<i>Package</i>	AUTOSAR Root::M2::Methodology::Methodology Library::Common Elements::Roles		
<i>Brief Description</i>	Integrates the complete software on an ECU.		
<i>Description</i>	Integrates the complete software on an ECU, which includes generating necessary code and completing the configuration of all software components and basic software modules.		
<i>Relation Type</i>	<i>Related Element</i>	<i>Mul.</i>	<i>Note</i>
Performs	Compile ECU Source Code	1	
Performs	Configure Com	1	
Performs	Configure Debug	1	
Performs	Configure Diagnostics	1	
Performs	Configure ECUC	1	
Performs	Configure IO Hardware abstraction	1	
Performs	Configure MCAL	1	
Performs	Configure Mode Management	1	
Performs	Configure NvM	1	
Performs	Configure OS	1	
Performs	Configure RTE	1	

<b>Relation Type</b>	<b>Related Element</b>	<b>Mul.</b>	<b>Note</b>
Performs	Configure Watch-dog Manager	1	
Performs	Connect Service Component	1	
Performs	Create Library	1	
Performs	Create Service Component	1	
Performs	Define ECU Timing	1	
Performs	Define Integration Variant	1	
Performs	Extract the ECU Communication	1	
Performs	Generate BSW Configuration Code	1	
Performs	Generate BSW Memory Mapping Header	1	
Performs	Generate Base Ecu Configuration	1	
Performs	Generate Compiler Configuration	1	
Performs	Generate ECU Executable	1	
Performs	Generate Local M C Data Support	1	
Performs	Generate OS	1	
Performs	Generate RTE	1	
Performs	Generate RTE Postbuild Dataset	1	
Performs	Generate RTE Prebuild Dataset	1	
Performs	Generate SWC Memory Mapping Header	1	
Performs	Generate Scheduler	1	
Performs	Measure Resources	1	
Performs	Provide RTE Calibration Dataset	1	
Performs	Configure Memmap Allocation	0..1	
Performs	Create MC Function Model	0..1	
Performs	Extend Topology	0..1	

<b>Relation Type</b>	<b>Related Element</b>	<b>Mul.</b>	<b>Note</b>
Performs	Extract ECU System Timing	0..1	
Performs	Extract ECU System Variant Model	0..1	
Performs	Extract ECU Topology	0..1	
Performs	Flatten Software Composition	0..1	
Performs	Generate Component Header File in Vendor Mode	0..1	
Performs	Generate or Adjust ECU Flat Map	0..1	
Performs	Map Software Component to BS W	0..1	
Performs	Measure Component Resources	0..1	

**Table 3.35: ECU Integrator**

<b>Role</b>	<b>Software Component Designer</b>		
<b>Package</b>	AUTOSAR Root::M2::Methodology::Methodology Library::Common Elements::Roles		
<b>Brief Description</b>	Designer of software components and VFB systems.		
<b>Description</b>			
<b>Relation Type</b>	<b>Related Element</b>	<b>Mul.</b>	<b>Note</b>
Performs	Add Documentation to the Software Component	1	
Performs	Define Atomic Software Component Internal Behavior	1	
Performs	Define Complex Driver Component	1	
Performs	Define Consistency Needs	1	
Performs	Define E2E Protection Set for Swc	1	
Performs	Define ECU Abstraction Component	1	
Performs	Define VFB Application Software Component	1	
Performs	Define VFB Composition Component	1	

<i>Relation Type</i>	<i>Related Element</i>	<i>Mul.</i>	<i>Note</i>
Performs	Define VFB Constants	1	
Performs	Define VFB Interfaces	1	
Performs	Define VFB Modes	1	
Performs	Define VFB Sensor or Actuator Component	1	
Performs	Define VFB Timing	1	
Performs	Define VFB Types	1	
Performs	Define VFB Variants	1	
Performs	Define Wrapper Components to Integrate Legacy Software	1	
Performs	Map Software Component to BS W	1	
Performs	Define Partial Flat Map	0..1	
Performs	Define VFB Component Constraints	0..1	
Performs	Define VFB Top Level	0..1	

**Table 3.36: Software Component Designer**

<b>Role</b>	<b>Software Component Developer</b>		
<b>Package</b>	AUTOSAR Root::M2::Methodology::Methodology Library::Common Elements::Roles		
<b>Brief Description</b>	Developer of the software component code.		
<b>Description</b>			
<i>Relation Type</i>	<i>Related Element</i>	<i>Mul.</i>	<i>Note</i>
Performs	Compile Atomic Software Component	1	
Performs	Define Consistency Needs	1	
Performs	Define Software Component Timing	1	
Performs	Define Symbol Props for Types	1	
Performs	Generate Atomic Software Component Contract Header Files	1	

<i>Relation Type</i>	<i>Related Element</i>	<i>Mul.</i>	<i>Note</i>
Performs	Generate Component Header File in Vendor Mode	1	
Performs	Generate Component Prebuild Data Set	1	
Performs	Implement Atomic Software Component	1	
Performs	Measure Component Resources	1	
Performs	Re-compile Component in ECU context	1	
Performs	Add Documentation to the Software Component	0..1	
Performs	Configure Compiler Memory Classes	0..1	
Performs	Configure Memmap Allocation	0..1	
Performs	Define Atomic Software Component Internal Behavior	0..1	
Performs	Define Memory Addressing Modes	0..1	
Performs	Define Partial Flat Map	0..1	
Performs	Generate Compiler Configuration	0..1	
Performs	Generate E2E Protection Wrapper	0..1	
Performs	Generate SWC Memory Mapping Header	0..1	

**Table 3.37: Software Component Developer**

<b>Role</b>	<b>System Engineer</b>		
<b>Package</b>	AUTOSAR Root::M2::Methodology::Methodology Library::Common Elements::Roles		
<b>Brief Description</b>	Creation, management, development and integration of systems within the vehicle		
<b>Description</b>			
<b>Relation Type</b>	<b>Related Element</b>	<b>Mul.</b>	<b>Note</b>
Performs	Assign Top Level Composition	1	



<b>Relation Type</b>	<b>Related Element</b>	<b>Mul.</b>	<b>Note</b>
Performs	Define Communication Matrix	1	
Performs	Define ECU Description	1	
Performs	Define Frames	1	
Performs	Define Network Management	1	
Performs	Define PDU Gateway	1	
Performs	Define RTE Fan-out	1	
Performs	Define Signal Gateway	1	
Performs	Define Signal PDUs	1	
Performs	Define Signal Path Constraints	1	
Performs	Define Software Component Mapping Constraints	1	
Performs	Define System Timing	1	
Performs	Define System Topology	1	
Performs	Define System Variants	1	
Performs	Define System View Mapping	1	
Performs	Define TP	1	
Performs	Deploy Software Component	1	
Performs	Derive Communication Needs	1	
Performs	Extend Composition	1	
Performs	Extract the ECU Communication	1	
Performs	Flatten Software Composition	1	
Performs	Generate or Adjust System Flat Map	1	
Performs	Select Design Time Variant	1	
Performs	Select Software Component Implementation	1	
Performs	Set System Root	1	
Performs	Define VFB Component Constraints	0..1	

<i>Relation Type</i>	<i>Related Element</i>	<i>Mul.</i>	<i>Note</i>
Performs	Define VFB Composition Component	0..1	
Performs	Define VFB Constants	0..1	
Performs	Define VFB Top Level	0..1	
Performs	Extend Topology	0..1	
Performs	Extract ECU System Timing	0..1	
Performs	Extract ECU System Variant Model	0..1	
Performs	Extract ECU Topology	0..1	
Performs	Generate or Adjust ECU Flat Map	0..1	

**Table 3.38: System Engineer**

### 3.1.5 Tools

#### 3.1.5.1 Compiler

<i>Tool</i>	<b>Compiler</b>		
<i>Package</i>	AUTOSAR Root::M2::Methodology::Methodology Library::Common Elements::Guidance		
<i>Brief Description</i>			
<i>Description</i>			
<i>Kind</i>			
<i>Relation Type</i>	<i>Related Element</i>	<i>Mul.</i>	<i>Note</i>
Used	Compile Atomic Software Component	1	
Used	Compile BSW Configuration Data	1	
Used	Compile BSW Core Code	1	
Used	Compile Configured BSW	1	
Used	Compile ECU Source Code	1	
Used	Compile Generated BSW	1	
Used	Compile Unconfigured BSW	1	
Used	Re-compile Component in ECU context	1	

<i>Relation Type</i>	<i>Related Element</i>	<i>Mul.</i>	<i>Note</i>
----------------------	------------------------	-------------	-------------

**Table 3.39: Compiler**

### 3.1.5.2 Linker

<i>Tool</i>	<b>Linker</b>		
<b>Package</b>	AUTOSAR Root::M2::Methodology::Methodology Library::Common Elements::Guidance		
<b>Brief Description</b>			
<b>Description</b>			
<b>Kind</b>			
<i>Relation Type</i>	<i>Related Element</i>	<i>Mul.</i>	<i>Note</i>
Used	Generate ECU Executable	1	
Used	Link ECU Code after Precompile Configuration	1	
Used	Link ECU Code during Link Time Configuration	1	
Used	Link ECU Code during Post-Build Time Loadable	1	
Used	Link ECU Code during Post-build Time Selectable	1	

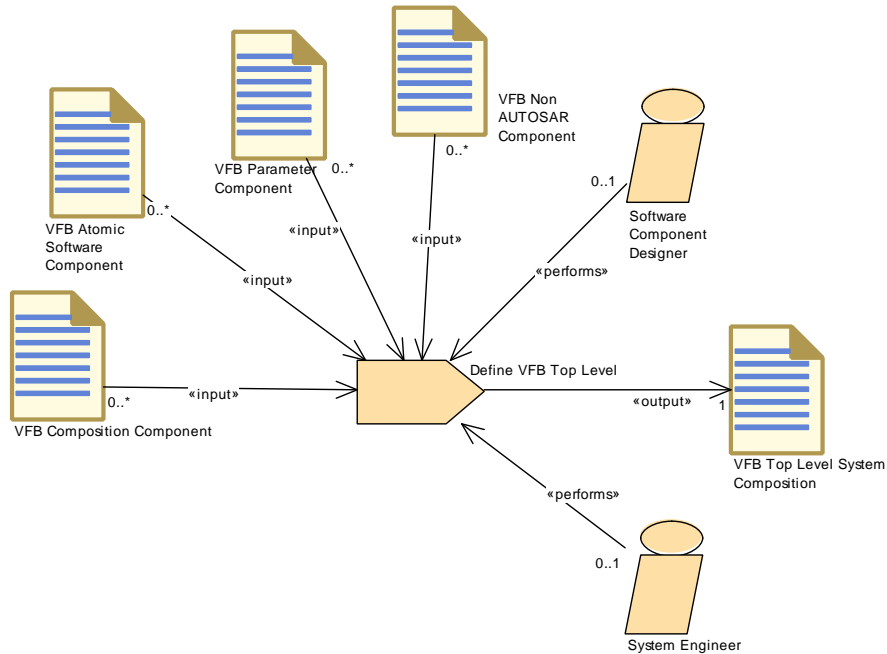
**Table 3.40: Linker**

## 3.2 Virtual Functional Bus

This chapter contains the definition of work products and tasks used for the development of a VFB system. For the definition of the relevant meta-model elements refer to [4], for the VFB concepts refer to [3].

### 3.2.1 Tasks

#### 3.2.1.1 Define VFB Top Level



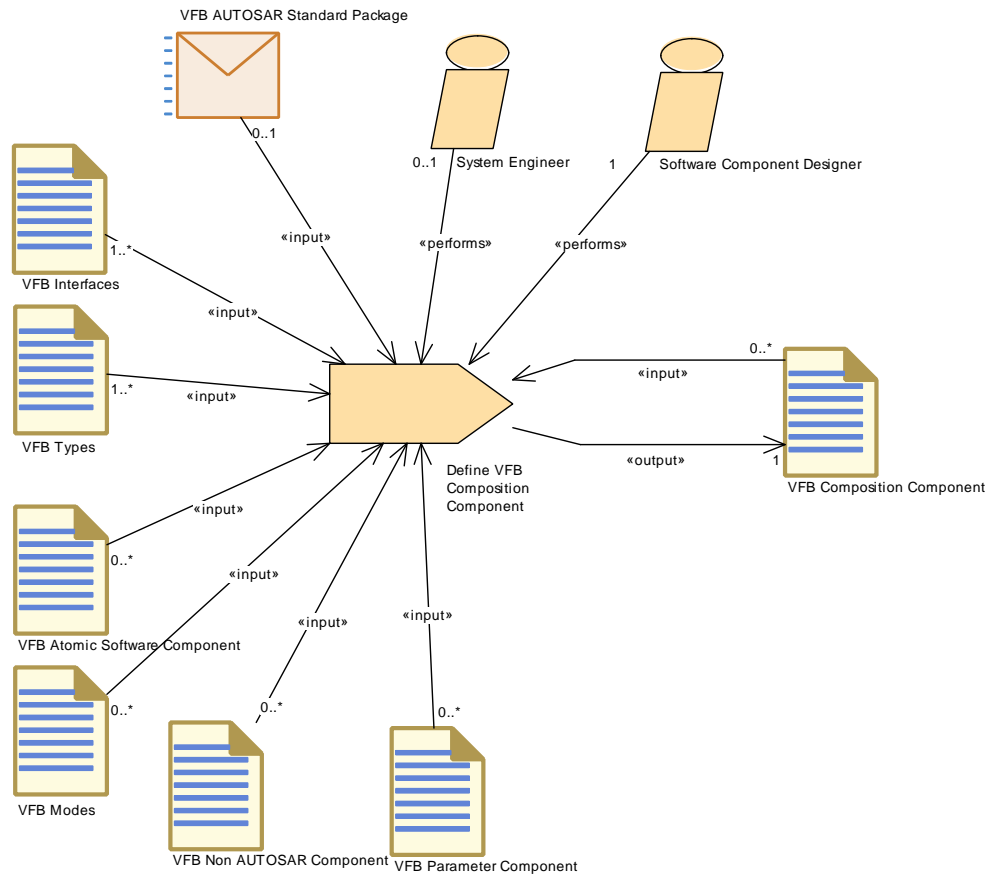
**Figure 3.12: Task Define VFB Top Level**

<b>Task Definition</b>	<b>Define VFB Top Level</b>		
<b>Package</b>	AUTOSAR Root::M2::Methodology::Methodology Library::VFB::Tasks		
<b>Brief Description</b>	Define the top level VFB composition of a concrete system.		
<b>Description</b>	Define the top level composition of a VFB system.		
<b>Relation Type</b>	<b>Related Element</b>	<b>Mul.</b>	<b>Note</b>
Performed by	Software Component Designer	0..1	
Performed by	System Engineer	0..1	
Consumes	VFB Interfaces	1..*	
Consumes	VFB Types	1..*	
Consumes	E2E Protection Set	0..1	
Consumes	VFB Atomic Software Component	0..*	
Consumes	VFB Composition Component	0..*	
Consumes	VFB Modes	0..*	
Consumes	VFB Non AUTOSAR Component	0..*	
Consumes	VFB Parameter Component	0..*	
Produces	VFB Top Level System Composition	1	

Relation Type	Related Element	Mul.	Note
---------------	-----------------	------	------

**Table 3.41: Define VFB Top Level**

**3.2.1.2 Define VFB Composition Component**



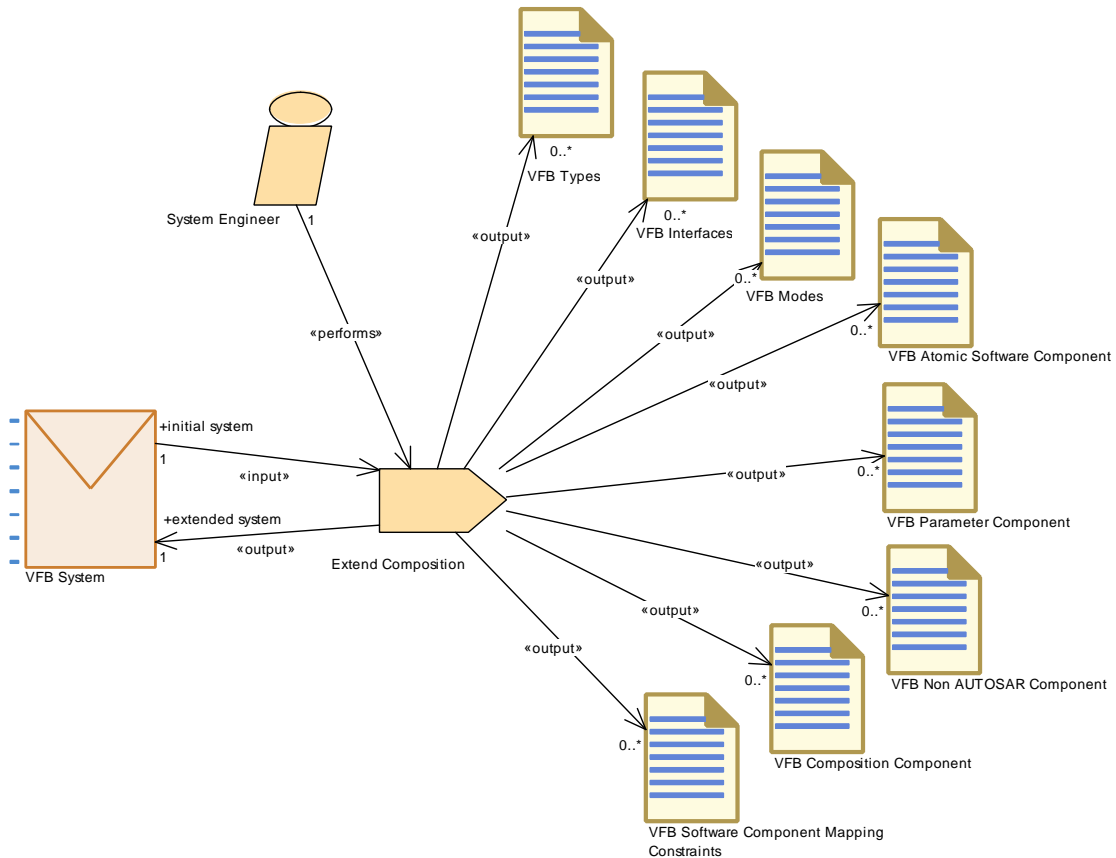
**Figure 3.13: Task Define VFB Composition Component**

Task Definition	Define VFB Composition Component		
Package	AUTOSAR Root::M2::Methodology::Methodology Library::VFB::Tasks		
Brief Description	Define a Composition of VFB Software Components, i.e. a ComponentTypes which contains other Component Types.		
Description	Define a Composition of VFB Software Components, i.e. a ComponentType which contains other Component Types. Iteration of this task can create a complete VFB system without the Atomic Software Components itself.		
Relation Type	Related Element	Mul.	Note
Performed by	Software Component Designer	1	
Performed by	System Engineer	0..1	
Consumes	VFB Interfaces	1..*	
Consumes	VFB Types	1..*	

Relation Type	Related Element	Mul.	Note
Consumes	VFB AUTOSAR Standard Package	0..1	Use port blueprints in order to create ports with standardized application interfaces.
Consumes	VFB Atomic Software Component	0..*	
Consumes	VFB Composition Component	0..*	
Consumes	VFB Modes	0..*	
Consumes	VFB Non AUTOSAR Component	0..*	
Consumes	VFB Parameter Component	0..*	
Produces	VFB Composition Component	1	

**Table 3.42: Define VFB Composition Component**

**3.2.1.3 Extend Composition**

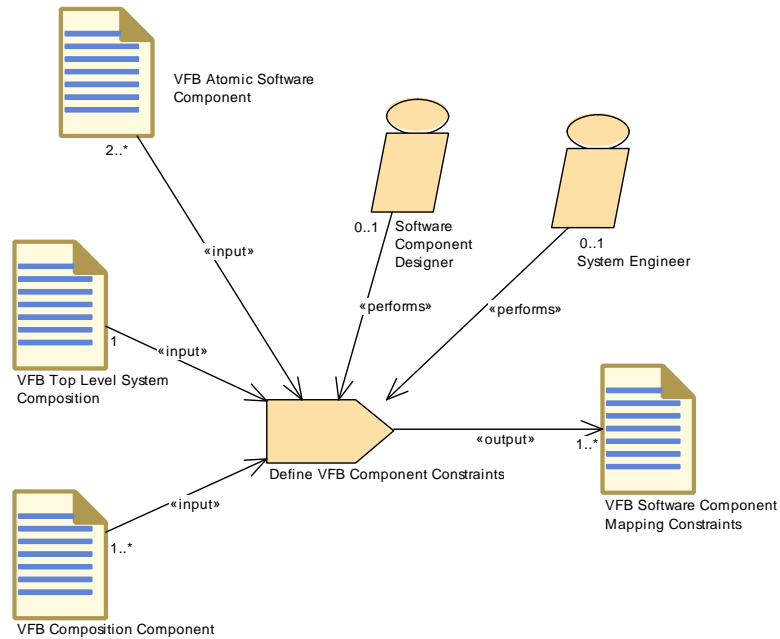


**Figure 3.14: Task Extend Composition**

<b>Task Definition</b>	<b>Extend Composition</b>		
<b>Package</b>	AUTOSAR Root::M2::Methodology::Methodology Library::VFB::Tasks		
<b>Brief Description</b>	Extend a software composition with further compositions and atomic software components.		
<b>Description</b>	<p>This tasks describes the refinement of a delivered VFB System by extending an existing composition with further sub-elements, which could be software components (Atomic Software Components as well as Compositions), connectors or port groups, plus the related interfaces, data types and modes.</p> <p>The main use case is the refinement of the VFB description of a sub-system: New elements are added but the original delivery is not changed.</p>		
<b>Relation Type</b>	<b>Related Element</b>	<b>Mul.</b>	<b>Note</b>
Performed by	System Engineer	1	
Consumes	VFB System	1	initial system:
Produces	VFB System	1	extended system:
Produces	VFB Atomic Software Component	0..*	
Produces	VFB Composition Component	0..*	
Produces	VFB Interfaces	0..*	
Produces	VFB Modes	0..*	
Produces	VFB Non AUTOSAR Component	0..*	
Produces	VFB Parameter Component	0..*	
Produces	VFB Software Component Mapping Constraints	0..*	
Produces	VFB Types	0..*	

**Table 3.43: Extend Composition**

**3.2.1.4 Define VFB Component Constraints**



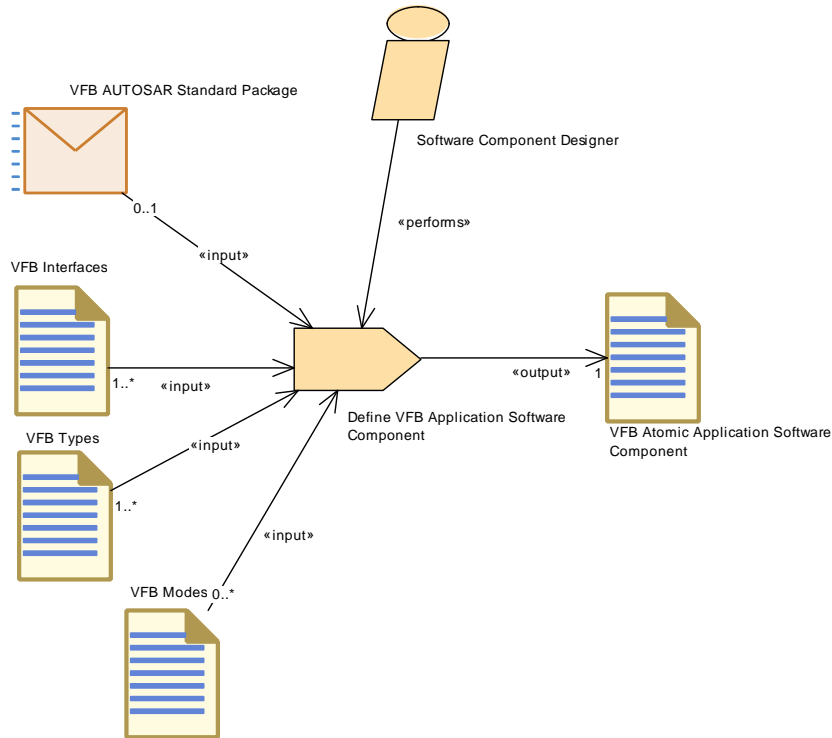
**Figure 3.15: Task Define VFB Component Constraints**

<b>Task Definition</b>	<b>Define VFB Component Constraints</b>		
<b>Package</b>	AUTOSAR Root::M2::Methodology::Methodology Library::VFB::Tasks		
<b>Brief Description</b>	Define which components need to be deployed together, and which need to be deployed separately.		
<b>Description</b>	Define which components need to be deployed together, and which need to be deployed separately, independent of any topology.		
<b>Relation Type</b>	<b>Related Element</b>	<b>Mul.</b>	<b>Note</b>
Performed by	Software Component Designer	0..1	
Performed by	System Engineer	0..1	
Consumes	VFB Atomic Software Component	2..*	
Consumes	VFB Top Level System Composition	1	
Consumes	VFB Composition Component	1..*	
Produces	VFB Software Component Mapping Constraints	1..*	

**Table 3.44: Define VFB Component Constraints**



### 3.2.1.5 Define VFB Application Software Component

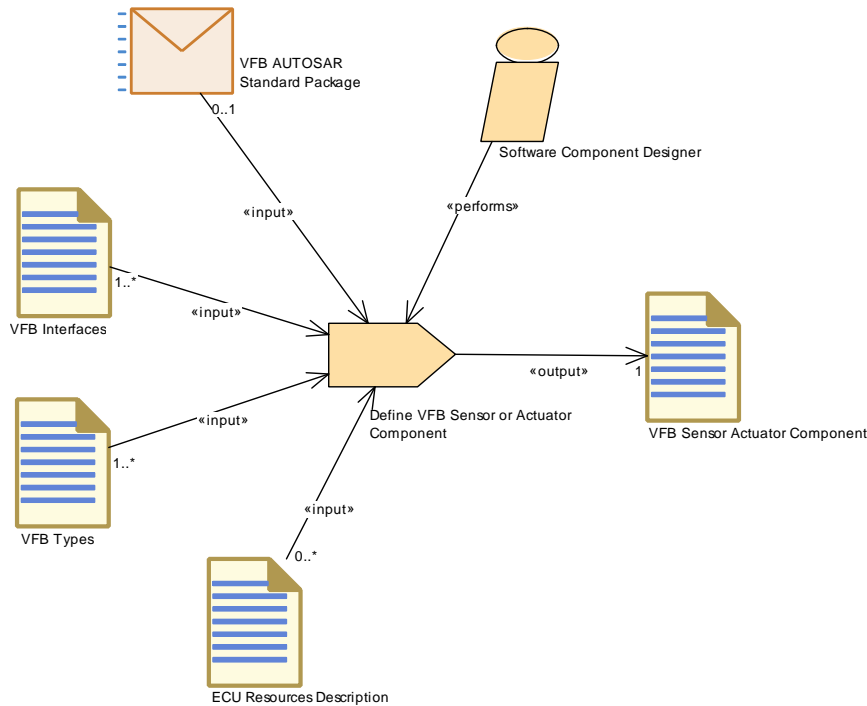


**Figure 3.16: Task Define VFB Application Software Component**

<b>Task Definition</b>	<b>Define VFB Application Software Component</b>		
<b>Package</b>	AUTOSAR Root::M2::Methodology::Methodology Library::VFB::Tasks		
<b>Brief Description</b>	Define an ApplicationSoftwareComponentType on VFB level		
<b>Description</b>	Define an ApplicationSwComponentType on VFB level. (i.e. without Internal Behavior and Implementation).		
<b>Relation Type</b>	<b>Related Element</b>	<b>Mul.</b>	<b>Note</b>
Performed by	<a href="#">Software Component Designer</a>	1	
Consumes	<a href="#">VFB Interfaces</a>	1..*	
Consumes	<a href="#">VFB Types</a>	1..*	
Consumes	<a href="#">VFB AUTOSAR Standard Package</a>	0..1	Use port blueprints in order to create ports with standardized application interfaces.
Consumes	<a href="#">VFB Modes</a>	0..*	
Produces	<a href="#">VFB Atomic Application Software Component</a>	1	

**Table 3.45: Define VFB Application Software Component**

### 3.2.1.6 Define VFB Sensor or Actuator Component

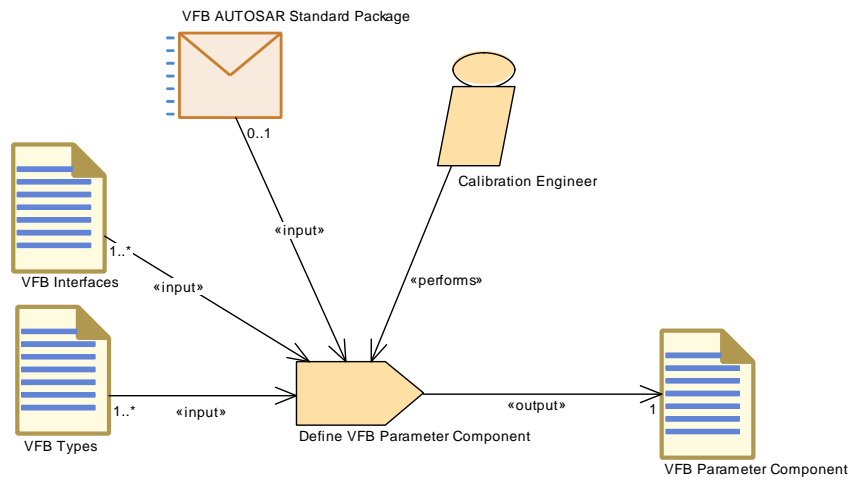


**Figure 3.17: Task Define VFB Sensor or Actuator Component**

<b>Task Definition</b>	<b>Define VFB Sensor or Actuator Component</b>		
<b>Package</b>	AUTOSAR Root::M2::Methodology::Methodology Library::VFB::Tasks		
<b>Brief Description</b>	Define a VFB Sensor or Actuator Component.		
<b>Description</b>	Define a SensorActuatorSwComponentType on VFB level. (i.e. without Internal Behavior and Implementation). In addition to defining the ports, references to the required sensor/actuator hardware shall be specified.		
<b>Relation Type</b>	<b>Related Element</b>	<b>Mul.</b>	<b>Note</b>
Performed by	Software Component Designer	1	
Consumes	VFB Interfaces	1..*	
Consumes	VFB Types	1..*	
Consumes	VFB AUTOSAR Standard Package	0..1	Use port blueprints in order to create ports with standardized application interfaces.
Consumes	ECU Resources Description	0..*	
Produces	VFB Sensor Actuator Component	1	

**Table 3.46: Define VFB Sensor or Actuator Component**

### 3.2.1.7 Define VFB Parameter Component

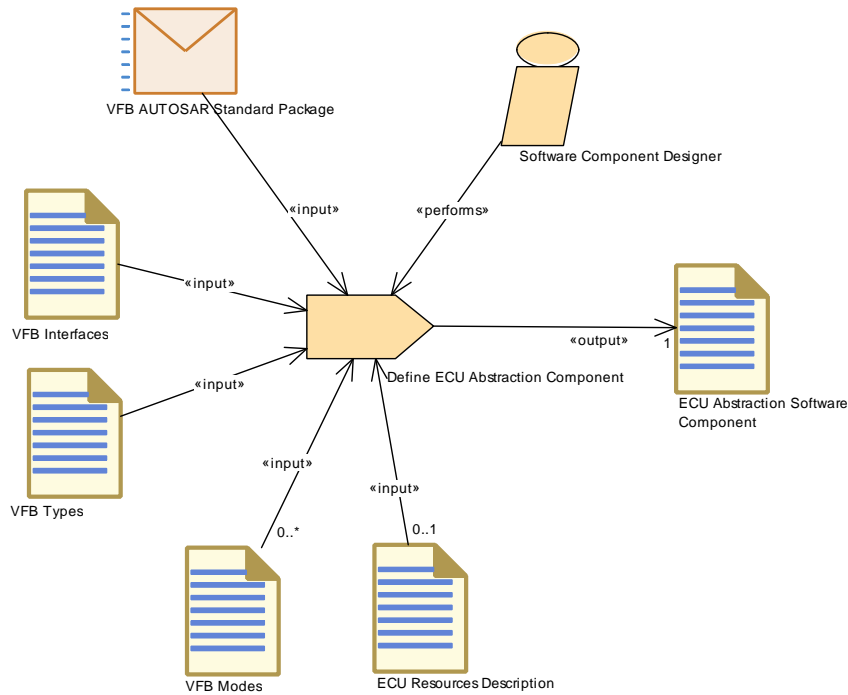


**Figure 3.18: Task Define VFB Parameter Component**

<b>Task Definition</b>	<b>Define VFB Parameter Component</b>		
<b>Package</b>	AUTOSAR Root::M2::Methodology::Methodology Library::VFB::Tasks		
<b>Brief Description</b>	Define a VFB Parameter Component.		
<b>Description</b>	Define a VFB Parameter Component.		
<b>Relation Type</b>	<b>Related Element</b>	<b>Mul.</b>	<b>Note</b>
Performed by	Calibration Engineer	1	
Consumes	VFB Interfaces	1..*	
Consumes	VFB Types	1..*	
Consumes	VFB AUTOSAR Standard Package	0..1	Use port blueprints in order to create ports with standardized application interfaces.
Produces	VFB Parameter Component	1	

**Table 3.47: Define VFB Parameter Component**

### 3.2.1.8 Define ECU Abstraction Component

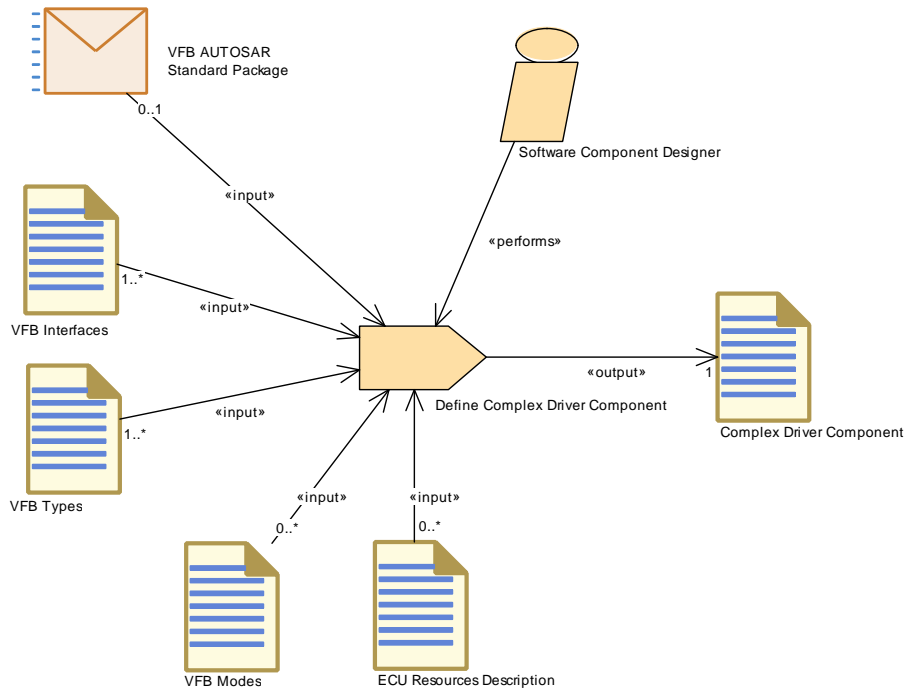


**Figure 3.19: Task Define ECU Abstraction Component**

<b>Task Definition</b>	<b>Define ECU Abstraction Component</b>		
<b>Package</b>	AUTOSAR Root::M2::Methodology::Methodology Library::VFB::Tasks		
<b>Brief Description</b>	Define an EcuAbstractionSoftwareComponentType on VFB level.		
<b>Description</b>	Define a EcuAbstractionSwComponentType on VFB level. (i.e. without Internal Behavior and Implementation). In addition to the defining the ports, references to required ECU or processor hardware elements shall be specified.		
<b>Relation Type</b>	<b>Related Element</b>	<b>Mul.</b>	<b>Note</b>
Performed by	Software Component Designer	1	
Consumes	VFB AUTOSAR Standard Package	1	Use port blueprints in order to create ports with standardized application interfaces.
Consumes	VFB Interfaces	1	
Consumes	VFB Types	1	
Consumes	ECU Resources Description	0..1	
Consumes	VFB Modes	0..*	
Produces	ECU Abstraction Software Component	1	

**Table 3.48: Define ECU Abstraction Component**

### 3.2.1.9 Define Complex Driver Component

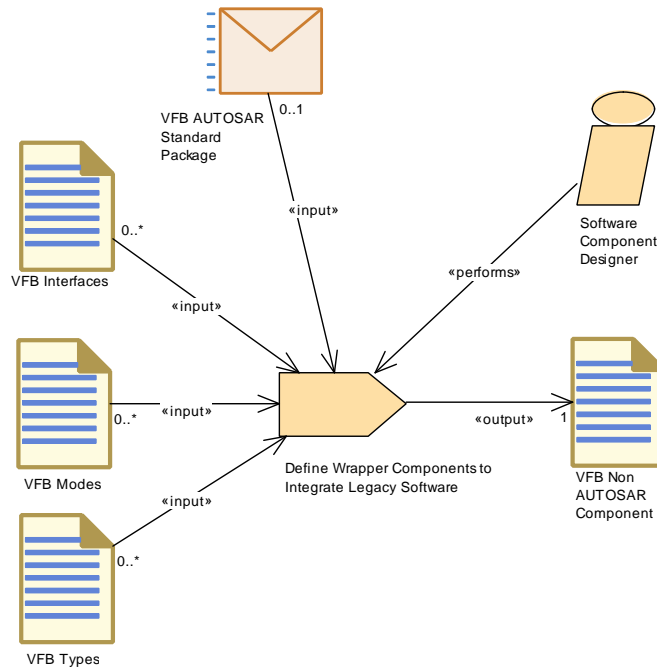


**Figure 3.20: Task Define Complex Driver Component**

<b>Task Definition</b>	<b>Define Complex Driver Component</b>		
<b>Package</b>	AUTOSAR Root::M2::Methodology::Methodology Library::VFB::Tasks		
<b>Brief Description</b>	Define a ComplexDeviceDriverSwComponentType on VFB level.		
<b>Description</b>	Define a ComplexDeviceDriverSwComponentType on VFB level. (i.e. without Internal Behavior and Implementation). In addition to the defining the ports, references to the required ECU or processor hardware elements shall be specified.		
<b>Relation Type</b>	<b>Related Element</b>	<b>Mul.</b>	<b>Note</b>
Performed by	Software Component Designer	1	
Consumes	VFB Interfaces	1..*	
Consumes	VFB Types	1..*	
Consumes	VFB AUTOSAR Standard Package	0..1	Use port blueprints in order to create ports with standardized application interfaces.
Consumes	ECU Resources Description	0..*	
Consumes	VFB Modes	0..*	
Produces	Complex Driver Component	1	

**Table 3.49: Define Complex Driver Component**

**3.2.1.10 Define Wrapper Components to Integrate Legacy Software**

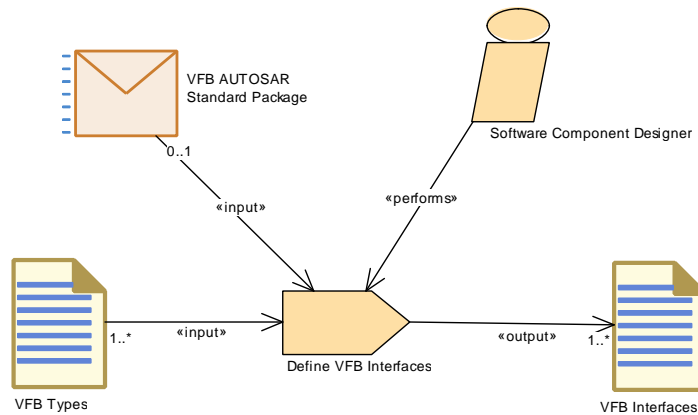


**Figure 3.21: Task Define Wrapper Components to Integrate Legacy Software**

<b>Task Definition</b>	<b>Define Wrapper Components to Integrate Legacy Software</b>		
<b>Package</b>	AUTOSAR Root::M2::Methodology::Methodology Library::VFB::Tasks		
<b>Brief Description</b>	Define a wrapper component used to represent legacy software that is integrated into an AUTOSAR system.		
<b>Description</b>	Define a wrapper component used to represent legacy software that is integrated into an AUTOSAR system. For the VFB system, this mainly means to define the corresponding port interfaces and data elements.		
<b>Relation Type</b>	<b>Related Element</b>	<b>Mul.</b>	<b>Note</b>
Performed by	<a href="#">Software Component Designer</a>	1	
Consumes	<a href="#">VFB AUTOSAR Standard Package</a>	0..1	Use port blueprints in order to create ports with standardized application interfaces.
Consumes	<a href="#">VFB Interfaces</a>	0..*	
Consumes	<a href="#">VFB Modes</a>	0..*	
Consumes	<a href="#">VFB Types</a>	0..*	
Produces	<a href="#">VFB Non AUTOSAR Component</a>	1	

**Table 3.50: Define Wrapper Components to Integrate Legacy Software**

**3.2.1.11 Define VFB Interfaces**

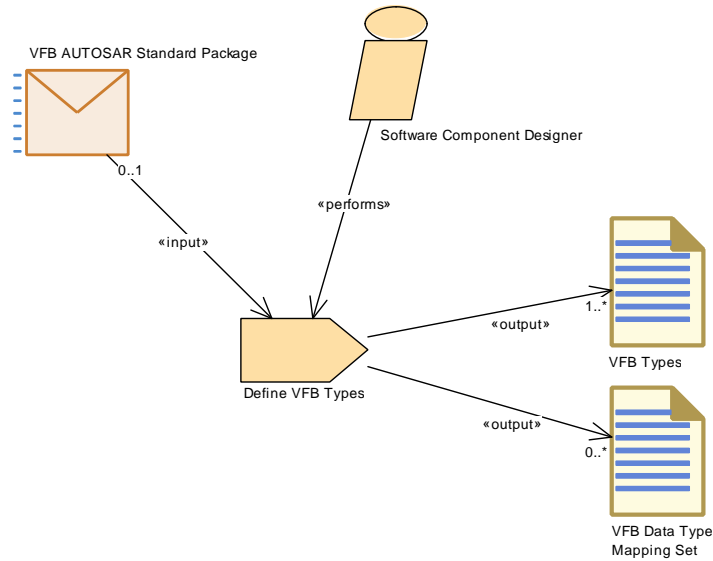


**Figure 3.22: Task Define VFB Interfaces**

<b>Task Definition</b>	<b>Define VFB Interfaces</b>		
<b>Package</b>	AUTOSAR Root::M2::Methodology::Methodology Library::VFB::Tasks		
<b>Brief Description</b>	Define a set of Port Interface required by a system.		
<b>Description</b>	Define a set of Port Interfaces required by a VFB system, to describe the communication of data via SWC ports.		
<b>Relation Type</b>	<b>Related Element</b>	<b>Mul.</b>	<b>Note</b>
Performed by	Software Component Designer	1	
Consumes	VFB Types	1..*	
Consumes	VFB AUTOSAR Standard Package	0..1	Use standardized Port Interfaces as blueprints (as far as applicable) to create the corresponding elements of the actual project.
Produces	VFB Interfaces	1..*	

**Table 3.51: Define VFB Interfaces**

**3.2.1.12 Define VFB Types**



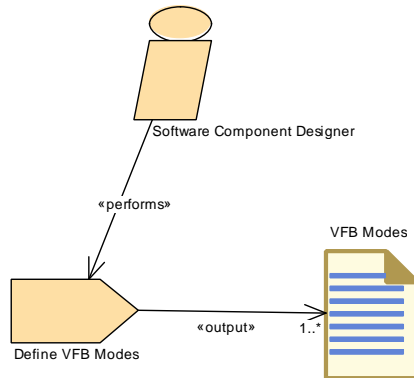
**Figure 3.23: Task Define VFB Types**

<b>Task Definition</b>	<b>Define VFB Types</b>		
<b>Package</b>	AUTOSAR Root::M2::Methodology::Methodology Library::VFB::Tasks		
<b>Brief Description</b>	Define a set of data types required by a system, but not already defined by AUTOSAR.		
<b>Description</b>	<p>Define a set of Autosar Data Types and related elements as far as visible on the VFB. Standardized types can be used as input in order to copy and refine them.</p> <p>The VFB Types will be used for specifying types of DataElements in Sender-Receiver PortInterfaces and argument/return values of Client-Server PortInterfaces.</p> <p>This task includes (optionally) also the creation of a VFB Data Type mapping Set between application and implementation data types.</p>		
<b>Relation Type</b>	<b>Related Element</b>	<b>Mul.</b>	<b>Note</b>
Performed by	Software Component Designer	1	
Consumes	VFB AUTOSAR Standard Package	0..1	Use standardized elements (e.g. Data Types, Compu Methods) as blueprints (as far as applicable) to create the corresponding elements of the actual project.
Produces	VFB Types	1..*	
Produces	VFB Data Type Mapping Set	0..*	

**Table 3.52: Define VFB Types**



**3.2.1.13 Define VFB Modes**

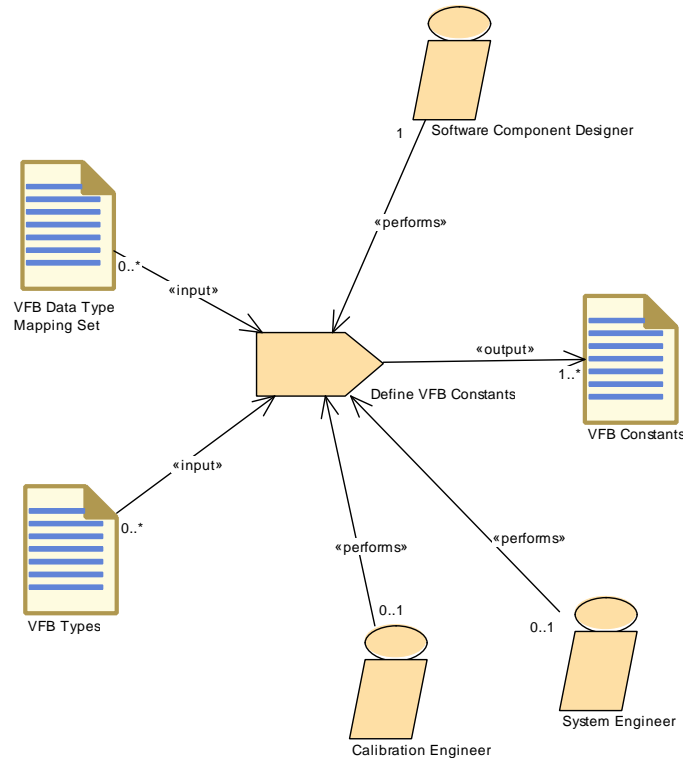


**Figure 3.24: Task Define VFB Modes**

<b>Task Definition</b>	<b>Define VFB Modes</b>		
<b>Package</b>	AUTOSAR Root::M2::Methodology::Methodology Library::VFB::Tasks		
<b>Brief Description</b>	Define modes that are used by the VFB components.		
<b>Description</b>	Define modes (mode groups and the modes they contain) that are used by the VFB components.		
<b>Relation Type</b>	<b>Related Element</b>	<b>Mul.</b>	<b>Note</b>
Performed by	Software Component Designer	1	
Produces	VFB Modes	1..*	

**Table 3.53: Define VFB Modes**

**3.2.1.14 Define VFB Constants**

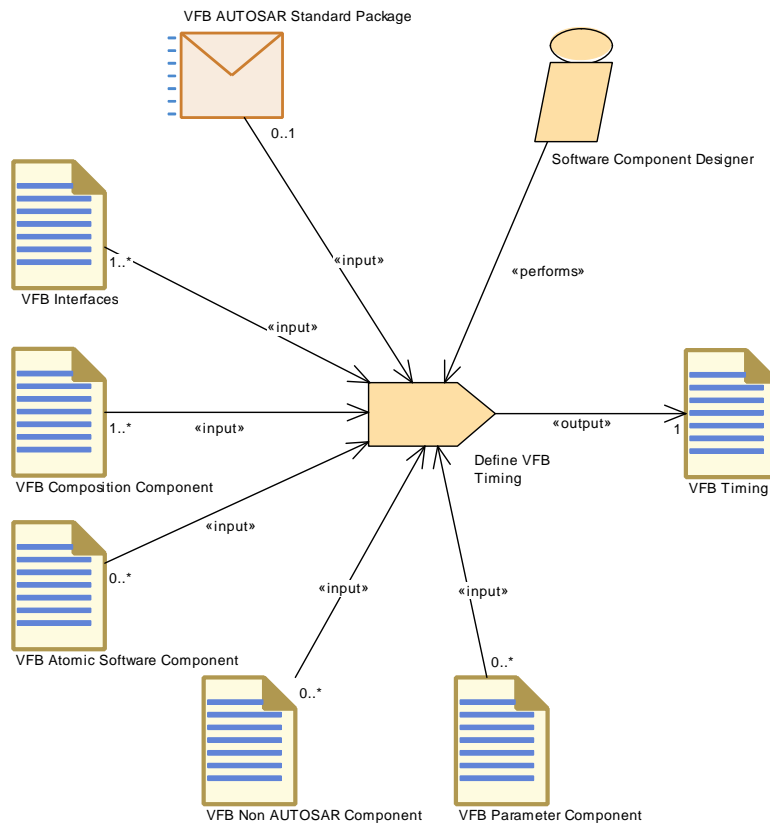


**Figure 3.25: Task Define VFB Constants**

<b>Task Definition</b>	<b>Define VFB Constants</b>		
<b>Package</b>	AUTOSAR Root::M2::Methodology::Methodology Library::VFB::Tasks		
<b>Brief Description</b>	Define one or more VFB Constants.		
<b>Description</b>	Define one or more VFB Constants as standalone artifact. Such constants can be referred in the specification of initial values at several places in the VFB description, such as port interfaces or declaration of local parameters or variables.		
<b>Relation Type</b>	<b>Related Element</b>	<b>Mul.</b>	<b>Note</b>
Performed by	Software Component Designer	1	
Performed by	Calibration Engineer	0..1	
Performed by	System Engineer	0..1	
Consumes	VFB Data Type Mapping Set	0..*	
Consumes	VFB Types	0..*	
Produces	VFB Constants	1..*	

**Table 3.54: Define VFB Constants**

### 3.2.1.15 Define VFB Timing



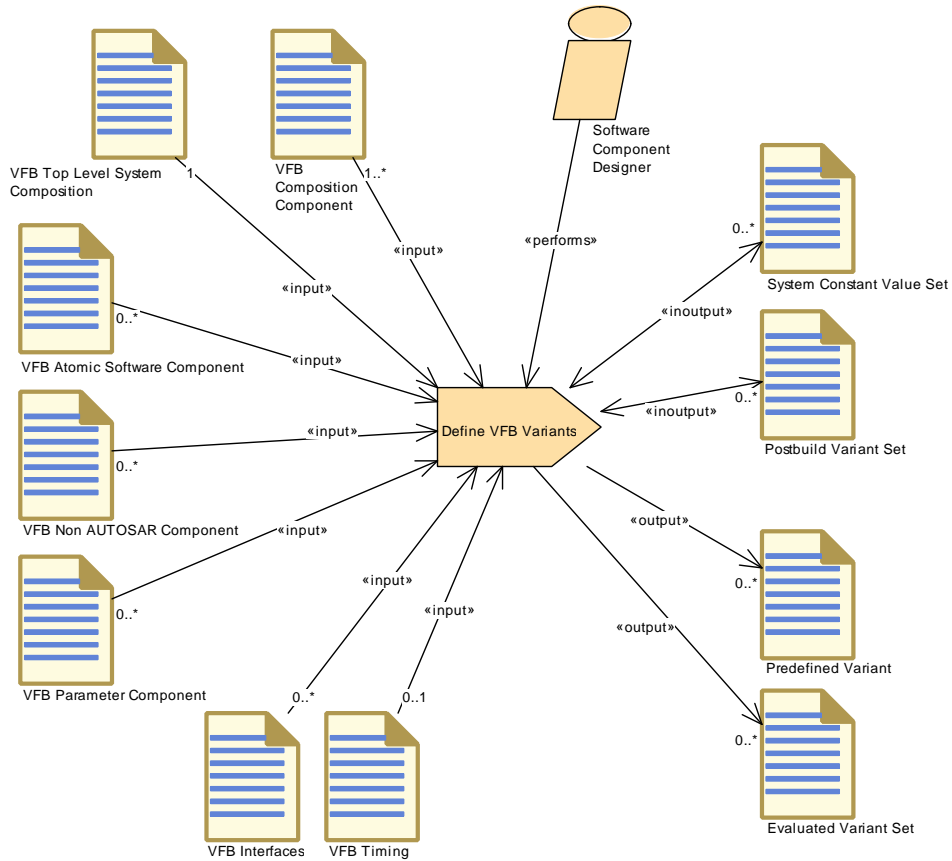
**Figure 3.26: Task Define VFB Timing**

<b>Task Definition</b>	<b>Define VFB Timing</b>		
<b>Package</b>	AUTOSAR Root::M2::Methodology::Methodology Library::VFB::Tasks		
<b>Brief Description</b>	Define VFB Timing (TimingDescription and TimingConstraints) for an Atomic Software Component or a Composition Component		
<b>Description</b>	Define VFB Timing (TimingDescription and TimingConstraints) for an Atomic Software Component or a Composition Component		
<b>Relation Type</b>	<b>Related Element</b>	<b>Mul.</b>	<b>Note</b>
Performed by	Software Component Designer	1	
Consumes	VFB Composition Component	1..*	
Consumes	VFB Interfaces	1..*	
Consumes	VFB AUTOSAR Standard Package	0..1	
Consumes	VFB Atomic Software Component	0..*	
Consumes	VFB Non AUTOSAR Component	0..*	
Consumes	VFB Parameter Component	0..*	
Produces	VFB Timing	1	

Relation Type	Related Element	Mul.	Note
---------------	-----------------	------	------

**Table 3.55: Define VFB Timing**

**3.2.1.16 Define VFB Variants**



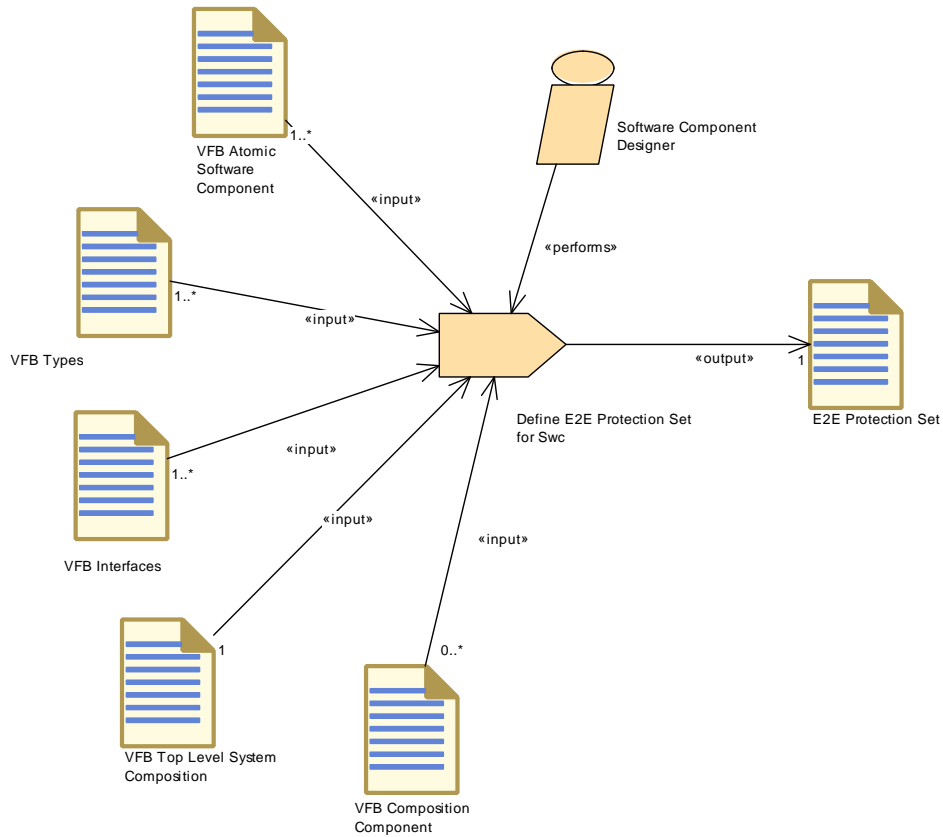
**Figure 3.27: Task Define VFB Variants**

<b>Task Definition</b>	<b>Define VFB Variants</b>		
<b>Package</b>	AUTOSAR Root::M2::Methodology::Methodology Library::VFB::Tasks		
<b>Brief Description</b>	Define variants for the artifacts of a VFB system.		
<b>Description</b>	<p>Define one or more variants for the artifacts of a VFB system. Defining one variant means creating a Predefined Variant related to the settings used by the VFB elements in scope. To do so, this task can make use of existing System Constant Value Sets and/or Postbuild Variant Sets or define new ones.</p> <p>Several Predefined Variants can be combined to one Evaluated Variant Set.</p>		
<b>Relation Type</b>	<b>Related Element</b>	<b>Mul.</b>	<b>Note</b>
Performed by	Software Component Designer	1	

<i>Relation Type</i>	<i>Related Element</i>	<i>Mul.</i>	<i>Note</i>
Consumes	VFB Top Level System Composition	1	
Consumes	VFB Composition Component	1..*	
Consumes	VFB Timing	0..1	
Consumes	VFB Atomic Software Component	0..*	
Consumes	VFB Interfaces	0..*	
Consumes	VFB Non AUTOSAR Component	0..*	
Consumes	VFB Parameter Component	0..*	
In/out	Postbuild Variant Set	0..*	
In/out	System Constant Value Set	0..*	
Produces	Evaluated Variant Set	0..*	
Produces	Predefined Variant	0..*	

**Table 3.56: Define VFB Variants**

**3.2.1.17 Define E2E Protection Set for Software Components**



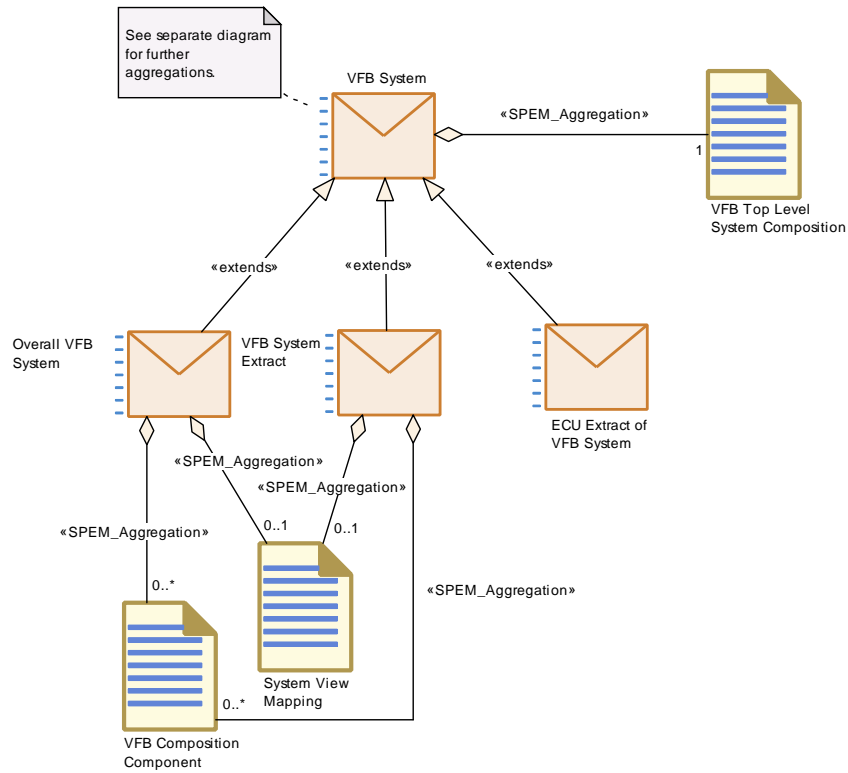
**Figure 3.28: Task Define E2E Protection Set for Software Components**

<i>Task Definition</i>	<b>Define E2E Protection Set for Swc</b>		
<b>Package</b>	AUTOSAR Root::M2::Methodology::Methodology Library::VFB::Tasks		
<b>Brief Description</b>			
<b>Description</b>	Define E2E Protection Set for Swc : Define all the constraints at the data level needed to generate the E2E wrapper. These shall be based on different profiles for different levels of safe communication.		
<i>Relation Type</i>	<i>Related Element</i>	<i>Mul.</i>	<i>Note</i>
Performed by	Software Component Designer	1	
Consumes	VFB Top Level System Composition	1	
Consumes	VFB Atomic Software Component	1..*	
Consumes	VFB Interfaces	1..*	
Consumes	VFB Types	1..*	
Consumes	VFB Composition Component	0..*	
Produces	E2E Protection Set	1	

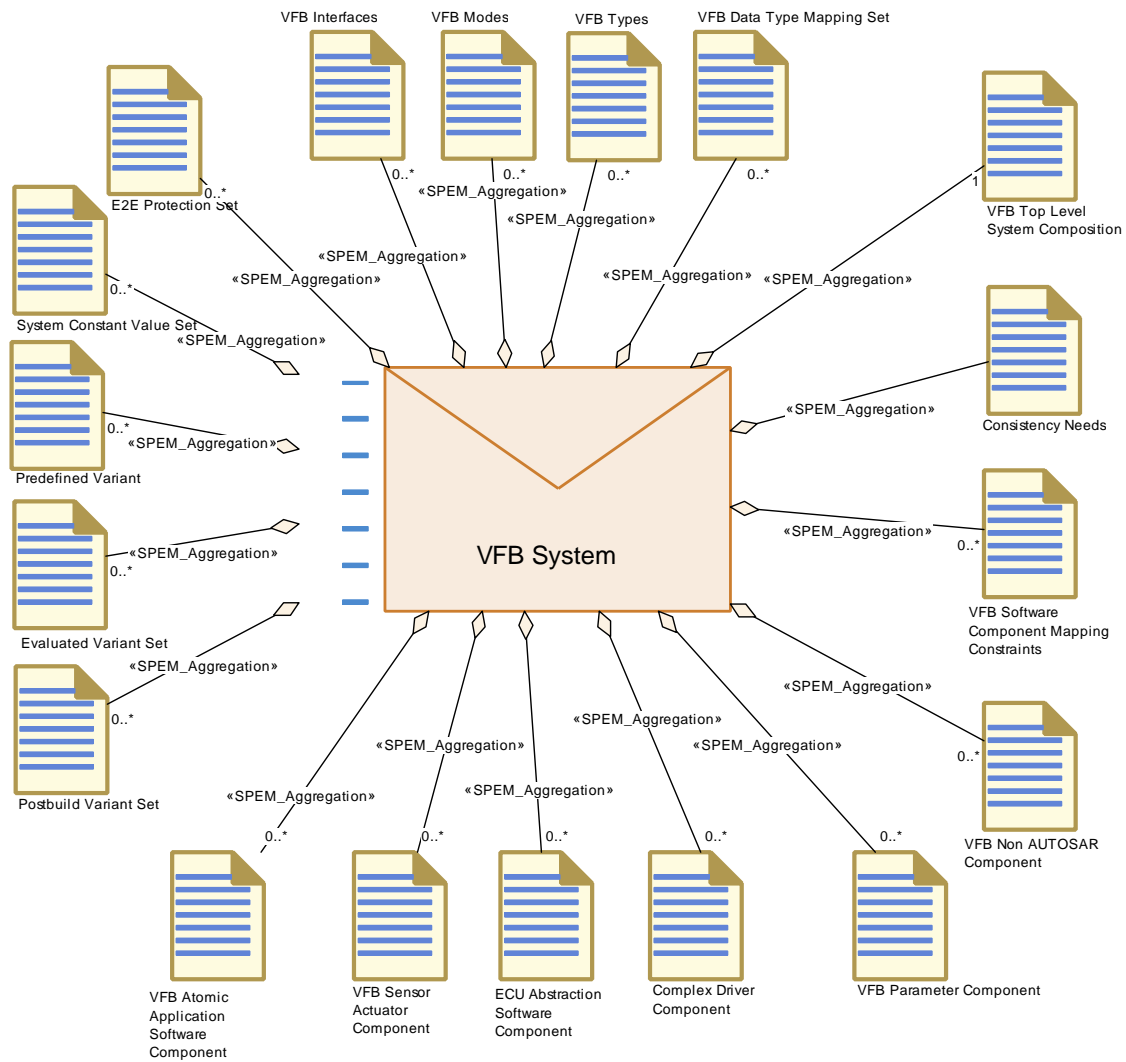
**Table 3.57: Define E2E Protection Set for Swc**

### 3.2.2 Work Products

#### 3.2.2.1 VFB System



**Figure 3.29: Overview on the different roles of Deliverables based on VFB System**



**Figure 3.30: Structure of Deliverable VFB System**

<b>Deliverable</b>	<b>VFB System</b>
<b>Package</b>	AUTOSAR Root::M2::Methodology::Methodology Library::VFB::Work Products
<b>Brief Description</b>	Complete VFB view of a concrete system.
<b>Description</b>	<p>Delivery of a VFB view of a concrete system. i.e. the top level composition and all nested compositions and components. This element is the basis for several extensions according to the scope of the VFB which can be an Overall System, a System Extract or an ECU Extract.</p> <p>This deliverable may contain variation points in its XML artifacts which need to be bound in later steps of the methodology. If such variation points are present, the delivered VFB system may optionally include PredefinedVariants in order to predefine variants for later selection and an Evaluated Variant Set.</p>
<b>Kind</b>	Delivered
<b>Extended by</b>	<a href="#">ECU Extract of VFB System</a> , <a href="#">Overall VFB System</a> , <a href="#">VFB System Extract</a>
<b>Relation Type</b>	<b>Related Element</b>   <b>Mul.</b>   <b>Note</b>



<b>Relation Type</b>	<b>Related Element</b>	<b>Mul.</b>	<b>Note</b>
Aggregates	Consistency Needs	1	Correlation between a group of RunnableEntitys and a group of DataPrototypes.
Aggregates	VFB Top Level System Composition	1	
Aggregates	Complex Driver Component	0..*	
Aggregates	E2E Protection Set	0..*	
Aggregates	ECU Abstraction Software Component	0..*	
Aggregates	Evaluated Variant Set	0..*	
Aggregates	Postbuild Variant Set	0..*	
Aggregates	Predefined Variant	0..*	
Aggregates	System Constant Value Set	0..*	
Aggregates	VFB Atomic Application Software Component	0..*	
Aggregates	VFB Data Type Mapping Set	0..*	
Aggregates	VFB Interfaces	0..*	
Aggregates	VFB Modes	0..*	
Aggregates	VFB Non AUTOSAR Component	0..*	
Aggregates	VFB Parameter Component	0..*	
Aggregates	VFB Sensor Actuator Component	0..*	
Aggregates	VFB Software Component Mapping Constraints	0..*	
Aggregates	VFB Types	0..*	
Produced by	Extend Composition	1	extended system:

<i>Relation Type</i>	<i>Related Element</i>	<i>Mul.</i>	<i>Note</i>
Consumed by	<a href="#">Define Partial Flat Map</a>	1	<p>Various parts of a given VFB system will be used as input:</p> <ul style="list-style-type: none"> <li>• Refer to parameters and variables in port interfaces and their data types.</li> <li>• In order to define unique names, also other the component definitions not in the scope of the partial flat map might be checked.</li> <li>• Set a link to the context of the Flat Map, e.g. a VFB Composition.</li> </ul>
Consumed by	<a href="#">Extend Composition</a>	1	initial system:
Consumed by	<a href="#">Extract the ECU Communication</a>	1	Need as input in order to set up the Data Mapping.
Consumed by	<a href="#">Generate E2E Protection Wrapper</a>	1	Use all elements (like VFB types) that are referred by E2E Protection Set Meth.bindingTime = SystemDesignTime
Consumed by	<a href="#">Generate or Adjust System Flat Map</a>	1	

**Table 3.58: VFB System**

### 3.2.2.2 Overall VFB System

<i>Deliverable</i>	<b>Overall VFB System</b>		
<b>Package</b>	AUTOSAR Root::M2::Methodology::Methodology Library::VFB::Work Products		
<b>Brief Description</b>			
<b>Description</b>	Deliverable containing an overall VFB description. It must contain the VFB Top Level System Composition of the complete system.		
<b>Kind</b>	Delivered		
<b>Extends</b>	<a href="#">VFB System</a>		
<i>Relation Type</i>	<i>Related Element</i>	<i>Mul.</i>	<i>Note</i>
Aggregated by	<a href="#">Abstract System Description</a>	1	
Aggregated by	<a href="#">System Configuration Description</a>	1	
Aggregated by	<a href="#">System Constraint Description</a>	0..1	
Aggregates	<a href="#">System View Mapping</a>	0..1	The Overall VFB System aggregates a potential mapping to the abstract or functional view of the system.
Aggregates	<a href="#">VFB Composition Component</a>	0..*	Further compositions below the top level composition.

<i>Relation Type</i>	<i>Related Element</i>	<i>Mul.</i>	<i>Note</i>
Produced by	<a href="#">Develop a VFB System Description</a>	1	
Consumed by	<a href="#">Develop Application Software</a>	1	The application software needs to refer to the relevant elements of the overall VFB system such as Software Component Types, Port Interfaces and Data Types.
Consumed by	<a href="#">Develop System</a>	0..1	Usually the System refers to elements of an overall VFB descriptions. But for the description of a legacy system, this input might be empty.
Consumed by	<a href="#">Flatten Software Composition</a>	0..1	Read relevant elements starting from VFB Top Level System Composition in case transformation starts with the full system.
Consumed by	<a href="#">Generate or Adjust ECU Flat Map</a>	0..1	Used to set the upstream references in case one starts from a complete system.

**Table 3.59: Overall VFB System**

### 3.2.2.3 VFB System Extract

<i>Deliverable</i>	<b>VFB System Extract</b>		
<i>Package</i>	AUTOSAR Root::M2::Methodology::Methodology Library::VFB::Work Products		
<i>Brief Description</i>	The VFB description for the partial system.		
<i>Description</i>	The VFB description for a sub-system. It contains only those software components which belong to this sub-system. It should contain a VFB Top Level System Composition which has unconnected ports reflecting the connection points to the outer system.		
<i>Kind</i>	Delivered		
<i>Extends</i>	<a href="#">VFB System</a>		
<i>Relation Type</i>	<i>Related Element</i>	<i>Mul.</i>	<i>Note</i>
Aggregated by	<a href="#">System Extract</a>	1	
Aggregates	<a href="#">System View Mapping</a>	0..1	The VFB System Extract aggregates a potential mapping to the abstract or functional view of the system.
Aggregates	<a href="#">VFB Composition Component</a>	0..*	Further compositions below the top level composition.
Consumed by	<a href="#">Flatten Software Composition</a>	0..1	Read relevant elements starting from VFB Top Level System Composition in case transformation starts from the system extract.
Consumed by	<a href="#">Generate or Adjust ECU Flat Map</a>	0..1	Used to set the upstream references in case one starts from a system extract.

**Table 3.60: VFB System Extract**

### 3.2.2.4 VFB Top Level System Composition

<b>Artifact</b>	<b>VFB Top Level System Composition</b>		
<b>Package</b>	AUTOSAR Root::M2::Methodology::Methodology Library::VFB::Work Products		
<b>Brief Description</b>	Highest Level Composition consisting of all components that make up the Virtual Functional Bus.		
<b>Description</b>	<p>Highest Level Composition consisting of all components and their connectors that make up the VFB System Deliverable.</p> <p>This composition is not allowed to have ports if it represents the top level composition of an Overall VFB System, but it may have unconnected ports (and port groups) if it is at the top of a System Extract or ECU Extract.</p>		
<b>Kind</b>	AUTOSAR XML		
<b>Relation Type</b>	<b>Related Element</b>	<b>Mul.</b>	<b>Note</b>
Aggregated by	<a href="#">VFB System</a>	1	
Produced by	<a href="#">Define VFB Top Level</a>	1	
Consumed by	<a href="#">Assign Top Level Composition</a>	1	
Consumed by	<a href="#">Define E2E Protection Set for Swc</a>	1	
Consumed by	<a href="#">Define Software Component Mapping Constraints</a>	1	
Consumed by	<a href="#">Define VFB Component Constraints</a>	1	
Consumed by	<a href="#">Define VFB Variants</a>	1	
Consumed by	<a href="#">Deploy Software Component</a>	1	
Use meta model element	CompositionSw ComponentType	1	

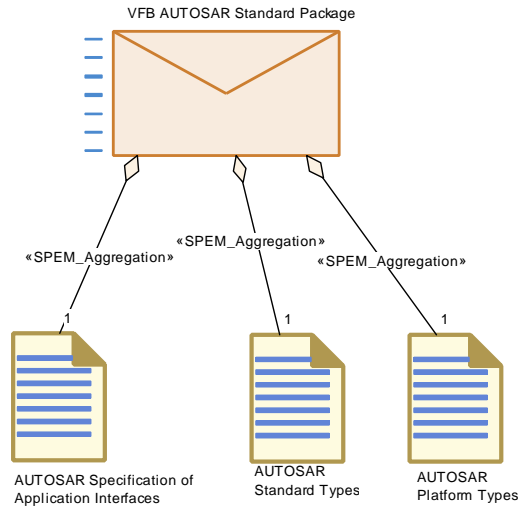
**Table 3.61: VFB Top Level System Composition**

### 3.2.2.5 VFB Composition Component

<b>Artifact</b>	<b>VFB Composition Component</b>		
<b>Package</b>	AUTOSAR Root::M2::Methodology::Methodology Library::VFB::Work Products		
<b>Brief Description</b>	Describes a set of VFB CompositionTypes.		
<b>Description</b>	Describes a set of CompositionComponentTypes, which may be nested. A VFB composition aggregates component types to encapsulate and abstract subsystem functionality. Compositions contain instances of components (other compositions and atomic components), as well as the connectors between them.		
<b>Kind</b>	AUTOSAR XML		
<b>Relation Type</b>	<b>Related Element</b>	<b>Mul.</b>	<b>Note</b>
Aggregated by	<a href="#">Delivered Atomic Software Components</a>	0..*	In case the delivered atomic components make up one or more VFB Compositions, the composition description(s) shall be included in the delivery.
Aggregated by	<a href="#">Overall VFB System</a>	0..*	Further compositions below the top level composition.
Aggregated by	<a href="#">VFB System Extract</a>	0..*	Further compositions below the top level composition.
Produced by	<a href="#">Define VFB Composition Component</a>	1	
Produced by	<a href="#">Extend Composition</a>	0..*	
Consumed by	<a href="#">Set System Root</a>	1	Only the reference to the artifact is needed
Consumed by	<a href="#">Define VFB Component Constraints</a>	1..*	
Consumed by	<a href="#">Define VFB Timing</a>	1..*	
Consumed by	<a href="#">Define VFB Variants</a>	1..*	
Consumed by	<a href="#">Define E2E Protection Set for Swc</a>	0..*	
Consumed by	<a href="#">Define VFB Composition Component</a>	0..*	
Consumed by	<a href="#">Define VFB Top Level</a>	0..*	
Use meta model element	CompositionSw ComponentType	1	
Use meta model element	SwComponent Type	1	

**Table 3.62: VFB Composition Component**

### 3.2.2.6 VFB AUTOSAR Standard Package



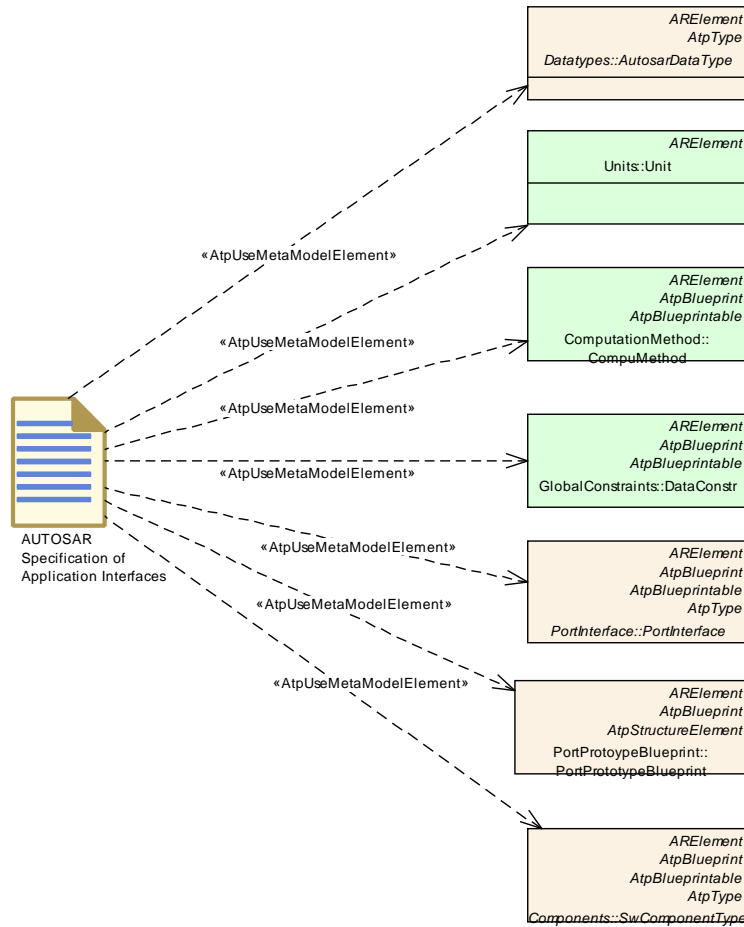
**Figure 3.31: Structure of Deliverable VFB AUTOSAR Standard Package**

<b>Deliverable</b>	<b>VFB AUTOSAR Standard Package</b>		
<b>Package</b>	AUTOSAR Root::M2::Methodology::Methodology Library::VFB::Work Products		
<b>Brief Description</b>	Package with standardized AUTOSAR DataTypes, PortInterfaces, ComponentTypes (may include compositions), etc. on VFB level.		
<b>Description</b>	<p>Package with standardized AUTOSAR elements needed on VFB level.</p> <p>This deliverable is released by AUTOSAR and is readonly within the methodology.</p>		
<b>Kind</b>	Delivered		
<b>Relation Type</b>	<b>Related Element</b>	<b>Mul.</b>	<b>Note</b>
Aggregates	<a href="#">AUTOSAR Platform Types</a>	1	
Aggregates	<a href="#">AUTOSAR Specification of Application Interfaces</a>	1	
Aggregates	<a href="#">AUTOSAR Standard Types</a>	1	
Consumed by	<a href="#">Define ECU Abstraction Component</a>	1	Use port blueprints in order to create ports with standardized application interfaces.
Consumed by	<a href="#">Develop a VFB System Description</a>	1..*	
Consumed by	<a href="#">Develop an Abstract System Description</a>	1..*	
Consumed by	<a href="#">Define Atomic Software Component Internal Behavior</a>	0..1	Use standardized elements (e.g. Data Types) as blueprints (as far as applicable) to create the corresponding elements of the actual project.

<b>Relation Type</b>	<b>Related Element</b>	<b>Mul.</b>	<b>Note</b>
Consumed by	Define Complex Driver Component	0..1	Use port blueprints in order to create ports with standardized application interfaces.
Consumed by	Define VFB Application Software Component	0..1	Use port blueprints in order to create ports with standardized application interfaces.
Consumed by	Define VFB Composition Component	0..1	Use port blueprints in order to create ports with standardized application interfaces.
Consumed by	Define VFB Interfaces	0..1	Use standardized Port Interfaces as blueprints (as far as applicable) to create the corresponding elements of the actual project.
Consumed by	Define VFB Parameter Component	0..1	Use port blueprints in order to create ports with standardized application interfaces.
Consumed by	Define VFB Sensor or Actuator Component	0..1	Use port blueprints in order to create ports with standardized application interfaces.
Consumed by	Define VFB Timing	0..1	
Consumed by	Define VFB Types	0..1	Use standardized elements (e.g. Data Types, Compu Methods) as blueprints (as far as applicable) to create the corresponding elements of the actual project.
Consumed by	Define Wrapper Components to Integrate Legacy Software	0..1	Use port blueprints in order to create ports with standardized application interfaces.
Consumed by	Generate Atomic Software Component Contract Header Files	0..1	
Consumed by	Generate Component Header File in Vendor Mode	0..1	
Consumed by	Generate Component Prebuild Data Set	0..1	

**Table 3.63: VFB AUTOSAR Standard Package**

**3.2.2.7 AUTOSAR Specification of Application Interfaces**



**Figure 3.32: The AUTOSAR Specification of Application Interfaces**

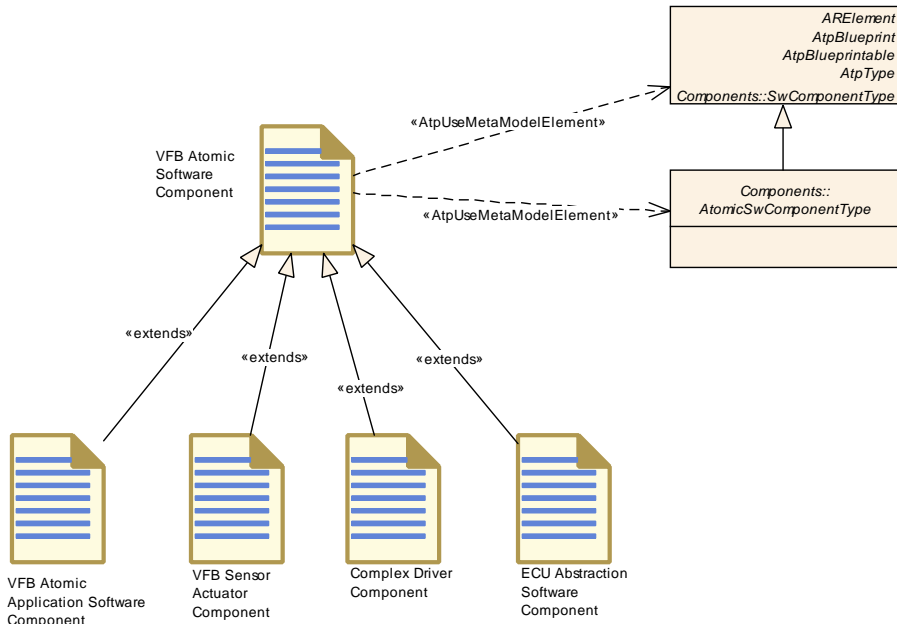
<b>Artifact</b>	<b>AUTOSAR Specification of Application Interfaces</b>		
<b>Package</b>	AUTOSAR Root::M2::Methodology::Methodology Library::VFB::Work Products		
<b>Brief Description</b>	Definitions of the AUTOSAR standard application interfaces.		
<b>Description</b>	<p>This includes standardized data types, port interfaces, units, port blueprints and example component types (including compositions) for the design of Application Software Components.</p> <p>Note that most of the content is not meant as direct input for defining a VFB system but as so-called blueprints:</p> <p>Blueprints need to be completed with company or project specific elements (e.g. a component type defined as blueprint may need additional ports or a data type defined as blueprint may need additional properties).</p>		
<b>Kind</b>	AUTOSAR XML		
<b>Relation Type</b>	<b>Related Element</b>	<b>Mul.</b>	<b>Note</b>
Aggregated by	VFB AUTOSAR Standard Package	1	



<i>Relation Type</i>	<i>Related Element</i>	<i>Mul.</i>	<i>Note</i>
Use meta model element	AutosarDataType	1	
Use meta model element	CompuMethod	1	
Use meta model element	DataConstr	1	
Use meta model element	PortInterface	1	
Use meta model element	PortPrototype Blueprint	1	
Use meta model element	SwComponent Type	1	
Use meta model element	Unit	1	

**Table 3.64: AUTOSAR Specification of Application Interfaces**

**3.2.2.8 VFB Atomic Software Component**



**Figure 3.33: The Generic Work Product VFB Atomic Software Component**

<b>Artifact</b>	<b>VFB Atomic Software Component</b>		
<b>Package</b>	AUTOSAR Root::M2::Methodology::Methodology Library::VFB::Work Products		
<b>Brief Description</b>	Description of an Atomic VFB Component.		
<b>Description</b>	The description of an Atomic Software Component Type without Internal Behavior. Note that there are more specific artifacts extending this one. This artifact is used to describe general use cases which are valid for all kind of Atomic Software Components.		
<b>Kind</b>	AUTOSAR XML		
<b>Extended by</b>	Complex Driver Component, ECU Abstraction Software Component, VFB Atomic Application Software Component, VFB Sensor Actuator Component		
<b>Relation Type</b>	<b>Related Element</b>	<b>Mul.</b>	<b>Note</b>
Aggregated by	Delivered Atomic Software Components	1..*	
Produced by	Define Symbol Props for Types	0..*	symbolProps: The symbolProps attribute redefines the software component type name used in the code of the RTE. This resolves name clashes among different software component types designed accidentally with the same shortName.  Note that this output is a splittable element, so it can be added later without changing the VFB model.
Produced by	Extend Composition	0..*	
Consumed by	Define VFB Component Constraints	2..*	
Consumed by	Define Atomic Software Component Internal Behavior	1	
Consumed by	Generate Atomic Software Component Contract Header Files	1	Meth.bindingTime = SystemDesignTime
Consumed by	Generate Component Header File in Vendor Mode	1	Meth.bindingTime = SystemDesignTime
Consumed by	Generate Component Prebuild Data Set	1	Meth.bindingTime = CodeGenerationTime
Consumed by	Define E2E Protection Set for Swc	1..*	
Consumed by	Select Software Component Implementation	1..*	
Consumed by	Define Consistency Needs	0..*	The description of an AtomicSoftwareComponentType without InternalBehavior.

<i>Relation Type</i>	<i>Related Element</i>	<i>Mul.</i>	<i>Note</i>
Consumed by	<a href="#">Define VFB Composition Component</a>	0..*	
Consumed by	<a href="#">Define VFB Timing</a>	0..*	
Consumed by	<a href="#">Define VFB Top Level</a>	0..*	
Consumed by	<a href="#">Define VFB Variants</a>	0..*	
Use meta model element	AtomicSwComponentType	1	
Use meta model element	SwComponentType	1	

**Table 3.65: VFB Atomic Software Component**

### 3.2.2.9 VFB Atomic Application Software Component

<b>Artifact</b>	<b>VFB Atomic Application Software Component</b>		
<b>Package</b>	AUTOSAR Root::M2::Methodology::Methodology Library::VFB::Work Products		
<b>Brief Description</b>	Description of an Atomic VFB Component.		
<b>Description</b>	The description of an Application Software Component Type.  It is used to represent the ECU-independent application software.		
<b>Kind</b>	AUTOSAR XML		
<b>Extends</b>	<a href="#">VFB Atomic Software Component</a>		
<b>Relation Type</b>	<b>Related Element</b>	<b>Mul.</b>	<b>Note</b>
Aggregated by	<a href="#">VFB System</a>	0..*	
Produced by	<a href="#">Define VFB Application Software Component</a>	1	
Use meta model element	ApplicationSwComponentType	1	

**Table 3.66: VFB Atomic Application Software Component**

### 3.2.2.10 Complex Driver Component

<b>Artifact</b>	<b>Complex Driver Component</b>		
<b>Package</b>	AUTOSAR Root::M2::Methodology::Methodology Library::VFB::Work Products		
<b>Brief Description</b>	VFB Description of a Complex Driver Component.		
<b>Description</b>	<p>The Complex Driver Component is a special VFB Atomic Software Component that has direct access to hardware on an ECU and which is therefore linked to a specific ECU or specific hardware.</p> <p>It uses the meta-model element <code>ComplexDeviceDriverSwComponentType</code> which introduces the possibility to link from the software representation to its hardware description provided by the ECU Resource Template.</p> <p>It provides (non-standardized) AUTOSAR Interfaces via ports on VFB level.</p>		
<b>Kind</b>	AUTOSAR XML		
<b>Extends</b>	<a href="#">VFB Atomic Software Component</a>		
<b>Relation Type</b>	<b>Related Element</b>	<b>Mul.</b>	<b>Note</b>
Aggregated by	<a href="#">VFB System</a>	0..*	
Produced by	<a href="#">Define Complex Driver Component</a>	1	
Consumed by	<a href="#">Configure Debug</a>	0..1	
Consumed by	<a href="#">Map Software Component to BS W</a>	0..1	
Use meta model element	<code>ComplexDeviceDriverSwComponentType</code>	1	

**Table 3.67: Complex Driver Component**

### 3.2.2.11 ECU Abstraction Software Component

<b>Artifact</b>	<b>ECU Abstraction Software Component</b>		
<b>Package</b>	AUTOSAR Root::M2::Methodology::Methodology Library::VFB::Work Products		
<b>Brief Description</b>	VFB Description of an ECU Abstraction Software Component.		
<b>Description</b>	<p>The ECU Abstraction Software Component is a special Atomic Software Component that sits between a component that wants to access ECU periphery (typically a Sensor Actuator Component) and the Microcontroller Abstraction.</p> <p>It provides (non-standardized) AUTOSAR Interfaces via ports which represent the ECU periphery. The EcuAbstractionSwComponentType introduces the possibility to link from the software representation to its hardware description provided by the ECU Resource Template.</p> <p>During integration, an ECU Abstraction Software Component will be mapped to a BSW module which implements it and which will directly (without RTE) be connected to the Microcontroller Abstraction.</p>		
<b>Kind</b>	AUTOSAR XML		
<b>Extends</b>	<a href="#">VFB Atomic Software Component</a>		
<b>Relation Type</b>	<b>Related Element</b>	<b>Mul.</b>	<b>Note</b>
Aggregated by	<a href="#">VFB System</a>	0..*	
Produced by	<a href="#">Define ECU Abstraction Component</a>	1	
Consumed by	<a href="#">Map Software Component to BSW</a>	0..1	
Use meta model element	EcuAbstractionSwComponentType	1	

**Table 3.68: ECU Abstraction Software Component**

### 3.2.2.12 VFB Parameter Component

<b>Artifact</b>	<b>VFB Parameter Component</b>		
<b>Package</b>	AUTOSAR Root::M2::Methodology::Methodology Library::VFB::Work Products		
<b>Brief Description</b>	A ParameterComponentType defines parameters and characteristic values accessible via provided Ports.		
<b>Description</b>	A ParameterSwComponentType defines parameters and characteristic values accessible via Provide Ports. The provided values are the same for all connected Component Prototypes. This is as opposed to private parameters which are only available within the scope of an Atomic Software Component		
<b>Kind</b>	AUTOSAR XML		
<b>Relation Type</b>	<b>Related Element</b>	<b>Mul.</b>	<b>Note</b>
Aggregated by	<a href="#">VFB System</a>	0..*	
Produced by	<a href="#">Define VFB Parameter Component</a>	1	

<i>Relation Type</i>	<i>Related Element</i>	<i>Mul.</i>	<i>Note</i>
Produced by	<a href="#">Extend Composition</a>	0..*	
Consumed by	<a href="#">Define VFB Composition Component</a>	0..*	
Consumed by	<a href="#">Define VFB Timing</a>	0..*	
Consumed by	<a href="#">Define VFB Top Level</a>	0..*	
Consumed by	<a href="#">Define VFB Variants</a>	0..*	
Use meta model element	ParameterSw ComponentType	1	

**Table 3.69: VFB Parameter Component**

### 3.2.2.13 VFB Sensor Actuator Component

<i>Artifact</i>	<b>VFB Sensor Actuator Component</b>		
<i>Package</i>	AUTOSAR Root::M2::Methodology::Methodology Library::VFB::Work Products		
<i>Brief Description</i>	Describes a sensor or actuator component that exist at the VFB Level and represents the physical interface of an actual sensor or actuator hardware element.		
<i>Description</i>	<p>A Sensor Actuator Software Component is an Atomic Software Component that makes the functionality of a sensor or actuator usable for other software components. That means that the Sensor Actuator Software Component provides to the application software components an interface for the physical values of the sensors and actuators. It is written for a concrete sensor or actuator and uses the ECU Abstraction interface.</p> <p>It references the description of the associated hardware elements.</p>		
<i>Kind</i>	AUTOSAR XML		
<i>Extends</i>	<a href="#">VFB Atomic Software Component</a>		
<i>Relation Type</i>	<i>Related Element</i>	<i>Mul.</i>	<i>Note</i>
Aggregated by	<a href="#">Complete ECU Description</a>	0..*	
Aggregated by	<a href="#">VFB System</a>	0..*	
Produced by	<a href="#">Define VFB Sensor or Actuator Component</a>	1	
Use meta model element	SensorActuatorSw ComponentType	1	

**Table 3.70: VFB Sensor Actuator Component**

### 3.2.2.14 VFB Non AUTOSAR Component

<b>Artifact</b>	<b>VFB Non AUTOSAR Component</b>		
<b>Package</b>	AUTOSAR Root::M2::Methodology::Methodology Library::VFB::Work Products		
<b>Brief Description</b>	A Component used to describe the non-autosar entities that exist at the VFB level.		
<b>Description</b>	A Component used to describe the non-AUTOSAR entities that exist at the VFB level.		
<b>Kind</b>	AUTOSAR XML		
<b>Relation Type</b>	<b>Related Element</b>	<b>Mul.</b>	<b>Note</b>
Aggregated by	<a href="#">VFB System</a>	0..*	
Produced by	<a href="#">Define Wrapper Components to Integrate Legacy Software</a>	1	
Produced by	<a href="#">Extend Composition</a>	0..*	
Consumed by	<a href="#">Define VFB Composition Component</a>	0..*	
Consumed by	<a href="#">Define VFB Timing</a>	0..*	
Consumed by	<a href="#">Define VFB Top Level</a>	0..*	
Consumed by	<a href="#">Define VFB Variants</a>	0..*	
Use meta model element	SwComponent Type	1	

**Table 3.71: VFB Non AUTOSAR Component**

### 3.2.2.15 VFB Interfaces

<b>Artifact</b>	<b>VFB Interfaces</b>		
<b>Package</b>	AUTOSAR Root::M2::Methodology::Methodology Library::VFB::Work Products		
<b>Brief Description</b>	Interfaces and related elements that form part of the VFB, but are not standardized by AUTOSAR.		
<b>Description</b>	Interfaces and related elements that form part of the VFB, but are not standardized by AUTOSAR.		
<b>Kind</b>	AUTOSAR XML		
<b>Relation Type</b>	<b>Related Element</b>	<b>Mul.</b>	<b>Note</b>
Aggregated by	<a href="#">Delivered Atomic Software Components</a>	0..*	
Aggregated by	<a href="#">VFB System</a>	0..*	
Produced by	<a href="#">Define VFB Interfaces</a>	1..*	
Produced by	<a href="#">Extend Composition</a>	0..*	

<b>Relation Type</b>	<b>Related Element</b>	<b>Mul.</b>	<b>Note</b>
Consumed by	Define ECU Abstraction Component	1	
Consumed by	Define Complex Driver Component	1..*	
Consumed by	Define E2E Protection Set for Swc	1..*	
Consumed by	Define VFB Application Software Component	1..*	
Consumed by	Define VFB Composition Component	1..*	
Consumed by	Define VFB Parameter Component	1..*	
Consumed by	Define VFB Sensor or Actuator Component	1..*	
Consumed by	Define VFB Timing	1..*	
Consumed by	Define VFB Top Level	1..*	
Consumed by	Define Consistency Needs	0..*	Interfaces which are relevant for the consistency definition.
Consumed by	Define VFB Variants	0..*	
Consumed by	Define Wrapper Components to Integrate Legacy Software	0..*	
Consumed by	Generate Atomic Software Component Contract Header Files	0..*	Meth.bindingTime = SystemDesignTime
Consumed by	Generate Component Header File in Vendor Mode	0..*	Meth.bindingTime = SystemDesignTime
Consumed by	Generate Component Prebuild Data Set	0..*	Meth.bindingTime = CodeGenerationTime
Use meta model element	AutosarDataType	1	
Use meta model element	ModeDeclaration Group	1	
Use meta model element	PortInterface	1	

**Table 3.72: VFB Interfaces**

### 3.2.2.16 VFB Types



<b>Artifact</b>	<b>VFB Types</b>		
<b>Package</b>	AUTOSAR Root::M2::Methodology::Methodology Library::VFB::Work Products		
<b>Brief Description</b>	Data types and related elements that form part of the VFB, but are not standardized by AUTOSAR.		
<b>Description</b>	<p>Description of AutosarDataTypes and related elements (e.g. units, computation methods, etc.) that form part of the VFB, but are not standardized by AUTOSAR. This may also include copies of standardized elements which have been completed with project specific information (e.g. with calibration access information or computation methods). A VFB system can contain several different instances of this artifact, which may fulfill different roles.</p> <p>AutosarDataTypes can come as so-called ApplicationDatatypes or ImplementationDataTypes. This package can contain both kinds but they can also be split into separate artifacts. However, since it is also possible to generate ImplementationDataTypes from ApplicationDataTypes, a VFB system can be completely defined with ApplicationDatatypes only.</p> <p>Note that this work product is meant for use cases, in which a set of data types is maintained as a separate artifact. It is also possible to define particular AutosarDataTypes as part of another artifact, e.g. of VFB Interfaces if the types are closely related to certain port interfaces.</p> <p>In the methodology this artifact stands not only for data type definitions, but also for related elements like addressing methods, units, computation methods, constraints. etc. This is done for simplicity, because these elements are often consumed by the same tasks. Of course these can be treated as separate artifacts in real projects.</p>		
<b>Kind</b>	AUTOSAR XML		
<b>Relation Type</b>	<b>Related Element</b>	<b>Mul.</b>	<b>Note</b>
Aggregated by	<a href="#">Delivered Atomic Software Components</a>	0..*	
Aggregated by	<a href="#">VFB System</a>	0..*	
Produced by	<a href="#">Define VFB Types</a>	1..*	
Produced by	<a href="#">Define Symbol Props for Types</a>	0..*	<p>symbolProps: The symbolProps attribute redefines the implementation data type name used in the code of the RTE and/or the component. This resolves name clashes among different implementation data types designed accidentally with the same shortName.</p> <p>Note that this output is a splittable element, so it can be added later without changing the VFB model.</p>
Produced by	<a href="#">Extend Composition</a>	0..*	
Consumed by	<a href="#">Define ECU Abstraction Component</a>	1	

<b>Relation Type</b>	<b>Related Element</b>	<b>Mul.</b>	<b>Note</b>
Consumed by	Define Complex Driver Component	1..*	
Consumed by	Define E2E Protection Set for Swc	1..*	
Consumed by	Define VFB Application Software Component	1..*	
Consumed by	Define VFB Composition Component	1..*	
Consumed by	Define VFB Interfaces	1..*	
Consumed by	Define VFB Parameter Component	1..*	
Consumed by	Define VFB Sensor or Actuator Component	1..*	
Consumed by	Define VFB Top Level	1..*	
Consumed by	Generate BSW Memory Mapping Header	1..*	SwAddrMethod: Referred SwAddrMethods Meth.bindingTime = SystemDesignTime
Consumed by	Generate Compiler Configuration	1..*	SwAddrMethod: Referred SwAddrMethods. They provide the default names for the compiler memory classes. Meth.bindingTime = SystemDesignTime
Consumed by	Generate SWC Memory Mapping Header	1..*	SwAddrMethod: Referred SwAddrMethods Meth.bindingTime = SystemDesignTime
Consumed by	Configure Memmap Allocation	0..*	SwAddrMethods: SwAddrMethods used for the generic mapping. Note that one SwAddrmethod can represent several memory sections.
Consumed by	Define Consistency Needs	0..*	Data types which are relevant for the consistency definition.
Consumed by	Define VFB Constants	0..*	
Consumed by	Define Wrapper Components to Integrate Legacy Software	0..*	
Consumed by	Generate Atomic Software Component Contract Header Files	0..*	Meth.bindingTime = SystemDesignTime
Consumed by	Generate Component Header File in Vendor Mode	0..*	Meth.bindingTime = SystemDesignTime

<i>Relation Type</i>	<i>Related Element</i>	<i>Mul.</i>	<i>Note</i>
Consumed by	<a href="#">Generate Component Prebuild Data Set</a>	0..*	Meth.bindingTime = CodeGenerationTime
Use meta model element	ApplicationData Type	1	
Use meta model element	AutosarDataType	1	
Use meta model element	CompuMethod	1	
Use meta model element	DataConstr	1	
Use meta model element	Implementation DataType	1	
Use meta model element	SwAddrMethod	1	
Use meta model element	Unit	1	

**Table 3.73: VFB Types**

### 3.2.2.17 VFB Data Type Mapping Set

<i>Artifact</i>	<i>VFB Data Type Mapping Set</i>		
<b>Package</b>	AUTOSAR Root::M2::Methodology::Methodology Library::VFB::Work Products		
<b>Brief Description</b>	Mapping Set between Application and Implementation Data Types.		
<b>Description</b>	Mapping Set between Application and Implementation Data Types.		
<b>Kind</b>	AUTOSAR XML		
<i>Relation Type</i>	<i>Related Element</i>	<i>Mul.</i>	<i>Note</i>
Aggregated by	<a href="#">Delivered Atomic Software Components</a>	0..*	
Aggregated by	<a href="#">VFB System</a>	0..*	
Produced by	<a href="#">Define VFB Types</a>	0..*	
Consumed by	<a href="#">Generate Atomic Software Component Contract Header Files</a>	0..1	Meth.bindingTime = SystemDesignTime
Consumed by	<a href="#">Generate Component Header File in Vendor Mode</a>	0..1	Meth.bindingTime = SystemDesignTime
Consumed by	<a href="#">Generate Component Prebuild Data Set</a>	0..1	Meth.bindingTime = CodeGenerationTime
Consumed by	<a href="#">Define VFB Constants</a>	0..*	
Use meta model element	DataTypeMapping Set	1	

**Table 3.74: VFB Data Type Mapping Set**

### 3.2.2.18 VFB Modes

<b>Artifact</b>	<b>VFB Modes</b>		
<b>Package</b>	AUTOSAR Root::M2::Methodology::Methodology Library::VFB::Work Products		
<b>Brief Description</b>	Modes declared here are non-AUTOSAR standard. They are modes that are managed by a software component acting as a application mode manager.		
<b>Description</b>	Desclaration of mode groups and of the modes they contain. Modes declared here are non-AUTOSAR standard. They are modes that are managed by an application software component acting as a mode manager.		
<b>Kind</b>	AUTOSAR XML		
<b>Relation Type</b>	<b>Related Element</b>	<b>Mul.</b>	<b>Note</b>
Aggregated by	<a href="#">Delivered Atomic Software Components</a>	0..*	
Aggregated by	<a href="#">VFB System</a>	0..*	
Produced by	<a href="#">Define VFB Modes</a>	1..*	
Produced by	<a href="#">Extend Composition</a>	0..*	
Consumed by	<a href="#">Define Complex Driver Component</a>	0..*	
Consumed by	<a href="#">Define ECU Abstraction Component</a>	0..*	
Consumed by	<a href="#">Define VFB Application Software Component</a>	0..*	
Consumed by	<a href="#">Define VFB Composition Component</a>	0..*	
Consumed by	<a href="#">Define VFB Top Level</a>	0..*	
Consumed by	<a href="#">Define Wrapper Components to Integrate Legacy Software</a>	0..*	
Consumed by	<a href="#">Generate Atomic Software Component Contract Header Files</a>	0..*	Meth.bindingTime = SystemDesignTime
Consumed by	<a href="#">Generate Component Header File in Vendor Mode</a>	0..*	Meth.bindingTime = SystemDesignTime
Consumed by	<a href="#">Generate Component Prebuild Data Set</a>	0..*	Meth.bindingTime = CodeGenerationTime
Use meta model element	ModeDeclaration Group	1	

**Table 3.75: VFB Modes**

### 3.2.2.19 VFB Constants

<b>Artifact</b>	<b>VFB Constants</b>		
<b>Package</b>	AUTOSAR Root::M2::Methodology::Methodology Library::VFB::Work Products		
<b>Brief Description</b>	Specification of constant data for usage as initial values by other artifacts.		
<b>Description</b>	<p>Specification of constant data for usage as initial values by other artifacts, e.g. initial values for calibration parameters or variable data elements provided in ports.</p> <p>By using the ConstantSpecification meta-class, such data can be standalone artifacts and thus be maintained independently of the components or interfaces to which they apply.</p>		
<b>Kind</b>	AUTOSAR XML		
<b>Relation Type</b>	<b>Related Element</b>	<b>Mul.</b>	<b>Note</b>
Produced by	<a href="#">Define VFB Constants</a>	1..*	
Use meta model element	ConstantSpecification	1	

**Table 3.76: VFB Constants**

### 3.2.2.20 VFB Software Component Mapping Constraints

<b>Artifact</b>	<b>VFB Software Component Mapping Constraints</b>		
<b>Package</b>	AUTOSAR Root::M2::Methodology::Methodology Library::VFB::Work Products		
<b>Brief Description</b>	A defined constraint on how certain components must be mapped (clustered or separated) to ECUs.		
<b>Description</b>	<p>One or more defined constraints on how certain components must be mapped (clustered, separated or dedicated mapping).</p> <p>This defines constraints to which components need to be mapped to a single ECU, and which must be mapped to separate ECUs, without regard to any particular ECU or topology.</p> <p>Notes: The meta-model element SystemMapping allows to describe a collection of such constraints as one single artifact.</p>		
<b>Kind</b>	AUTOSAR XML		
<b>Relation Type</b>	<b>Related Element</b>	<b>Mul.</b>	<b>Note</b>
Aggregated by	<a href="#">VFB System</a>	0..*	
Produced by	<a href="#">Define VFB Component Constraints</a>	1..*	
Produced by	<a href="#">Extend Composition</a>	0..*	
Consumed by	<a href="#">Deploy Software Component</a>	0..1	Constraints defined on the VFB level
Use meta model element	MappingConstraint	1	

<i>Relation Type</i>	<i>Related Element</i>	<i>Mul.</i>	<i>Note</i>
Use meta model element	SystemMapping	1	The splittable element SystemMapping is the root for this artifact.

**Table 3.77: VFB Software Component Mapping Constraints**

### 3.2.2.21 VFB Timing

<i>Artifact</i>	<b>VFB Timing</b>		
<i>Package</i>	AUTOSAR Root::M2::Methodology::Methodology Library::VFB::Work Products		
<i>Brief Description</i>	Atomic Software Component or Composition Component TimingDescription and TimingConstraints		
<i>Description</i>	TimingDescription and TimingConstraints defined for an Atomic Software Component or a Composition Component		
<i>Kind</i>	AUTOSAR XML		
<i>Relation Type</i>	<i>Related Element</i>	<i>Mul.</i>	<i>Note</i>
Produced by	<a href="#">Define VFB Timing</a>	1	
Consumed by	<a href="#">Define Software Component Timing</a>	0..1	
Consumed by	<a href="#">Define System Timing</a>	0..1	
Consumed by	<a href="#">Define VFB Variants</a>	0..1	
Use meta model element	VfbTiming	1	

**Table 3.78: VFB Timing**

### 3.2.2.22 E2E Protection Set

<i>Artifact</i>	<b>E2E Protection Set</b>		
<i>Package</i>	AUTOSAR Root::M2::Methodology::Methodology Library::VFB::Work Products		
<i>Brief Description</i>			
<i>Description</i>	E2E Protection Set : description of all the configuration used to protect a specific communication.		
<i>Kind</i>	AUTOSAR XML		
<i>Relation Type</i>	<i>Related Element</i>	<i>Mul.</i>	<i>Note</i>
Aggregated by	<a href="#">Delivered Atomic Software Components</a>	0..1	
Aggregated by	<a href="#">VFB System</a>	0..*	
Produced by	<a href="#">Define E2E Protection Set for Swc</a>	1	
Consumed by	<a href="#">Generate E2E Protection Wrapper</a>	1	Meth.bindingTime = SystemDesignTime
Consumed by	<a href="#">Define VFB Top Level</a>	0..1	

<i>Relation Type</i>	<i>Related Element</i>	<i>Mul.</i>	<i>Note</i>
Use meta model element	EndToEndProtectionSet	1	

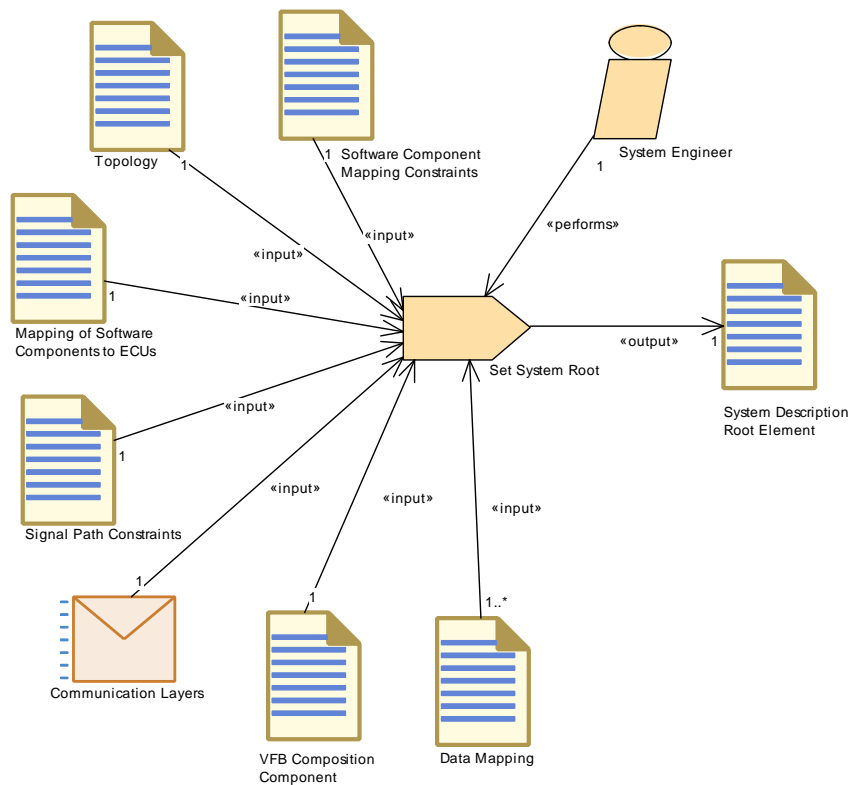
**Table 3.79: E2E Protection Set**

### 3.3 System

This chapter contains the definition of work products and tasks used for the development of systems and sub-systems. For the definition of the relevant meta-model elements refer to [6] and [14].

#### 3.3.1 Tasks

##### 3.3.1.1 Set System Root



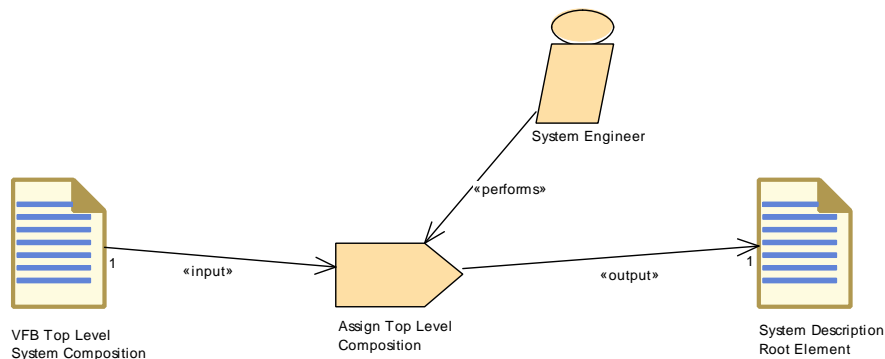
**Figure 3.34: Set System Root**

<b>Task Definition</b>	<b>Set System Root</b>		
<b>Package</b>	AUTOSAR Root::M2::Methodology::Methodology Library::System::Tasks		
<b>Brief Description</b>			
<b>Description</b>	Set up the root element of a system description.		
<b>Relation Type</b>	<b>Related Element</b>	<b>Mul.</b>	<b>Note</b>

Relation Type	Related Element	Mul.	Note
Performed by	System Engineer	1	
Consumes	Communication Layers	1	Only the reference to the artifact is needed
Consumes	Mapping of Software Components to ECUs	1	Only the reference to the artifact is needed
Consumes	Signal Path Constraints	1	Only the reference to the artifact is needed
Consumes	Software Component Mapping Constraints	1	Only the reference to the artifact is needed
Consumes	Topology	1	Only the reference to the artifact is needed
Consumes	VFB Composition Component	1	Only the reference to the artifact is needed
Consumes	Data Mapping	1..*	Only the reference to the artifact is needed
Produces	System Description Root Element	1	Set up the root element, and the links to other artifacts

**Table 3.80: Set System Root**

### 3.3.1.2 Assign Top Level Composition



**Figure 3.35: Assign Top Level Composition**

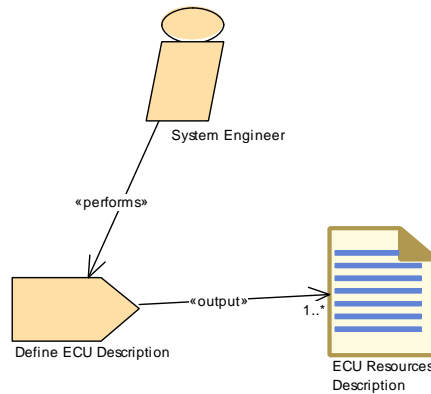
Task Definition	Assign Top Level Composition		
Package	AUTOSAR Root::M2::Methodology::Methodology Library::System::Tasks		
Brief Description			
Description	Assign a VFB Top Level Composition to the System Root		
Relation Type	Related Element	Mul.	Note
Performed by	System Engineer	1	
Consumes	VFB Top Level System Composition	1	



Relation Type	Related Element	Mul.	Note
Produces	System Description Root Element	1	

**Table 3.81: Assign Top Level Composition**

**3.3.1.3 Define ECU Description**

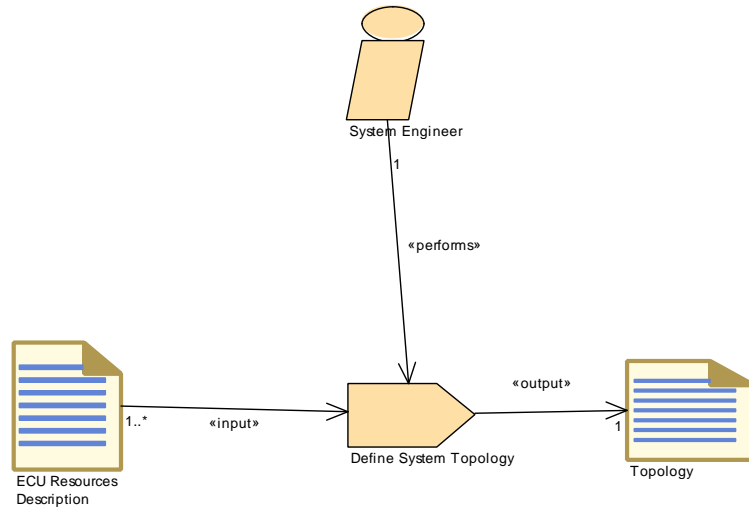


**Figure 3.36: Define ECU description**

Task Definition	Define ECU Description		
Package	AUTOSAR Root::M2::Methodology::Methodology Library::System::Tasks		
Brief Description	Define a particular ECU's resources.		
Description	Define a particular ECU's resources by describing Hardware Elements, pins, connections. The HW Elements are the main describing elements of an ECU, e.g. processing units, memory, peripherals, sensors and actuators. HW Elements have a unique name and can be identified within the ECU description. HW Elements do not necessarily have to be described on the level of an ECU. It is possible to describe HW Elements as parts of other HW Elements. By this means, a hierarchical description of HW Elements can be created. HW Elements provide HW PinGroups and HW Pins for being interconnected among each others. HW PinGroups allow a rough description of how certain groups of HW Pins are arranged. The detailed description can be done using the HW Pins. HW Connections are used to describe connection on several levels: connections between HW Elements, connections between HW PinGroups, connections between HW Pins.		
Relation Type	Related Element	Mul.	Note
Performed by	System Engineer	1	
Produces	ECU Resources Description	1..*	

**Table 3.82: Define ECU Description**

### 3.3.1.4 Define System Topology

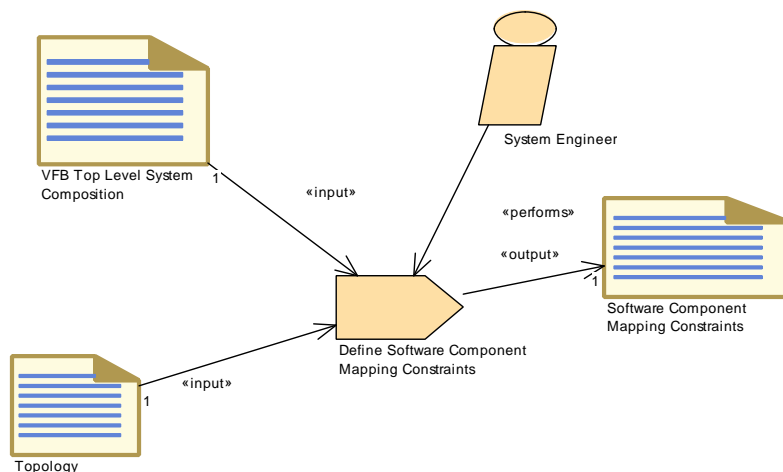


**Figure 3.37: Define System Topology**

<b>Task Definition</b>	<b>Define System Topology</b>		
<b>Package</b>	AUTOSAR Root::M2::Methodology::Methodology Library::System::Tasks		
<b>Brief Description</b>	Select the ECUs and how they are interconnected by networks.		
<b>Description</b>	Define how the ECUs of a system are interconnected by networks.		
<b>Relation Type</b>	<b>Related Element</b>	<b>Mul.</b>	<b>Note</b>
Performed by	System Engineer	1	
Consumes	ECU Resources Description	1..*	
Produces	Topology	1	

**Table 3.83: Define System Topology**

### 3.3.1.5 Define Software Component Mapping Constraints

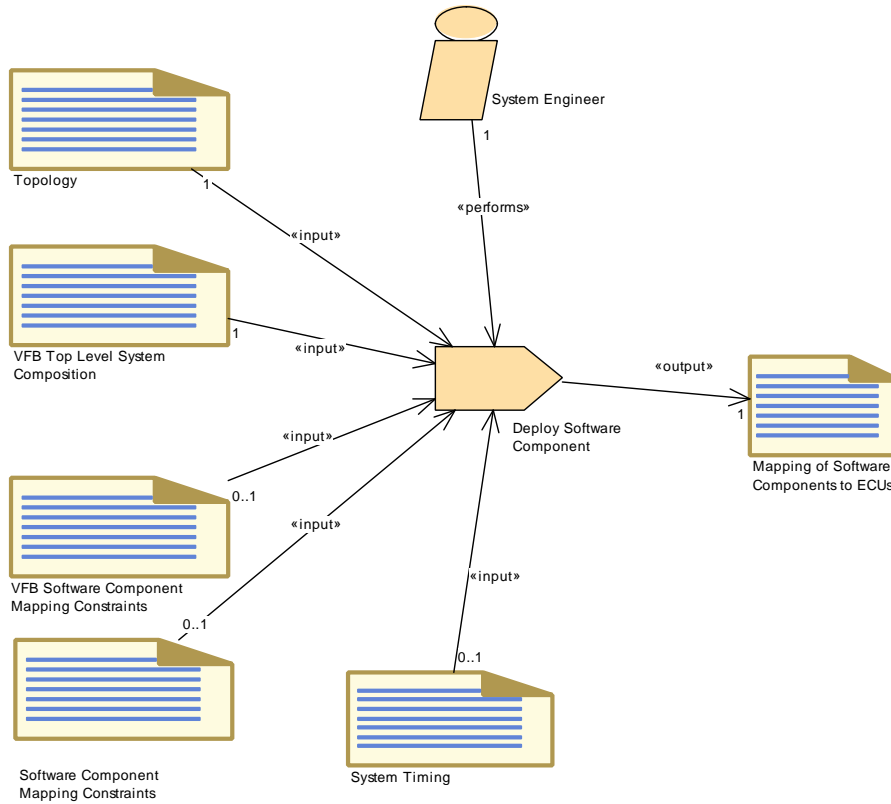


**Figure 3.38: Define Software Component Mapping Constraints**

<b>Task Definition</b>	<b>Define Software Component Mapping Constraints</b>		
<b>Package</b>	AUTOSAR Root::M2::Methodology::Methodology Library::System::Tasks		
<b>Brief Description</b>	Define Constraints on software components that are clustered together or separate, and how software components need to be assigned to a particular ECU or not.		
<b>Description</b>	<p>Define constraints on Software Components during the mapping phase. These constraints are described into the System Constraint description. Two constraints express the restrictions that Software Components impose each other when performing the mapping onto the ECUs.</p> <p>In fact, before the mapping process begins, it can be useful to impose the allocation of a predefined set of SW components onto the same ECU, especially if such a set is tightly linked from a functional point of view. In the same way, two critical SW components, performing some kind of redundancy, may be not suitable to run both on the same ECU. Thus, we call these two kinds of mapping constraints, respectively, ComponentClustering and ComponentSeparation.</p> <p>The ComponentClustering constraint (also, clustering) is to be used for expressing that a certain set of SW components (atomic or not) must be mapped (allocated) onto the same ECU. This is some kind of "execute together on same ECU" constraint.</p> <p>The ComponentSeparation constraint (also, separation) is to be used for expressing that two SW components (atomic or not) shall not be mapped (allocated) onto the same ECU. This is some kind of do not execute together on same ECU constraint.</p>		
<b>Relation Type</b>	<b>Related Element</b>	<b>Mul.</b>	<b>Note</b>
Performed by	<a href="#">System Engineer</a>	1	
Consumes	<a href="#">Topology</a>	1	
Consumes	<a href="#">VFB Top Level System Composition</a>	1	
Produces	<a href="#">Software Component Mapping Constraints</a>	1	

**Table 3.84: Define Software Component Mapping Constraints**

### 3.3.1.6 Deploy Software Component



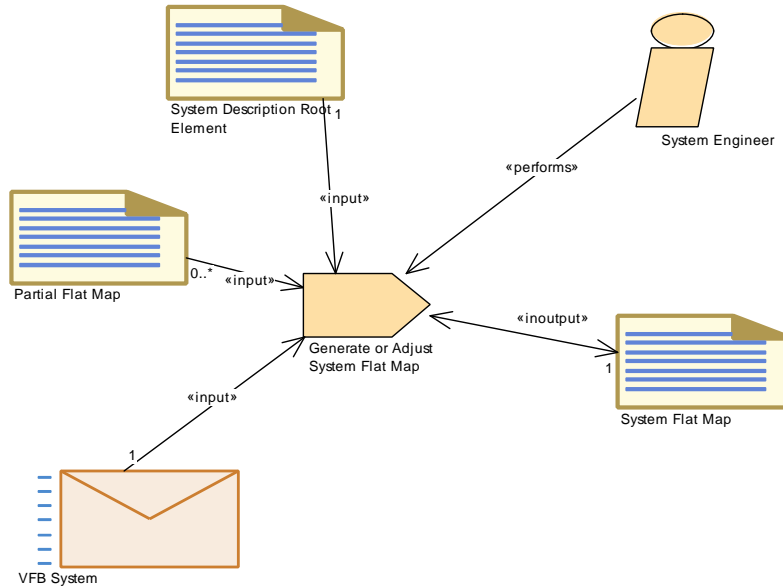
**Figure 3.39: Deploy Software Component**

<i>Task Definition</i>	<b>Deploy Software Component</b>		
<b>Package</b>	AUTOSAR Root::M2::Methodology::Methodology Library::System::Tasks		
<b>Brief Description</b>	Deploy VFB Software Components to an ECU		
<b>Description</b>	Deploy each VFB Software Component to an ECU that will execute the component.		
<i>Relation Type</i>	<i>Related Element</i>	<i>Mul.</i>	<i>Note</i>
Performed by	System Engineer	1	
Consumes	Topology	1	
Consumes	VFB Top Level System Composition	1	
Consumes	Software Component Mapping Constraints	0..1	Constraints defined on the System level
Consumes	System Timing	0..1	
Consumes	VFB Software Component Mapping Constraints	0..1	Constraints defined on the VFB level
Produces	Mapping of Software Components to ECUs	1	

Relation Type	Related Element	Mul.	Note
---------------	-----------------	------	------

**Table 3.85: Deploy Software Component**

**3.3.1.7 Generate or Adjust System Flat Map**



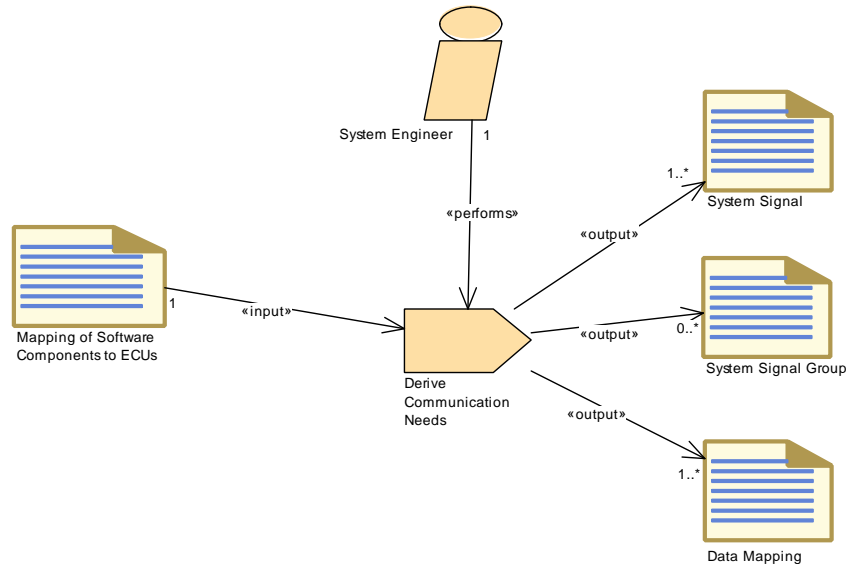
**Figure 3.40: Generate or Adjust System Flat Map**

Task Definition	Generate or Adjust System Flat Map		
Package	AUTOSAR Root::M2::Methodology::Methodology Library::System::Tasks		
Brief Description	Generates and/or adjust the unique names of component prototypes and MCD display data in the scope of system.		
Description	Generates and/or adjust the unique names of component prototypes and MCD display data in the scope of a System or System Extract.		
Relation Type	Related Element	Mul.	Note
Performed by	System Engineer	1	
Consumes	System Description Root Element	1	
Consumes	VFB System	1	
Consumes	Partial Flat Map	0..*	If Partial Flat Maps were delivered along with software components, they must be integrated into the System Flat Map: <ul style="list-style-type: none"> <li>• The instance refs used in a partial flat map must be taken over and adjusted to the context of the System or System Extract.</li> <li>• Name conflicts have to be resolved if several partial flat maps are merged.</li> </ul>

Relation Type	Related Element	Mul.	Note
In/out	<a href="#">System Flat Map</a>	1	

**Table 3.86: Generate or Adjust System Flat Map**

### 3.3.1.8 Derive Communication Needs

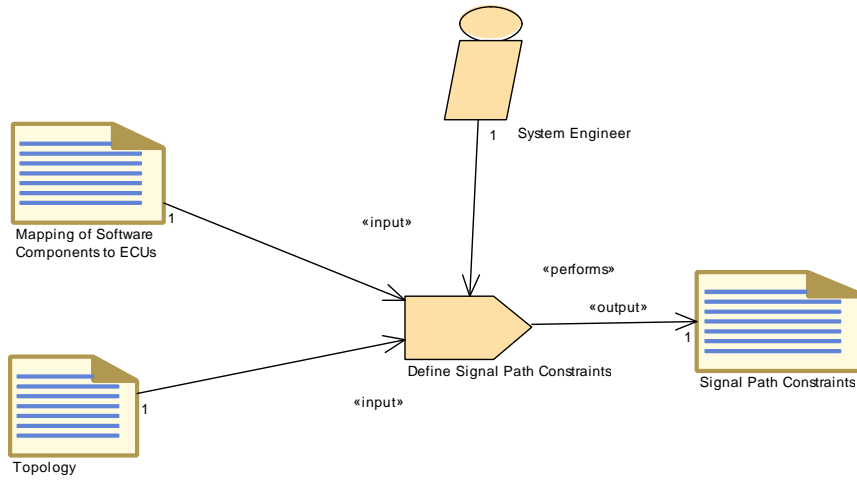


**Figure 3.41: Derive Communication Needs**

Task Definition	Derive Communication Needs		
Package	AUTOSAR Root::M2::Methodology::Methodology Library::System::Tasks		
Brief Description	Define the signals used to exchange data & operations needed by software components over a network.		
Description	Define the signals used to exchange data & operations needed by software components over a network.		
Relation Type	Related Element	Mul.	Note
Performed by	<a href="#">System Engineer</a>	1	
Consumes	<a href="#">Mapping of Software Components to ECUs</a>	1	
Produces	<a href="#">Data Mapping</a>	1..*	
Produces	<a href="#">System Signal</a>	1..*	
Produces	<a href="#">System Signal Group</a>	0..*	

**Table 3.87: Derive Communication Needs**

### 3.3.1.9 Define Signal Path Constraints

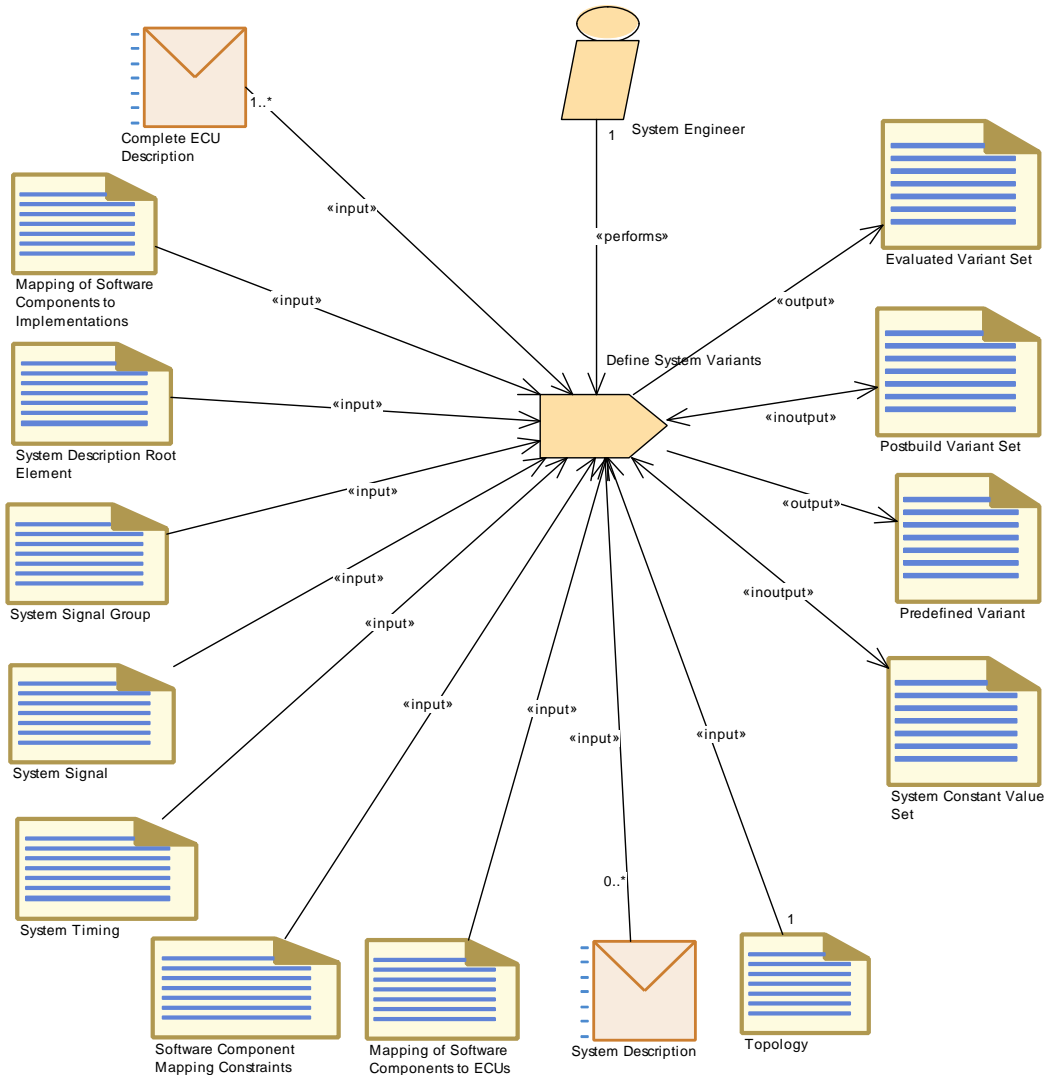


**Figure 3.42: Define Signal Path Constraints**

<b>Task Definition</b>	<b>Define Signal Path Constraints</b>		
<b>Package</b>	AUTOSAR Root::M2::Methodology::Methodology Library::System::Tasks		
<b>Brief Description</b>	Additional guidelines for the System Generator, which specific way a signal between two Software Components should take in the network without defining in which frame and with which timing it is transmitted.		
<b>Description</b>	Define additional guidelines for the System Generator, which specific way a signal between two Software Components should take in the network without defining in which frame and with which timing it is transmitted.		
<b>Relation Type</b>	<b>Related Element</b>	<b>Mul.</b>	<b>Note</b>
Performed by	System Engineer	1	
Consumes	Mapping of Software Components to ECUs	1	
Consumes	Topology	1	
Produces	Signal Path Constraints	1	

**Table 3.88: Define Signal Path Constraints**

### 3.3.1.10 Define System Variants



**Figure 3.43: Define System Variants**

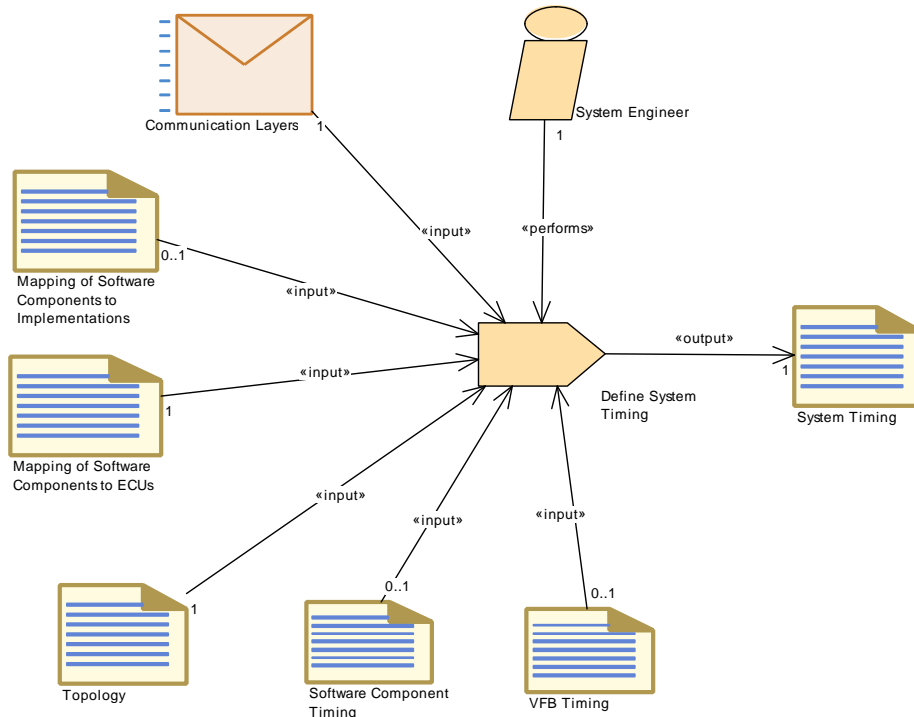
<b>Task Definition</b>	<b>Define System Variants</b>		
<b>Package</b>	AUTOSAR Root::M2::Methodology::Methodology Library::System::Tasks		
<b>Brief Description</b>	Define variants for the artifacts of a System Description.		
<b>Description</b>	Define variants for the artifacts of a System Description. Definition of a variant means in general to define its conditions and its latest binding time. Therefore one has to create a PredefinedVariant referring to the settings which are used by the system elements in scope. To do so, this task can make use of existing System Constant Value Set s and/or Postbuid Variant Set s or define new ones. Several PredefinedVariant s can be combined to one Evaluated Variant Set . This task can also be applied when designing a subsystem, therefore the System Extract is an optional input.		
<b>Relation Type</b>	<b>Related Element</b>	<b>Mul.</b>	<b>Note</b>
Performed by	System Engineer	1	



<i>Relation Type</i>	<i>Related Element</i>	<i>Mul.</i>	<i>Note</i>
Consumes	Mapping of Software Components to ECUs	1	
Consumes	Mapping of Software Components to Implementations	1	
Consumes	Software Component Mapping Constraints	1	
Consumes	System Description Root Element	1	
Consumes	System Signal	1	
Consumes	System Signal Group	1	
Consumes	System Timing	1	
Consumes	Topology	1	
Consumes	Complete ECU Description	1..*	
Consumes	System Description	0..*	
In/out	Postbuild Variant Set	1	
In/out	System Constant Value Set	1	
Produces	Evaluated Variant Set	1	
Produces	Predefined Variant	1	

**Table 3.89: Define System Variants**

**3.3.1.11 Define System Timing**



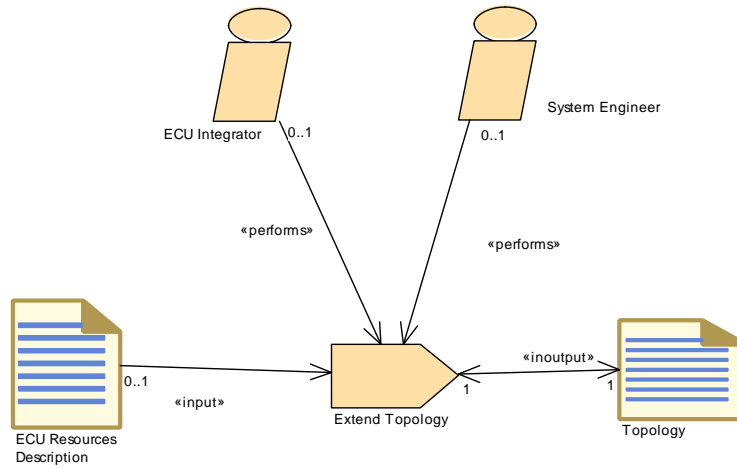
**Figure 3.44: Define System Timing**

<b>Task Definition</b>	<b>Define System Timing</b>		
<b>Package</b>	AUTOSAR Root::M2::Methodology::Methodology Library::System::Tasks		
<b>Brief Description</b>	Define SystemTiming for a concrete system taking the mapping of software components to ECUs and their implementation into account		
<b>Description</b>	Define SystemTiming (TimingDescription and TimingConstraints) for a concrete system taking the mapping of software components to ECUs and their implementation into account. This means that the resulting Communication Matrix (and its implication to the communication stack) can also be referenced by the timing specification to refine remote communication timing behavior.		
<b>Relation Type</b>	<b>Related Element</b>	<b>Mul.</b>	<b>Note</b>
Performed by	System Engineer	1	
Consumes	Communication Layers	1	
Consumes	Mapping of Software Components to ECUs	1	
Consumes	Topology	1	
Consumes	Mapping of Software Components to Implementations	0..1	
Consumes	Software Component Timing	0..1	
Consumes	VFB Timing	0..1	

Relation Type	Related Element	Mul.	Note
Produces	<a href="#">System Timing</a>	1	

**Table 3.90: Define System Timing**

**3.3.1.12 Extend Topology**

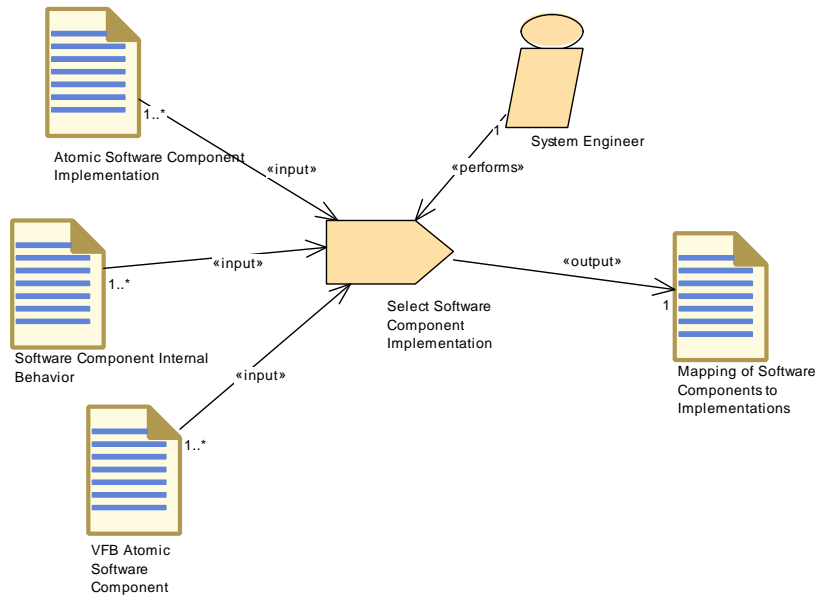


**Figure 3.45: Extend Topology**

<b>Task Definition</b>	<b>Extend Topology</b>		
<b>Package</b>	AUTOSAR Root::M2::Methodology::Methodology Library::System::Tasks		
<b>Brief Description</b>	Extend the existing System Topology		
<b>Description</b>	Extend the existing System Topology by describing how new ECUs will be connected to the existing one through the current network		
<b>Relation Type</b>	<b>Related Element</b>	<b>Mul.</b>	<b>Note</b>
Performed by	<a href="#">ECU Integrator</a>	0..1	
Performed by	<a href="#">System Engineer</a>	0..1	
Consumes	<a href="#">ECU Resources Description</a>	0..1	
In/out	<a href="#">Topology</a>	1	

**Table 3.91: Extend Topology**

### 3.3.1.13 Select Software Component Implementation

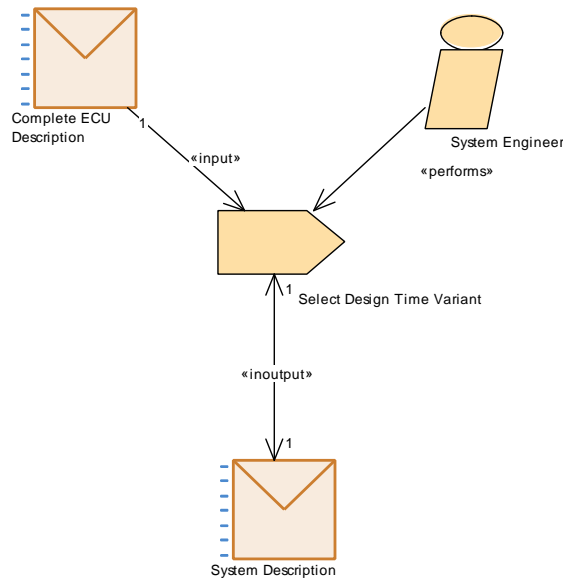


**Figure 3.46: Select Software Component Implementation**

<b>Task Definition</b>	<b>Select Software Component Implementation</b>		
<b>Package</b>	AUTOSAR Root::M2::Methodology::Methodology Library::System::Tasks		
<b>Brief Description</b>	Select implementation for an Atomic Software Component.		
<b>Description</b>	The system engineer selects an Atomic Software Component Implementation for each defined VFB Atomic Software Component		
<b>Relation Type</b>	<b>Related Element</b>	<b>Mul.</b>	<b>Note</b>
Performed by	System Engineer	1	
Consumes	Atomic Software Component Implementation	1..*	
Consumes	Software Component Internal Behavior	1..*	
Consumes	VFB Atomic Software Component	1..*	
Produces	Mapping of Software Components to Implementations	1	

**Table 3.92: Select Software Component Implementation**

**3.3.1.14 Select Design Time Variant**



**Figure 3.47: Select Design Time Variant**

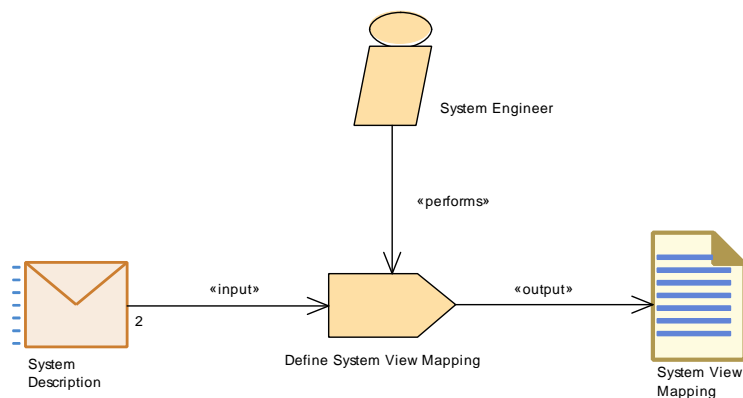
<b>Task Definition</b>	<b>Select Design Time Variant</b>		
<b>Package</b>	AUTOSAR Root::M2::Methodology::Methodology Library::System::Tasks		
<b>Brief Description</b>	Select a system variant at system design time.		
<b>Description</b>	<p>Select a system variant at system design time. This could be done in different ways: Replace a model, which contains the variation points contributing to this particular variant and all the possible settings/elements, by a model, which does no more contain these variation points and which contains only the particular settings/elements selected for this variant. In order to document the selection for further process steps, it is also possible to keep the information about the selected variant and the variation points in the model by introducing a PredefinedVariant along with appropriate fixed settings of system constant values. In constrast to variant selection in later process steps, no code generation or compilation is involved at system design time, thus this task is just a transformation of one XML model into another one. This task can be applied to a complete system description, represented by a System Extract</p> <p>Meth.bindingTime = SystemDesignTime</p>		
<b>Relation Type</b>	<b>Related Element</b>	<b>Mul.</b>	<b>Note</b>
Performed by	System Engineer	1	
Consumes	Complete ECU Description	1	
In/out	System Description	1	

**Table 3.93: Select Design Time Variant**

### 3.3.1.15 Define System View Mapping

The task *Define System View Mapping* (see Figure 3.48) creates the *System View Mapping* between two *System Descriptions*. Different cases can be separated:

- Mapping of different overall VFB systems - the *Abstract System Description* and the *System Configuration Description*.
- Mapping of different structured *System Extracts*, e.g. *System Extract* delivered by a primary organization and the different structure (*ECU System Description*) of the secondary organization (see 2.5.4, 2.5.5).



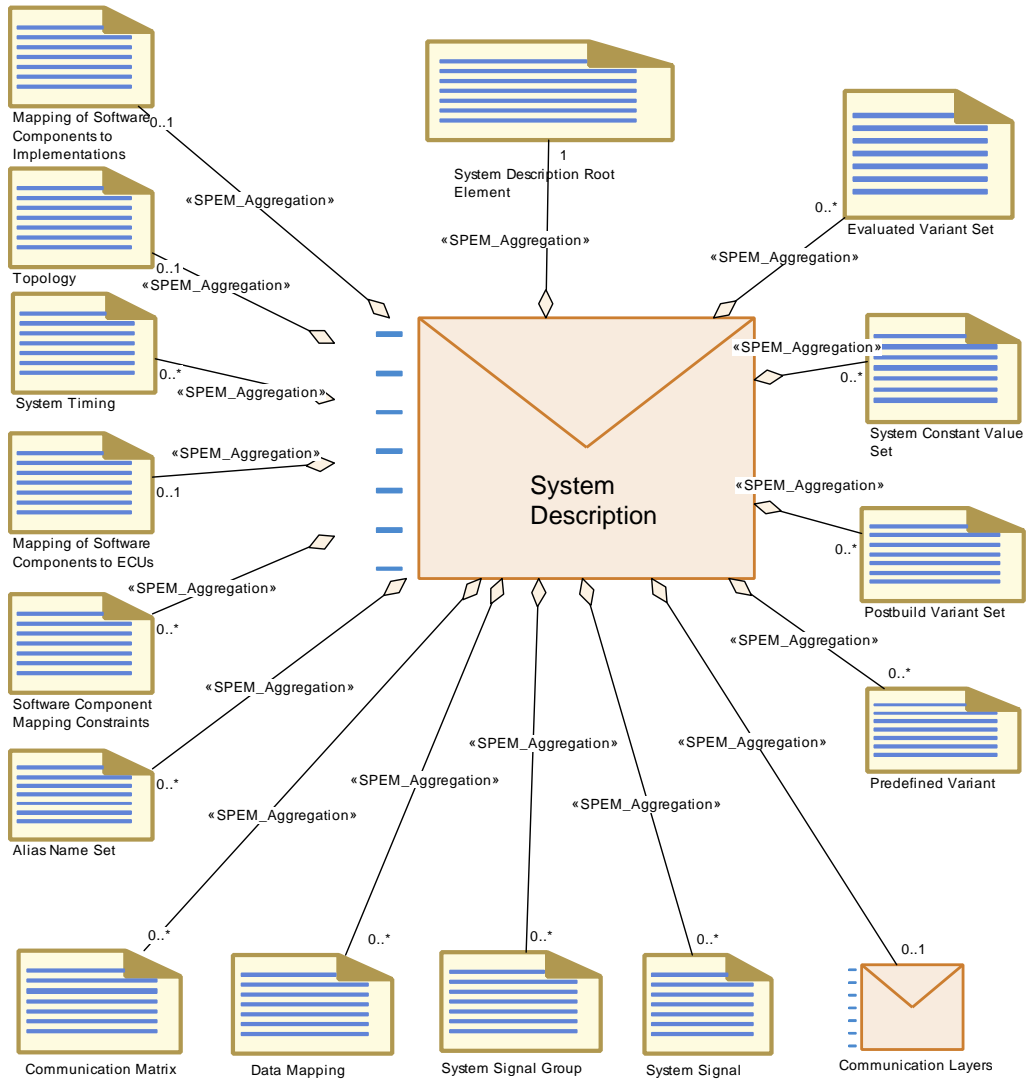
**Figure 3.48: Define System View Mapping**

<b>Task Definition</b>	<b>Define System View Mapping</b>		
<b>Package</b>	AUTOSAR Root::M2::Methodology::Methodology Library::System::Tasks		
<b>Brief Description</b>	Map elements from different views on the system.		
<b>Description</b>	This task creates the System View Mapping between two System Descriptions (Mapping of different structured system descriptions, e.g. system extract delivered by a primary organization and the different structure of the secondary organisation).		
<b>Relation Type</b>	<b>Related Element</b>	<b>Mul.</b>	<b>Note</b>
Performed by	System Engineer	1	
Consumes	System Description	2	
Produces	System View Mapping	1	

**Table 3.94: Define System View Mapping**

### 3.3.2 Work Products

#### 3.3.2.1 System Description



**Figure 3.49: Structure of generic deliverable System Description**

<b>Deliverable</b>	<b>System Description</b>		
<b>Package</b>	AUTOSAR Root::M2::Methodology::Methodology Library::System:: Work products		
<b>Brief Description</b>	Partial Extract of a System		
<b>Description</b>	<p>Generic deliverable for defining a System. It is used in different roles within the methodology.</p> <p>In each role, this deliverable may contain variation points in its ARXML artifacts which need to be bound in later steps, e.g. when defining a subsystem from a complete system or later for the single ECUs. If such variation points are present, the System Description may optionally include PredefinedVariants in order to predefine variants for later selection and an Evaluated Variant Set.</p> <p>Please note that this generic deliverable does not correspond to the system description with the system category "SYSTEM_DESCRIPTION" (see [TPS_SYST_01003]). The system description with the category "SYSTEM_DESCRIPTION" is represented by the deliverable "System Configuration Description".</p> <p>This deliverable is equivalent to a description of a system with any category. In the System Template Specification "system description" is the most frequently used term for this kind of artifact.</p>		
<b>Kind</b>	Delivered		
<b>Extended by</b>	<a href="#">Abstract System Description</a> , <a href="#">System Configuration Description</a> , <a href="#">System Constraint Description</a> , <a href="#">System Extract</a>		
<b>Relation Type</b>	<b>Related Element</b>	<b>Mul.</b>	<b>Note</b>
Aggregates	<a href="#">System Description Root Element</a>	1	
Aggregates	<a href="#">Communication Layers</a>	0..1	
Aggregates	<a href="#">Mapping of Software Components to ECUs</a>	0..1	
Aggregates	<a href="#">Mapping of Software Components to Implementations</a>	0..1	
Aggregates	<a href="#">Topology</a>	0..1	
Aggregates	<a href="#">Alias Name Set</a>	0..*	
Aggregates	<a href="#">Communication Matrix</a>	0..*	
Aggregates	<a href="#">Data Mapping</a>	0..*	
Aggregates	<a href="#">Evaluated Variant Set</a>	0..*	
Aggregates	<a href="#">Postbuild Variant Set</a>	0..*	
Aggregates	<a href="#">Predefined Variant</a>	0..*	
Aggregates	<a href="#">Software Component Mapping Constraints</a>	0..*	
Aggregates	<a href="#">System Constant Value Set</a>	0..*	



<i>Relation Type</i>	<i>Related Element</i>	<i>Mul.</i>	<i>Note</i>
Aggregates	<a href="#">System Signal</a>	0..*	
Aggregates	<a href="#">System Signal Group</a>	0..*	
Aggregates	<a href="#">System Timing</a>	0..*	
In/out	<a href="#">Select Design Time Variant</a>	1	
Consumed by	<a href="#">Define System View Mapping</a>	2	
Consumed by	<a href="#">Define Alias Names</a>	0..1	Needed for definition of alias names with system, system extract or ECU scope, depending of the role of the System Description.
Consumed by	<a href="#">Define System Variants</a>	0..*	

**Table 3.95: System Description**

<i>Deliverable</i>	<i>System Constraint Description</i>		
<b>Package</b>	AUTOSAR Root::M2::Methodology::Methodology Library::System::Work products		
<b>Brief Description</b>			
<b>Description</b>	<p>Contains the artifacts that describe System Constraints. It serves as an input for setting up the complete Abstract System Description and/or System Configuration Description.</p> <p>This deliverable corresponds to the system description with the system category "SYSTEM_CONSTRAINTS" (see [TPS_SYST_01003]).</p>		
<b>Kind</b>	Delivered		
<b>Extends</b>	<a href="#">System Description</a>		
<i>Relation Type</i>	<i>Related Element</i>	<i>Mul.</i>	<i>Note</i>
Aggregates	<a href="#">Overall VFB System</a>	0..1	
Aggregates	<a href="#">System Flat Map</a>	0..1	
Consumed by	<a href="#">Develop System</a>	0..1	
Consumed by	<a href="#">Develop an Abstract System Description</a>	0..1	In the context of the "Develop an Abstract System Description" activity, the constraints for the abstract or functional view on the system can be provided by the "System Constraint Description".

**Table 3.96: System Constraint Description**

<b>Deliverable</b>	<b>System Configuration Description</b>		
<b>Package</b>	AUTOSAR Root::M2::Methodology::Methodology Library::System::Work products		
<b>Brief Description</b>			
<b>Description</b>	<p>Contains the artifacts that describe a complete AUTOSAR System. It is the basis for extracting descriptions for sub-systems or ECUs.</p> <p>Note that System Extracts may be refined by details which are not present in the System Configuration.</p> <p>This deliverable corresponds to the system description with the system category "SYSTEM_DESCRIPTION" (see [TPS_SYST_01003]).</p>		
<b>Kind</b>	Delivered		
<b>Extends</b>	<a href="#">System Description</a>		
<b>Relation Type</b>	<b>Related Element</b>	<b>Mul.</b>	<b>Note</b>
Aggregates	<a href="#">Overall VFB System</a>	1	
Aggregates	<a href="#">System Flat Map</a>	0..1	
Produced by	<a href="#">Develop System</a>	1..*	
Consumed by	<a href="#">Generate System Extract</a>	1	
Consumed by	<a href="#">Generate ECU Extract</a>	0..1	

**Table 3.97: System Configuration Description**

<b>Deliverable</b>	<b>System Extract</b>		
<b>Package</b>	AUTOSAR Root::M2::Methodology::Methodology Library::System::Work products		
<b>Brief Description</b>			
<b>Description</b>	<p>Contains the artifacts that describe a subsystem specific view on the complete System Description. Initially, the System Extract is not fully decomposed and still contains compositions. It is the basis for designing subsystems, e.g. by adding further ECUs within the given constraints.</p> <p>This deliverable corresponds to the system description with the system category "SYSTEM_EXTRACT" (see [TPS_SYST_01003]).</p>		
<b>Kind</b>	Delivered		
<b>Extended by</b>	<a href="#">ECU System Description</a>		
<b>Extends</b>	<a href="#">System Description</a>		
<b>Relation Type</b>	<b>Related Element</b>	<b>Mul.</b>	<b>Note</b>
Aggregates	<a href="#">VFB System Extract</a>	1	
Aggregates	<a href="#">System Flat Map</a>	0..1	
Produced by	<a href="#">Develop System</a>	0..*	
Produced by	<a href="#">Generate System Extract</a>	0..*	
Consumed by	<a href="#">Create ECU System Description</a>	1	

<i>Relation Type</i>	<i>Related Element</i>	<i>Mul.</i>	<i>Note</i>
Consumed by	<a href="#">Develop Sub-System</a>	1	
Consumed by	<a href="#">Generate ECU Extract</a>	0..1	

**Table 3.98: System Extract**

<i>Deliverable</i>	<b>ECU System Description</b>		
<b>Package</b>	AUTOSAR Root::M2::Methodology::Methodology Library::System::Work products		
<b>Brief Description</b>			
<b>Description</b>	<p>This System Description is used to describe the closed view on one ECU (note that an AUTOSAR ECU is defined being one microprocessor running one AUTOSAR Stack). It can be derived from a System Extract or it can be designed independently and mapped to a System Extract. The ECU System Description is not fully decomposed and still may contain compositions.</p> <p>It is refined during the activity Design Sub-System.</p> <p>This deliverable corresponds to the system description with the system category "ECU_SYSTEM_DESCRIPTION" (see [TPS_SYST_01003]).</p>		
<b>Kind</b>			
<b>Extends</b>	<a href="#">System Extract</a>		
<i>Relation Type</i>	<i>Related Element</i>	<i>Mul.</i>	<i>Note</i>
Produced by	<a href="#">Design Sub-System</a>	1	System Extract refined during design of the corresponding sub-system with elements needed to generate ECU Extract(s).
Produced by	<a href="#">Create ECU System Description</a>	1..*	
Consumed by	<a href="#">Design Sub-System</a>	1	System Extract as generated from the outer system.
Consumed by	<a href="#">Generate ECU Extract</a>	0..1	

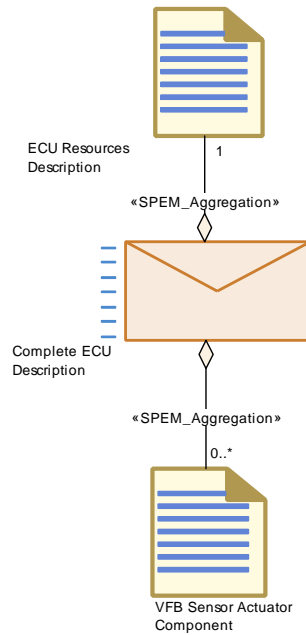
**Table 3.99: ECU System Description**

### 3.3.2.2 Abstract System Description

<b>Deliverable</b>	<b>Abstract System Description</b>		
<b>Package</b>	AUTOSAR Root::M2::Methodology::Methodology Library::System::Work products		
<b>Brief Description</b>	Provides an abstract or functional view on the system		
<b>Description</b>	<p>The Abstract System Description extends the general System Description and provides an abstract or functional view on the system to be developed.</p> <p>This deliverable corresponds to the system description with the system category "ABSTRACT_SYSTEM_DESCRIPTION" (see [TPS_SYST_01003]).</p>		
<b>Kind</b>	Delivered		
<b>Extends</b>	<a href="#">System Description</a>		
<b>Relation Type</b>	<b>Related Element</b>	<b>Mul.</b>	<b>Note</b>
Aggregates	<a href="#">Overall VFB System</a>	1	
Produced by	<a href="#">Develop an Abstract System Description</a>	1..*	
Consumed by	<a href="#">Develop System</a>	0..*	The abstract System Description is an optional input for the activity "Develop System". Please note, that in this step the Abstract System Description is refined to a System Description.
Consumed by	<a href="#">Develop a VFB System Description</a>	0..*	The abstract System Description is an optional input for the activity "Develop a VFB System Description". The VFB-related part of the Abstract System Description can be then refined to the concrete "Overall VFB System". Additionally, a mapping between those two views can be established.

**Table 3.100: Abstract System Description**

### 3.3.2.3 Complete ECU Description



**Figure 3.50: Complete ECU Description**

<b>Deliverable</b>	<b>Complete ECU Description</b>		
<b>Package</b>	AUTOSAR Root::M2::Methodology::Methodology Library::System:: Work products		
<b>Brief Description</b>	An ECU Description includes the resources it has available along with its corresponding ECU-specific software components.		
<b>Description</b>	An ECU Description includes the resources it has available along with its corresponding ECU-specific software components.		
<b>Kind</b>	Delivered		
<b>Relation Type</b>	<b>Related Element</b>	<b>Mul.</b>	<b>Note</b>
Aggregates	<a href="#">ECU Resources Description</a>	1	
Aggregates	<a href="#">VFB Sensor Actuator Component</a>	0..*	
Consumed by	<a href="#">Select Design Time Variant</a>	1	
Consumed by	<a href="#">Define System Variants</a>	1..*	

**Table 3.101: Complete ECU Description**

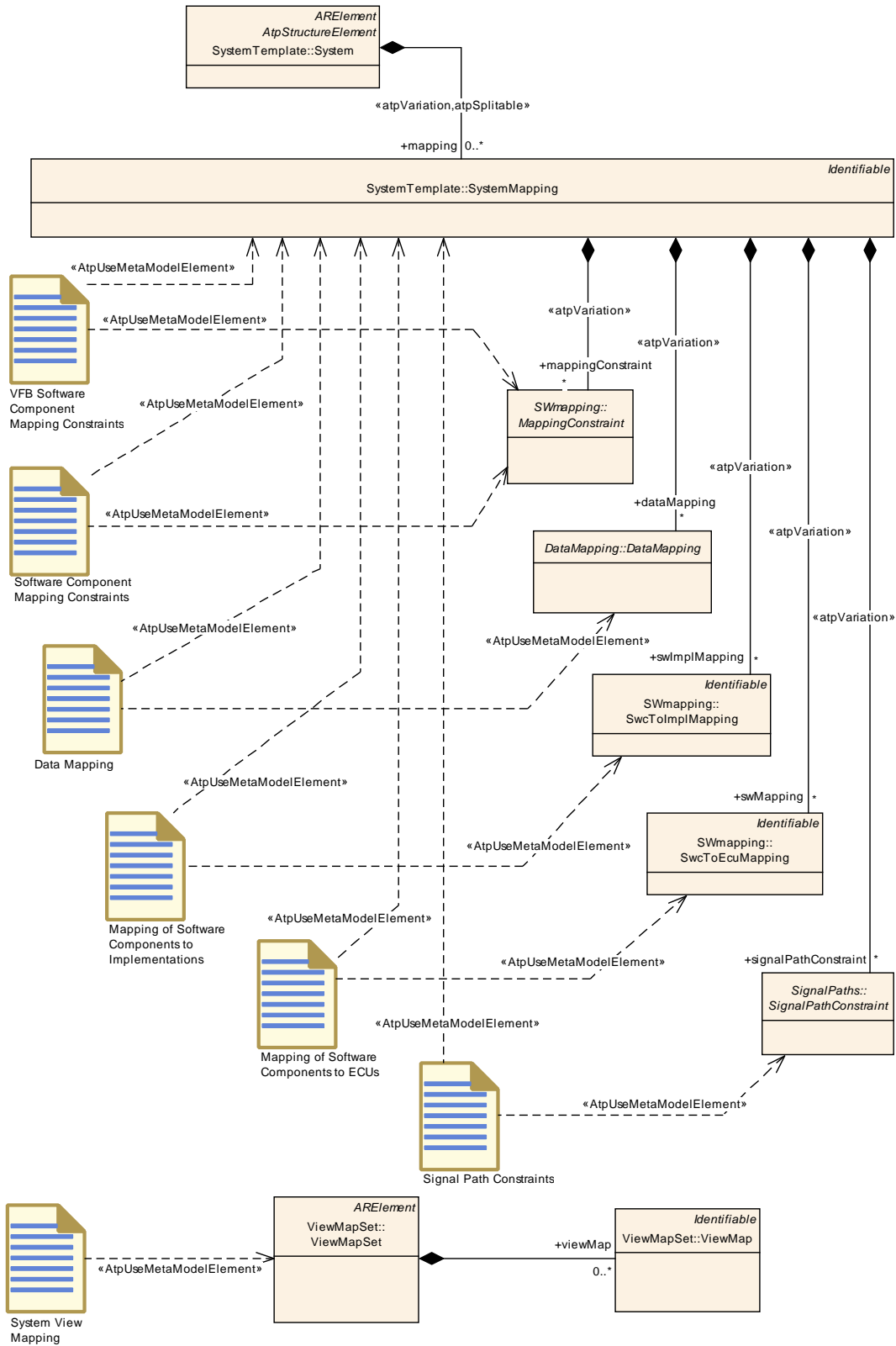
### 3.3.2.4 System Description Root Element

<b>Artifact</b>	<b>System Description Root Element</b>		
<b>Package</b>	AUTOSAR Root::M2::Methodology::Methodology Library::System::Work products		
<b>Brief Description</b>	A System Description root element.		
<b>Description</b>	<p>The System description defines the following major elements:</p> <ul style="list-style-type: none"> <li>• Topology : description of the Topology of the System.</li> <li>• Software : description of the root software composition containing all software components in the System in a hierarchical structure.</li> <li>• Communication : description of all Communication elements used in the System.</li> <li>• Mapping and Mapping Constraints : description of all mapping aspects (mapping of SW components to ECUs, mapping of data elements to signals, and mapping constraints).</li> </ul> <p>The root element can be the basis for a System extract as well as for the whole System depending on which elements are aggregated.</p>		
<b>Kind</b>	AUTOSAR XML		
<b>Relation Type</b>	<b>Related Element</b>	<b>Mul.</b>	<b>Note</b>
Aggregated by	<a href="#">System Description</a>	1	
Produced by	<a href="#">Assign Top Level Composition</a>	1	
Produced by	<a href="#">Set System Root</a>	1	Set up the root element, and the links to other artifacts
Consumed by	<a href="#">Define System Variants</a>	1	
Consumed by	<a href="#">Flatten Software Composition</a>	1	find the top level composition
Consumed by	<a href="#">Generate or Adjust System Flat Map</a>	1	
Use meta model element	System	1	

**Table 3.102: System Description Root Element**

### 3.3.2.5 System Mapping Overview

There are various artifacts which correspond to the mappings collected under the meta-model element `SystemMapping`. Figure 3.51 shows an overview. The details will be explained in the following sub-chapters.



**Figure 3.51: Overview on the various artifacts for System Mapping**

### 3.3.2.6 Software Component Mapping Constraints

<b>Artifact</b>	<b>Software Component Mapping Constraints</b>		
<b>Package</b>	AUTOSAR Root::M2::Methodology::Methodology Library::System::Work products		
<b>Brief Description</b>	Defined constraints on how certain components must be mapped (clustered or separated).		
<b>Description</b>	<p>Description of one or more constraints on Software Components during mapping to the ECUs. Three type of constraints have been defined:</p> <p>The ComponentClustering constraint (also, clustering) is to be used for expressing that a certain set of SW components (atomic or not) must be mapped (allocated) onto the same ECU. This is some kind of "execute together on same ECU" constraint. The semantic of the clustering constraint is straightforward if all concerned SW components are atomic. Otherwise, it shall be interpreted as follows: all of the atomic SW components making up the composition must be mapped together onto the same ECU together with all other SW components (atomic or not) affected by the constraint. This also means that a clustering constraint can also refer to only a single composition.</p> <p>The ComponentSeparation constraint (also, separation) is to be used for expressing that two SW components (atomic or not) shall not be mapped (allocated) onto the same ECU. This is some kind of do not execute together on same ECU constraint. The semantic of the separation constraint is straightforward if one or both SW components are atomic. Otherwise, it shall be interpreted as follows: any of the atomic SW components making up the first composition, must not be mapped onto the same ECU with any atomic SW component from the second composition. As a consequence, and to preserve consistency, an atomic SW component instance cannot be part of two compositions concerned by the same separation constraint, i.e. the two compositions have to be disjoint with regards to component instances.</p> <p>SwcToEcuMapping constraint: The System Constraint Description has to describe dedicated and exclusive mapping of SW-Cs to one or more ECUs.</p>		
<b>Kind</b>	AUTOSAR XML		
<b>Relation Type</b>	<b>Related Element</b>	<b>Mul.</b>	<b>Note</b>
Aggregated by	<a href="#">System Description</a>	0..*	
Produced by	<a href="#">Define Software Component Mapping Constraints</a>	1	
Consumed by	<a href="#">Define System Variants</a>	1	
Consumed by	<a href="#">Set System Root</a>	1	Only the reference to the artifact is needed
Consumed by	<a href="#">Deploy Software Component</a>	0..1	Constraints defined on the System level
Use meta model element	MappingConstraint	1	
Use meta model element	SystemMapping	1	The splitable element SystemMapping is the root for this artifact.



<i>Relation Type</i>	<i>Related Element</i>	<i>Mul.</i>	<i>Note</i>
----------------------	------------------------	-------------	-------------

**Table 3.103: Software Component Mapping Constraints**

### 3.3.2.7 Data Mapping

<i>Artifact</i>	<b>Data Mapping</b>		
<b>Package</b>	AUTOSAR Root::M2::Methodology::Methodology Library::System::Work products		
<b>Brief Description</b>			
<b>Description</b>	Mapping of data prototypes from the VFB description to System signals.		
<b>Kind</b>	AUTOSAR XML		
<i>Relation Type</i>	<i>Related Element</i>	<i>Mul.</i>	<i>Note</i>
Aggregated by	<a href="#">System Description</a>	0..*	
Produced by	<a href="#">Derive Communication Needs</a>	1..*	
Consumed by	<a href="#">Define Signal PDUs</a>	1	
Consumed by	<a href="#">Flatten Software Composition</a>	1..*	
Consumed by	<a href="#">Set System Root</a>	1..*	Only the reference to the artifact is needed
Use meta model element	DataMapping	1	
Use meta model element	SystemMapping	1	The splittable element SystemMapping is the root for this artifact.

**Table 3.104: Data Mapping**

### 3.3.2.8 Mapping of Software Components to ECUs

<i>Artifact</i>	<b>Mapping of Software Components to ECUs</b>		
<b>Package</b>	AUTOSAR Root::M2::Methodology::Methodology Library::System::Work products		
<b>Brief Description</b>	Describes the mapping of Software Components to the ECUs that are defined in the VFB context.		
<b>Description</b>	The VFB shows all Software Components independently of their deployment on individual ECUs. This work product defines for each Software Component the corresponding ECU on which the Software Component will be deployed and executed.		
<b>Kind</b>	AUTOSAR XML		
<i>Relation Type</i>	<i>Related Element</i>	<i>Mul.</i>	<i>Note</i>
Aggregated by	<a href="#">System Description</a>	0..1	
Produced by	<a href="#">Deploy Software Component</a>	1	
Consumed by	<a href="#">Define Signal PDUs</a>	1	

<b>Relation Type</b>	<b>Related Element</b>	<b>Mul.</b>	<b>Note</b>
Consumed by	Define Signal Path Constraints	1	
Consumed by	Define System Timing	1	
Consumed by	Define System Variants	1	
Consumed by	Derive Communication Needs	1	
Consumed by	Extract the ECU Communication	1	
Consumed by	Flatten Software Composition	1	
Consumed by	Set System Root	1	Only the reference to the artifact is needed
Use meta model element	SwcToEcuMapping	1	
Use meta model element	SystemMapping	1	The splittable element SystemMapping is the root for this artifact.

**Table 3.105: Mapping of Software Components to ECUs**

### 3.3.2.9 Mapping of Software Components to Implementations

<b>Artifact</b>	<b>Mapping of Software Components to Implementations</b>		
<b>Package</b>	AUTOSAR Root::M2::Methodology::Methodology Library::System::Work products		
<b>Brief Description</b>			
<b>Description</b>	Specifies the selection of software implementations for the atomic component prototypes. Because component prototypes can be located on different ECUs, it is possible to have different Implementations of two prototypes of the same AtomicComponentType in the system.		
<b>Kind</b>	AUTOSAR XML		
<b>Relation Type</b>	<b>Related Element</b>	<b>Mul.</b>	<b>Note</b>
Aggregated by	System Description	0..1	
Produced by	Select Software Component Implementation	1	
Consumed by	Define System Variants	1	
Consumed by	Define System Timing	0..1	
Use meta model element	SwcToImplMapping	1	
Use meta model element	SystemMapping	1	The splittable element SystemMapping is the root for this artifact..

**Table 3.106: Mapping of Software Components to Implementations**

### 3.3.2.10 Signal Path Constraints

<b>Artifact</b>	<b>Signal Path Constraints</b>		
<b>Package</b>	AUTOSAR Root::M2::Methodology::Methodology Library::System::Work products		
<b>Brief Description</b>	Constraints on the Path that should be used or not by Signals		
<b>Description</b>	<p>One of the tasks of the System Generator is actually to calculate automatically the communication (signals) between the RTEs and define the needed frames for that communication. These definitions of the frames include implicitly the definition of the paths the AUTOSAR-Signals are transmitted through the system. Thereby the System Generator often has the choice between alternative ways through the system. There exist four different constraints for signals regarding the signal path:</p> <ul style="list-style-type: none"> <li>• The CommonSignalPath describes that two signals must take the same way (Signal Path) in the topology.</li> <li>• The ForbiddenSignalPath describes the way (Signal Path) that a signal must not take in the topology, e.g. in case of safety critical transmission.</li> <li>• The PermissibleSignalPath describes the way (Signal Path) a signal can take in the topology. If more than one PermissibleSignalPath is defined for the same signal/operation attributes, any of them can be chosen.</li> <li>• The SeparateSignalPath describes that two or more signals must not take the same way (Signal Path) in the topology e.g. in case of redundant transmission. It is also possible that the same signal is aggregated two times by the SeparateSignalPath element to indicate that this signal should be transmitted redundantly over two different paths.</li> </ul>		
<b>Kind</b>	AUTOSAR XML		
<b>Relation Type</b>	<b>Related Element</b>	<b>Mul.</b>	<b>Note</b>
Produced by	<a href="#">Define Signal Path Constraints</a>	1	
Consumed by	<a href="#">Set System Root</a>	1	Only the reference to the artifact is needed
Use meta model element	SignalPathCon- straint	1	
Use meta model element	SystemMapping	1	The splitable element SystemMapping is the root for this artifact.

**Table 3.107: Signal Path Constraints**

### 3.3.2.11 Topology

<b>Artifact</b>	<b>Topology</b>		
<b>Package</b>	AUTOSAR Root::M2::Methodology::Methodology Library::System::Work products		
<b>Brief Description</b>	The system topology, which may be reused in different systems.		
<b>Description</b>	Describes the topology of the system : A topology is formed by a number of EcuInstances that are interconnected to each other in order to form ensembles of ECUs and CommunicationClusters.		
<b>Kind</b>	AUTOSAR XML		
<b>Relation Type</b>	<b>Related Element</b>	<b>Mul.</b>	<b>Note</b>
Aggregated by	<a href="#">System Description</a>	0..1	
Produced by	<a href="#">Define System Topology</a>	1	
In/out	<a href="#">Extend Topology</a>	1	
Consumed by	<a href="#">Define Communication Matrix</a>	1	
Consumed by	<a href="#">Define Network Management</a>	1	
Consumed by	<a href="#">Define Signal PD Us</a>	1	
Consumed by	<a href="#">Define Signal Path Constraints</a>	1	
Consumed by	<a href="#">Define Software Component Mapping Constraints</a>	1	
Consumed by	<a href="#">Define System Timing</a>	1	
Consumed by	<a href="#">Define System Variants</a>	1	
Consumed by	<a href="#">Define TP</a>	1	
Consumed by	<a href="#">Deploy Software Component</a>	1	
Consumed by	<a href="#">Extract ECU Topology</a>	1	
Consumed by	<a href="#">Set System Root</a>	1	Only the reference to the artifact is needed
Use meta model element	Communication Cluster	1	
Use meta model element	EcuInstance	1	

**Table 3.108: Topology**

### 3.3.2.12 Ecu Resources Description

<b>Artifact</b>	<b>ECU Resources Description</b>		
<b>Package</b>	AUTOSAR Root::M2::Methodology::Methodology Library::System::Work products		
<b>Brief Description</b>	Definition of the resources available on an ECU.		
<b>Description</b>	Definition of the resources available on an ECU. It mainly contains a description of hardware elements (like physical memory sections or peripherals, pins, hardware connections) which need to be referred by a software component or a basic software description. The focus is to describe an already engineered piece of hardware, its content and structure. It is not in the focus of the ECU Resource Description to support the design of electronics hardware itself. In the XML it is represented as a set of HwDescriptionEntity -s		
<b>Kind</b>	AUTOSAR XML		
<b>Relation Type</b>	<b>Related Element</b>	<b>Mul.</b>	<b>Note</b>
Aggregated by	<a href="#">Complete ECU Description</a>	1	
Produced by	<a href="#">Define ECU Description</a>	1..*	
Consumed by	<a href="#">Define System Topology</a>	1..*	
Consumed by	<a href="#">Define BSW Interfaces</a>	0..1	
Consumed by	<a href="#">Define ECU Abstraction Component</a>	0..1	
Consumed by	<a href="#">Extend Topology</a>	0..1	
Consumed by	<a href="#">Generate ECU Executable</a>	0..1	may be used to set up build environment Meth.bindingTime = CompileTime
Consumed by	<a href="#">Implement a BSW Module</a>	0..1	Meth.bindingTime = SystemDesignTime
Consumed by	<a href="#">Measure Component Resources</a>	0..1	
Consumed by	<a href="#">Measure Resources</a>	0..1	
Consumed by	<a href="#">Define Complex Driver Component</a>	0..*	
Consumed by	<a href="#">Define VFB Sensor or Actuator Component</a>	0..*	
Use meta model element	HwElement	1	

**Table 3.109: ECU Resources Description**

### 3.3.2.13 System Signal

<b>Artifact</b>	<b>System Signal</b>		
<b>Package</b>	AUTOSAR Root::M2::Methodology::Methodology Library::System::Work products		
<b>Brief Description</b>			
<b>Description</b>	The system signals allow to represent this communication view in a flattened structure, with (at least) one system signal defined for each data element sent or received by a SW component instance. If data has to be sent over gateways, there is still only one system signal representing this data. The representation of the data on the individual communication systems is done by the cluster signals.		
<b>Kind</b>	AUTOSAR XML		
<b>Relation Type</b>	<b>Related Element</b>	<b>Mul.</b>	<b>Note</b>
Aggregated by	<a href="#">System Description</a>	0..*	
Produced by	<a href="#">Derive Communication Needs</a>	1..*	
Consumed by	<a href="#">Define Signal PDUs</a>	1	
Consumed by	<a href="#">Define System Variants</a>	1	
Consumed by	<a href="#">Define RTE Fan-out</a>	1..*	
Consumed by	<a href="#">Extract the ECU Communication</a>	0..*	
Use meta model element	SystemSignal	1	

**Table 3.110: System Signal**

### 3.3.2.14 System Signal Group

<b>Artifact</b>	<b>System Signal Group</b>		
<b>Package</b>	AUTOSAR Root::M2::Methodology::Methodology Library::System::Work products		
<b>Brief Description</b>	A signal group refers to a set of signals that must always be kept together. A signal group is used to guarantee the atomic transfer of AUTOSAR composite data types.		
<b>Description</b>	<p>The System Signal Group is representing a set of Signals that must be kept together. A signal group is to guarantee the transfer of AUTOSAR composite data types for sender receiver communication. The RTE is required to treat AUTOSAR signals transmitted using sender-receiver communication atomically. To achieve this, the "signal group" mechanisms shall be utilized. It is not possible to map a Variable Data Prototype with a composite datatype directly to a System Signal . The complex data type must be decomposed into single signals. As this set of single signals has to be treated as atomic, it is placed in a "signal group". It is also used in client server communication when the RTE maps a response to a corresponding operation request. The arguments, application errors, client identifier and sequence counter of an operation are mapped to System Signal of two dedicated SystemSignalGroup elements; one for the request and one for the response. The RTE Client Server Protocol is used to provide a specific semantics to each of these SystemSignalGroups and System Signal , also those which are introduced only to support the protocol.</p>		
<b>Kind</b>	AUTOSAR XML		
<b>Relation Type</b>	<b>Related Element</b>	<b>Mul.</b>	<b>Note</b>
Aggregated by	<a href="#">System Description</a>	0..*	
Produced by	<a href="#">Derive Communication Needs</a>	0..*	
Consumed by	<a href="#">Define System Variants</a>	1	
Consumed by	<a href="#">Extract the ECU Communication</a>	0..*	
Use meta model element	SystemSignal Group	1	

**Table 3.111: System Signal Group**

### 3.3.2.15 System Flat Map

<b>Artifact</b>	<b>System Flat Map</b>		
<b>Package</b>	AUTOSAR Root::M2::Methodology::Methodology Library::System::Work products		
<b>Brief Description</b>	Mapping of instance names to nested model elements. Use cases: Resolve name conflicts when flattening VFB software compositions; provide unique names and unique model references for measurement and calibration data.		
<b>Description</b>	<p>The flat map is a list of elements, each element represents exactly one node (e.g. a component instance or data element) of the instance tree of a software system. The purpose of this element is to map the various nested representations of this instance to a flat representation and assign a unique name to it. The name will be unique in the scope to which this Flat Map belongs (which could be a whole System or a System Extract).</p> <p>Use case: The System Flat Map is defined in the context of a System or System Extract. It serves as a basis for generating an ECU Flat Map (or a Flat Map of a "child" System Extract). In the ECU Flat Map, the names will be used as display names for MCD tools or as names for component prototypes in a flattened software composition. For further information refer to the description of artifact ECU Flat Map.</p>		
<b>Kind</b>	AUTOSAR XML		
<b>Relation Type</b>	<b>Related Element</b>	<b>Mul.</b>	<b>Note</b>
Aggregated by	<a href="#">System Configuration Description</a>	0..1	
Aggregated by	<a href="#">System Constraint Description</a>	0..1	
Aggregated by	<a href="#">System Extract</a>	0..1	
In/out	<a href="#">Generate or Adjust System Flat Map</a>	1	
Consumed by	<a href="#">Add Documentation to the Software Component</a>	0..1	Optional input in order to refer to unique names defined in system context.
Consumed by	<a href="#">Generate or Adjust ECU Flat Map</a>	0..1	Take over definitions of unique names from system level to ECU level.
Use meta model element	FlatMap	1	

**Table 3.112: System Flat Map**

### 3.3.2.16 System Timing



<b>Artifact</b>	<b>System Timing</b>		
<b>Package</b>	AUTOSAR Root::M2::Methodology::Methodology Library::System::Work products		
<b>Brief Description</b>	Concrete system's TimingDescription and TimingConstraints		
<b>Description</b>	TimingDescription and TimingConstraints defined for a concrete system taking the mapping of software components to ECUs and their implementation into account. This means that the resulting Communication Matrix (and its implication to the communication stack) can also be referenced by the timing specification to refine remote communication timing behavior.		
<b>Kind</b>	AUTOSAR XML		
<b>Relation Type</b>	<b>Related Element</b>	<b>Mul.</b>	<b>Note</b>
Aggregated by	<a href="#">System Description</a>	0..*	
Produced by	<a href="#">Define System Timing</a>	1	
Consumed by	<a href="#">Define System Variants</a>	1	
Consumed by	<a href="#">Extract ECU System Timing</a>	1	
Consumed by	<a href="#">Deploy Software Component</a>	0..1	
Use meta model element	SystemTiming	1	

**Table 3.113: System Timing**

### 3.3.2.17 System View Mapping

<b>Artifact</b>	<b>System View Mapping</b>		
<b>Package</b>	AUTOSAR Root::M2::Methodology::Methodology Library::System::Work products		
<b>Brief Description</b>	The System View Mapping provide an mapping between different views on the system.		
<b>Description</b>	This artifact contains a set of system view mappings and provides an mapping between different views on the system, e.g. different overall VFB systems (e.g. abstract system description with system configuration description), or the overall VFB system with the VFB System Extract description.		
<b>Kind</b>	AUTOSAR XML		
<b>Relation Type</b>	<b>Related Element</b>	<b>Mul.</b>	<b>Note</b>
Aggregated by	<a href="#">Overall VFB System</a>	0..1	The Overall VFB System aggregates a potential mapping to the abstract or functional view of the system.
Aggregated by	<a href="#">VFB System Extract</a>	0..1	The VFB System Extract aggregates a potential mapping to the abstract or functional view of the system.
Produced by	<a href="#">Define System View Mapping</a>	1	
Use meta model element	ViewMapSet	1	

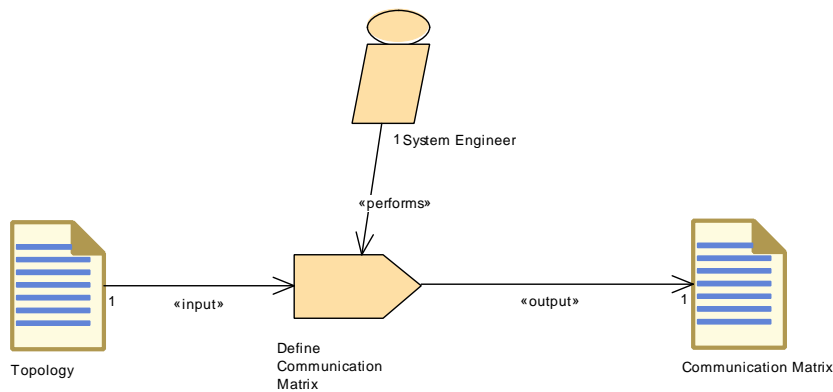
**Table 3.114: System View Mapping**

### 3.3.3 Communication Matrix and Communication Layers

This section contains the tasks and work products to set up the communication matrix and the communication layers as part of a system description.

#### 3.3.3.1 Tasks

##### 3.3.3.1.1 Define Communication Matrix

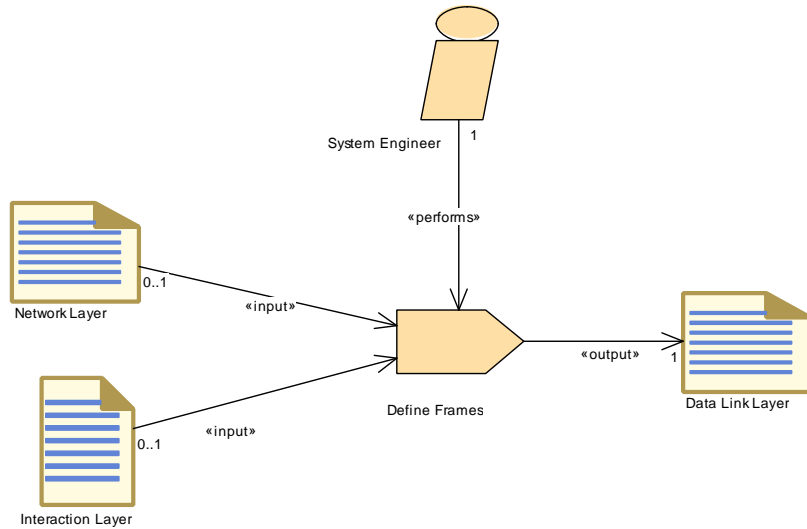


**Figure 3.52: Define Communication Matrix**

<b>Task Definition</b>	<b>Define Communication Matrix</b>		
<b>Package</b>	AUTOSAR Root::M2::Methodology::Methodology Library::System::Communication Matrix::Tasks		
<b>Brief Description</b>	The communication matrix contents are created or extended by adding communication definitions.		
<b>Description</b>	<p>Define or extend Communication Matrix.</p> <p>Define the triggering of the Physical Channels and the mapping to the communication connector ports.</p> <p>In case of extension the original communication matrix contents (which were delivered as part of a system extract) are extended by adding communication definitions. The main use case is the extension of the communication matrix when refining a sub-system.</p>		
<b>Relation Type</b>	<b>Related Element</b>	<b>Mul.</b>	<b>Note</b>
Performed by	<a href="#">System Engineer</a>	1	
Consumes	<a href="#">Topology</a>	1	
Produces	<a href="#">Communication Matrix</a>	1	

**Table 3.115: Define Communication Matrix**

**3.3.3.1.2 Define Frames**

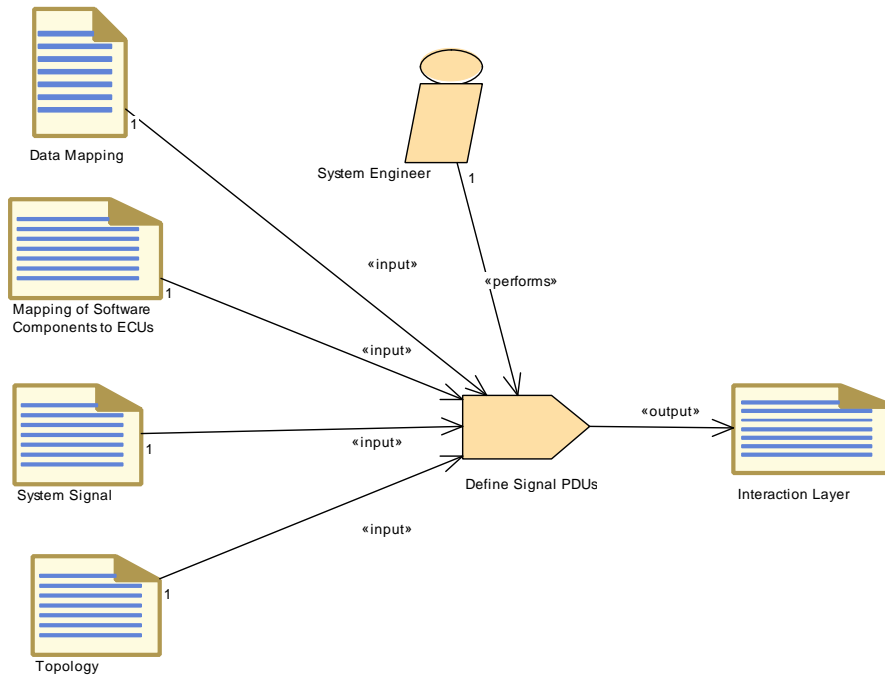


**Figure 3.53: Define Frames**

<b>Task Definition</b>	<b>Define Frames</b>		
<b>Package</b>	AUTOSAR Root::M2::Methodology::Methodology Library::System::Communication Matrix::Tasks		
<b>Brief Description</b>	Define Data Link Layer		
<b>Description</b>	Define the Frame and assign it to a physical channel of a communication cluster. Determine the number, the type, the length and the timing of Frames that are sent or received by the ECUs. Describe the mapping of Pdus (I-Pdus, N-Pdus or NmPdus) into the frame. Define the triggering and the identification of a frame on the physical channel, on which it is sent.		
<b>Relation Type</b>	<b>Related Element</b>	<b>Mul.</b>	<b>Note</b>
Performed by	System Engineer	1	
Consumes	Interaction Layer	0..1	
Consumes	Network Layer	0..1	
Produces	Data Link Layer	1	

**Table 3.116: Define Frames**

**3.3.3.1.3 Define Signal PDUs**

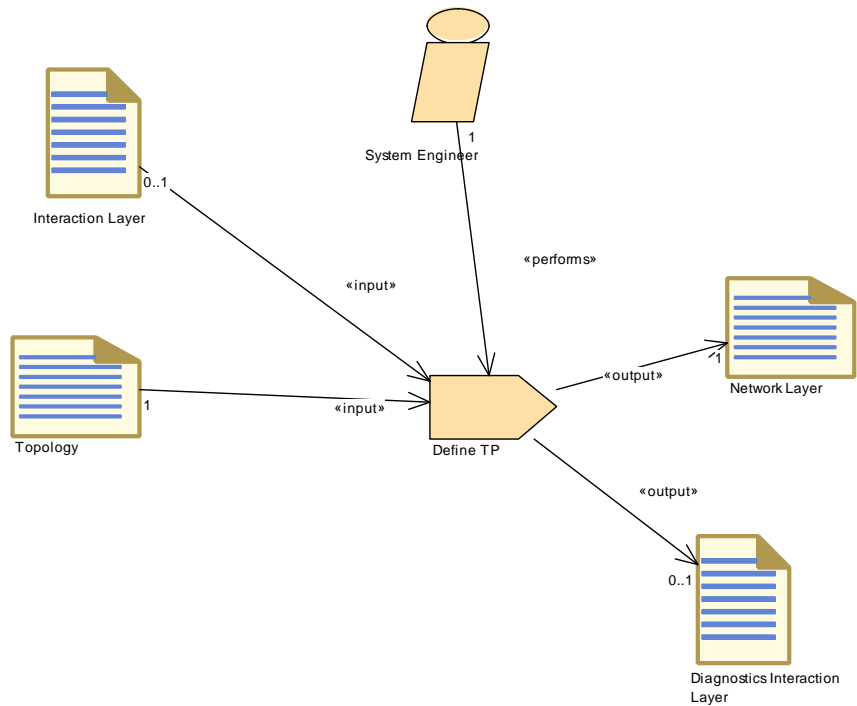


**Figure 3.54: Define Signal PDUs**

<b>Task Definition</b>	<b>Define Signal PDUs</b>		
<b>Package</b>	AUTOSAR Root::M2::Methodology::Methodology Library::System::Communication Matrix::Tasks		
<b>Brief Description</b>	Define the I-PDU and their ISignals		
<b>Description</b>	Define the Signal Pdu that is handled by AUTOSAR COM and assign it to a physical channel of a communication cluster. Determine the length and the timing and describe the mapping of Signals into the Signal Pdu..		
<b>Relation Type</b>	<b>Related Element</b>	<b>Mul.</b>	<b>Note</b>
Performed by	System Engineer	1	
Consumes	Data Mapping	1	
Consumes	Mapping of Software Components to ECUs	1	
Consumes	System Signal	1	
Consumes	Topology	1	
Produces	Interaction Layer	1	ISignals

**Table 3.117: Define Signal PDUs**

**3.3.3.1.4 Define TP**

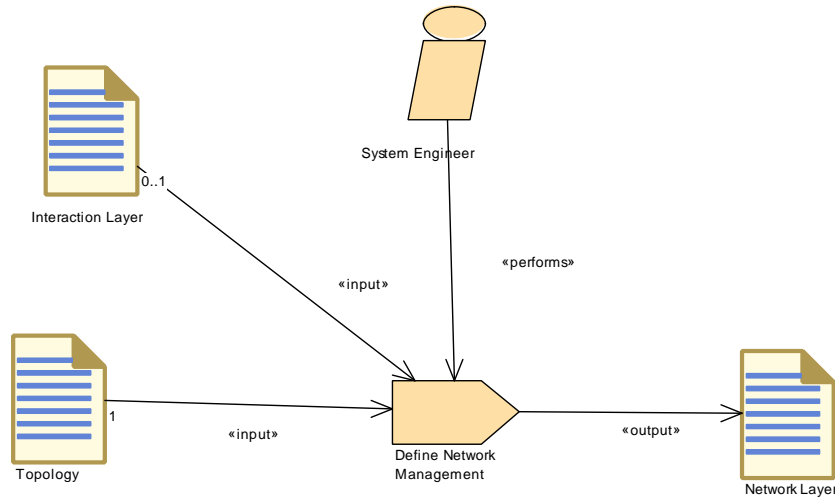


**Figure 3.55: Define TP**

<b>Task Definition</b>	<b>Define TP</b>		
<b>Package</b>	AUTOSAR Root::M2::Methodology::Methodology Library::System::Communication Matrix::Tasks		
<b>Brief Description</b>	Define the Network management and the N-PDUs		
<b>Description</b>	<p>Define the N-PDU - Network Layer Protocol Data Unit (assembled and disassembled in a Transport Protocol module). If an I-PDU does not fit into one frame, a segmentation is needed and will be done through several N-PDUs by the Transport Protocol module.</p> <p>If large COM PDUs are transported by TP, the Interaction Layer should be the Input to the Define TP task. If Diagnostic is used then the Diagnostics Interaction Layer should be an output of Task Define TP.</p>		
<b>Relation Type</b>	<b>Related Element</b>	<b>Mul.</b>	<b>Note</b>
Performed by	System Engineer	1	
Consumes	Topology	1	
Consumes	Interaction Layer	0..1	
Produces	Network Layer	1	
Produces	Diagnostics Interaction Layer	0..1	

**Table 3.118: Define TP**

**3.3.3.1.5 Define Network Management**

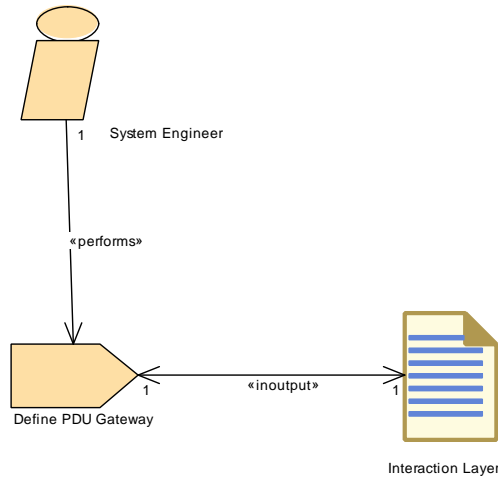


**Figure 3.56: Define Network Management**

<b>Task Definition</b>	<b>Define Network Management</b>		
<b>Package</b>	AUTOSAR Root::M2::Methodology::Methodology Library::System::Communication Matrix::Tasks		
<b>Brief Description</b>			
<b>Description</b>	Define the Network Management that is responsible for the cluster wide coordinated switching of ECUs between operational modes (Network Mode, Bus-sleep Mode). Describe the Nm Pcus and configure the Nm Coordinator, the Nm Clusters and Nm Nodes.		
<b>Relation Type</b>	<b>Related Element</b>	<b>Mul.</b>	<b>Note</b>
Performed by	<a href="#">System Engineer</a>	1	
Consumes	<a href="#">Topology</a>	1	
Consumes	<a href="#">Interaction Layer</a>	0..1	
Produces	<a href="#">Network Layer</a>	1	

**Table 3.119: Define Network Management**

**3.3.3.1.6 Define PDU Gateway**

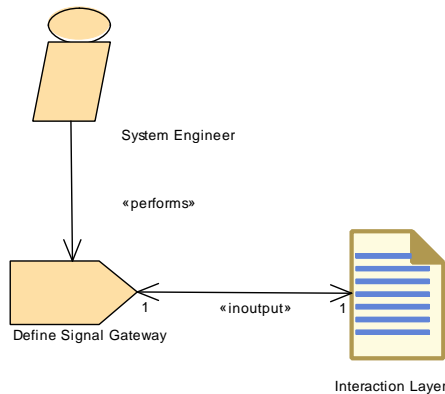


**Figure 3.57: Define PDU Gateway**

<b>Task Definition</b>	<b>Define PDU Gateway</b>		
<b>Package</b>	AUTOSAR Root::M2::Methodology::Methodology Library::System::Communication Matrix::Tasks		
<b>Brief Description</b>	Define the gateway for IPDUs		
<b>Description</b>	Define the gateways that are transferring the I-Pdus from one channel to the other in pairs. Each pair consist of a source and a target referencing to a IPduTriggering. In the case that a Pdu is being gatewayed to more than one channel of the same cluster, all of this gateway relationships shall be specified. Therefore, all affected IpduTriggerings must be described as gateway mappings.		
<b>Relation Type</b>	<b>Related Element</b>	<b>Mul.</b>	<b>Note</b>
Performed by	System Engineer	1	
In/out	Interaction Layer	1	

**Table 3.120: Define PDU Gateway**

**3.3.3.1.7 Define Signal Gateway**

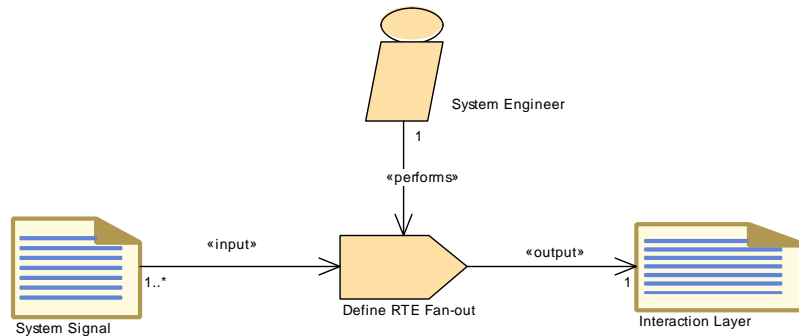


**Figure 3.58: Define Signal Gateway**

<b>Task Definition</b>	<b>Define Signal Gateway</b>		
<b>Package</b>	AUTOSAR Root::M2::Methodology::Methodology Library::System::Communication Matrix::Tasks		
<b>Brief Description</b>			
<b>Description</b>	Define the Signal Gateway to describe the routing of signals and signal groups from one Physical Channel to another Physical Channel.		
<b>Relation Type</b>	<b>Related Element</b>	<b>Mul.</b>	<b>Note</b>
Performed by	System Engineer	1	
In/out	Interaction Layer	1	

**Table 3.121: Define Signal Gateway**

**3.3.3.1.8 Define RTE Fan-out**



**Figure 3.59: Define RTE Fan-out**

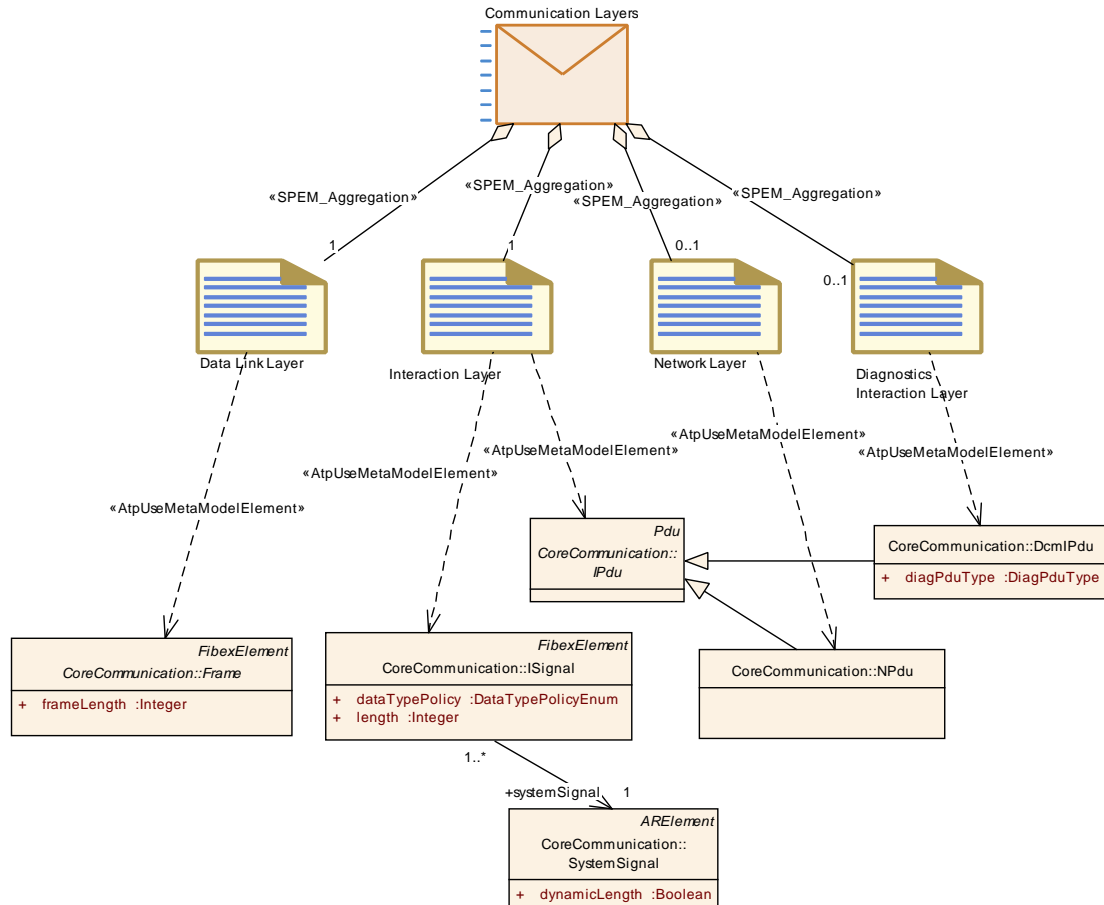
<b>Task Definition</b>	<b>Define RTE Fan-out</b>		
<b>Package</b>	AUTOSAR Root::M2::Methodology::Methodology Library::System::Communication Matrix::Tasks		
<b>Brief Description</b>	Define RTE fan-out which are the relation between ISignals and System Signal		
<b>Description</b>	The RTE supports a "signal fan-out" where the same signal (System Signal) is sent in different IPdus to multiple receivers. The Pdu Router supports the "PDU fan-out" where the same IPdu is sent to multiple destinations.		
<b>Relation Type</b>	<b>Related Element</b>	<b>Mul.</b>	<b>Note</b>
Performed by	System Engineer	1	
Consumes	System Signal	1..*	
Produces	Interaction Layer	1	Link of ISignals to System Signals

**Table 3.122: Define RTE Fan-out**



### 3.3.3.2 Work Products

#### 3.3.3.2.1 Communication Layers



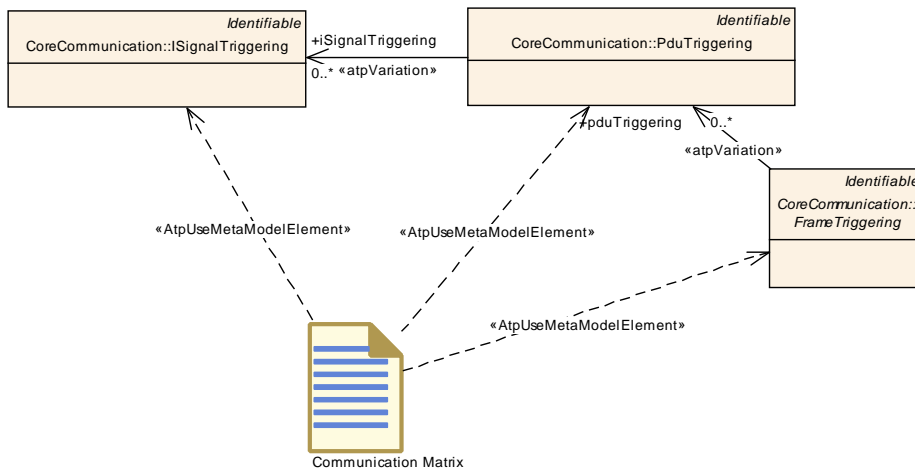
**Figure 3.60: Communication Layers**

<b>Deliverable</b>	<b>Communication Layers</b>		
<b>Package</b>	AUTOSAR Root::M2::Methodology::Methodology Library::System::Communication Matrix::Work products		
<b>Brief Description</b>	Communication Matrix		
<b>Description</b>	It's a container for the description elements of the communication layers		
<b>Kind</b>	Delivered		
<b>Relation Type</b>	<b>Related Element</b>	<b>Mul.</b>	<b>Note</b>
Aggregated by	<a href="#">System Description</a>	0..1	
Aggregates	<a href="#">Data Link Layer</a>	1	
Aggregates	<a href="#">Interaction Layer</a>	1	
Aggregates	<a href="#">Diagnostics Interaction Layer</a>	0..1	
Aggregates	<a href="#">Network Layer</a>	0..1	
Consumed by	<a href="#">Define System Timing</a>	1	

Relation Type	Related Element	Mul.	Note
Consumed by	<a href="#">Extract the ECU Communication</a>	1	
Consumed by	<a href="#">Set System Root</a>	1	Only the reference to the artifact is needed

**Table 3.123: Communication Layers**

**3.3.3.2.2 Communication Matrix**



**Figure 3.61: Communication Matrix**

Artifact	Communication Matrix		
Package	AUTOSAR Root::M2::Methodology::Methodology Library::System::Communication Matrix::Work products		
Brief Description			
Description	<p>Define the mapping of the triggering elements within the Physical Channels to the communication connector ports for the individual ECUs.</p> <p>Because the triggering elements are aggregated as splittable elements within the Physical Channels it is possible to define them in an artifact separated from the Topology.</p>		
Kind	AUTOSAR XML		
Relation Type	Related Element	Mul.	Note
Aggregated by	<a href="#">System Description</a>	0..*	
Produced by	<a href="#">Define Communication Matrix</a>	1	
Use meta model element	FrameTriggering	1	
Use meta model element	ISignalTriggering	1	
Use meta model element	PduTriggering	1	

**Table 3.124: Communication Matrix**

### 3.3.3.2.3 Data Link Layer

<b>Artifact</b>	<b>Data Link Layer</b>		
<b>Package</b>	AUTOSAR Root::M2::Methodology::Methodology Library::System::Communication Matrix::Work products		
<b>Brief Description</b>	Describes the frames that are used in the Data Link Layer		
<b>Description</b>	Describes the layout of frames to be sent over communication channels. This definition belongs to the Data Link Layer. The Data Link Layer provides the functional and procedural means to transfer data between network entities. This layer is used to transmit data passed by an upper layer (PduR, Tp) between adjacent network nodes. In AUTOSAR the Drivers (FrDrv, CanDrv, LinDrv) and Interfaces (FrIf, CanIf, LinIf) belong to the Data Link Layer.		
<b>Kind</b>	AUTOSAR XML		
<b>Relation Type</b>	<b>Related Element</b>	<b>Mul.</b>	<b>Note</b>
Aggregated by	<a href="#">Communication Layers</a>	1	
Produced by	<a href="#">Define Frames</a>	1	
Use meta model element	Frame	1	

**Table 3.125: Data Link Layer**

### 3.3.3.2.4 Interaction Layer

<b>Artifact</b>	<b>Interaction Layer</b>		
<b>Package</b>	AUTOSAR Root::M2::Methodology::Methodology Library::System::Communication Matrix::Work products		
<b>Brief Description</b>	Describes the Signals of the Interaction Layer.		
<b>Description</b>	<p>Describes the Signals of the Interaction Layer. These means describing the Interface between the pre-compile configured RTE and the potentially post-build configured Com Stack.</p> <p>The Interaction Layer provides the application programming interface for COM. It consists of services for the transfer (send and receive operations) of signals. The Interaction Layer packs one or more signals into assigned I-Pdus and passes them to the underlying layer for transfer between nodes in a network.</p> <p>This artifact includes also the mapping definition of ISignals to System Signals.</p>		
<b>Kind</b>	AUTOSAR XML		
<b>Relation Type</b>	<b>Related Element</b>	<b>Mul.</b>	<b>Note</b>
Aggregated by	<a href="#">Communication Layers</a>	1	
Produced by	<a href="#">Define RTE Fan-out</a>	1	Link of ISignals to System Signals
Produced by	<a href="#">Define Signal PDUs</a>	1	ISignals
In/out	<a href="#">Define PDU Gateway</a>	1	

<i>Relation Type</i>	<i>Related Element</i>	<i>Mul.</i>	<i>Note</i>
In/out	<a href="#">Define Signal Gateway</a>	1	
Consumed by	<a href="#">Define Frames</a>	0..1	
Consumed by	<a href="#">Define Network Management</a>	0..1	
Consumed by	<a href="#">Define TP</a>	0..1	
Use meta model element	IPdu	1	
Use meta model element	ISignal	1	

**Table 3.126: Interaction Layer**

### 3.3.3.2.5 Diagnostics Interaction Layer

<i>Artifact</i>	<b>Diagnostics Interaction Layer</b>		
<i>Package</i>	AUTOSAR Root::M2::Methodology::Methodology Library::System::Communication Matrix::Work products		
<i>Brief Description</i>			
<i>Description</i>	Collection of DCM IPDUs.		
<i>Kind</i>	AUTOSAR XML		
<i>Relation Type</i>	<i>Related Element</i>	<i>Mul.</i>	<i>Note</i>
Aggregated by	<a href="#">Communication Layers</a>	0..1	
Produced by	<a href="#">Define TP</a>	0..1	
Use meta model element	DcmIPdu	1	

**Table 3.127: Diagnostics Interaction Layer**

### 3.3.3.2.6 Network Layer

<i>Artifact</i>	<b>Network Layer</b>		
<i>Package</i>	AUTOSAR Root::M2::Methodology::Methodology Library::System::Communication Matrix::Work products		
<i>Brief Description</i>	Describes the PDUs of the Network Layer.		
<i>Description</i>	<p>Describes the PDUs of the Network Layer (N-PDUs and NM-PDUs). The Network Layer's main purposes are :</p> <ul style="list-style-type: none"> <li>• the segmentation and reassembly of I-PDUs and DCM I-PDUs that do not fit in one of the assigned N-PDUs</li> <li>• the definition of NM-PDUs</li> </ul>		
<i>Kind</i>	AUTOSAR XML		
<i>Relation Type</i>	<i>Related Element</i>	<i>Mul.</i>	<i>Note</i>
Aggregated by	<a href="#">Communication Layers</a>	0..1	
Produced by	<a href="#">Define Network Management</a>	1	
Produced by	<a href="#">Define TP</a>	1	

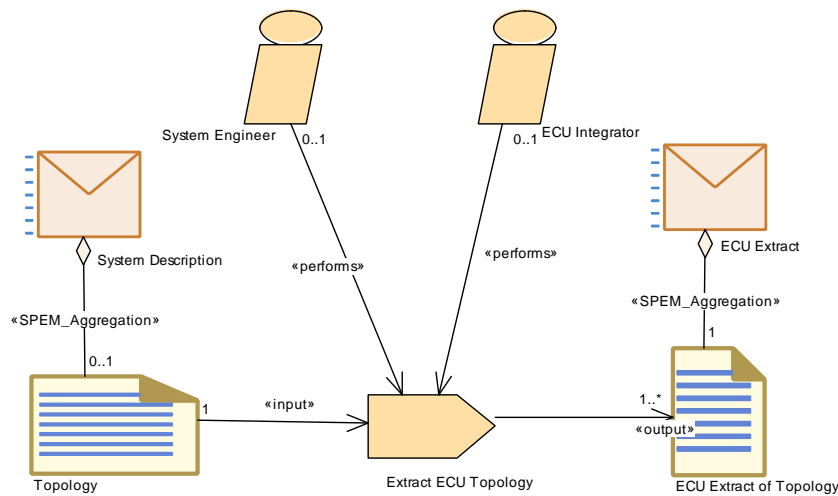
Relation Type	Related Element	Mul.	Note
Consumed by	<a href="#">Define Frames</a>	0..1	
Use meta model element	NPdu	1	

**Table 3.128: Network Layer**

### 3.3.4 ECU Extract

#### 3.3.4.1 Tasks

##### 3.3.4.1.1 Extract ECU Topology

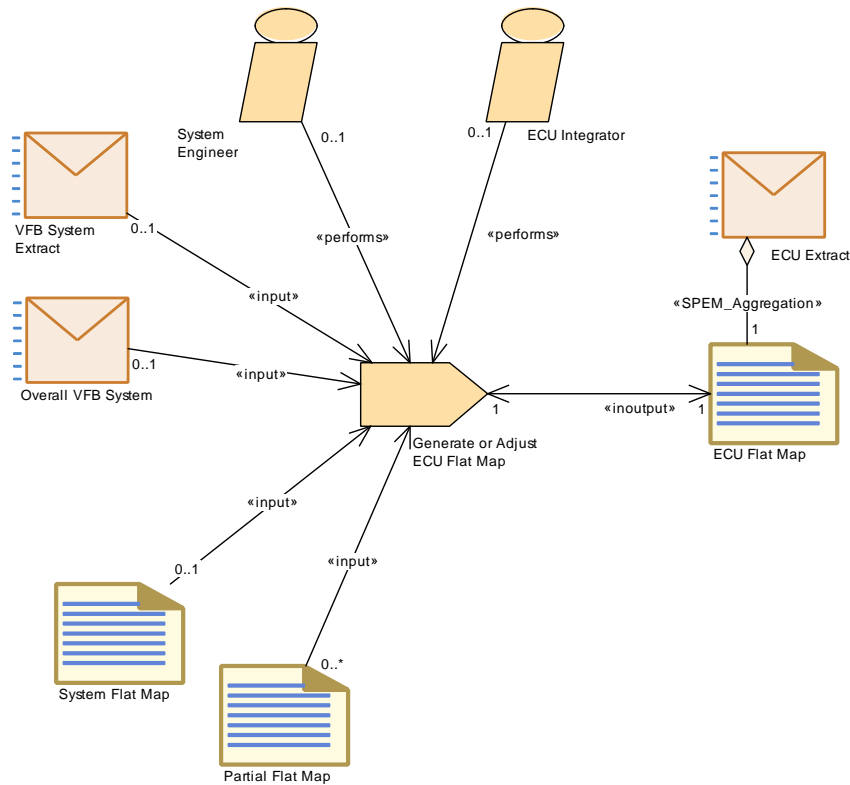


**Figure 3.62: Extract ECU Topology**

Task Definition	Extract ECU Topology		
Package	AUTOSAR Root::M2::Methodology::Methodology Library::System::ECU Extract::Tasks		
Brief Description	Extract the topology for a single ECU from the System Topology		
Description	From the System or System Extract Topology, extract the topology for a single ECU.		
Relation Type	Related Element	Mul.	Note
Performed by	<a href="#">ECU Integrator</a>	0..1	
Performed by	<a href="#">System Engineer</a>	0..1	
Consumes	<a href="#">Topology</a>	1	
Produces	<a href="#">ECU Extract of Topology</a>	1..*	

**Table 3.129: Extract ECU Topology**

**3.3.4.1.2 Generate or Adjust ECU Flat Map**



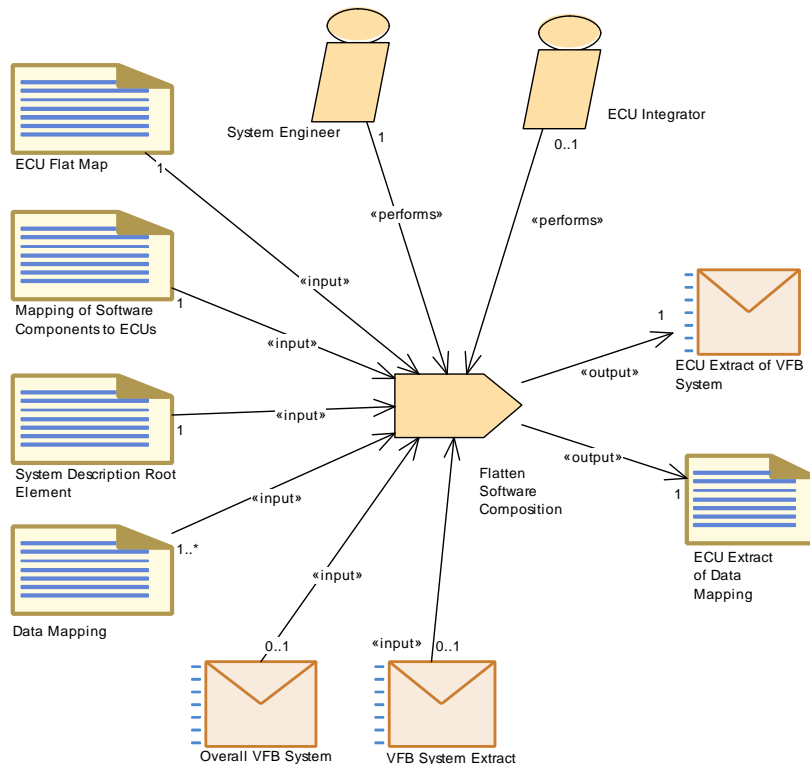
**Figure 3.63: Generate or Adjust ECU Flat Map**

<b>Task Definition</b>	<b>Generate or Adjust ECU Flat Map</b>		
<b>Package</b>	AUTOSAR Root::M2::Methodology::Methodology Library::System::ECU Extract::Tasks		
<b>Brief Description</b>	Generates and/or adjust the unique names of component prototypes and MCD display data in the scope of a single ECU.		
<b>Description</b>	<p>Generates and/or adjust the unique names of component prototypes and MCD display data in the scope of a single ECU. This information is kept in the so-called ECU Flat Map.</p> <p>The names can be generated according to some rules (e.g. from model elements of the VFB system), taken over from the System Flat Map, from partial Flat Maps, or be manually defined. The task shall always result in an ECU Flat Map with unique names.</p>		
<b>Relation Type</b>	<b>Related Element</b>	<b>Mul.</b>	<b>Note</b>
Performed by	ECU Integrator	0..1	
Performed by	System Engineer	0..1	
Consumes	Overall VFB System	0..1	Used to set the upstream references in case one starts from a complete system.
Consumes	System Flat Map	0..1	Take over definitions of unique names from system level to ECU level.
Consumes	VFB System Extract	0..1	Used to set the upstream references in case one starts from a system extract.

Relation Type	Related Element	Mul.	Note
Consumes	Partial Flat Map	0..*	<p>If Partial Flat Maps were delivered along with software components referring only to ECU internal information, they may be integrated into the ECU Flat Map directly, i.e. without needing the System Flat Map.</p> <ul style="list-style-type: none"> <li>The instance refs used in a partial flat map must be taken over and adjusted to the context ECU Extract.</li> <li>Name conflicts have to be resolved if several partial flat maps are merged.</li> </ul>
In/out	ECU Flat Map	1	

**Table 3.130: Generate or Adjust ECU Flat Map**

**3.3.4.1.3 Flatten Software Composition**



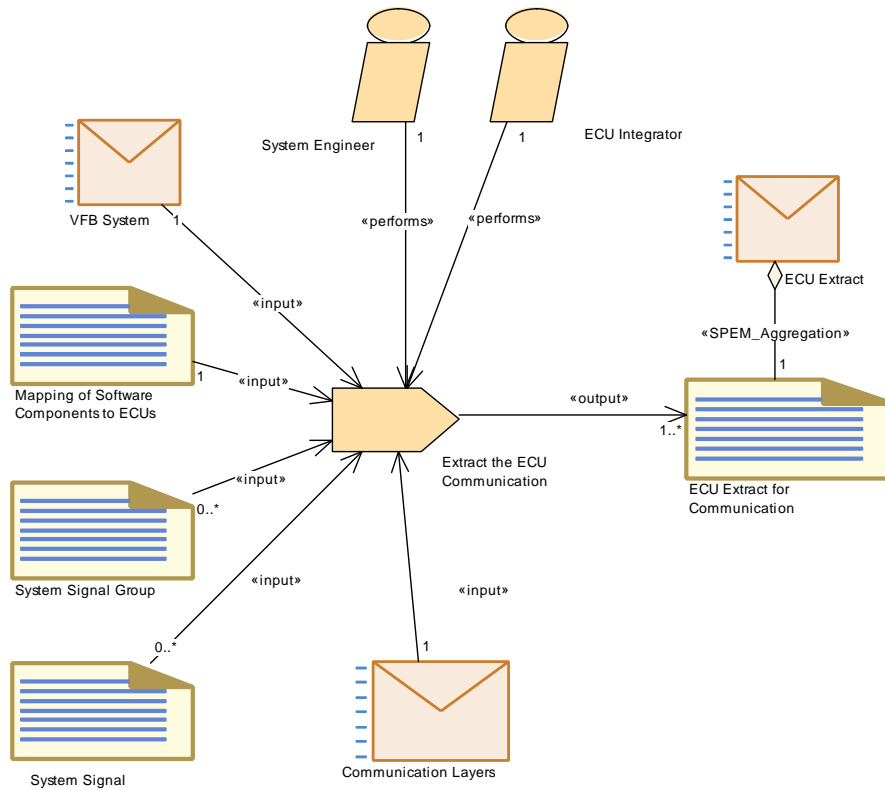
**Figure 3.64: Flatten Software Composition**

<b>Task Definition</b>	<b>Flatten Software Composition</b>		
<b>Package</b>	AUTOSAR Root::M2::Methodology::Methodology Library::System::ECU Extract::Tasks		
<b>Brief Description</b>	Extract and flatten the ECU Software Composition.		
<b>Description</b>	<p>Generate the complete software composition in an ECU by copying ComponentPrototypes from the VFB description into a flat representation (still without service components).</p> <p>Flat representation means, that all compositions are removed and a "flat" set of ComponentPrototypes is generated. Due to the replication of ComponentPrototypes new names have to be generated for those. These can be predefined in the FlatMap which is an input to this task.</p> <p>The ECU Extract of Data Mapping is also created by this task, as the references to the Data Prototypes need to be created with respect to the new component structure.</p>		
<b>Relation Type</b>	<b>Related Element</b>	<b>Mul.</b>	<b>Note</b>
Performed by	System Engineer	1	
Performed by	ECU Integrator	0..1	
Consumes	ECU Flat Map	1	
Consumes	Mapping of Software Components to ECUs	1	
Consumes	System Description Root Element	1	find the top level composition
Consumes	Data Mapping	1..*	
Consumes	Overall VFB System	0..1	Read relevant elements starting from VFB Top Level System Composition in case transformation starts with the full system.
Consumes	VFB System Extract	0..1	Read relevant elements starting from VFB Top Level System Composition in case transformation starts from the system extract.
Produces	ECU Extract of Data Mapping	1	
Produces	ECU Extract of VFB System	1	

**Table 3.131: Flatten Software Composition**



**3.3.4.1.4 Extract the ECU Communication**



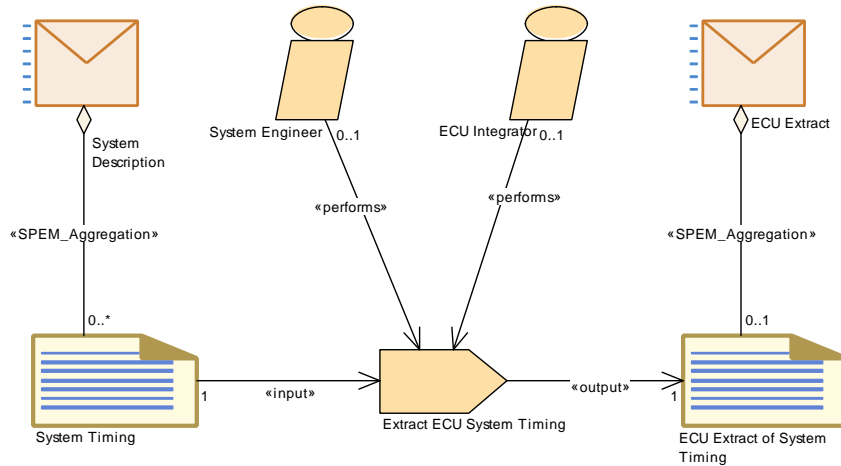
**Figure 3.65: Extract the ECU Communication**

<b>Task Definition</b>	<b>Extract the ECU Communication</b>		
<b>Package</b>	AUTOSAR Root::M2::Methodology::Methodology Library::System::ECU Extract::Tasks		
<b>Brief Description</b>	The limited-scope communication matrices for an ECU to communicate on all networks on which it is directly connected.		
<b>Description</b>	The limited-scope communication matrices for an ECU to communicate on all networks on which it is directly connected.		
<b>Relation Type</b>	<b>Related Element</b>	<b>Mul.</b>	<b>Note</b>
Performed by	ECU Integrator	1	
Performed by	System Engineer	1	
Consumes	Communication Layers	1	
Consumes	Mapping of Software Components to ECUs	1	
Consumes	VFB System	1	Need as input in order to set up the Data Mapping.
Consumes	System Signal	0..*	
Consumes	System Signal Group	0..*	
Produces	ECU Extract for Communication	1..*	

Relation Type	Related Element	Mul.	Note
---------------	-----------------	------	------

**Table 3.132: Extract the ECU Communication**

**3.3.4.1.5 Extract the ECU Timing Model**

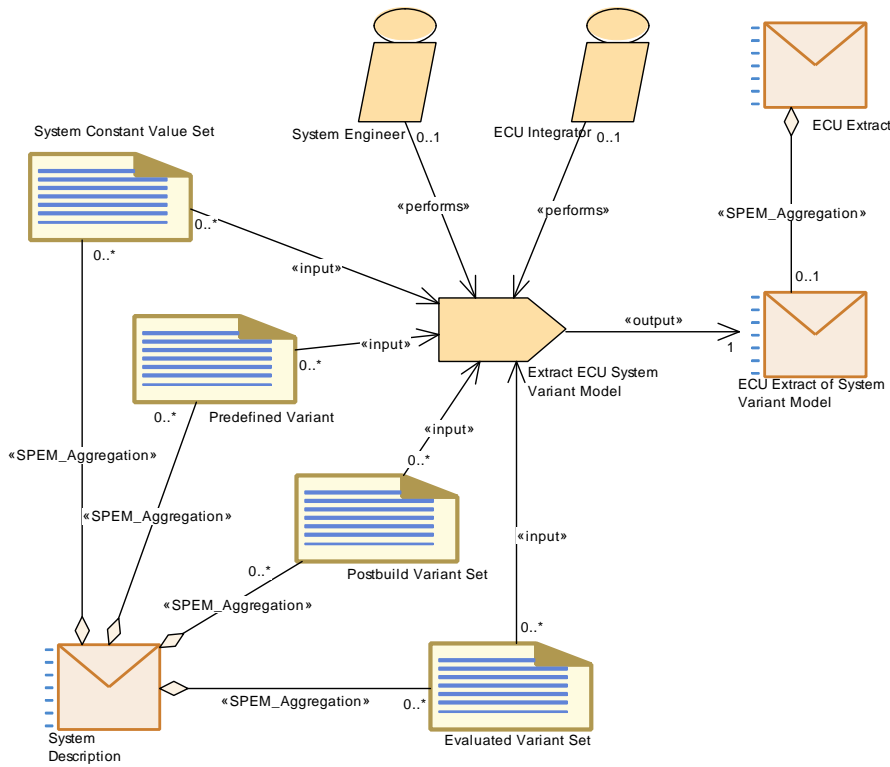


**Figure 3.66: Extract the ECU System Timing Model**

<b>Task Definition</b>	<b>Extract ECU System Timing</b>		
<b>Package</b>	AUTOSAR Root::M2::Methodology::Methodology Library::System::ECU Extract::Tasks		
<b>Brief Description</b>			
<b>Description</b>	Extract the System Timing Model for a particular ECU from the model for a complete system or system extract.		
<b>Relation Type</b>	<b>Related Element</b>	<b>Mul.</b>	<b>Note</b>
Performed by	ECU Integrator	0..1	
Performed by	System Engineer	0..1	
Consumes	System Timing	1	
Produces	ECU Extract of System Timing	1	

**Table 3.133: Extract ECU System Timing**

### 3.3.4.1.6 Extract the ECU System Variant Model



**Figure 3.67: Extract the ECU System Variant Model**

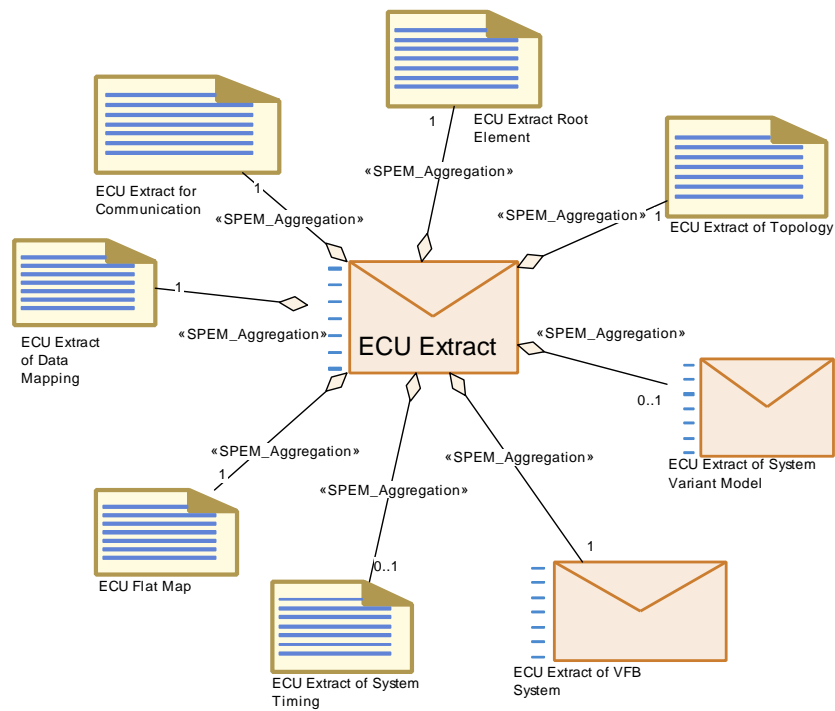
<b>Task Definition</b>	<b>Extract ECU System Variant Model</b>		
<b>Package</b>	AUTOSAR Root::M2::Methodology::Methodology Library::System::ECU Extract::Tasks		
<b>Brief Description</b>			
<b>Description</b>	<p>Extract the global model elements (ARElements) that are used to describe variants from system or system extract scope to a particular ECU scope. This applies to:</p> <ul style="list-style-type: none"> <li>• System Constant Value Set</li> <li>• Postbuild Variant Set</li> <li>• Predefined Variant</li> <li>• Evaluated Variant Set</li> </ul> <p>They are transformed as far as they are needed into the ECU Extract.</p>		
<b>Relation Type</b>	<b>Related Element</b>	<b>Mul.</b>	<b>Note</b>
Performed by	ECU Integrator	0..1	
Performed by	System Engineer	0..1	
Consumes	Evaluated Variant Set	0..*	
Consumes	Postbuild Variant Set	0..*	
Consumes	Predefined Variant	0..*	

Relation Type	Related Element	Mul.	Note
Consumes	System Constant Value Set	0..*	
Produces	ECU Extract of System Variant Model	1	

**Table 3.134: Extract ECU System Variant Model**

### 3.3.4.2 Work Products

#### 3.3.4.2.1 ECU Extract



**Figure 3.68: ECU Extract**

<b>Deliverable</b>	<b>ECU Extract</b>		
<b>Package</b>	AUTOSAR Root::M2::Methodology::Methodology Library::System::ECU Extract::Work products		
<b>Brief Description</b>	A version of the System Description, with information pertaining to a single ECU.		
<b>Description</b>	<p>A deliverable used to describe the ECU specific view on the System Description. The ECU Extract is fully decomposed and contains only Atomic Software Components. It is the basis for setting up the ECU Configuration.</p> <p>A timing model is optionally included.</p> <p>This deliverable may contain variation points in its XML artifacts which need to be bound for the ECU. If such variation points are present, the ECU extract may optionally include Predefined Variants in order to predefine variants for later selection and an Evaluated Variant Set (this is expressed by artifact ECU Extract of System Variant Model).</p> <p>This deliverable corresponds to the system description with the system category "ECU_EXTRACT" (see [TPS_SYST_01003]).</p>		
<b>Kind</b>	Delivered		
<b>Relation Type</b>	<b>Related Element</b>	<b>Mul.</b>	<b>Note</b>
Aggregates	<a href="#">ECU Extract Root Element</a>	1	
Aggregates	<a href="#">ECU Extract for Communication</a>	1	
Aggregates	<a href="#">ECU Extract of Data Mapping</a>	1	
Aggregates	<a href="#">ECU Extract of Topology</a>	1	
Aggregates	<a href="#">ECU Extract of VF B System</a>	1	
Aggregates	<a href="#">ECU Flat Map</a>	1	
Aggregates	<a href="#">ECU Extract of System Timing</a>	0..1	
Aggregates	<a href="#">ECU Extract of System Variant Model</a>	0..1	
Produced by	<a href="#">Generate ECU Extract</a>	1	
Produced by	<a href="#">Develop Sub-System</a>	1..*	
Produced by	<a href="#">Develop System</a>	1..*	
Consumed by	<a href="#">Configure Com</a>	1	
Consumed by	<a href="#">Configure Debug</a>	1	
Consumed by	<a href="#">Configure Diagnostics</a>	1	Application software requirements for diagnostics, especially SwcServiceDependency and ServiceNeeds.
Consumed by	<a href="#">Configure ECUC</a>	1	

<b>Relation Type</b>	<b>Related Element</b>	<b>Mul.</b>	<b>Note</b>
Consumed by	Configure Mode Management	1	Application software requirements for NvM, especially SwcServiceDependency and ServiceNeeds.
Consumed by	Configure NvM	1	Application software requirements for NvM, especially SwcServiceDependency and ServiceNeeds.
Consumed by	Configure RTE	1	Elements of the System Description and VFB Description are referred by the RTE configuration.  Optional Input: ECU Extract of System Timing, e.g. execution order constraints.
Consumed by	Configure Watch-dog Manager	1	Application software requirements for WdgM, especially SwcServiceDependency and ServiceNeeds.
Consumed by	Connect Service Component	1	Find the ports on the application side to be connected to the Service Component.
Consumed by	Define Integration Variant	1	
Consumed by	Generate Base Ecu Configuration	1	
Consumed by	Generate RTE	1	Find the VFB description of all Atomic Software Components on this ECU and the relevant parts of the system description.  The ECU Flat Map is also an input. Meth.bindingTime = SystemDesignTime
Consumed by	Generate RTE Postbuild Dataset	1	Meth.bindingTime = LinkTime
Consumed by	Generate RTE Prebuild Dataset	1	Meth.bindingTime = CodeGenerationTime
Consumed by	Integrate Software for ECU	1	
Consumed by	Prepare ECU Configuration	1	
Consumed by	Create MC Function Model	0..1	The ECU Flat Map can be used to define references to variables and parameters which are later visible in A2L.  Furthermore, the ECU Extract can be used to find the relevant software components.
Consumed by	Create Service Component	0..1	Input information about the Service Ports and Service Dependencies of the software components.
Consumed by	Define ECU Timing	0..1	Needed to set up links to the elements of the ECU extract.

**Table 3.135: ECU Extract**

### 3.3.4.2.2 ECU Extract Root Element

<b>Artifact</b>	<b>ECU Extract Root Element</b>		
<b>Package</b>	AUTOSAR Root::M2::Methodology::Methodology Library::System::ECU Extract::Work products		
<b>Brief Description</b>			
<b>Description</b>	Extract of the System root element for a specific ECU.		
<b>Kind</b>	AUTOSAR XML		
<b>Extends</b>	System		
<b>Relation Type</b>	<b>Related Element</b>	<b>Mul.</b>	<b>Note</b>
Aggregated by	<a href="#">ECU Extract</a>	1	
Use meta model element	System	1	

**Table 3.136: ECU Extract Root Element**

### 3.3.4.2.3 ECU Extract of VFB System

<b>Deliverable</b>	<b>ECU Extract of VFB System</b>		
<b>Package</b>	AUTOSAR Root::M2::Methodology::Methodology Library::System::ECU Extract::Work products		
<b>Brief Description</b>	Contains the complete software composition in an ECU, copied from the VFB description into a flat representation, it is still without service components.		
<b>Description</b>	Contains the complete software composition in an ECU, copied from the VFB description into a flat representation, that means it is still without service components. Flat representation means, that all compositions have been removed and a "flat" set of ComponentPrototypes was generated (including their connectors) which are put into the top level composition of the ECU.		
<b>Kind</b>	Delivered		
<b>Extends</b>	<a href="#">VFB System</a>		
<b>Relation Type</b>	<b>Related Element</b>	<b>Mul.</b>	<b>Note</b>
Aggregated by	<a href="#">ECU Extract</a>	1	
Produced by	<a href="#">Flatten Software Composition</a>	1	
Use meta model element	RootSwCompositionPrototype	1	

**Table 3.137: ECU Extract of VFB System**

### 3.3.4.2.4 ECU Extract of Data Mapping

<b>Artifact</b>	<b>ECU Extract of Data Mapping</b>		
<b>Package</b>	AUTOSAR Root::M2::Methodology::Methodology Library::System::ECU Extract::Work products		
<b>Brief Description</b>			
<b>Description</b>	ECU extract of the mapping of data prototypes from the (flattened) VFB description to System Signals.		
<b>Kind</b>	AUTOSAR XML		
<b>Relation Type</b>	<b>Related Element</b>	<b>Mul.</b>	<b>Note</b>
Aggregated by	<a href="#">ECU Extract</a>	1	
Produced by	<a href="#">Flatten Software Composition</a>	1	
Use meta model element	DataMapping	1	

**Table 3.138: ECU Extract of Data Mapping**

### 3.3.4.2.5 ECU Extract of Topology

<b>Artifact</b>	<b>ECU Extract of Topology</b>		
<b>Package</b>	AUTOSAR Root::M2::Methodology::Methodology Library::System::ECU Extract::Work products		
<b>Brief Description</b>	A view of the topology centered around a single ECU.		
<b>Description</b>	A view of the topology centered around a single ECU.		
<b>Kind</b>	AUTOSAR XML		
<b>Relation Type</b>	<b>Related Element</b>	<b>Mul.</b>	<b>Note</b>
Aggregated by	<a href="#">ECU Extract</a>	1	
Produced by	<a href="#">Extract ECU Topology</a>	1..*	
Use meta model element	Communication Cluster	1	
Use meta model element	EcuInstance	1	

**Table 3.139: ECU Extract of Topology**

### 3.3.4.2.6 ECU Extract for Communication



<b>Artifact</b>	<b>ECU Extract for Communication</b>		
<b>Package</b>	AUTOSAR Root::M2::Methodology::Methodology Library::System::ECU Extract::Work products		
<b>Brief Description</b>	A version of the System Communication Matrix work product, with information pertaining to a single ECU.		
<b>Description</b>	<p>This artifact represents an extract of the System Description elements for communication with respect to a single ECU. It provides all information needed to let the ECU communicate on all networks on which it is directly connected.</p> <p>It is extracted from these system artifacts:</p> <ul style="list-style-type: none"> <li>• Communication Matrix</li> <li>• Communication Layers</li> <li>• System Signal(s)</li> <li>• System Signal Group(s)</li> </ul>		
<b>Kind</b>	AUTOSAR XML		
<b>Relation Type</b>	<b>Related Element</b>	<b>Mul.</b>	<b>Note</b>
Aggregated by	<a href="#">ECU Extract</a>	1	
Produced by	<a href="#">Extract the ECU Communication</a>	1..*	
Use meta model element	FibexElement	1	

**Table 3.140: ECU Extract for Communication**

### 3.3.4.2.7 ECU Extract of System Timing

<b>Artifact</b>	<b>ECU Extract of System Timing</b>		
<b>Package</b>	AUTOSAR Root::M2::Methodology::Methodology Library::System::ECU Extract::Work products		
<b>Brief Description</b>			
<b>Description</b>	The extract of the System Timing for a particular ECU.		
<b>Kind</b>	AUTOSAR XML		
<b>Relation Type</b>	<b>Related Element</b>	<b>Mul.</b>	<b>Note</b>
Aggregated by	<a href="#">ECU Extract</a>	0..1	
Produced by	<a href="#">Extract ECU System Timing</a>	1	
Consumed by	<a href="#">Define ECU Timing</a>	0..1	
Use meta model element	SystemTiming	1	

**Table 3.141: ECU Extract of System Timing**

### 3.3.4.2.8 ECU Extract of System Variant Model

<b>Deliverable</b>	<b>ECU Extract of System Variant Model</b>		
<b>Package</b>	AUTOSAR Root::M2::Methodology::Methodology Library::System::ECU Extract::Work products		
<b>Brief Description</b>			
<b>Description</b>	<p>An extract of the System artifacts</p> <ul style="list-style-type: none"> <li>• System Constant Value Set</li> <li>• Postbuild Variant Set</li> <li>• Predefined Variant</li> <li>• Evaluated Variant Set</li> </ul> <p>It contains only the elements relevant for a particular ECU.</p>		
<b>Kind</b>	Delivered		
<b>Relation Type</b>	<b>Related Element</b>	<b>Mul.</b>	<b>Note</b>
Aggregated by	<a href="#">ECU Extract</a>	0..1	
Aggregates	<a href="#">Evaluated Variant Set</a>	0..*	
Aggregates	<a href="#">Postbuild Variant Set</a>	0..*	
Aggregates	<a href="#">Predefined Variant</a>	0..*	
Aggregates	<a href="#">System Constant Value Set</a>	0..*	
Produced by	<a href="#">Extract ECU System Variant Model</a>	1	

**Table 3.142: ECU Extract of System Variant Model**

### 3.3.4.2.9 ECU Flat Map

<b>Artifact</b>	<b>ECU Flat Map</b>		
<b>Package</b>	AUTOSAR Root::M2::Methodology::Methodology Library::System::ECU Extract::Work products		
<b>Brief Description</b>	Mapping of instance names to nested model elements. Use cases: Resolve name conflicts when flattening VFB software compositions; provide unique names for measurement and calibration data.		
<b>Description</b>	<p>The flat map is a list of elements, each element represents exactly one node (e.g. a component instance or data element) of the instance tree of a software system. The purpose of this element is to map the various nested representations of this instance to a flat representation and assign a unique name to it. The name will be unique in the scope of a single ECU. (Note that additional alias names can be defined via artifact Alias Name Set.)</p> <p>Use cases:</p> <ul style="list-style-type: none"> <li>• Specify the display name of a data object for measurement and calibration. This serves as an input for the calibration support which is produced by the RTE generator. The RTE generator needs to find the attributes assigned to these data via the attached references.</li> <li>• Specify a unique name for an instance of a component prototype in the ECU extract of the system description. This information is needed to set up the ECU extract.</li> <li>• Assign initial values to calibration parameters as input for the RTE generator.</li> </ul>		
<b>Kind</b>	AUTOSAR XML		
<b>Relation Type</b>	<b>Related Element</b>	<b>Mul.</b>	<b>Note</b>
Aggregated by	<a href="#">ECU Extract</a>	1	
In/out	<a href="#">Generate or Adjust ECU Flat Map</a>	1	
Consumed by	<a href="#">Flatten Software Composition</a>	1	
Consumed by	<a href="#">Generate Local MC Data Support</a>	1	Meth.bindingTime = SystemDesignTime
Consumed by	<a href="#">Provide RTE Calibration Dataset</a>	1	
Consumed by	<a href="#">Generate A2L</a>	0..1	The ECU Flat Map is needed in case the A2L generator has to process an MC Function Model that relates to data in the ECU Flat Map.
Use meta model element	FlatInstanceDescriptor	1	

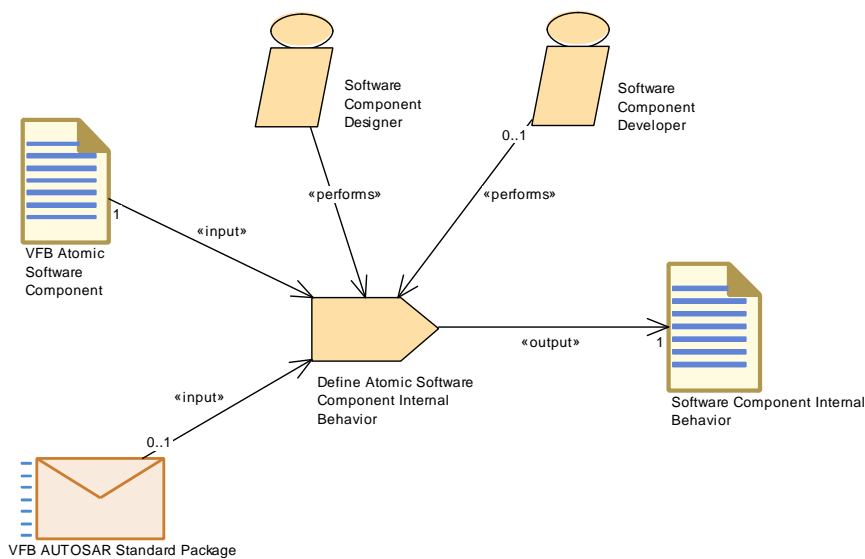
**Table 3.143: ECU Flat Map**

### 3.4 Software Component

This chapter contains the definition of work products and tasks used for the development of a single software component against a given VFB description. For the definition of the relevant meta-model elements refer to [4].

#### 3.4.1 Tasks

##### 3.4.1.1 Define Software Component Internal Behavior



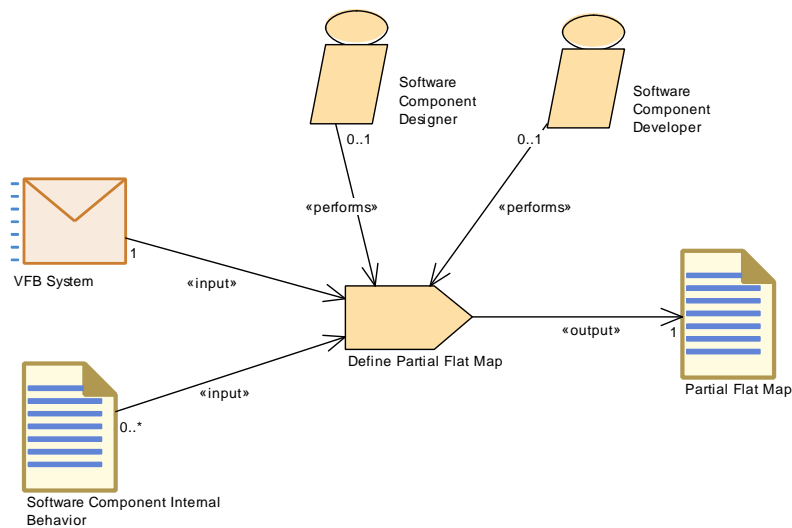
**Figure 3.69: Define Software Component Internal Behavior**

<b>Task Definition</b>	<b>Define Atomic Software Component Internal Behavior</b>		
<b>Package</b>	AUTOSAR Root::M2::Methodology::Methodology Library::Component::Tasks		
<b>Brief Description</b>	Define the InternalBehavior in relation to a given AtomicSoftwareComponentType		
<b>Description</b>	Define the InternalBehavior in relation to a given AtomicSoftwareComponentType so that an RTE API can be generated. This includes the definition of Runnables, RTE Events, Inter-Runnable variables, etc.		
<b>Relation Type</b>	<b>Related Element</b>	<b>Mul.</b>	<b>Note</b>
Performed by	Software Component Designer	1	
Performed by	Software Component Developer	0..1	
Consumes	VFB Atomic Software Component	1	
Consumes	VFB AUTOSAR Standard Package	0..1	Use standardized elements (e.g. Data Types) as blueprints (as far as applicable) to create the corresponding elements of the actual project.

Relation Type	Related Element	Mul.	Note
Produces	Software Component Internal Behavior	1	

**Table 3.144: Define Atomic Software Component Internal Behavior**

### 3.4.1.2 Define Partial Flat Map



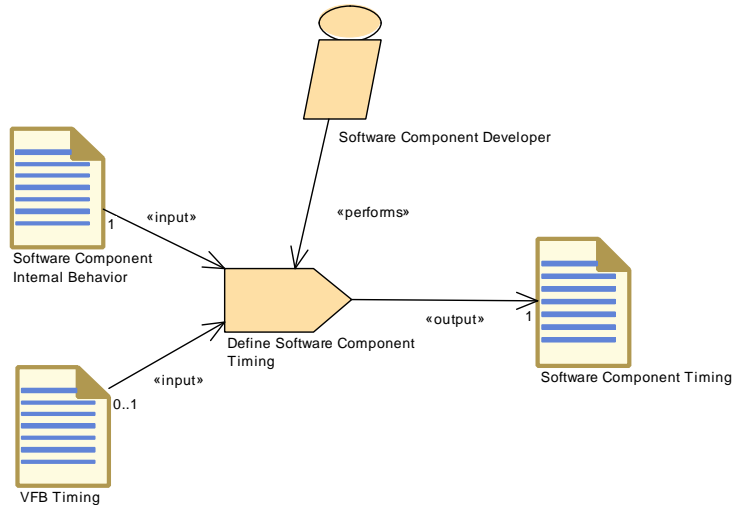
**Figure 3.70: Define Partial Flat Map**

Task Definition	Define Partial Flat Map		
Package	AUTOSAR Root::M2::Methodology::Methodology Library::Component::Tasks		
Brief Description			
Description	Define a Partial Flat Map for an intended delivery of Atomic Software Components.		
Relation Type	Related Element	Mul.	Note
Performed by	Software Component Designer	0..1	
Performed by	Software Component Developer	0..1	

Relation Type	Related Element	Mul.	Note
Consumes	VFB System	1	Various parts of a given VFB system will be used as input: <ul style="list-style-type: none"> <li>• Refer to parameters and variables in port interfaces and their data types.</li> <li>• In order to define unique names, also other the component definitions not in the scope of the partial flat map might be checked.</li> <li>• Set a link to the context of the Flat Map, e.g. a VFB Composition.</li> </ul>
Consumes	Software Component Internal Behavior	0..*	Refer to parameter and variables defined in the Internal Behavior of one or more Atomic Software Components.
Produces	Partial Flat Map	1	

**Table 3.145: Define Partial Flat Map**

### 3.4.1.3 Define Software Component Timing

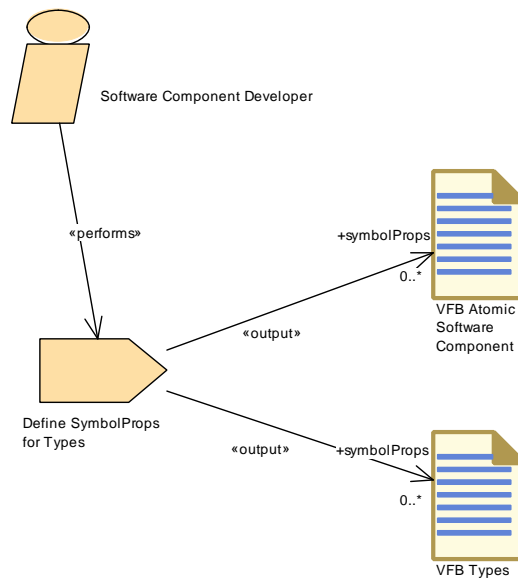


**Figure 3.71: Define Software Component Timing**

<b>Task Definition</b>	<b>Define Software Component Timing</b>		
<b>Package</b>	AUTOSAR Root::M2::Methodology::Methodology Library::Component::Tasks		
<b>Brief Description</b>	Define SWCTiming (TimingDescription and TimingConstraints) for the Internal Behavior (RunnableEntities) of a Software Component		
<b>Description</b>	<p>Define SWCTiming (TimingDescription and TimingConstraints) of a software component. A software component can either be of type AtomicSWComponentType or CompositionSWComponentType.</p> <p>In the former case, the task allows to describe timing description and constraints for the InternalBehavior of the AtomicSWComponentType.</p> <p>In the latter case, timing descriptions and constraints can be defined for all Atomic Software Components in the CompositionSWComponentType.</p>		
<b>Relation Type</b>	<b>Related Element</b>	<b>Mul.</b>	<b>Note</b>
Performed by	Software Component Developer	1	
Consumes	Software Component Internal Behavior	1	
Consumes	VFB Timing	0..1	
Produces	Software Component Timing	1	

**Table 3.146: Define Software Component Timing**

**3.4.1.4 Define SymbolProps for Types**



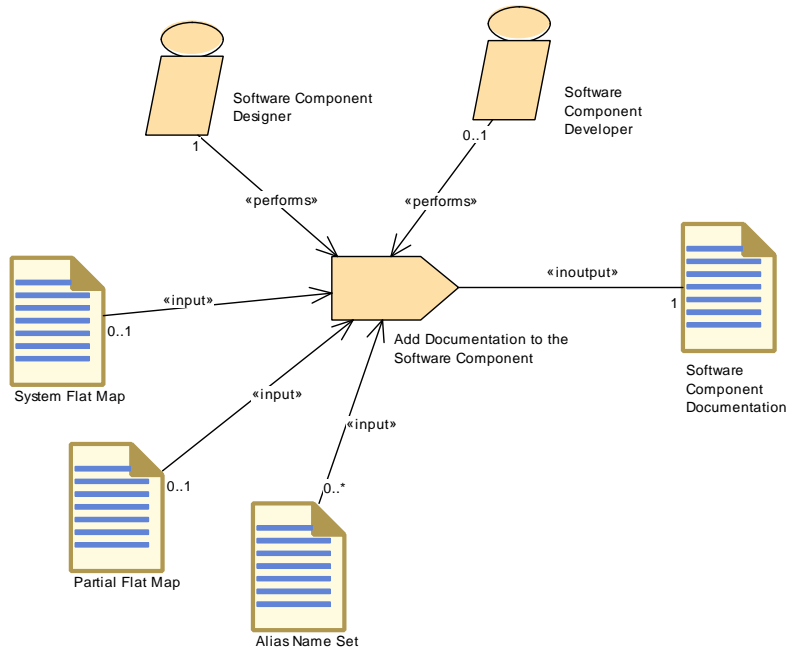
**Figure 3.72: Define SymbolProps for Types**

<b>Task Definition</b>	<b>Define SymbolProps for Types</b>		
<b>Package</b>	AUTOSAR Root::M2::Methodology::Methodology Library::Component::Tasks		
<b>Brief Description</b>	Define SymbolProps for types in order to resolve name conflicts in the code.		
<b>Description</b>	<p>Redefines the symbols used by the RTE contract for the names of software component types and/or implementation data types (in the code as well as in certain header file names).</p> <p>This task is used to resolve name conflicts between different software components without changing the VFB model.</p>		
<b>Relation Type</b>	<b>Related Element</b>	<b>Mul.</b>	<b>Note</b>
Performed by	<a href="#">Software Component Developer</a>	1	
Produces	<a href="#">VFB Atomic Software Component</a>	0..*	<p>symbolProps: The symbolProps attribute redefines the software component type name used in the code of the RTE. This resolves name clashes among different software component types designed accidentally with the same shortName.</p> <p>Note that this output is a splitable element, so it can be added later without changing the VFB model.</p>
Produces	<a href="#">VFB Types</a>	0..*	<p>symbolProps: The symbolProps attribute redefines the implementation data type name used in the code of the RTE and/or the component. This resolves name clashes among different implementation data types designed accidentally with the same shortName.</p> <p>Note that this output is a splitable element, so it can be added later without changing the VFB model.</p>

**Table 3.147: Define SymbolProps for Types**



### 3.4.1.5 Add Documentation to the Software Component

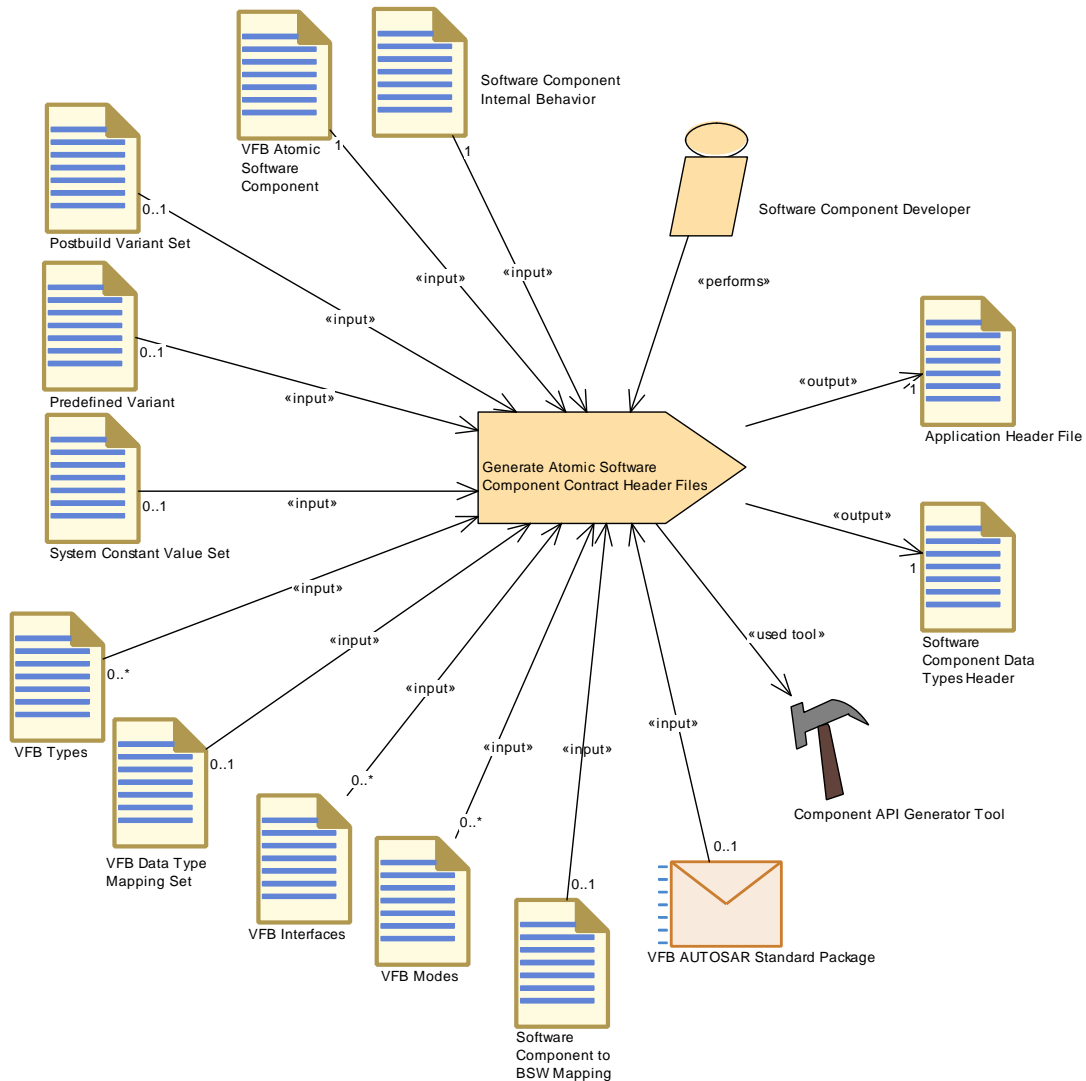


**Figure 3.73: Add Documentation to the Software Component**

<b>Task Definition</b>	<b>Add Documentation to the Software Component</b>		
<b>Package</b>	AUTOSAR Root::M2::Methodology::Methodology Library::Component::Tasks		
<b>Brief Description</b>	Add documentation to the Software Component		
<b>Description</b>	Add documentation to the Software Component describing the functionality, how to test it, the calibration uses, the maintenance and diagnosis issues.		
<b>Relation Type</b>	<b>Related Element</b>	<b>Mul.</b>	<b>Note</b>
Performed by	<a href="#">Software Component Designer</a>	1	
Performed by	<a href="#">Software Component Developer</a>	0..1	
Consumes	<a href="#">Partial Flat Map</a>	0..1	Optional input in order to refer to unique names defined in component or composition context.
Consumes	<a href="#">System Flat Map</a>	0..1	Optional input in order to refer to unique names defined in system context.
Consumes	<a href="#">Alias Name Set</a>	0..*	Optional input in order to refer to unique names defined in an Alias Name Set (e.g. System Constants).
In/out	<a href="#">Software Component Documentation</a>	1	

**Table 3.148: Add Documentation to the Software Component**

### 3.4.1.6 Generate Atomic Software Component Contract Header Files



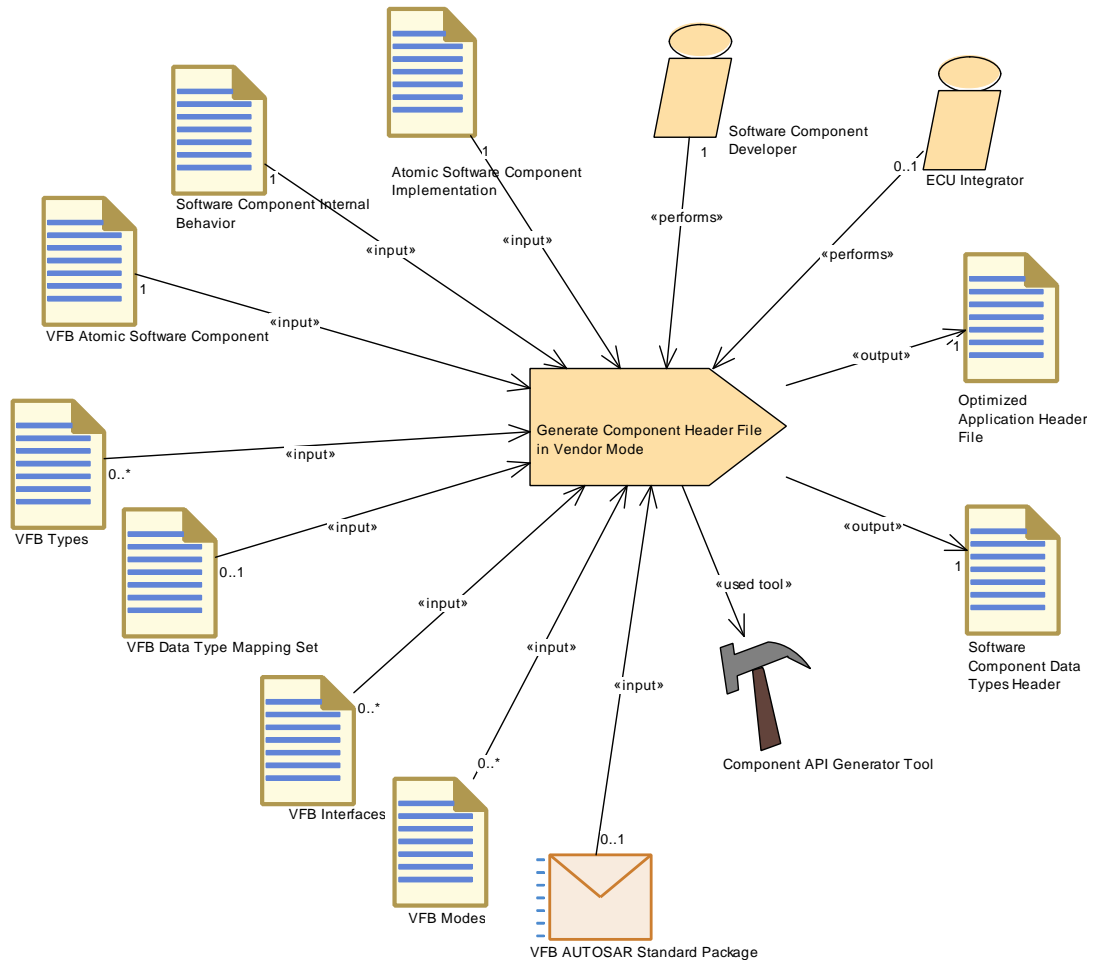
**Figure 3.74: Generate Atomic Software Component Contract Header Files**

<b>Task Definition</b>	<b>Generate Atomic Software Component Contract Header Files</b>		
<b>Package</b>	AUTOSAR Root::M2::Methodology::Methodology Library::Component::Tasks		
<b>Brief Description</b>	Generate the component contract header files.		
<b>Description</b>	<p>Generate the component header files as part of the so-called "contract phase". These headers will allow to link the component later on with the RTE.</p> <p>The header can still contain variants with later binding time, therefore the information about these variants is contained in the input to this task.</p> <p>Meth.bindingTime = CodeGenerationTime</p>		
<b>Relation Type</b>	<b>Related Element</b>	<b>Mul.</b>	<b>Note</b>

<b>Relation Type</b>	<b>Related Element</b>	<b>Mul.</b>	<b>Note</b>
Performed by	Software Component Developer	1	
Consumes	Software Component Internal Behavior	1	Meth.bindingTime = SystemDesignTime
Consumes	VFB Atomic Software Component	1	Meth.bindingTime = SystemDesignTime
Consumes	Postbuild Variant Set	0..1	
Consumes	Predefined Variant	0..1	
Consumes	Software Component to BSW Mapping	0..1	If a Software Component is mapped to a BSW module description, this input is optionally needed already in the contract phase in order to ensure that the generated prototypes for runnables are consistent with the definitions in Software Component and BSW. Meth.bindingTime = SystemDesignTime
Consumes	System Constant Value Set	0..1	Meth.bindingTime = SystemDesignTime
Consumes	VFB AUTOSAR Standard Package	0..1	
Consumes	VFB Data Type Mapping Set	0..1	Meth.bindingTime = SystemDesignTime
Consumes	VFB Interfaces	0..*	Meth.bindingTime = SystemDesignTime
Consumes	VFB Modes	0..*	Meth.bindingTime = SystemDesignTime
Consumes	VFB Types	0..*	Meth.bindingTime = SystemDesignTime
Produces	Application Header File	1	Meth.bindingTime = CodeGenerationTime
Produces	Software Component Data Types Header	1	Meth.bindingTime = CodeGenerationTime
Used tool	Component API Generator Tool	1	

**Table 3.149: Generate Atomic Software Component Contract Header Files**

### 3.4.1.7 Generate Component Header File in Vendor Mode



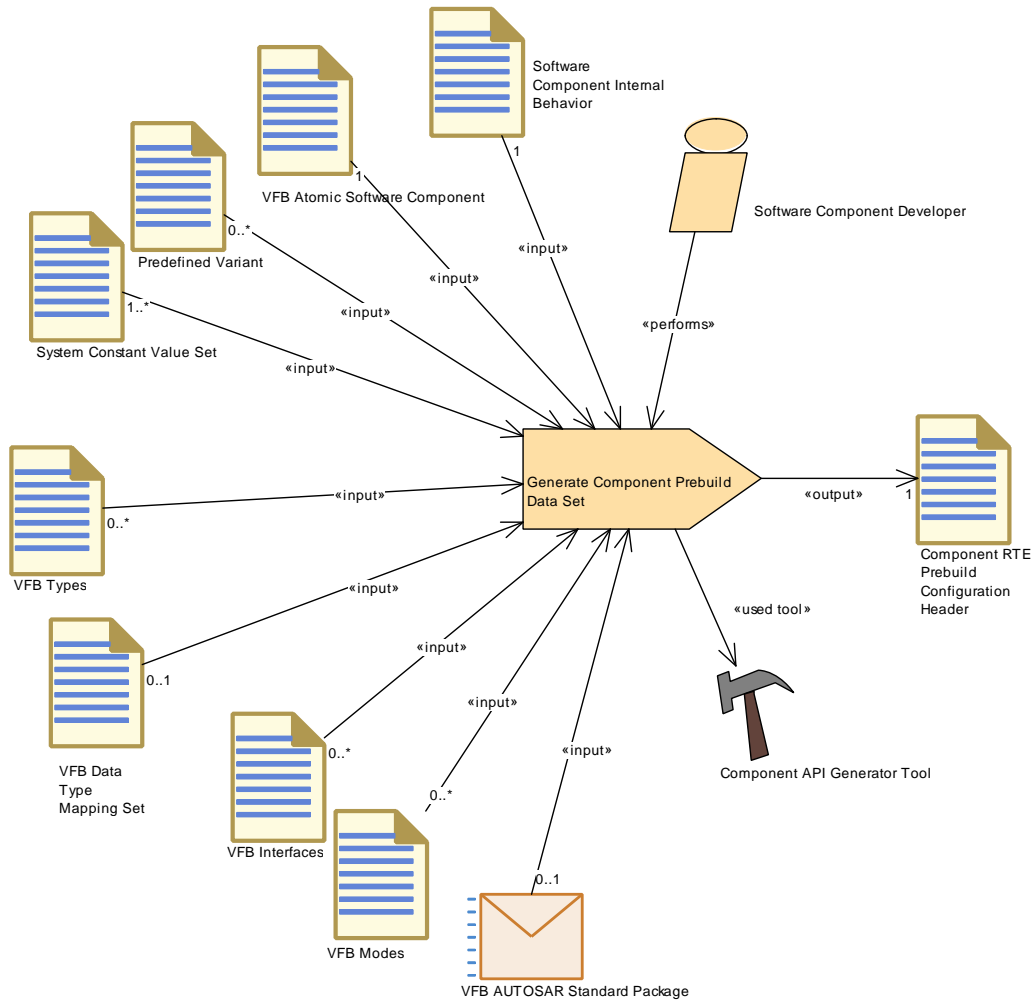
**Figure 3.75: Generate Component Header File in Vendor Mode**

<b>Task Definition</b>	<b>Generate Component Header File in Vendor Mode</b>		
<b>Package</b>	AUTOSAR Root::M2::Methodology::Methodology Library::Component::Tasks		
<b>Brief Description</b>	Generate an optimized component header file. This is achieved by using the RTE's vendor mode.		
<b>Description</b>	Generate an optimized component header file. This is achieved by using the RTE's vendor mode.  Meth.bindingTime = CodeGenerationTime		
<b>Relation Type</b>	<b>Related Element</b>	<b>Mul.</b>	<b>Note</b>
Performed by	Software Component Developer	1	
Performed by	ECU Integrator	0..1	
Consumes	Atomic Software Component Implementation	1	Meth.bindingTime = SystemDesignTime

<b>Relation Type</b>	<b>Related Element</b>	<b>Mul.</b>	<b>Note</b>
Consumes	<a href="#">Software Component Internal Behavior</a>	1	Meth.bindingTime = SystemDesignTime
Consumes	<a href="#">VFB Atomic Software Component</a>	1	Meth.bindingTime = SystemDesignTime
Consumes	<a href="#">VFB AUTOSAR Standard Package</a>	0..1	
Consumes	<a href="#">VFB Data Type Mapping Set</a>	0..1	Meth.bindingTime = SystemDesignTime
Consumes	<a href="#">VFB Interfaces</a>	0..*	Meth.bindingTime = SystemDesignTime
Consumes	<a href="#">VFB Modes</a>	0..*	Meth.bindingTime = SystemDesignTime
Consumes	<a href="#">VFB Types</a>	0..*	Meth.bindingTime = SystemDesignTime
Produces	<a href="#">Optimized Application Header File</a>	1	Meth.bindingTime = CodeGenerationTime
Produces	<a href="#">Software Component Data Types Header</a>	1	Meth.bindingTime = CodeGenerationTime
Used tool	<a href="#">Component API Generator Tool</a>	1	

**Table 3.150: Generate Component Header File in Vendor Mode**

### 3.4.1.8 Generate Component Prebuild Data Set



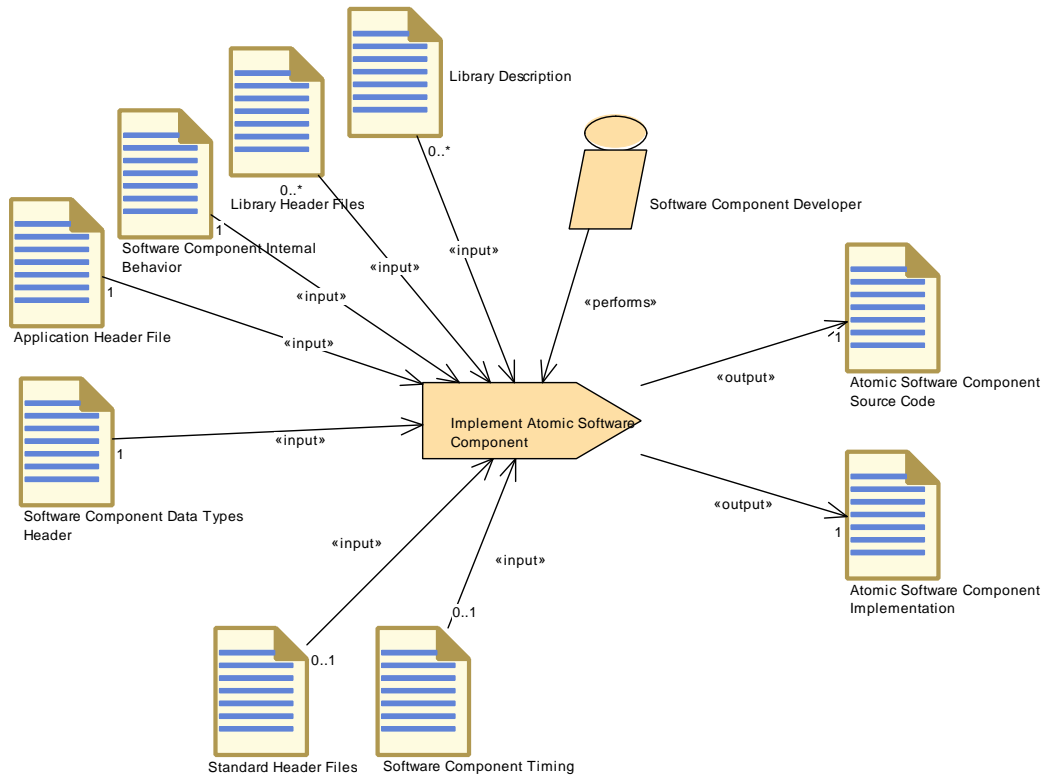
**Figure 3.76: Generate Component Prebuild Data Set**

<b>Task Definition</b>	<b>Generate Component Prebuild Data Set</b>		
<b>Package</b>	AUTOSAR Root::M2::Methodology::Methodology Library::Component::Tasks		
<b>Brief Description</b>	Prebuild Data Set Generation Phase for a software component: It binds all variations which need to be set after generation of the RTE contract header but before compilation of the component.		
<b>Description</b>	Prebuild Data Set Generation Phase for a software component: It binds all variations which need to be set after generation of the RTE contract header but before compilation of the component. The output is a configuration header which is used when compiling the component and the RTE as well.  Meth.bindingTime = PreCompileTime		
<b>Relation Type</b>	<b>Related Element</b>	<b>Mul.</b>	<b>Note</b>
Performed by	<a href="#">Software Component Developer</a>	1	

<b>Relation Type</b>	<b>Related Element</b>	<b>Mul.</b>	<b>Note</b>
Consumes	Software Component Internal Behavior	1	Meth.bindingTime = CodeGenerationTime
Consumes	VFB Atomic Software Component	1	Meth.bindingTime = CodeGenerationTime
Consumes	System Constant Value Set	1..*	Meth.bindingTime = CodeGenerationTime
Consumes	VFB AUTOSAR Standard Package	0..1	
Consumes	VFB Data Type Mapping Set	0..1	Meth.bindingTime = CodeGenerationTime
Consumes	Predefined Variant	0..*	
Consumes	VFB Interfaces	0..*	Meth.bindingTime = CodeGenerationTime
Consumes	VFB Modes	0..*	Meth.bindingTime = CodeGenerationTime
Consumes	VFB Types	0..*	Meth.bindingTime = CodeGenerationTime
Produces	Component RTE Prebuild Configuration Header	1	Meth.bindingTime = PreCompileTime
Used tool	Component API Generator Tool	1	

**Table 3.151: Generate Component Prebuild Data Set**

### 3.4.1.9 Implement Atomic Software Component



**Figure 3.77: Implement Atomic Software Component**

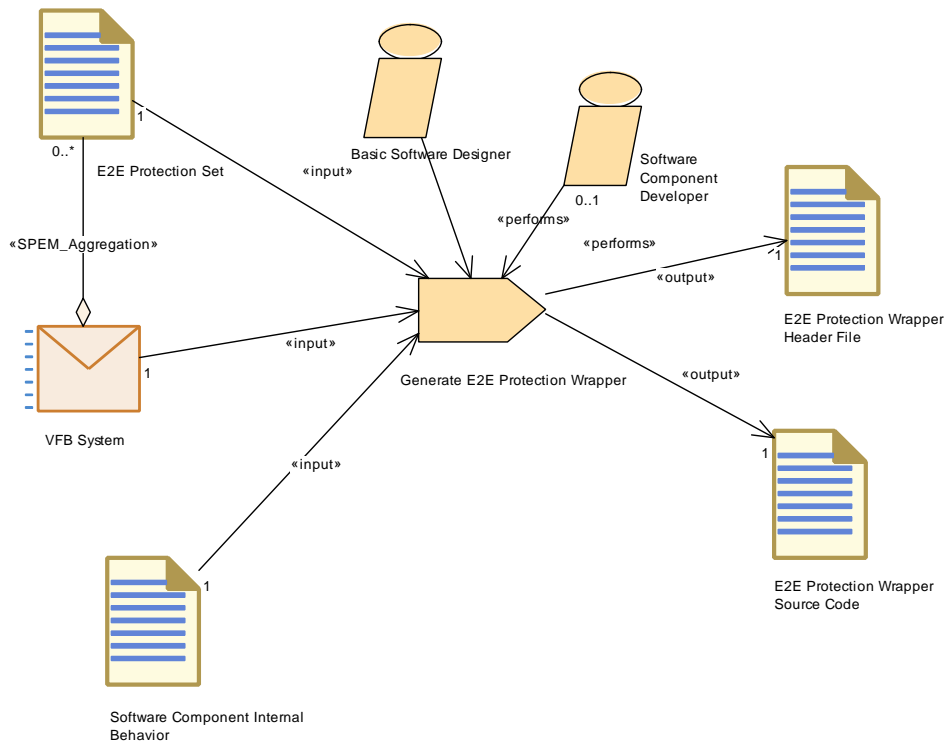
<b>Task Definition</b>	<b>Implement Atomic Software Component</b>		
<b>Package</b>	AUTOSAR Root::M2::Methodology::Methodology Library::Component::Tasks		
<b>Brief Description</b>	Implement the code of the AtomicSoftwareComponent and describe the Implementation.		
<b>Description</b>	Implement the code of the AtomicSoftwareComponent against the generated component contract header. Document the basic information in the Implementation Description.  Meth.bindingTime = CodeGenerationTime		
<b>Relation Type</b>	<b>Related Element</b>	<b>Mul.</b>	<b>Note</b>
Performed by	Software Component Developer	1	
Consumes	Application Header File	1	Meth.bindingTime = SystemDesignTime
Consumes	Software Component Data Types Header	1	Meth.bindingTime = SystemDesignTime
Consumes	Software Component Internal Behavior	1	Meth.bindingTime = SystemDesignTime
Consumes	Software Component Timing	0..1	Meth.bindingTime = SystemDesignTime



Relation Type	Related Element	Mul.	Note
Consumes	Standard Header Files	0..1	Meth.bindingTime = CodeGenerationTime
Consumes	Library Description	0..*	Meth.bindingTime = CodeGenerationTime
Consumes	Library Header Files	0..*	Meth.bindingTime = CodeGenerationTime
Produces	Atomic Software Component Implementation	1	Meth.bindingTime = CodeGenerationTime
Produces	Atomic Software Component Source Code	1	Meth.bindingTime = CodeGenerationTime

**Table 3.152: Implement Atomic Software Component**

**3.4.1.10 Generate E2E Protection Wrapper**

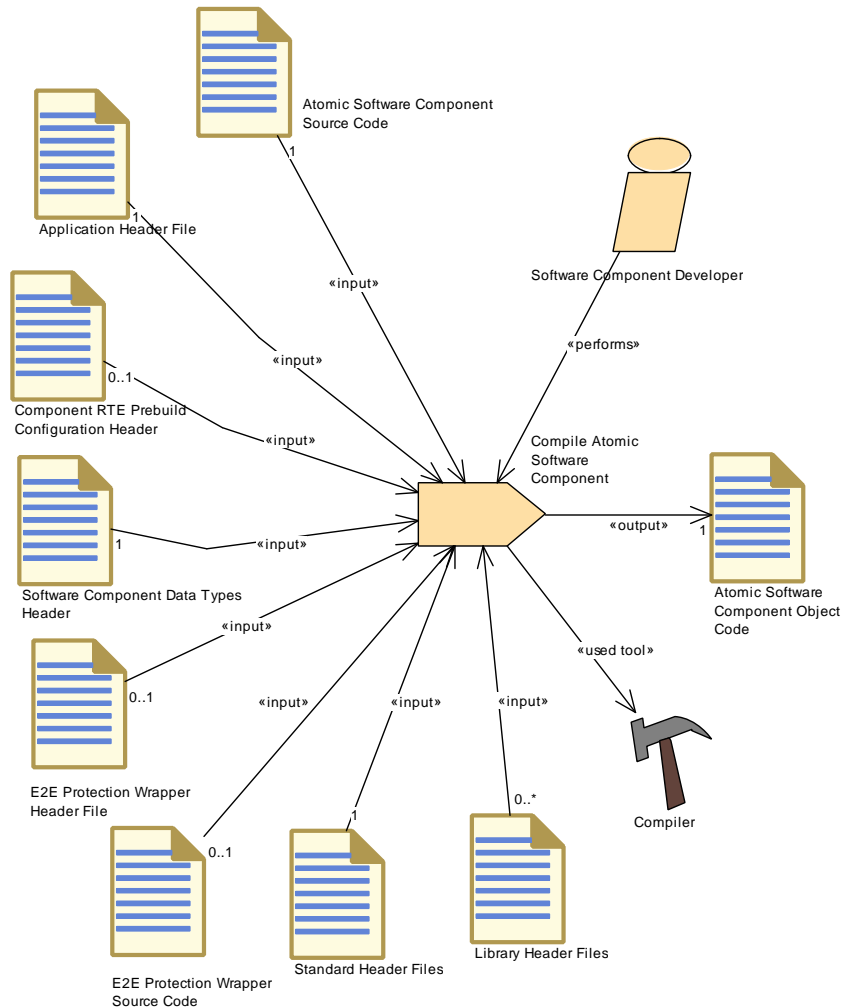


**Figure 3.78: Generate E2E Protection Wrapper**

<b>Task Definition</b>	<b>Generate E2E Protection Wrapper</b>		
<b>Package</b>	AUTOSAR Root::M2::Methodology::Methodology Library::Component::Tasks		
<b>Brief Description</b>	Generate E2E Protection Wrapper code		
<b>Description</b>	<p>Generate E2E Protection Wrapper code. The header and source code are generated based on the E2E profile chosen for particular data elements and ports.</p> <p>Meth.bindingTime = CodeGenerationTime</p>		
<b>Relation Type</b>	<b>Related Element</b>	<b>Mul.</b>	<b>Note</b>
Performed by	<a href="#">Basic Software Designer</a>	1	
Performed by	<a href="#">Software Component Developer</a>	0..1	
Consumes	<a href="#">E2E Protection Set</a>	1	Meth.bindingTime = SystemDesignTime
Consumes	<a href="#">Software Component Internal Behavior</a>	1	Meth.bindingTime = SystemDesignTime
Consumes	<a href="#">VFB System</a>	1	Use all elements (like VFB types) that are referred by E2E Protection Set Meth.bindingTime = SystemDesignTime
Produces	<a href="#">E2E Protection Wrapper Header File</a>	1	Meth.bindingTime = CodeGenerationTime
Produces	<a href="#">E2E Protection Wrapper Source Code</a>	1	Meth.bindingTime = CodeGenerationTime

**Table 3.153: Generate E2E Protection Wrapper**

### 3.4.1.11 Compile Atomic Software Component



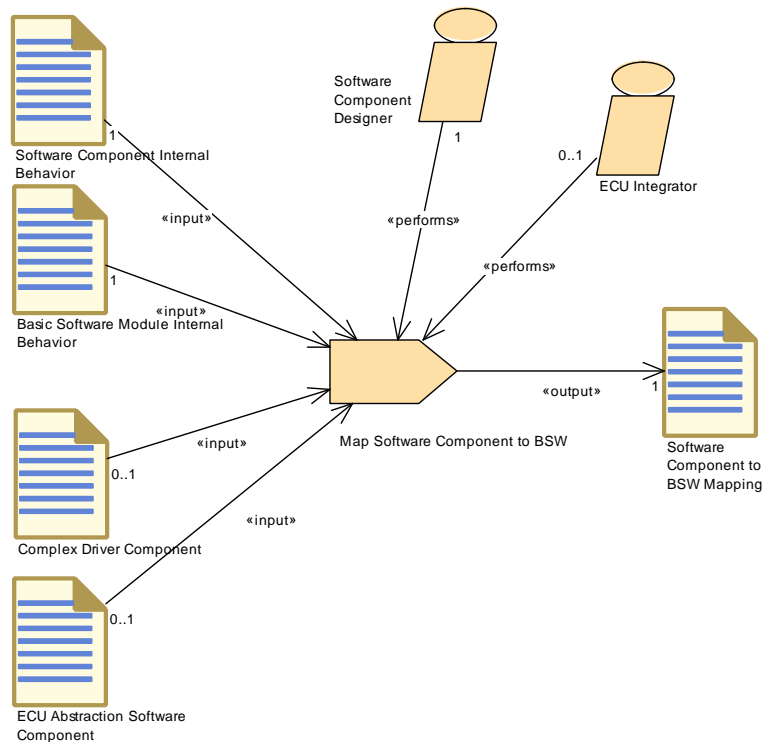
**Figure 3.79: Compile Atomic Software Component**

<b>Task Definition</b>	<b>Compile Atomic Software Component</b>		
<b>Package</b>	AUTOSAR Root::M2::Methodology::Methodology Library::Component::Tasks		
<b>Brief Description</b>	Compile the AtomicSoftwareComponent independently of an ECU.		
<b>Description</b>	Compile the Atomic Software Component independently of an ECU.  Meth.bindingTime = CompileTime		
<b>Relation Type</b>	<b>Related Element</b>	<b>Mul.</b>	<b>Note</b>
Performed by	Software Component Developer	1	
Consumes	Application Header File	1	Meth.bindingTime = CodeGenerationTime
Consumes	Atomic Software Component Source Code	1	Meth.bindingTime = CodeGenerationTime

<b>Relation Type</b>	<b>Related Element</b>	<b>Mul.</b>	<b>Note</b>
Consumes	Software Component Data Types Header	1	Meth.bindingTime = CodeGenerationTime
Consumes	Standard Header Files	1	Meth.bindingTime = CodeGenerationTime
Consumes	Component RTE Prebuild Configuration Header	0..1	Meth.bindingTime = PreCompileTime
Consumes	E2E Protection Wrapper Header File	0..1	Meth.bindingTime = CodeGenerationTime
Consumes	E2E Protection Wrapper Source Code	0..1	Meth.bindingTime = CodeGenerationTime
Consumes	Library Header Files	0..*	Meth.bindingTime = CodeGenerationTime
Produces	Atomic Software Component Object Code	1	The object file should include both code of the SWC and the E2E Protection Wrapper code (if present as an input). Meth.bindingTime = CompileTime
Used tool	Compiler	1	

**Table 3.154: Compile Atomic Software Component**

### 3.4.1.12 Map Software Component to BSW

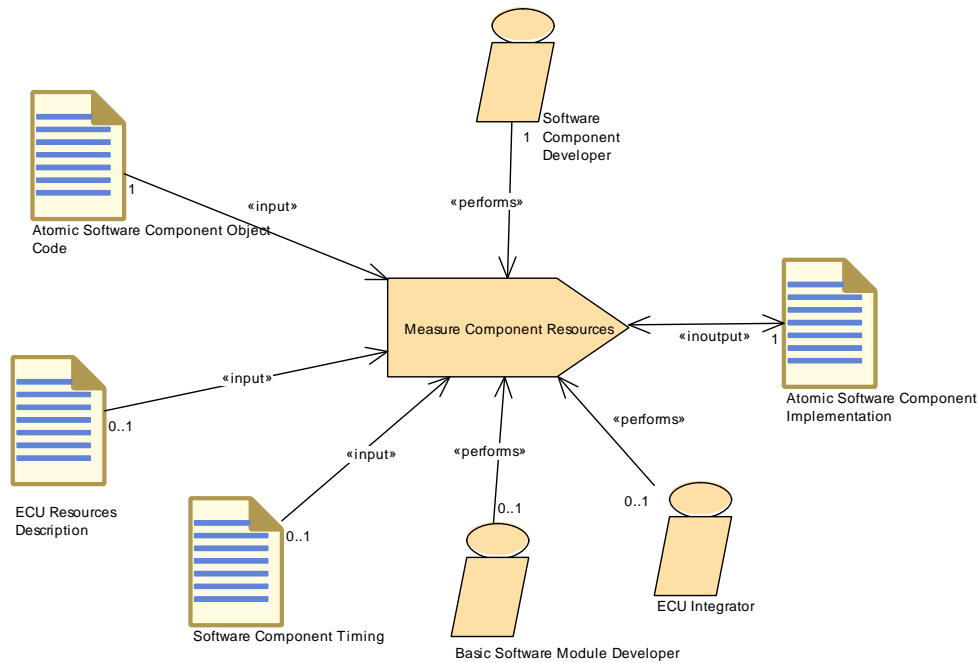


**Figure 3.80: Map Software Component to BSW**

<b>Task Definition</b>	<b>Map Software Component to BSW</b>		
<b>Package</b>	AUTOSAR Root::M2::Methodology::Methodology Library::Component::Tasks		
<b>Brief Description</b>	Define the mapping between a Software Component and a BSW Module.		
<b>Description</b>	Define the mapping between a Software Component and a BSW Module. Required only for Complex Drivers and ECU Abstraction Components. Note that for Service Components, this mapping will be generated in the ECU integration phase, so the latter is not considered as a task in the responsibility of the BSW developer.		
<b>Relation Type</b>	<b>Related Element</b>	<b>Mul.</b>	<b>Note</b>
Performed by	<a href="#">Software Component Designer</a>	1	
Performed by	<a href="#">ECU Integrator</a>	0..1	
Consumes	<a href="#">Basic Software Module Internal Behavior</a>	1	
Consumes	<a href="#">Software Component Internal Behavior</a>	1	
Consumes	<a href="#">Complex Driver Component</a>	0..1	
Consumes	<a href="#">ECU Abstraction Software Component</a>	0..1	
Produces	<a href="#">Software Component to BSW Mapping</a>	1	

**Table 3.155: Map Software Component to BSW**

### 3.4.1.13 Measure Component Resources



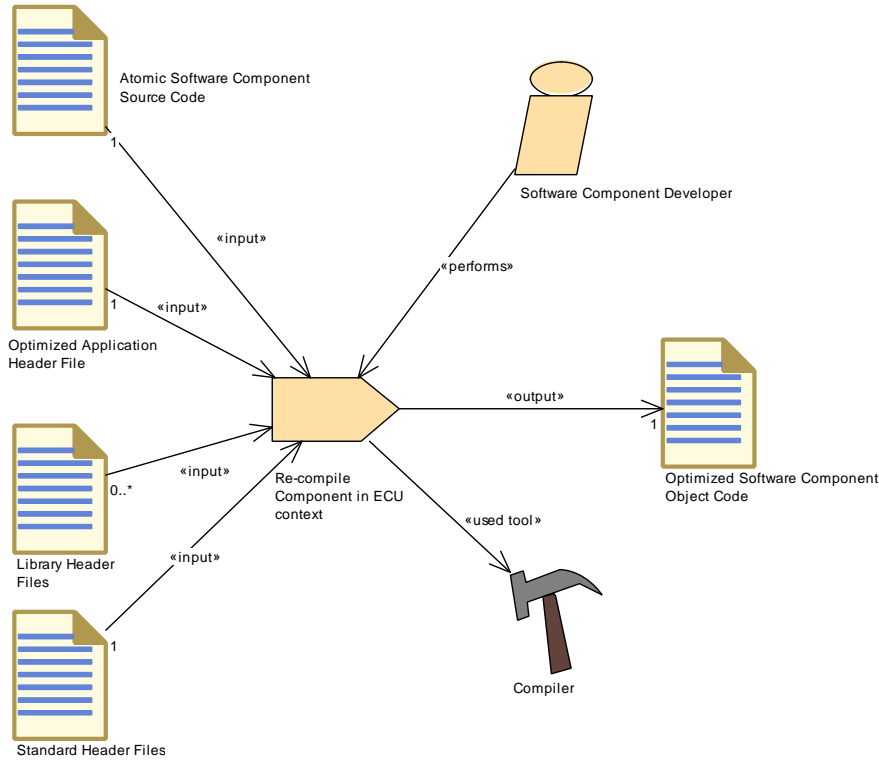
**Figure 3.81: Measure Component Resources**

<b>Task Definition</b>	<b>Measure Component Resources</b>		
<b>Package</b>	AUTOSAR Root::M2::Methodology::Methodology Library::Component::Tasks		
<b>Brief Description</b>	Measure the resource consumption of an Atomic Software Component		
<b>Description</b>	<p>Determine the resource consumption (memory, execution time) for a specific implementation of an Atomic Software Component in a certain context (ECU or test environment) and document the results in the Implementation description targeted at this specific platform.</p> <p>The ECU Resources Description is an optional input, because some results should be documented in relation to the hardware elements.</p>		
<b>Relation Type</b>	<b>Related Element</b>	<b>Mul.</b>	<b>Note</b>
Performed by	Software Component Developer	1	
Performed by	Basic Software Module Developer	0..1	
Performed by	ECU Integrator	0..1	
Consumes	Atomic Software Component Object Code	1	
Consumes	ECU Resources Description	0..1	
Consumes	Software Component Timing	0..1	
In/out	Atomic Software Component Implementation	1	

Relation Type	Related Element	Mul.	Note
---------------	-----------------	------	------

**Table 3.156: Measure Component Resources**

**3.4.1.14 Recompile Component in ECU Context**



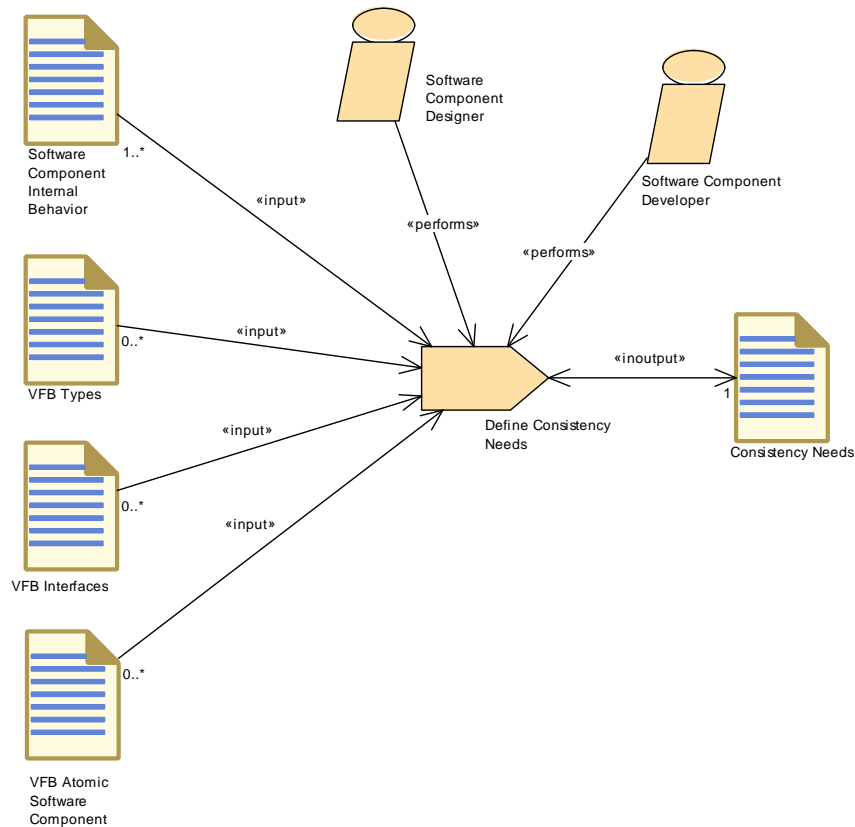
**Figure 3.82: Recompile Component in ECU Context**

<b>Task Definition</b>	<b>Re-compile Component in ECU context</b>		
<b>Package</b>	AUTOSAR Root::M2::Methodology::Methodology Library::Component::Tasks		
<b>Brief Description</b>	Re-compile Component with ECU-Configuration specific optimizations.		
<b>Description</b>	Re-compile Component with optimizations made by the RTE in the context of an ECU (so-called RTE implementation phase).  Meth.bindingTime = CompileTime		
<b>Relation Type</b>	<b>Related Element</b>	<b>Mul.</b>	<b>Note</b>
Performed by	Software Component Developer	1	
Consumes	Atomic Software Component Source Code	1	Meth.bindingTime = CodeGenerationTime
Consumes	Optimized Application Header File	1	Meth.bindingTime = CodeGenerationTime
Consumes	Standard Header Files	1	Meth.bindingTime = CodeGenerationTime

Relation Type	Related Element	Mul.	Note
Consumes	Library Header Files	0..*	Meth.bindingTime = CodeGenerationTime
Produces	Optimized Software Component Object Code	1	Meth.bindingTime = CompileTime
Used tool	Compiler	1	

**Table 3.157: Re-compile Component in ECU context**

### 3.4.1.15 Define Consistency Needs



**Figure 3.83: Define Consistency Needs**

Task Definition	Define Consistency Needs		
Package	AUTOSAR Root::M2::Methodology::Methodology Library::Component::Tasks		
Brief Description			
Description	Defines the consistency relations between a group of RunnableEntities and a group of DataPrototypes. The consistency relations can be defined first time at the design of an Atomic Software Component but can be added as well if Compositions are created.		
Relation Type	Related Element	Mul.	Note

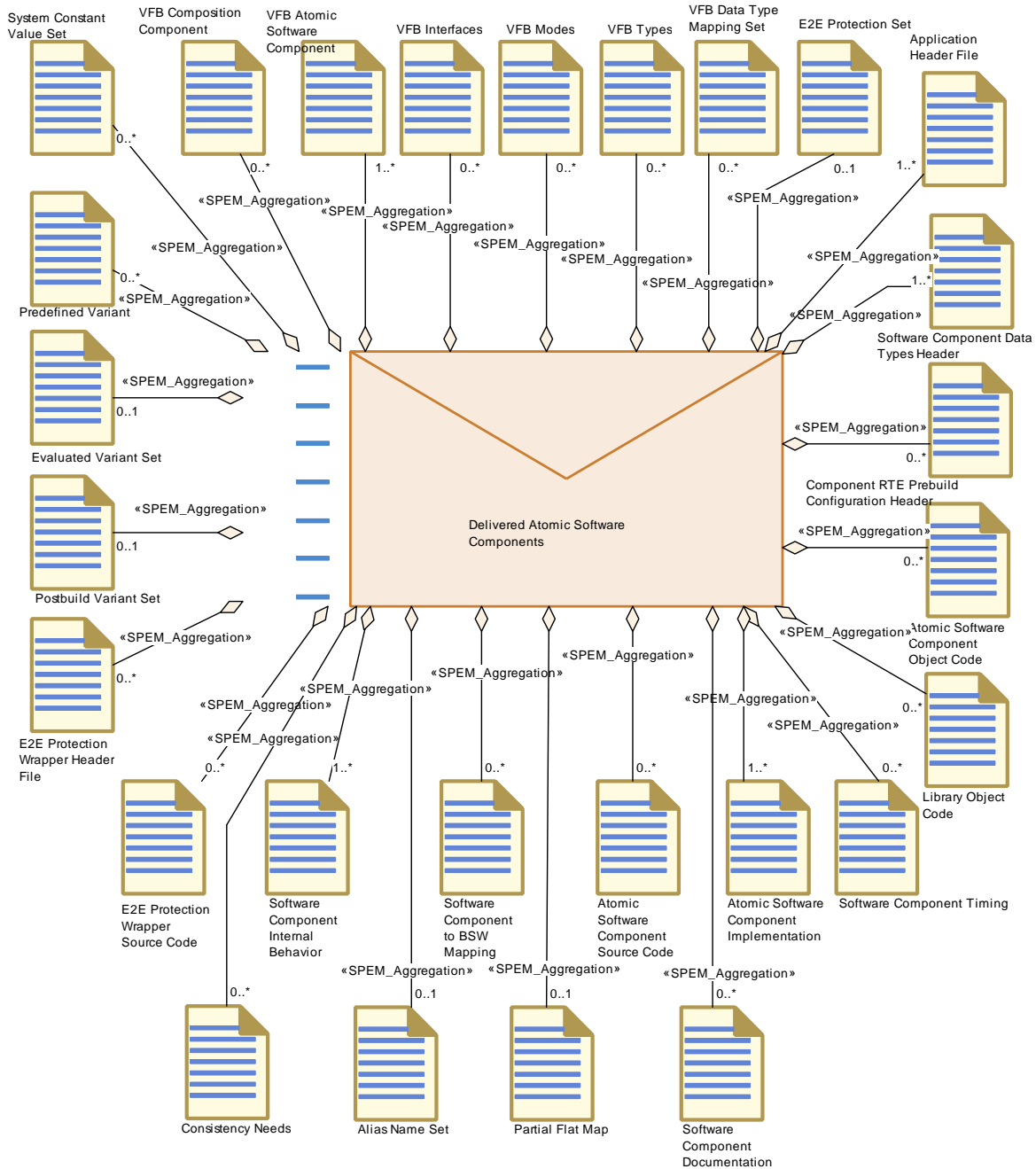


<i>Relation Type</i>	<i>Related Element</i>	<i>Mul.</i>	<i>Note</i>
Performed by	Software Component Designer	1	
Performed by	Software Component Developer	1	
Consumes	Software Component Internal Behavior	1..*	Runnablees the consistency is defined for.
Consumes	VFB Atomic Software Component	0..*	The description of an AtomicSoftwareComponentType without InternalBehavior.
Consumes	VFB Interfaces	0..*	Interfaces which are relevant for the consistency definition.
Consumes	VFB Types	0..*	Data types which are relevant for the consistency definition.
In/out	Consistency Needs	1	The description of the correlation between a group of RunnableEntitys and a group of DataPrototypes. In order to allow incremental development and refinement the Consistency Needs artifact is also used as an input.

**Table 3.158: Define Consistency Needs**

### 3.4.2 Work Products

#### 3.4.2.1 Delivered Atomic Software Components



**Figure 3.84: Delivered Atomic Software Components**

<b>Deliverable</b>	<b>Delivered Atomic Software Components</b>		
<b>Package</b>	AUTOSAR Root::M2::Methodology::Methodology Library::Component::Work Products		
<b>Brief Description</b>	Delivery of a set of AtomicSoftwareComponents including their Implementation.		
<b>Description</b>	<p>Complete description of a set of AtomicSoftwareComponents including Implementation (still standalone, not yet mapped to a specific ECU). The source or object code files are referred by the Implementation Description.</p> <p>The Atomic Software Components that make up the delivery may or may not form a composition (in the sense of the VFB).</p> <p>Note that the VFB descriptions of the components, compositions and the used interfaces are part of the deliverable too in order to describe the delivered components completely. However, depending on the use case, these parts could have been predefined and were treated as "readonly" during the component development. The same holds (optionally) for the Internal Behavior(s).</p> <p>A Timing Model and a mapping set between Application and Implementation Data Types are included optionally.</p> <p>The delivery can optionally also contain variants (an Evaluated Variant Set and the related artifacts).</p>		
<b>Kind</b>	Delivered		
<b>Relation Type</b>	<b>Related Element</b>	<b>Mul.</b>	<b>Note</b>
Aggregates	<a href="#">Application Header File</a>	1..*	
Aggregates	<a href="#">Atomic Software Component Implementation</a>	1..*	
Aggregates	<a href="#">Software Component Data Types Header</a>	1..*	
Aggregates	<a href="#">Software Component Internal Behavior</a>	1..*	
Aggregates	<a href="#">VFB Atomic Software Component</a>	1..*	
Aggregates	<a href="#">Alias Name Set</a>	0..1	Alias names valid in the context of the delivered components.
Aggregates	<a href="#">E2E Protection Set</a>	0..1	
Aggregates	<a href="#">Evaluated Variant Set</a>	0..1	
Aggregates	<a href="#">Partial Flat Map</a>	0..1	
Aggregates	<a href="#">Postbuild Variant Set</a>	0..1	
Aggregates	<a href="#">Atomic Software Component Object Code</a>	0..*	

<b>Relation Type</b>	<b>Related Element</b>	<b>Mul.</b>	<b>Note</b>
Aggregates	Atomic Software Component Source Code	0..*	
Aggregates	Component RTE Prebuild Configuration Header	0..*	
Aggregates	Consistency Needs	0..*	Correlation between a group of RunnableEntitys and a group of DataPrototypes.
Aggregates	E2E Protection Wrapper Header File	0..*	
Aggregates	E2E Protection Wrapper Source Code	0..*	
Aggregates	Library Object Code	0..*	
Aggregates	Predefined Variant	0..*	
Aggregates	Software Component Documentation	0..*	
Aggregates	Software Component Timing	0..*	
Aggregates	Software Component to BSW Mapping	0..*	
Aggregates	System Constant Value Set	0..*	
Aggregates	VFB Composition Component	0..*	In case the delivered atomic components make up one or more VFB Compositions, the composition description(s) shall be included in the delivery.
Aggregates	VFB Data Type Mapping Set	0..*	
Aggregates	VFB Interfaces	0..*	
Aggregates	VFB Modes	0..*	
Aggregates	VFB Types	0..*	
Produced by	Develop Application Software	1..*	
Consumed by	Configure RTE	1..*	<p>Required input:</p> <ul style="list-style-type: none"> <li>References to all component implementation descriptions on this ECU</li> <li>SwcInternalBehavior (for example to map the runnables to tasks) which was used in the contract phase of the software components on this ECU</li> </ul>

<b>Relation Type</b>	<b>Related Element</b>	<b>Mul.</b>	<b>Note</b>
Consumed by	<a href="#">Generate RTE</a>	1..*	Required input: <ul style="list-style-type: none"> <li>References to all component implementation descriptions on this ECU</li> <li>SwcInternalBehavior which was used in the contract phase of the software components on this ECU</li> <li>(optional) Software Component to BSW Mapping</li> </ul> Meth.bindingTime = SystemDesignTime
Consumed by	<a href="#">Integrate Software for ECU</a>	1..*	
Consumed by	<a href="#">Define Alias Names</a>	0..1	Needed for definition of alias names in the scope of delivered software components.
Consumed by	<a href="#">Create MC Function Model</a>	0..*	The component model may be used to derive an MC Function Model.

**Table 3.159: Delivered Atomic Software Components**

### 3.4.2.2 Software Component Internal Behavior

<b>Artifact</b>	<b>Software Component Internal Behavior</b>		
<b>Package</b>	AUTOSAR Root::M2::Methodology::Methodology Library::Component::Work Products		
<b>Brief Description</b>	Description of the InternalBehavior: It describes the RTE relevant aspects of a component, for example the runnable entities and the events they respond to.		
<b>Description</b>	Description of the Internal Behavior. The Internal Behavior of an Atomic Software Component describes the RTE relevant aspects of a component, i.e. the runnable entities and the events they respond to. It is used to generate the RTE but also as input for parts of the basic software generation (AUTOSAR Services). The Internal Behavior (i.e. the XML description) can only be used together with an Atomic Software Component Type to which it is related.		
<b>Kind</b>	AUTOSAR XML		
<b>Relation Type</b>	<b>Related Element</b>	<b>Mul.</b>	<b>Note</b>
Aggregated by	<a href="#">Delivered Atomic Software Components</a>	1..*	
Produced by	<a href="#">Define Atomic Software Component Internal Behavior</a>	1	
Consumed by	<a href="#">Define Software Component Timing</a>	1	

<b>Relation Type</b>	<b>Related Element</b>	<b>Mul.</b>	<b>Note</b>
Consumed by	Generate Atomic Software Component Contract Header Files	1	Meth.bindingTime = SystemDesignTime
Consumed by	Generate Component Header File in Vendor Mode	1	Meth.bindingTime = SystemDesignTime
Consumed by	Generate Component Prebuild Data Set	1	Meth.bindingTime = CodeGenerationTime
Consumed by	Generate E2E Protection Wrapper	1	Meth.bindingTime = SystemDesignTime
Consumed by	Implement Atomic Software Component	1	Meth.bindingTime = SystemDesignTime
Consumed by	Map Software Component to BS W	1	
Consumed by	Define Consistency Needs	1..*	Runnables the consistency is defined for.
Consumed by	Select Software Component Implementation	1..*	
Consumed by	Generate Local M C Data Support	0..1	Meth.bindingTime = SystemDesignTime
Consumed by	Define Partial Flat Map	0..*	Refer to parameter and variables defined in the Internal Behavior of one or more Atomic Software Components.
Use meta model element	SwcInternalBehavior	1	

**Table 3.160: Software Component Internal Behavior**

### 3.4.2.3 Atomic Software Component Implementation

<b>Artifact</b>	<b>Atomic Software Component Implementation</b>		
<b>Package</b>	AUTOSAR Root::M2::Methodology::Methodology Library::Component::Work Products		
<b>Brief Description</b>	Description of an implementation for a single Atomic Software Component.		
<b>Description</b>	<p>Description of an implementation for a single Atomic Software Component. It is possible to have several different implementations for the same Software Component Internal Behavior, but only one implementation can be mapped to a particular ECU. In general, this XML artifact relates to one particular version of the code. It contains the version information as defined by the vendor.</p> <p>An implementation description may depend on several non-AUTOSAR artifacts, especially its own code files (source or object) but also required libraries, generator tools etc. These dependencies are not described by direct references to files (because this might be ambiguous), but by referring entries in the container catalog of the General Deliverable which contains the implementation artifacts. Such a reference is described via the metamodel element <code>AutosarEngineeringObject</code> (see <code>AUTOSAR_TPS_GenericStructureTemplate.pdf</code> for further description). This allows among other things to refer to a particular version of an artifact.</p> <p>For more information on the content of the implementation description refer to <code>AUTOSAR_TPS_BSWModuleDescriptionTemplate.pdf</code>.</p>		
<b>Kind</b>	AUTOSAR XML		
<b>Relation Type</b>	<b>Related Element</b>	<b>Mul.</b>	<b>Note</b>
Aggregated by	<a href="#">Delivered Atomic Software Components</a>	1..*	
Produced by	<a href="#">Create Service Component</a>	1	In order to generate the RTE, one needs to create a kind of dummy Implementation element for the Service Component, however this should not be filled with descriptive elements, e.g. resource consumption, as these are already defined by the Basic Software Module Implementation Description. Meth.bindingTime = SystemDesignTime
Produced by	<a href="#">Implement Atomic Software Component</a>	1	Meth.bindingTime = CodeGenerationTime
Produced by	<a href="#">Measure Resources</a>	0..*	Add extensions to the Implementation Description. Meth.bindingTime = PostBuild
In/out	<a href="#">Measure Component Resources</a>	1	
Consumed by	<a href="#">Generate Component Header File in Vendor Mode</a>	1	Meth.bindingTime = SystemDesignTime

<i>Relation Type</i>	<i>Related Element</i>	<i>Mul.</i>	<i>Note</i>
Consumed by	Generate SWC Memory Mapping Header	1	MemorySections: MemorySections defined for an Atomic Software Component. Meth.bindingTime = SystemDesignTime
Consumed by	Select Software Component Implementation	1..*	
Consumed by	Configure Memmap Allocation	0..*	MemorySections:
Consumed by	Generate Compiler Configuration	0..*	MemorySections: Find referred SwAddrMethods or specific memClassSymbols in the MemorySections defined for Atomic Software Components. Meth.bindingTime = SystemDesignTime
Use meta model element	Implementation	1	

**Table 3.161: Atomic Software Component Implementation**

### 3.4.2.4 Software Component Documentation

<i>Artifact</i>	<b>Software Component Documentation</b>		
<b>Package</b>	AUTOSAR Root::M2::Methodology::Methodology Library::Component::Work Products		
<b>Brief Description</b>	Documentation dedicated to a Software Component.		
<b>Description</b>	<p>Documentation of a dedicated Software Component. This documentation is following the ASAM FSX standard. In this documentation, you will find the SW Feature definition and description which define the physical functionality of the Swc, the SW test description which will contains suggestions and hints for the test of the software functionality of the Swc, the SW calibration notes which will give calibration instructions and hints for a calibration engineer, some maintenance, diagnosis and CARB notes which will bring general information, on the maintenance diagnosis and CARB issues on the Swc. For other description not listed previously, some notes (chapters) are left free for that.</p> <p>This artifact may also contain standalone documentation (meta-class Documentation) not aggregated by a specific software component.</p>		
<b>Kind</b>	AUTOSAR XML		
<i>Relation Type</i>	<i>Related Element</i>	<i>Mul.</i>	<i>Note</i>
Aggregated by	Delivered Atomic Software Components	0..*	
In/out	Add Documentation to the Software Component	1	
Use meta model element	Documentation	1	
Use meta model element	SwComponent Documentation	1	



<i>Relation Type</i>	<i>Related Element</i>	<i>Mul.</i>	<i>Note</i>
----------------------	------------------------	-------------	-------------

**Table 3.162: Software Component Documentation**

### 3.4.2.5 Software Component Timing

<i>Artifact</i>	<b>Software Component Timing</b>		
<b>Package</b>	AUTOSAR Root::M2::Methodology::Methodology Library::Component::Work Products		
<b>Brief Description</b>	Software Component's TimingDescription and TimingConstraints		
<b>Description</b>	<p>TimingDescription and TimingConstraints of a software component. A software component can either be of type AtomicSWComponentType or CompositionSWComponentType.</p> <p>In the former case, the SwcTiming allows to describe timing description and constraints for the InternalBehavior of the AtomicSWComponentType.</p> <p>In the latter case, timing descriptions and constraints can be defined for all Atomic Software Components in the CompositionSWComponentType.</p>		
<b>Kind</b>	AUTOSAR XML		
<i>Relation Type</i>	<i>Related Element</i>	<i>Mul.</i>	<i>Note</i>
Aggregated by	<a href="#">Delivered Atomic Software Components</a>	0..*	
Produced by	<a href="#">Define Software Component Timing</a>	1	
Consumed by	<a href="#">Define System Timing</a>	0..1	
Consumed by	<a href="#">Implement Atomic Software Component</a>	0..1	Meth.bindingTime = SystemDesignTime
Consumed by	<a href="#">Measure Component Resources</a>	0..1	
Use meta model element	SwcTiming	1	

**Table 3.163: Software Component Timing**

### 3.4.2.6 Software Component to BSW Mapping

<b>Artifact</b>	<b>Software Component to BSW Mapping</b>		
<b>Package</b>	AUTOSAR Root::M2::Methodology::Methodology Library::Component::Work Products		
<b>Brief Description</b>	Describes how to map a software component to basic software elements (required in special cases only).		
<b>Description</b>	Maps an SwcInternalBehavior to an BswInternalBehavior. This is required to coordinate the API generation and the scheduling for AUTOSAR Service Components, ECU Abstraction Components and Complex Driver Components by the RTE and the BSW scheduling mechanisms.		
<b>Kind</b>	AUTOSAR XML		
<b>Relation Type</b>	<b>Related Element</b>	<b>Mul.</b>	<b>Note</b>
Aggregated by	<a href="#">Delivered Atomic Software Components</a>	0..*	
Produced by	<a href="#">Map Software Component to BSW</a>	1	
Produced by	<a href="#">Create Service Component</a>	0..1	Meth.bindingTime = SystemDesignTime
Consumed by	<a href="#">Generate Atomic Software Component Contract Header Files</a>	0..1	If a Software Component is mapped to a BSW module description, this input is optionally needed already in the contract phase in order to ensure that the generated prototypes for runnables are consistent with the definitions in Software Component and BSW. Meth.bindingTime = SystemDesignTime
Consumed by	<a href="#">Generate RTE</a>	0..*	This input is explicitly stated because the mapping may be created during ECU integration and thus is not necessarily part of the Delivered Atomic Software Components. Meth.bindingTime = SystemDesignTime
Use meta model element	SwcBswMapping	1	

**Table 3.164: Software Component to BSW Mapping**

### 3.4.2.7 Partial Flat Map

<b>Artifact</b>	<b>Partial Flat Map</b>		
<b>Package</b>	AUTOSAR Root::M2::Methodology::Methodology Library::Component::Work Products		
<b>Brief Description</b>			
<b>Description</b>	<p>The Partial Flat Map pre-defines Flat Map entries in the context of delivered software components. This allows the component developer to specify names of data instances for measurement and calibration. It has to be integrated into the System Flat Map.</p> <p>For more information on the Flat Map concept refer to artifact System Flat Map in the system domain.</p>		
<b>Kind</b>	AUTOSAR XML		
<b>Relation Type</b>	<b>Related Element</b>	<b>Mul.</b>	<b>Note</b>
Aggregated by	<a href="#">Delivered Atomic Software Components</a>	0..1	
Produced by	<a href="#">Define Partial Flat Map</a>	1	
Consumed by	<a href="#">Add Documentation to the Software Component</a>	0..1	Optional input in order to refer to unique names defined in component or composition context.
Consumed by	<a href="#">Generate or Adjust ECU Flat Map</a>	0..*	<p>If Partial Flat Maps were delivered along with software components referring only to ECU internal information, they may be integrated into the ECU Flat Map directly, i.e. without needing the System Flat Map.</p> <ul style="list-style-type: none"> <li>• The instance refs used in a partial flat map must be taken over and adjusted to the context ECU Extract.</li> <li>• Name conflicts have to be resolved if several partial flat maps are merged.</li> </ul>
Consumed by	<a href="#">Generate or Adjust System Flat Map</a>	0..*	<p>If Partial Flat Maps were delivered along with software components, they must be integrated into the System Flat Map:</p> <ul style="list-style-type: none"> <li>• The instance refs used in a partial flat map must be taken over and adjusted to the context of the System or System Extract.</li> <li>• Name conflicts have to be resolved if several partial flat maps are merged.</li> </ul>
Use meta model element	FlatMap	1	

**Table 3.165: Partial Flat Map**

### 3.4.2.8 Application Header File

<b>Artifact</b>	<b>Application Header File</b>		
<b>Package</b>	AUTOSAR Root::M2::Methodology::Methodology Library::Component::Work Products		
<b>Brief Description</b>	Header generated for an AtomicSoftwareComponentType in the RTE contract phase.		
<b>Description</b>	Header generated for an AtomicSoftwareComponentType in the RTE contract phase. It represents the complete source-code interface between the component code and RTE (calls into the RTE as well as prototypes called by the RTE). All communication of the component code with other components is routed through this header.		
<b>Kind</b>	Source Code		
<b>Relation Type</b>	<b>Related Element</b>	<b>Mul.</b>	<b>Note</b>
Aggregated by	<a href="#">Delivered Atomic Software Components</a>	1..*	
Produced by	<a href="#">Generate Atomic Software Component Contract Header Files</a>	1	Meth.bindingTime = CodeGenerationTime
Consumed by	<a href="#">Compile Atomic Software Component</a>	1	Meth.bindingTime = CodeGenerationTime
Consumed by	<a href="#">Implement Atomic Software Component</a>	1	Meth.bindingTime = SystemDesignTime
Consumed by	<a href="#">Compile ECU Source Code</a>	1..*	Meth.bindingTime = CodeGenerationTime

**Table 3.166: Application Header File**

### 3.4.2.9 Software Component Data Types Header

<b>Artifact</b>	<b>Software Component Data Types Header</b>		
<b>Package</b>	AUTOSAR Root::M2::Methodology::Methodology Library::Component::Work Products		
<b>Brief Description</b>	Software Component Data Types Header provided by the RTE in the contract phase.		
<b>Description</b>	Software Component Data Types Header provided by the RTE in the contract phase. This includes data types, which were declared as part of the SWC description but not used in any ports or data elements.		
<b>Kind</b>	Source Code		
<b>Relation Type</b>	<b>Related Element</b>	<b>Mul.</b>	<b>Note</b>
Aggregated by	<a href="#">Delivered Atomic Software Components</a>	1..*	

<i>Relation Type</i>	<i>Related Element</i>	<i>Mul.</i>	<i>Note</i>
Produced by	Generate Atomic Software Component Contract Header Files	1	Meth.bindingTime = CodeGenerationTime
Produced by	Generate Component Header File in Vendor Mode	1	Meth.bindingTime = CodeGenerationTime
Consumed by	Compile Atomic Software Component	1	Meth.bindingTime = CodeGenerationTime
Consumed by	Implement Atomic Software Component	1	Meth.bindingTime = SystemDesignTime
Consumed by	Compile ECU Source Code	0..*	Meth.bindingTime = CodeGenerationTime

**Table 3.167: Software Component Data Types Header**

### 3.4.2.10 Component RTE Prebuild Configuration Header

<i>Artifact</i>	<b>Component RTE Prebuild Configuration Header</b>		
<i>Package</i>	AUTOSAR Root::M2::Methodology::Methodology Library::Component::Work Products		
<i>Brief Description</i>	Generated header file used to resolve the prebuild variants in the prebuild RTE contract phase for an SWC.		
<i>Description</i>	Generated header file used to resolve the prebuild variants of a software component in the prebuild RTE contract phase. Contains macros which resolve the variants when compiled with the module and the generated RTE.		
<i>Kind</i>	Bound Source Code		
<i>Relation Type</i>	<i>Related Element</i>	<i>Mul.</i>	<i>Note</i>
Aggregated by	Delivered Atomic Software Components	0..*	
Produced by	Generate Component Prebuild Data Set	1	Meth.bindingTime = PreCompileTime
Consumed by	Compile Atomic Software Component	0..1	Meth.bindingTime = PreCompileTime
Consumed by	Compile ECU Source Code	0..*	Meth.bindingTime = CodeGenerationTime

**Table 3.168: Component RTE Prebuild Configuration Header**

### 3.4.2.11 E2E Protection Wrapper Header File

<b>Artifact</b>	<b>E2E Protection Wrapper Header File</b>		
<b>Package</b>	AUTOSAR Root::M2::Methodology::Methodology Library::Component::Work Products		
<b>Brief Description</b>			
<b>Description</b>	This header replaces the RTE API in order to do safe communication over ports. It redirects the calls from a software component to the RTE so that the E2E Protection Wrapper is executed.		
<b>Kind</b>	Source Code		
<b>Relation Type</b>	<b>Related Element</b>	<b>Mul.</b>	<b>Note</b>
Aggregated by	<a href="#">Delivered Atomic Software Components</a>	0..*	
Produced by	<a href="#">Generate E2E Protection Wrapper</a>	1	Meth.bindingTime = CodeGenerationTime
Consumed by	<a href="#">Compile Atomic Software Component</a>	0..1	Meth.bindingTime = CodeGenerationTime

**Table 3.169: E2E Protection Wrapper Header File**

### 3.4.2.12 E2E Protection Wrapper Source Code

<b>Artifact</b>	<b>E2E Protection Wrapper Source Code</b>		
<b>Package</b>	AUTOSAR Root::M2::Methodology::Methodology Library::Component::Work Products		
<b>Brief Description</b>			
<b>Description</b>	<p>A piece of code that is placed between software components and the RTE in order to provide E2E safety over ports. For data elements with specified E2E safety, the wrapper takes care</p> <ul style="list-style-type: none"> <li>• that the appropriate signature is added to the data if the data is written to the RTE</li> <li>• that the signature is checked if the data is read from the RTE</li> </ul> <p>Typically it uses a specific library to perform these actions.</p>		
<b>Kind</b>	Source Code		
<b>Relation Type</b>	<b>Related Element</b>	<b>Mul.</b>	<b>Note</b>
Aggregated by	<a href="#">Delivered Atomic Software Components</a>	0..*	
Produced by	<a href="#">Generate E2E Protection Wrapper</a>	1	Meth.bindingTime = CodeGenerationTime
Consumed by	<a href="#">Compile Atomic Software Component</a>	0..1	Meth.bindingTime = CodeGenerationTime

**Table 3.170: E2E Protection Wrapper Source Code**

### 3.4.2.13 Atomic Software Component Source Code

<b>Artifact</b>	<b>Atomic Software Component Source Code</b>		
<b>Package</b>	AUTOSAR Root::M2::Methodology::Methodology Library::Component::Work Products		
<b>Brief Description</b>	Source code implementing an Atomic Software Component Type		
<b>Description</b>	Source code implementing an Atomic Software Component Type. In general it is independent from an ECU.		
<b>Kind</b>	Source Code		
<b>Relation Type</b>	<b>Related Element</b>	<b>Mul.</b>	<b>Note</b>
Aggregated by	<a href="#">Delivered Atomic Software Components</a>	0..*	
Produced by	<a href="#">Implement Atomic Software Component</a>	1	Meth.bindingTime = CodeGenerationTime
Consumed by	<a href="#">Compile Atomic Software Component</a>	1	Meth.bindingTime = CodeGenerationTime
Consumed by	<a href="#">Re-compile Component in ECU context</a>	1	Meth.bindingTime = CodeGenerationTime
Consumed by	<a href="#">Compile ECU Source Code</a>	0..*	Meth.bindingTime = CodeGenerationTime

**Table 3.171: Atomic Software Component Source Code**

### 3.4.2.14 Atomic Software Component Object Code

<b>Artifact</b>	<b>Atomic Software Component Object Code</b>		
<b>Package</b>	AUTOSAR Root::M2::Methodology::Methodology Library::Component::Work Products		
<b>Brief Description</b>			
<b>Description</b>	Object Code of an Atomic Software Component.		
<b>Kind</b>	Object Code		
<b>Relation Type</b>	<b>Related Element</b>	<b>Mul.</b>	<b>Note</b>
Aggregated by	<a href="#">Delivered Atomic Software Components</a>	0..*	
Produced by	<a href="#">Compile Atomic Software Component</a>	1	The object file should include both code of the SWC and the E2E Protection Wrapper code (if present as an input). Meth.bindingTime = CompileTime
Consumed by	<a href="#">Measure Component Resources</a>	1	
Consumed by	<a href="#">Generate ECU Executable</a>	0..*	Meth.bindingTime = CompileTime

**Table 3.172: Atomic Software Component Object Code**

### 3.4.2.15 Optimized Application Header File

<b>Artifact</b>	<b>Optimized Application Header File</b>		
<b>Package</b>	AUTOSAR Root::M2::Methodology::Methodology Library::Component::Work Products		
<b>Brief Description</b>	Optimized application header file for a software component.		
<b>Description</b>	Application header file for a software component optimized by the RTE in vendor mode.		
<b>Kind</b>	Source Code		
<b>Relation Type</b>	<b>Related Element</b>	<b>Mul.</b>	<b>Note</b>
Produced by	<a href="#">Generate Component Header File in Vendor Mode</a>	1	Meth.bindingTime = CodeGenerationTime
Consumed by	<a href="#">Re-compile Component in ECU context</a>	1	Meth.bindingTime = CodeGenerationTime
Consumed by	<a href="#">Compile ECU Source Code</a>	0..*	Meth.bindingTime = CodeGenerationTime

**Table 3.173: Optimized Application Header File**

### 3.4.2.16 Optimized Software Component Object Code

<b>Artifact</b>	<b>Optimized Software Component Object Code</b>		
<b>Package</b>	AUTOSAR Root::M2::Methodology::Methodology Library::Component::Work Products		
<b>Brief Description</b>	The object code of a software component compiled with ECU specific optimizations.		
<b>Description</b>	The object code of a software component compiled with ECU specific optimizations.		
<b>Kind</b>	Object Code		
<b>Relation Type</b>	<b>Related Element</b>	<b>Mul.</b>	<b>Note</b>
Produced by	<a href="#">Re-compile Component in ECU context</a>	1	Meth.bindingTime = CompileTime

**Table 3.174: Optimized Software Component Object Code**

### 3.4.2.17 Consistency Needs



<b>Artifact</b>	<b>Consistency Needs</b>		
<b>Package</b>	AUTOSAR Root::M2::Methodology::Methodology Library::Component::Work Products		
<b>Brief Description</b>			
<b>Description</b>	<p>A ConsistencyNeed describes the correlation between a group of RunnableEntitys and a group of DataPrototypes with the intended purpose to describe the need for</p> <ul style="list-style-type: none"> <li>• Stable data during the execution of a group of RunnableEntitys.</li> <li>• Coherent data consumption and propagation for a group of DataPrototypes.</li> </ul> <p>The information can be defined first time at the design of an Atomic Software Component but can be added as well if Compositions are created. In order to allow incremental development the groups of Runnables and DataPrototypes can be distributed over several artifacts.</p>		
<b>Kind</b>			
<b>Relation Type</b>	<b>Related Element</b>	<b>Mul.</b>	<b>Note</b>
Aggregated by	<a href="#">VFB System</a>	1	Correlation between a group of RunnableEntitys and a group of DataPrototypes.
Aggregated by	<a href="#">Delivered Atomic Software Components</a>	0..*	Correlation between a group of RunnableEntitys and a group of DataPrototypes.
In/out	<a href="#">Define Consistency Needs</a>	1	The description of the correlation between a group of RunnableEntitys and a group of DataPrototypes. In order to allow incremental development and refinement the Consistency Needs artifact is also used as an input.
Use meta model element	ConsistencyNeeds	1	

**Table 3.175: Consistency Needs**

### 3.4.3 Tools

#### 3.4.3.1 Component API Generator Tool

<b>Tool</b>	<b>Component API Generator Tool</b>		
<b>Package</b>	AUTOSAR Root::M2::Methodology::Methodology Library::Component::Guidance		
<b>Brief Description</b>	Generates the software component contract header used to connect the software component to the RTE layer.		
<b>Description</b>	<p>This guidance represents the so-called contract phase of the RTE generation process.</p> <ul style="list-style-type: none"> <li>• SWC Contract phase - a limited set of information about a component, principally the AUTOSAR Interface definitions and the internal behavior, is used to create an application header file for a component type. The application header file defines the "contract" between component and RTE.</li> <li>• BSW Contract phase - a similar use case for a BSW module in order to generate the module interlink header files, which are used to interface between the module and the BSW Scheduler.</li> <li>• Additional phases - for SWS and BSW as well - are used to bind pre-build variants in the contract headers of a single Software Component or BSW module.</li> </ul>		
<b>Kind</b>			
<b>Relation Type</b>	<b>Related Element</b>	<b>Mul.</b>	<b>Note</b>
Used	Generate Atomic Software Component Contract Header Files	1	
Used	Generate BSW Module Prebuild Data Set	1	
Used	Generate BSWM Contract Header Files	1	
Used	Generate Component Header File in Vendor Mode	1	
Used	Generate Component Prebuild Data Set	1	

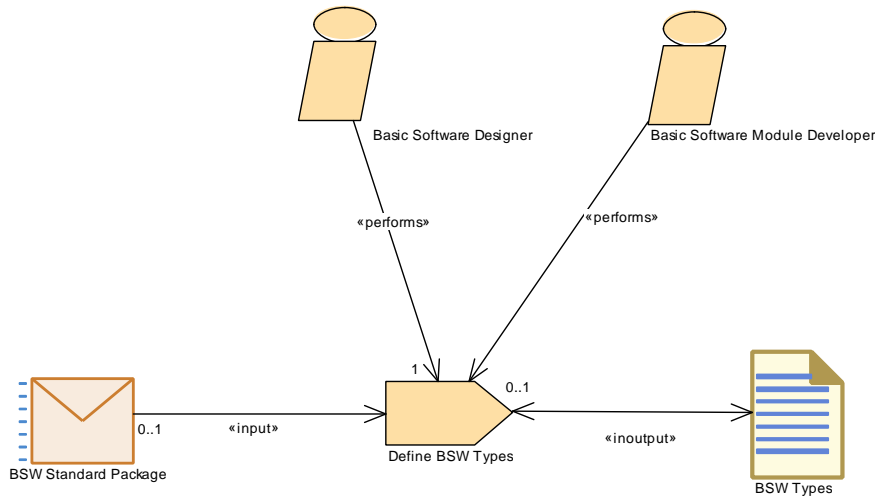
**Table 3.176: Component API Generator Tool**

### 3.5 Basic Software

This chapter contains the definition of work products and tasks used for the development of Basic Software modules. For the definition of the relevant meta-model elements refer to [5].

### 3.5.1 Tasks

#### 3.5.1.1 Define BSW Types

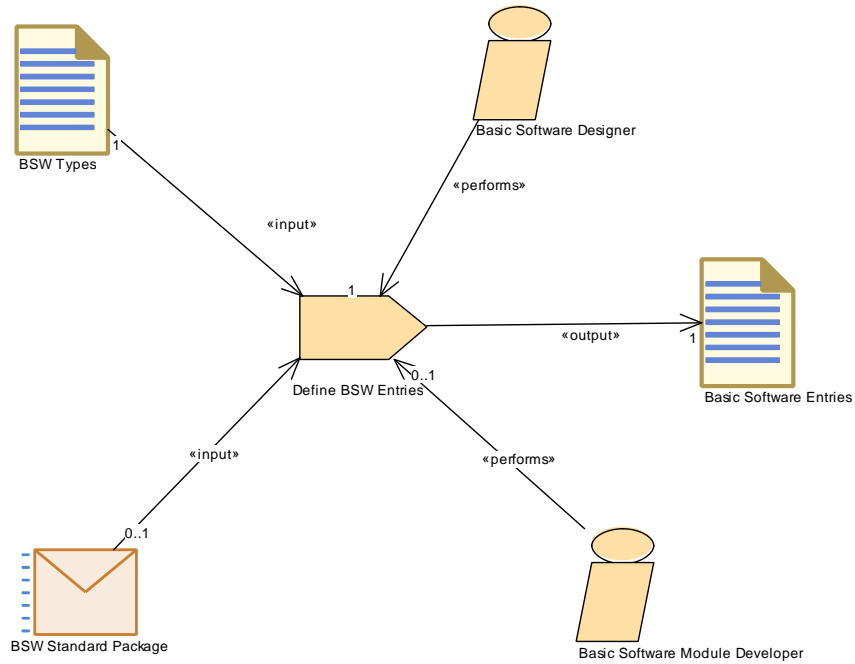


**Figure 3.85: Define BSW Types**

<b>Task Definition</b>	<b>Define BSW Types</b>		
<b>Package</b>	AUTOSAR Root::M2::Methodology::Methodology Library::Bsw::Tasks		
<b>Brief Description</b>	Define data types for usage within the Basic Software.		
<b>Description</b>	A data type is typically based on elements standardized by AUTOSAR, therefore BSW Standard Package appears as a mandatory input.		
<b>Relation Type</b>	<b>Related Element</b>	<b>Mul.</b>	<b>Note</b>
Performed by	Basic Software Designer	1	
Performed by	Basic Software Module Developer	1	
Consumes	BSW Standard Package	0..1	
In/out	BSW Types	1	

**Table 3.177: Define BSW Types**

**3.5.1.2 Define BSW Entries**

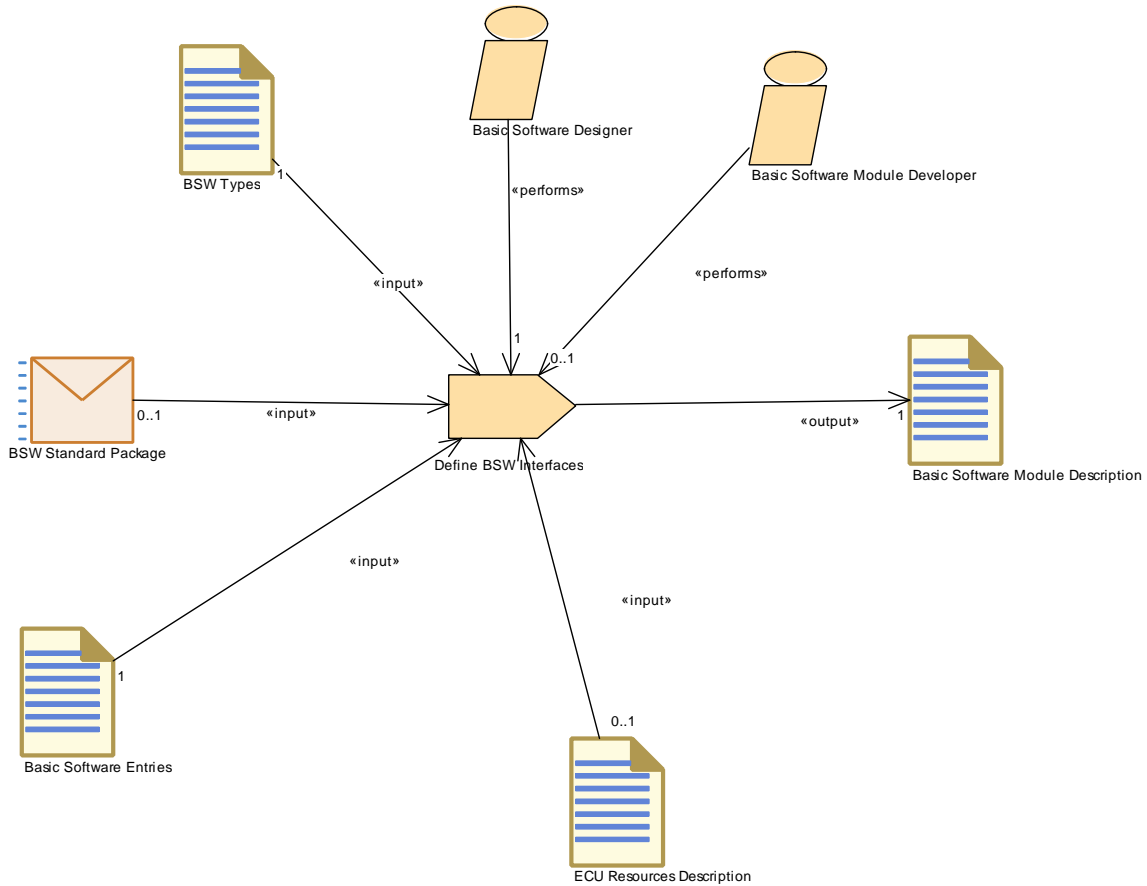


**Figure 3.86: Define BSW Entries**

<b>Task Definition</b>	<b>Define BSW Entries</b>		
<b>Package</b>	AUTOSAR Root::M2::Methodology::Methodology Library::Bsw::Tasks		
<b>Brief Description</b>	Define BswEntries (= function signatures) for usage within the Basic Software.		
<b>Description</b>			
<b>Relation Type</b>	<b>Related Element</b>	<b>Mul.</b>	<b>Note</b>
Performed by	Basic Software Designer	1	
Performed by	Basic Software Module Developer	1	
Consumes	BSW Types	1	
Consumes	BSW Standard Package	0..1	
Produces	Basic Software Entries	1	

**Table 3.178: Define BSW Entries**

**3.5.1.3 Define BSW Interfaces**



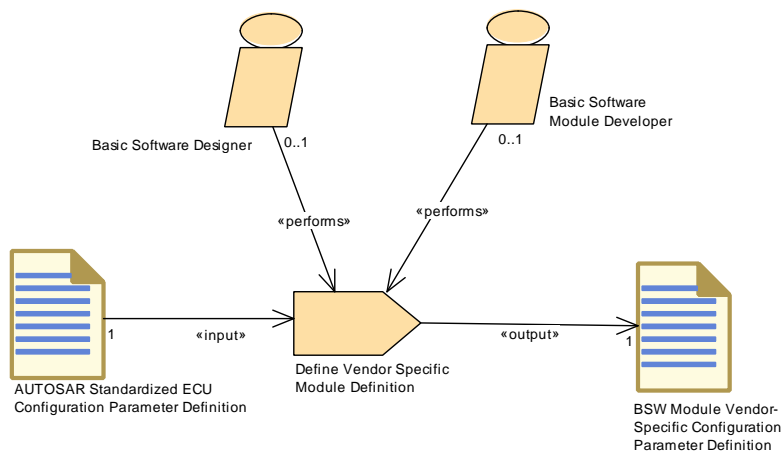
**Figure 3.87: Define BSW Interfaces**

<b>Task Definition</b>	<b>Define BSW Interfaces</b>		
<b>Package</b>	AUTOSAR Root::M2::Methodology::Methodology Library::Bsw::Tasks		
<b>Brief Description</b>	Define the interfaces for a single BSW Module.		
<b>Description</b>	Define the interfaces for a particular BSW Module or cluster as part of the BSW Module Description. This includes an abstraction of the required and provided C-functions, as well as triggers and modes. Note that this task also exists for modules standardized by AUTOSAR, as it may be required to decide on optional or alternative elements and to add allowed project specific extensions.		
<b>Relation Type</b>	<b>Related Element</b>	<b>Mul.</b>	<b>Note</b>
Performed by	Basic Software Designer	1	
Performed by	Basic Software Module Developer	1	
Consumes	BSW Types	1	
Consumes	Basic Software Entries	1	
Consumes	BSW Standard Package	0..1	

Relation Type	Related Element	Mul.	Note
Consumes	ECU Resources Description	0..1	
Produces	Basic Software Module Description	1	

**Table 3.179: Define BSW Interfaces**

### 3.5.1.4 Define Vendor Specific Module Definition

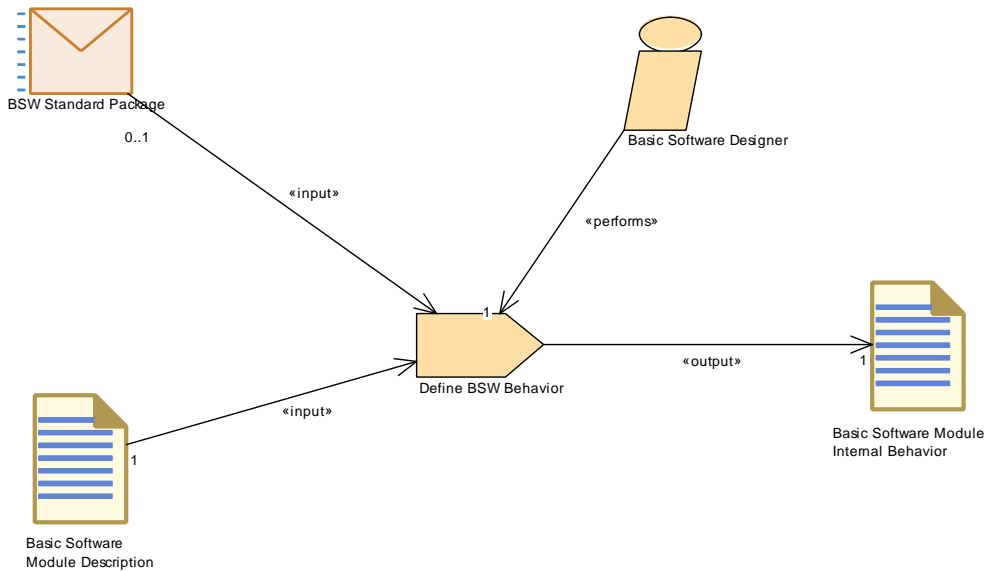


**Figure 3.88: Define Vendor Specific Module Definition**

Task Definition	Define Vendor Specific Module Definition		
Package	AUTOSAR Root::M2::Methodology::Methodology Library::Bsw::Tasks		
Brief Description			
Description	Define the Vendor Specific Module Definition (=Configuration Parameters).		
Relation Type	Related Element	Mul.	Note
Performed by	Basic Software Designer	0..1	
Performed by	Basic Software Module Developer	0..1	
Consumes	AUTOSAR Standardized ECU Configuration Parameter Definition	1	
Produces	BSW Module Vendor-Specific Configuration Parameter Definition	1	

**Table 3.180: Define Vendor Specific Module Definition**

**3.5.1.5 Define BSW Behavior**

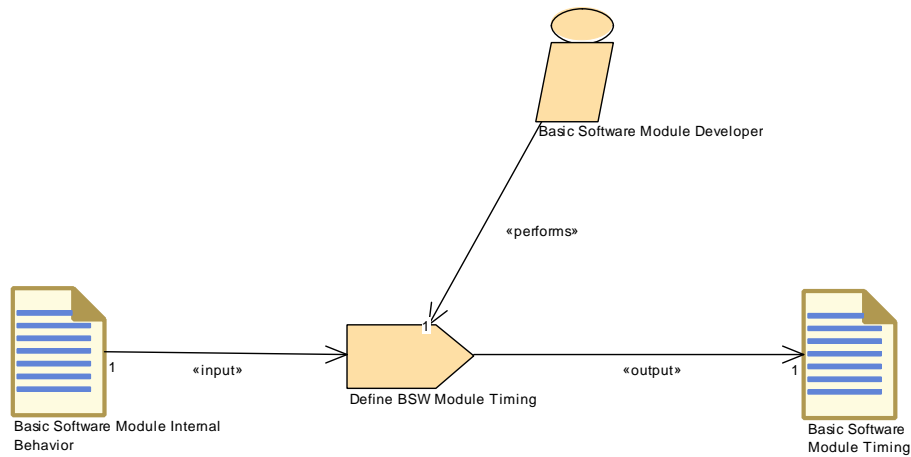


**Figure 3.89: Define BSW Behavior**

<b>Task Definition</b>	<b>Define BSW Behavior</b>		
<b>Package</b>	AUTOSAR Root::M2::Methodology::Methodology Library::Bsw::Tasks		
<b>Brief Description</b>	Define the BSW Behavior related to a BSW Module Description.		
<b>Description</b>	Define the BSW Behavior related to a BSW Module Description. This task is required during BSW module development in order to be able to generate the API to the BSW Scheduler. In addition, local data (variables or parameters) may be defined during this task in order to use the AUTOSAR data type system for module local data and to generate measurement & calibration support.		
<b>Relation Type</b>	<b>Related Element</b>	<b>Mul.</b>	<b>Note</b>
Performed by	Basic Software Designer	1	
Consumes	Basic Software Module Description	1	
Consumes	BSW Standard Package	0..1	
Produces	Basic Software Module Internal Behavior	1	

**Table 3.181: Define BSW Behavior**

### 3.5.1.6 Define BSW Module Timing



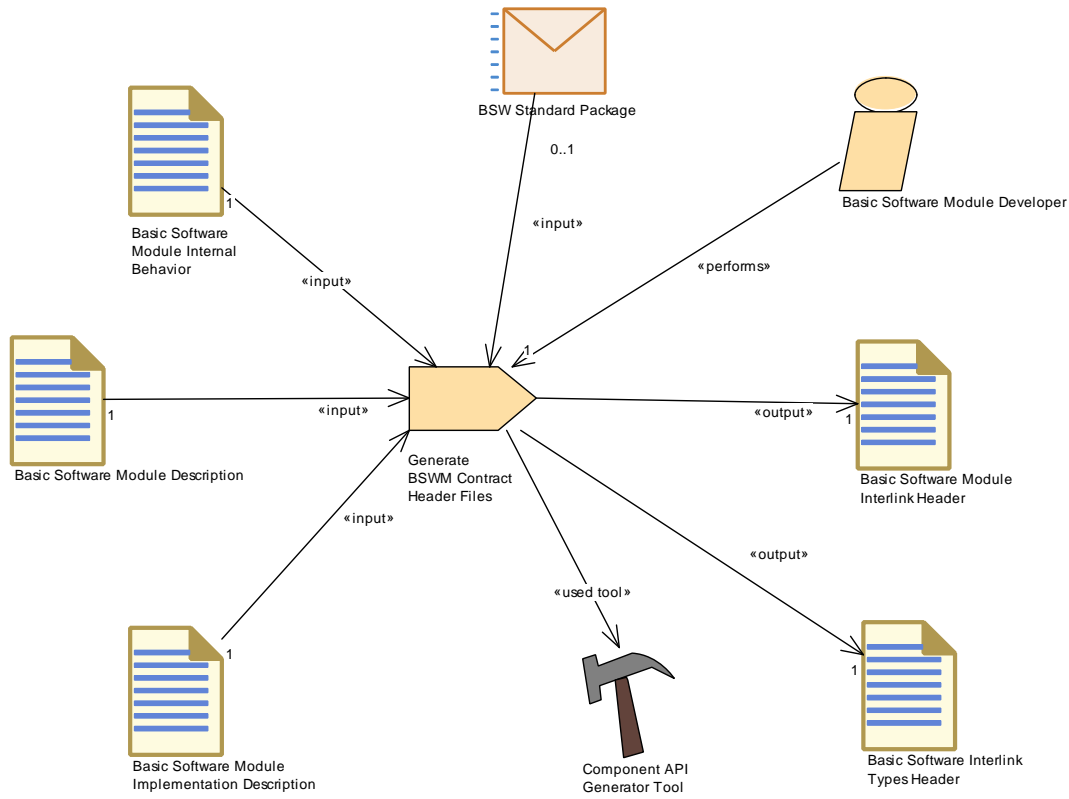
**Figure 3.90: Define BSW Module Timing**

<b>Task Definition</b>	<b>Define BSW Module Timing</b>		
<b>Package</b>	AUTOSAR Root::M2::Methodology::Methodology Library::Bsw::Tasks		
<b>Brief Description</b>	Define BSWModuleTiming (TimingDescription and TimingConstraints) for the Internal Behavior (BSWModuleEntities) of a BSW module		
<b>Description</b>	Define BSWModuleTiming (TimingDescription and TimingConstraints) for the Internal Behavior (BSWModuleEntities) of a BSW module		
<b>Relation Type</b>	<b>Related Element</b>	<b>Mul.</b>	<b>Note</b>
Performed by	Basic Software Module Developer	1	
Consumes	Basic Software Module Internal Behavior	1	
Produces	Basic Software Module Timing	1	

**Table 3.182: Define BSW Module Timing**



**3.5.1.7 Generate BSW Contract Header Files**



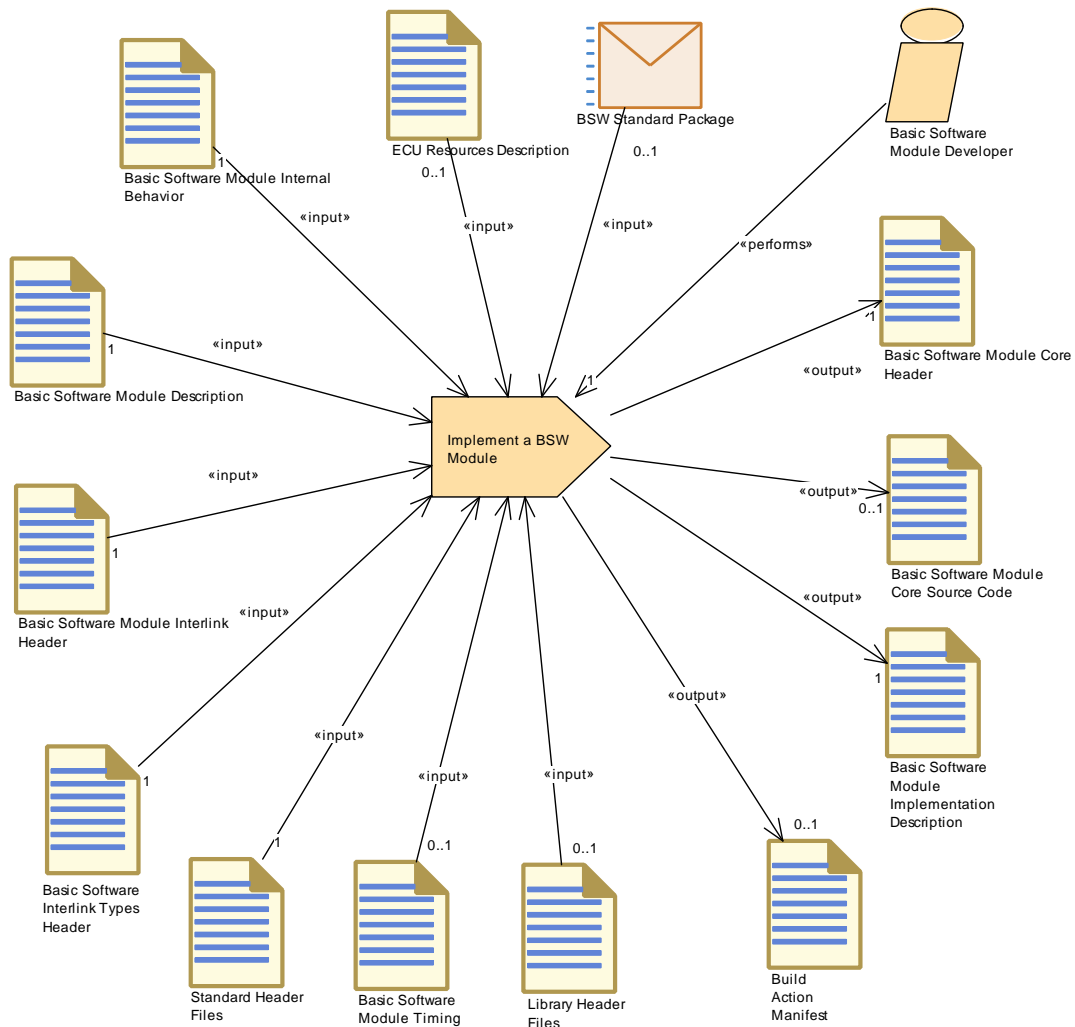
**Figure 3.91: Generate BSW Contract Header Files**

<b>Task Definition</b>	<b>Generate BSWM Contract Header Files</b>		
<b>Package</b>	AUTOSAR Root::M2::Methodology::Methodology Library::Bsw::Tasks		
<b>Brief Description</b>	Generate Basic Softwaree Module Contract Header Files		
<b>Description</b>	Generate the header files needed for a BSW module as part of the so-called "contract phase". These headers will allow to link the module lateron with the RTE (namely the BSW Scheduler).  Meth.bindingTime = CodeGenerationTime		
<b>Relation Type</b>	<b>Related Element</b>	<b>Mul.</b>	<b>Note</b>
Performed by	Basic Software Module Developer	1	
Consumes	Basic Software Module Description	1	Meth.bindingTime = SystemDesignTime
Consumes	Basic Software Module Implementation Description	1	Meth.bindingTime = SystemDesignTime
Consumes	Basic Software Module Internal Behavior	1	Meth.bindingTime = SystemDesignTime
Consumes	BSW Standard Package	0..1	

Relation Type	Related Element	Mul.	Note
Produces	Basic Software Interlink Header	1	Meth.bindingTime = CodeGenerationTime
Produces	Basic Software Module Interlink Header	1	Meth.bindingTime = CodeGenerationTime
Used tool	Component API Generator Tool	1	

**Table 3.183: Generate BSWM Contract Header Files**

### 3.5.1.8 Implement a BSW Module



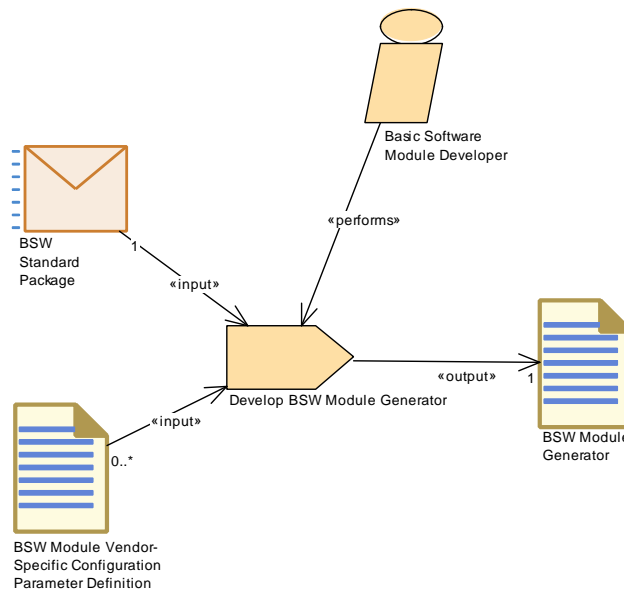
**Figure 3.92: Implement a BSW Module**

<b>Task Definition</b>	<b>Implement a BSW Module</b>		
<b>Package</b>	AUTOSAR Root::M2::Methodology::Methodology Library::Bsw::Tasks		
<b>Brief Description</b>	Implement the source code of a BSW module.		
<b>Description</b>	<p>Implement the source code of a BSW module. This task is not described by AUTOSAR completely, but included for completeness of the AUTOSAR use cases. Note that specification of an AUTOSAR standard module imposes several requirements, e.g. the inclusion of certain header files, onto this task.</p> <p>In addition to the code, this task also produces the necessary XML descriptions.</p> <p>Optionally, a build action manifest may be created or modified in order to be used for code generation or further processing of the code.</p> <p>Meth.bindingTime = CodeGenerationTime</p>		
<b>Relation Type</b>	<b>Related Element</b>	<b>Mul.</b>	<b>Note</b>
Performed by	Basic Software Module Developer	1	
Consumes	Basic Software Interlink Types Header	1	Meth.bindingTime = SystemDesignTime
Consumes	Basic Software Module Description	1	Meth.bindingTime = SystemDesignTime
Consumes	Basic Software Module Interlink Header	1	Meth.bindingTime = SystemDesignTime
Consumes	Basic Software Module Internal Behavior	1	Meth.bindingTime = SystemDesignTime
Consumes	Standard Header Files	1	Meth.bindingTime = CodeGenerationTime
Consumes	BSW Standard Package	0..1	
Consumes	Basic Software Module Timing	0..1	Meth.bindingTime = SystemDesignTime
Consumes	ECU Resources Description	0..1	Meth.bindingTime = SystemDesignTime
Consumes	Library Header Files	0..1	Meth.bindingTime = CodeGenerationTime
Produces	Basic Software Module Core Header	1	Meth.bindingTime = CodeGenerationTime
Produces	Basic Software Module Implementation Description	1	Meth.bindingTime = CodeGenerationTime

Relation Type	Related Element	Mul.	Note
Produces	Basic Software Module Core Source Code	0..1	The creation of source code is optional, since it might be generated completely in a later step based on the Build Action Manifest. Meth.bindingTime = CodeGenerationTime
Produces	Build Action Manifest	0..1	

**Table 3.184: Implement a BSW Module**

### 3.5.1.9 Develop BSW Module Generator



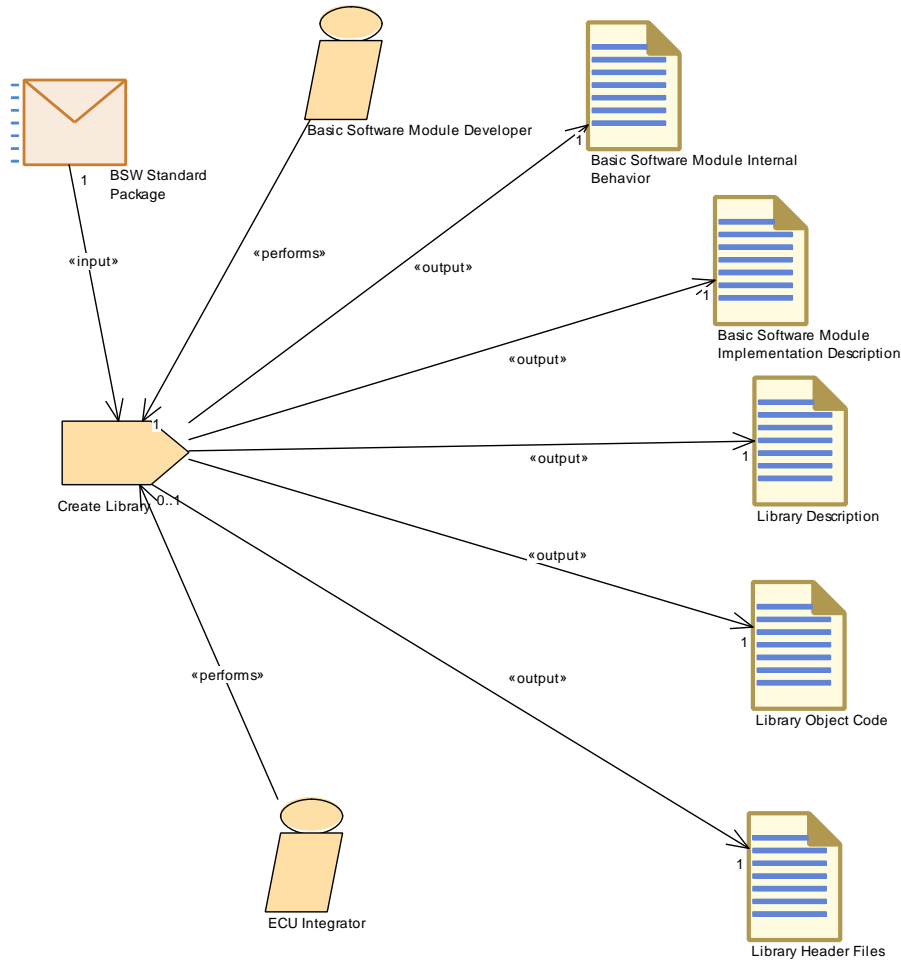
**Figure 3.93: Develop BSW Module Generator**

Task Definition	Develop BSW Module Generator		
Package	AUTOSAR Root::M2::Methodology::Methodology Library::Bsw::Tasks		
Brief Description			
Description	Develop a generator for one or more BSW modules.		
Relation Type	Related Element	Mul.	Note
Performed by	Basic Software Module Developer	1	
Consumes	BSW Standard Package	1	
Consumes	BSW Module Vendor-Specific Configuration Parameter Definition	0..*	
Produces	BSW Module Generator	1	

Relation Type	Related Element	Mul.	Note
---------------	-----------------	------	------

**Table 3.185: Develop BSW Module Generator**

**3.5.1.10 Create Library**



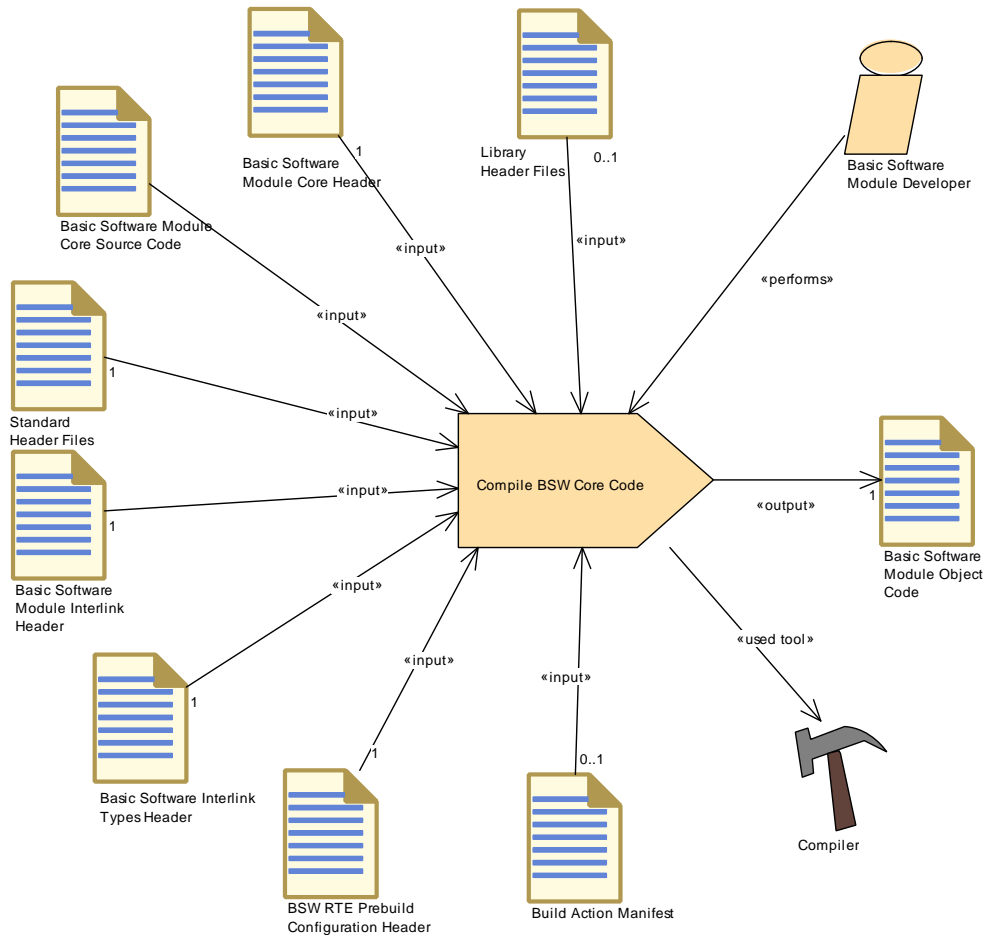
**Figure 3.94: Create Library**

<b>Task Definition</b>	<b>Create Library</b>
<b>Package</b>	AUTOSAR Root::M2::Methodology::Methodology Library::Bsw::Tasks
<b>Brief Description</b>	Create a library to be used within an Autosar ECU.
<b>Description</b>	Create a non-standardized library to be used within an Autosar ECU. The task is the same for the basic software and application level, but it is considered as a basic software task because no VFB resp. RTE abstraction is used. The output includes source code, header file and XML descriptions of the interfaces and of the implementation. A "dummy" BSW Behavior must be created too in order to be able to link the other two XML artifacts.  Meth.bindingTime = CodeGenerationTime
<b>Relation Type</b>	<b>Related Element</b> <b>Mul.</b> <b>Note</b>

<i>Relation Type</i>	<i>Related Element</i>	<i>Mul.</i>	<i>Note</i>
Performed by	Basic Software Module Developer	1	
Performed by	ECU Integrator	1	
Consumes	BSW Standard Package	1	Used for standard types and specifications.
Produces	Basic Software Module Implementation Description	1	Meth.bindingTime = CodeGenerationTime
Produces	Basic Software Module Internal Behavior	1	Meth.bindingTime = CodeGenerationTime
Produces	Library Description	1	Meth.bindingTime = CodeGenerationTime
Produces	Library Header Files	1	Meth.bindingTime = CodeGenerationTime
Produces	Library Object Code	1	Meth.bindingTime = CodeGenerationTime

**Table 3.186: Create Library**

### 3.5.1.11 Compile BSW Core Code



**Figure 3.95: Compile BSW Core Code**

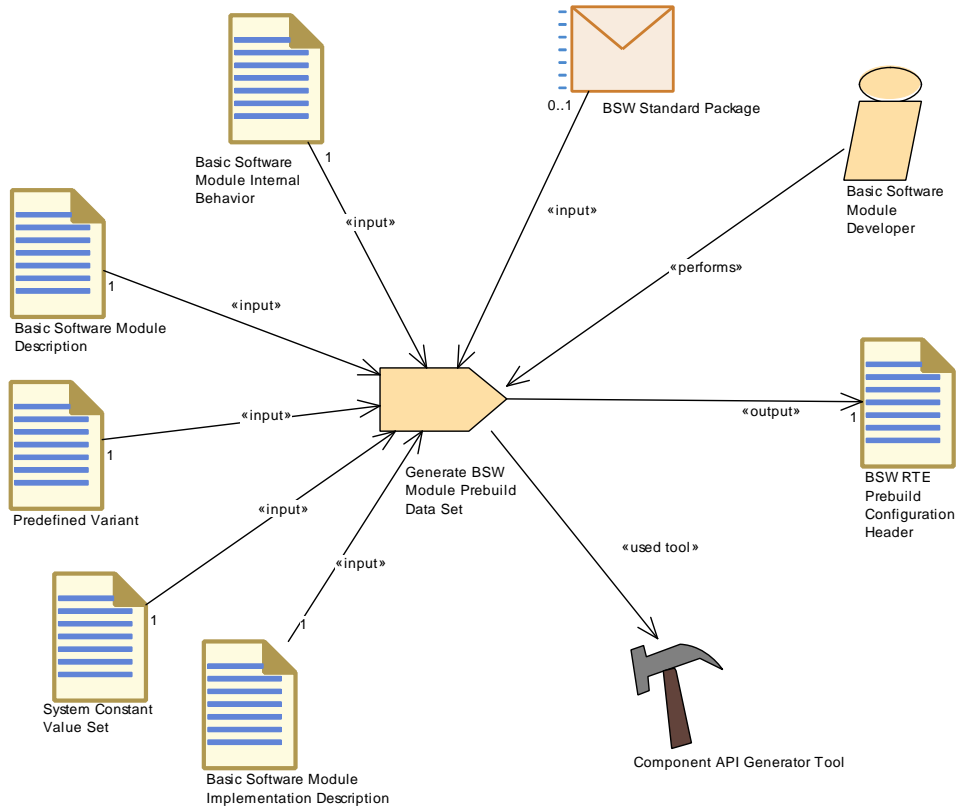
<b>Task Definition</b>	<b>Compile BSW Core Code</b>		
<b>Package</b>	AUTOSAR Root::M2::Methodology::Methodology Library::Bsw::Tasks		
<b>Brief Description</b>	Compile the source code of a BSW module without ECU specific configurations.		
<b>Description</b>	<p>Compile the source code of a BSW module without ECU specific configurations. This task is mainly used to describe the use cases of BSW development for object code delivery. The output will only represent the "core code". During ECU integration, additional generated code may be added per module in response to ECU configuration.</p> <p>Meth.bindingTime = CompileTime</p>		
<b>Relation Type</b>	<b>Related Element</b>	<b>Mul.</b>	<b>Note</b>
Performed by	Basic Software Module Developer	1	
Consumes	BSW RTE Pre-build Configuration Header	1	Meth.bindingTime = PreCompileTime

<b>Relation Type</b>	<b>Related Element</b>	<b>Mul.</b>	<b>Note</b>
Consumes	BSW Types	1	Meth.bindingTime = CodeGenerationTime
Consumes	Basic Software Interlink Types Header	1	Meth.bindingTime = CodeGenerationTime
Consumes	Basic Software Module Core Header	1	Meth.bindingTime = CodeGenerationTime
Consumes	Basic Software Module Core Source Code	1	Meth.bindingTime = CodeGenerationTime
Consumes	Basic Software Module Interlink Header	1	Meth.bindingTime = CodeGenerationTime
Consumes	Standard Header Files	1	Meth.bindingTime = CodeGenerationTime
Consumes	Build Action Manifest	0..1	The compilation can optionally be controlled by a Build Action Manifest.
Consumes	Library Header Files	0..1	Meth.bindingTime = CodeGenerationTime
Produces	Basic Software Module Object Code	1	Meth.bindingTime = CompileTime
Used tool	Compiler	1	

**Table 3.187: Compile BSW Core Code**



**3.5.1.12 Generate BSW Module Prebuild Dataset**



**Figure 3.96: Generate BSW Module Prebuild Dataset**

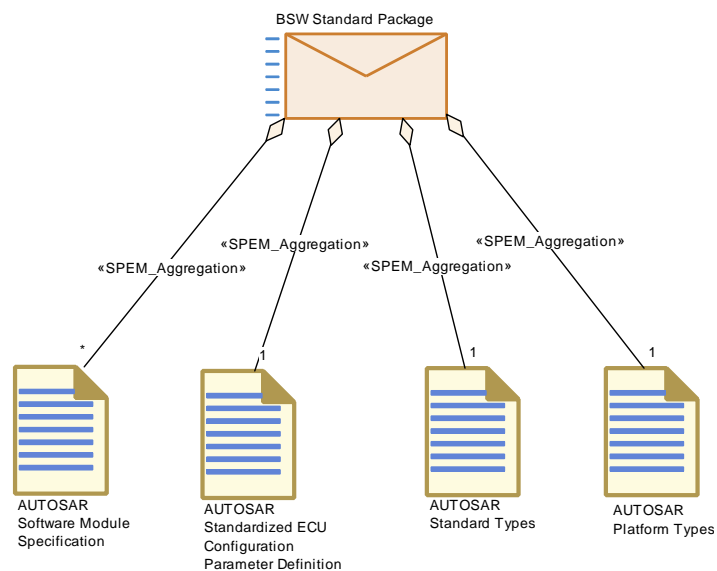
<b>Task Definition</b>	<b>Generate BSW Module Prebuild Data Set</b>		
<b>Package</b>	AUTOSAR Root::M2::Methodology::Methodology Library::Bsw::Tasks		
<b>Brief Description</b>	Prebuild Data Set Generation Phase for a BSW module: It binds all variations which need to be set after generation of the RTE contract header but before compilation of the module.		
<b>Description</b>	<p>Prebuild Data Set Generation Phase for a basic software module: It binds all variations which need to be set after generation of the RTE contract header but before compilation of the module. The variant settings must be defined by the PredefinedVariant given as input.</p> <p>The output is a BSW Module RTE Prebuild Configuration Header which is included by the corresponding BSW Module Interlink Header, thereby resolving the variation points when compiled. Note that link time variants are not allowed here.</p> <p>Meth.bindingTime = PreCompileTime</p>		
<b>Relation Type</b>	<b>Related Element</b>	<b>Mul.</b>	<b>Note</b>
Performed by	Basic Software Module Developer	1	
Consumes	Basic Software Module Description	1	Meth.bindingTime = CodeGenerationTime

Relation Type	Related Element	Mul.	Note
Consumes	Basic Software Module Implementation Description	1	Meth.bindingTime = CodeGenerationTime
Consumes	Basic Software Module Internal Behavior	1	Meth.bindingTime = CodeGenerationTime
Consumes	Predefined Variant	1	
Consumes	System Constant Value Set	1	
Consumes	BSW Standard Package	0..1	
Produces	BSW RTE Pre-build Configuration Header	1	Meth.bindingTime = PreCompileTime
Used tool	Component API Generator Tool	1	

**Table 3.188: Generate BSW Module Prebuild Data Set**

### 3.5.2 Work Products

#### 3.5.2.1 BSW Standard Package

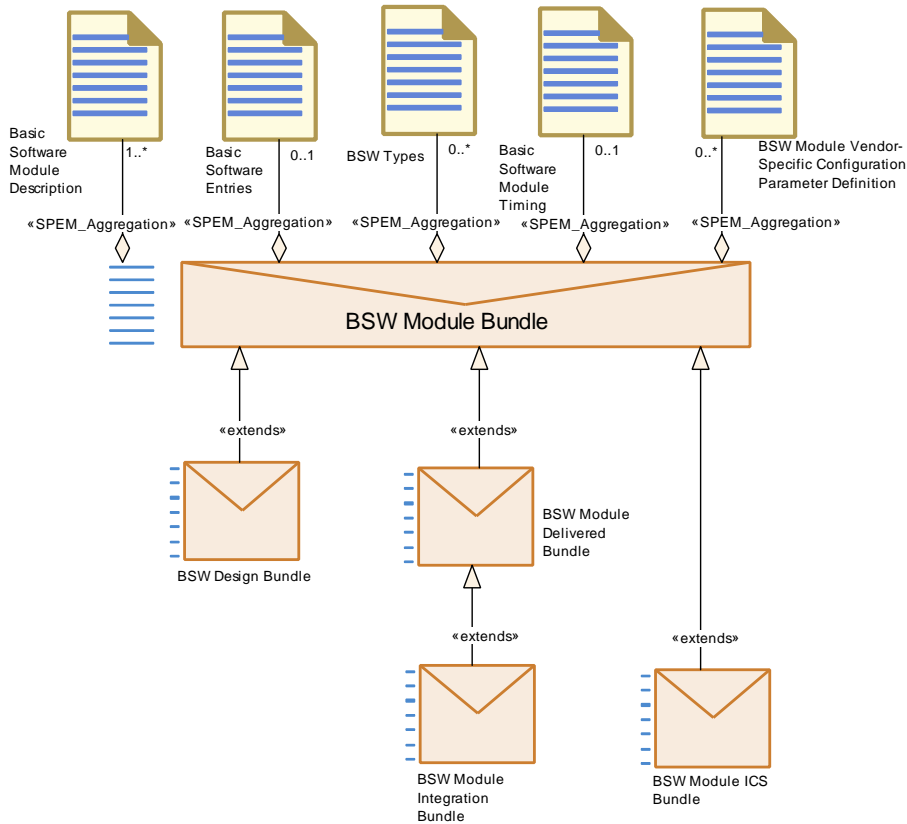


**Figure 3.97: BSW Standard Package**

<b>Deliverable</b>	<b>BSW Standard Package</b>		
<b>Package</b>	AUTOSAR Root::M2::Methodology::Methodology Library::Bsw::Work products		
<b>Brief Description</b>	Package containing standard artifacts for BSW.		
<b>Description</b>	<p>Contains the standard specifications and standard ARXML artifacts to be used within the AUTOSAR basic software and for the generation of the RTE.</p> <p>This deliverable is released by AUTOSAR and is readonly within the methodology.</p>		
<b>Kind</b>	Delivered		
<b>Relation Type</b>	<b>Related Element</b>	<b>Mul.</b>	<b>Note</b>
Aggregates	AUTOSAR Platform Types	1	
Aggregates	AUTOSAR Standard Types	1	
Aggregates	AUTOSAR Standardized ECU Configuration Parameter Definition	1	
Aggregates	AUTOSAR Software Module Specification	0..*	
Consumed by	Create Library	1	Used for standard types and specifications.
Consumed by	Design Basic Software	1	
Consumed by	Develop BSW Module	1	
Consumed by	Develop BSW Module Generator	1	
Consumed by	Develop Basic Software	1	
Consumed by	Define BSW Behavior	0..1	
Consumed by	Define BSW Entries	0..1	
Consumed by	Define BSW Interfaces	0..1	
Consumed by	Define BSW Types	0..1	
Consumed by	Generate BSW Module Prebuild Data Set	0..1	
Consumed by	Generate BSWM Contract Header Files	0..1	
Consumed by	Implement a BSW Module	0..1	

**Table 3.189: BSW Standard Package**

### 3.5.2.2 BSW Module Bundle



**Figure 3.98: BSW Module Bundle**

<b>Deliverable</b>	<b>BSW Module Bundle</b>		
<b>Package</b>	AUTOSAR Root::M2::Methodology::Methodology Library::Bsw::Work products		
<b>Brief Description</b>			
<b>Description</b>	<p>Generic deliverable representing a bundle of one or more BSW modules. It is used as a basis for extended deliverables.</p> <p>The deliverable aggregates the ARXML definitions on the interface level including vendor specific configuration parameter definition.</p> <p>According to the role of the extended deliverable, these elements maybe blueprints completely or partially. .</p>		
<b>Kind</b>	Delivered		
<b>Extended by</b>	BSW Design Bundle, BSW Module Delivered Bundle, BSW Module IC S Bundle		
<b>Relation Type</b>	<b>Related Element</b>	<b>Mul.</b>	<b>Note</b>
Aggregates	Basic Software Module Description	1..*	
Aggregates	Basic Software Entries	0..1	

<i>Relation Type</i>	<i>Related Element</i>	<i>Mul.</i>	<i>Note</i>
Aggregates	<a href="#">Basic Software Module Timing</a>	0..1	
Aggregates	<a href="#">BSW Module Vendor-Specific Configuration Parameter Definition</a>	0..*	The configuration parameter definitions of the modules under test - needed for static check against the standardized configuration parameters.
Aggregates	<a href="#">BSW Types</a>	0..*	

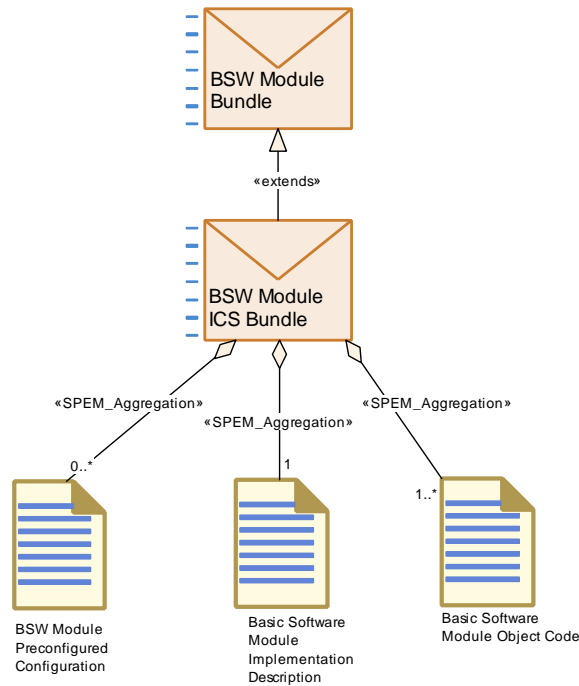
**Table 3.190: BSW Module Bundle**

### 3.5.2.3 BSW Design Bundle

<i>Deliverable</i>	<b>BSW Design Bundle</b>		
<i>Package</i>	AUTOSAR Root::M2::Methodology::Methodology Library::Bsw::Work products		
<i>Brief Description</i>			
<i>Description</i>	A bundle of one or more BSW modules used in the design phase.  It contains only definitions on the interface level. These elements maybe blueprints completely or partially.		
<i>Kind</i>	Delivered		
<i>Extends</i>	<a href="#">BSW Module Bundle</a>		
<i>Relation Type</i>	<i>Related Element</i>	<i>Mul.</i>	<i>Note</i>
Produced by	<a href="#">Design Basic Software</a>	1..*	
Consumed by	<a href="#">Develop BSW Module</a>	1..*	

**Table 3.191: BSW Design Bundle**

**3.5.2.4 BSW Module ICS Bundle**

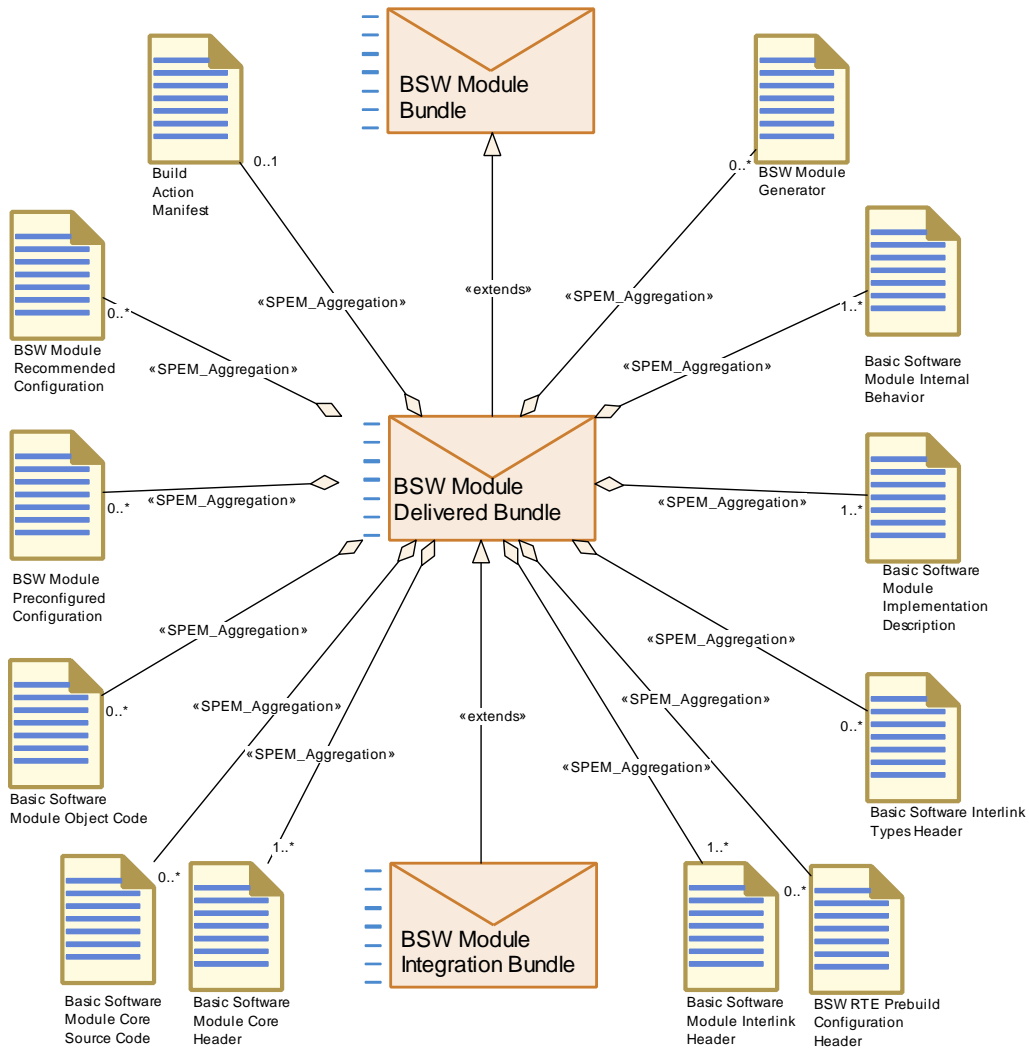


**Figure 3.99: BSW Module ICS Bundle**

<b>Deliverable</b>	<b>BSW Module ICS Bundle</b>		
<b>Package</b>	AUTOSAR Root::M2::Methodology::Methodology Library::Bsw::Work products		
<b>Brief Description</b>			
<b>Description</b>	Deliverable containing the Implementation Conformance Statement (ICS) for one or more BSW modules.		
<b>Kind</b>	Delivered		
<b>Extends</b>	<a href="#">BSW Module Bundle</a>		
<b>Relation Type</b>	<b>Related Element</b>	<b>Mul.</b>	<b>Note</b>
Aggregates	<a href="#">Basic Software Module Implementation Description</a>	1	The administrative elements (e.g. version info) of the Implementation model needed for the conformance test.
Aggregates	<a href="#">Basic Software Module Object Code</a>	1..*	
Aggregates	<a href="#">BSW Module Preconfigured Configuration</a>	0..*	The predefined configurations implemented by the modules under test. The modules under test are completely configured.

**Table 3.192: BSW Module ICS Bundle**

### 3.5.2.5 BSW Module Delivered Bundle



**Figure 3.100: BSW Module Delivered Bundle**

<b>Deliverable</b>	<b>BSW Module Delivered Bundle</b>		
<b>Package</b>	AUTOSAR Root::M2::Methodology::Methodology Library::Bsw::Work products		
<b>Brief Description</b>			
<b>Description</b>	Deliverable containing one or more BSW modules delivered for integration (code and ARXML descriptions).  It can still contain blueprints for some of the elements which need to be extended during ECU integration.		
<b>Kind</b>	Delivered		
<b>Extended by</b>	<a href="#">BSW Module Integration Bundle</a>		
<b>Extends</b>	<a href="#">BSW Module Bundle</a>		
<b>Relation Type</b>	<b>Related Element</b>	<b>Mul.</b>	<b>Note</b>

<b>Relation Type</b>	<b>Related Element</b>	<b>Mul.</b>	<b>Note</b>
Aggregates	Basic Software Module Core Header	1..*	
Aggregates	Basic Software Module Implemen- tation Description	1..*	
Aggregates	Basic Software Module Interlink Header	1..*	
Aggregates	Basic Software Module Internal Behavior	1..*	
Aggregates	Build Action Mani- fest	0..1	The build action manifest to be used for the delivered basic software.
Aggregates	BSW Module Gen- erator	0..*	
Aggregates	BSW Module Pre- configured Config- uration	0..*	
Aggregates	BSW Module Recommended Configuration	0..*	
Aggregates	BSW RTE Pre- build Configuration Header	0..*	
Aggregates	Basic Software Interlink Types Header	0..*	
Aggregates	Basic Software Module Core Source Code	0..*	
Aggregates	Basic Software Module Object Code	0..*	
Produced by	Develop BSW Module	1	
Produced by	Develop Basic Software	1..*	
Consumed by	Define Integration Variant	1..*	
Consumed by	Generate Base Ecu Configuration	1..*	Need vendor specific configuration parameters and their recommended or pre-configured values.
Consumed by	Integrate Software for ECU	1..*	
Consumed by	Prepare ECU Con- figuration	1..*	
Consumed by	Configure Com	0..1	



<b>Relation Type</b>	<b>Related Element</b>	<b>Mul.</b>	<b>Note</b>
Consumed by	<a href="#">Configure Diagnostics</a>	0..1	Predefined or recommended configuration values, vendor specific parameters, ServiceNeeds defined by BSW.
Consumed by	<a href="#">Configure MCAL</a>	0..1	
Consumed by	<a href="#">Configure Mode Management</a>	0..1	Predefined or recommended configuration values, vendor specific parameters, ServiceNeeds defined by BSW.
Consumed by	<a href="#">Configure NvM</a>	0..1	Predefined or recommended configuration values, vendor specific parameters, ServiceNeeds defined by BSW.
Consumed by	<a href="#">Configure Watchdog Manager</a>	0..1	Predefined or recommended configuration values, vendor specific parameters, ServiceNeeds defined by BSW.
Consumed by	<a href="#">Create Service Component</a>	0..1	Required in order to define a mapping between SWC and BSW.  In addition, the Build Action Manifest may be used.
Consumed by	<a href="#">Configure Debug</a>	0..*	
Consumed by	<a href="#">Configure ECUC</a>	0..*	
Consumed by	<a href="#">Configure IO Hardware abstraction</a>	0..*	
Consumed by	<a href="#">Configure OS</a>	0..*	OS Resources required by Basic Software.  Optional Input: Basic Software Module Timing, e.g. execution order constraints.
Consumed by	<a href="#">Configure RTE</a>	0..*	Input from the BSW Module Description is needed related to Scheduling, Exclusive Areas, Triggers and Modes.  Optional Input: Basic Software Module Timing, e.g. execution order constraints.

**Table 3.193: BSW Module Delivered Bundle**

### 3.5.2.6 AUTOSAR Software Module Specification

<b>Artifact</b>	<b>AUTOSAR Software Module Specification</b>		
<b>Package</b>	AUTOSAR Root::M2::Methodology::Methodology Library::Bsw::Work products		
<b>Brief Description</b>	The standard software module specification.		
<b>Description</b>	<p>Specification of a standardized Basic Software Module (SWS).</p> <p>It is published as a textual specification, but can be seen as a Basic Software Design bundle in the methodology, consisting mainly of blueprints. It may be published as ARXML in future releases of AUTOSAR.</p>		
<b>Kind</b>	Text		
<b>Relation Type</b>	<b>Related Element</b>	<b>Mul.</b>	<b>Note</b>
Aggregated by	<a href="#">BSW Standard Package</a>	0..*	

**Table 3.194: AUTOSAR Software Module Specification**

### 3.5.2.7 AUTOSAR Standard Types

<b>Artifact</b>	<b>AUTOSAR Standard Types</b>		
<b>Package</b>	AUTOSAR Root::M2::Methodology::Methodology Library::Bsw::Work products		
<b>Brief Description</b>	Contains all the standardized module definition parameters.		
<b>Description</b>	ARXML description of the AUTOSAR standard types (e.g. Std_ReturnType).		
<b>Kind</b>	AUTOSAR XML		
<b>Relation Type</b>	<b>Related Element</b>	<b>Mul.</b>	<b>Note</b>
Aggregated by	<a href="#">BSW Standard Package</a>	1	
Aggregated by	<a href="#">VFB AUTOSAR Standard Package</a>	1	
Use meta model element	Implementation DataType	1	

**Table 3.195: AUTOSAR Standard Types**

### 3.5.2.8 AUTOSAR Platform Types

<b>Artifact</b>	<b>AUTOSAR Platform Types</b>		
<b>Package</b>	AUTOSAR Root::M2::Methodology::Methodology Library::Bsw::Work products		
<b>Brief Description</b>	Contains all the standardized module definition parameters.		
<b>Description</b>	<p>ARXML description of the standardized part of the AUTOSAR platform types. It consists of</p> <ul style="list-style-type: none"> <li>• ImplementationDataTypes for the platform types - this part is still platform independent.</li> <li>• Blueprints of the underlying BaseTypes. These have to be refined for each processor platform.</li> </ul>		
<b>Kind</b>	AUTOSAR XML		
<b>Relation Type</b>	<b>Related Element</b>	<b>Mul.</b>	<b>Note</b>
Aggregated by	<a href="#">BSW Standard Package</a>	1	
Aggregated by	<a href="#">VFB AUTOSAR Standard Package</a>	1	
Use meta model element	Implementation DataType	1	
Use meta model element	SwBaseType	1	

**Table 3.196: AUTOSAR Platform Types**

### 3.5.2.9 BSW Module Generator

<b>Artifact</b>	<b>BSW Module Generator</b>		
<b>Package</b>	AUTOSAR Root::M2::Methodology::Methodology Library::Bsw::Work products		
<b>Brief Description</b>			
<b>Description</b>	A generator that comes as part of one or more delivered BSW modules. It can be put into a framework to let it generate a module's configuration code.		
<b>Kind</b>	Custom		
<b>Relation Type</b>	<b>Related Element</b>	<b>Mul.</b>	<b>Note</b>
Aggregated by	<a href="#">BSW Module Delivered Bundle</a>	0..*	
Produced by	<a href="#">Develop BSW Module Generator</a>	1	
Consumed by	<a href="#">Generate BSW Configuration Code</a>	0..1	This is an input in case a generator framework is used which has to run some module specific generator code.

**Table 3.197: BSW Module Generator**

### 3.5.2.10 AUTOSAR Standardized ECU Configuration Parameter Definition

<b>Artifact</b>	<b>AUTOSAR Standardized ECU Configuration Parameter Definition</b>		
<b>Package</b>	AUTOSAR Root::M2::Methodology::Methodology Library::Bsw::Work products		
<b>Brief Description</b>	Contains all the standardized module definition parameters.		
<b>Description</b>	Contains all the standardized module definition parameters. These parameters must be referred by the vendor specific configuration of a specific module.		
<b>Kind</b>	AUTOSAR XML		
<b>Relation Type</b>	<b>Related Element</b>	<b>Mul.</b>	<b>Note</b>
Aggregated by	<a href="#">BSW Standard Package</a>	1	
Consumed by	<a href="#">Configure Debug</a>	1	
Consumed by	<a href="#">Define Vendor Specific Module Definition</a>	1	
Consumed by	<a href="#">Configure Com</a>	0..1	
Consumed by	<a href="#">Configure Diagnostics</a>	0..1	
Consumed by	<a href="#">Configure ECUC</a>	0..1	
Consumed by	<a href="#">Configure IO Hardware abstraction</a>	0..1	
Consumed by	<a href="#">Configure MCAL</a>	0..1	
Consumed by	<a href="#">Configure Mode Management</a>	0..1	
Consumed by	<a href="#">Configure NvM</a>	0..1	
Consumed by	<a href="#">Configure OS</a>	0..1	
Use meta model element	EcucModuleDef	1	

**Table 3.198: AUTOSAR Standardized ECU Configuration Parameter Definition**

### 3.5.2.11 BSW Module Preconfigured Configuration

<b>Artifact</b>	<b>BSW Module Preconfigured Configuration</b>		
<b>Package</b>	AUTOSAR Root::M2::Methodology::Methodology Library::Bsw::Work products		
<b>Brief Description</b>	Configuration parameter values that are fixed to the object code and cannot be changed without recompilation.		
<b>Description</b>	Configuration parameter values that are pre-configured in the delivered code. They cannot be changed during the ECU integration of the code.  Pre-configuration is possible for object and source code as well.		
<b>Kind</b>	AUTOSAR XML		
<b>Relation Type</b>	<b>Related Element</b>	<b>Mul.</b>	<b>Note</b>
Aggregated by	<a href="#">BSW Module Delivered Bundle</a>	0..*	
Aggregated by	<a href="#">BSW Module ICS Bundle</a>	0..*	The predefined configurations implemented by the modules under test. The modules under test are completely configured.

<i>Relation Type</i>	<i>Related Element</i>	<i>Mul.</i>	<i>Note</i>
Produced by	Configure Compiler Memory Classes	1..*	MemMap config for compiler memclasses: Set the parameter values that define generic MemClassSymbols (i.e. those not defined by modules or SWCs.).  Set the parameter values that define the implementation behind all kind of MemClassSymbols (generic and local ones). Meth.bindingTime = SystemDesignTime
Produced by	Define Memory Addressing Modes	1..*	MemMapAddressingModeSet: Meth.bindingTime = SystemDesignTime
Consumed by	Configure Memmap Allocation	1..*	MemMapAddressingModeSet: Collection of compiler specific configuration elements for memory allocation and addressing modes.
Consumed by	Generate BSW Memory Mapping Header	1..*	MemMapAddressingModeSet: Collection of compiler specific configuration elements for memory allocation. Meth.bindingTime = SystemDesignTime
Consumed by	Generate Compiler Configuration	1..*	CompilerMemClassConfiguration: The parameters "MemMapCompilerMemClassSymbolImpl" and "MemMapGenericCompilerMemClassSymbolImpl" define the implementation behind a MemClassSymbol. Meth.bindingTime = SystemDesignTime
Consumed by	Generate SWC Memory Mapping Header	1..*	MemMapAddressingModeSet: Collection of compiler specific configuration elements for memory allocation. Meth.bindingTime = SystemDesignTime
Use meta model element	EcucModuleConfigurationValues	1	

**Table 3.199: BSW Module Preconfigured Configuration**

### 3.5.2.12 BSW Module Recommended Configuration

<b>Artifact</b>	<b>BSW Module Recommended Configuration</b>		
<b>Package</b>	AUTOSAR Root::M2::Methodology::Methodology Library::Bsw::Work products		
<b>Brief Description</b>	Recommended "default" configuration parameter values.		
<b>Description</b>	Set of configuration parameter values, which are recommended by the module vendor as a default, but are not mandatory for the integration. There can be more than one such set in order to allow for variable usage of the module. This artifact does not include values of so-called published parameters. These must always be given as Basic Software Module Preconfigured Configuration.		
<b>Kind</b>	AUTOSAR XML		
<b>Relation Type</b>	<b>Related Element</b>	<b>Mul.</b>	<b>Note</b>
Aggregated by	<a href="#">BSW Module Delivered Bundle</a>	0..*	
Use meta model element	EcucModuleConfigurationValues	1	

**Table 3.200: BSW Module Recommended Configuration**

### 3.5.2.13 BSW Module Vendor Specific Configuration Parameter Definition

<b>Artifact</b>	<b>BSW Module Vendor- Specific Configuration Parameter Definition</b>		
<b>Package</b>	AUTOSAR Root::M2::Methodology::Methodology Library::Bsw::Work products		
<b>Brief Description</b>	Vendor specific parameter definition for a module. This defines the format of the parameters, not its values.		
<b>Description</b>	Vendor specific parameter definition for a module. This defines the format of the parameters, not its values. In case of a standardized module, it redefines the existing standardized configuration parameter format (ModuleDef).		
<b>Kind</b>	AUTOSAR XML		
<b>Relation Type</b>	<b>Related Element</b>	<b>Mul.</b>	<b>Note</b>
Aggregated by	<a href="#">BSW Module Bundle</a>	0..*	The configuration parameter definitions of the modules under test - needed for static check against the standardized configuration parameters.
Produced by	<a href="#">Define Vendor Specific Module Definition</a>	1	
Consumed by	<a href="#">Configure RTE</a>	1	The definitions for the module RTE
Consumed by	<a href="#">Develop BSW Module Generator</a>	0..*	
Consumed by	<a href="#">Generate BSW Configuration Code</a>	0..*	
Use meta model element	EcucModuleDef	1	

**Table 3.201: BSW Module Vendor- Specific Configuration Parameter Definition**

### 3.5.2.14 BSW Types

<b>Artifact</b>	<b>BSW Types</b>		
<b>Package</b>	AUTOSAR Root::M2::Methodology::Methodology Library::Bsw::Work products		
<b>Brief Description</b>	Set of data types for usage within the Basic Software.		
<b>Description</b>	Set of data types (arxml descriptions) for usage by Basic Software Modules. They will be referred by the Basic Software Module Description		
<b>Kind</b>	AUTOSAR XML		
<b>Relation Type</b>	<b>Related Element</b>	<b>Mul.</b>	<b>Note</b>
Aggregated by	<a href="#">BSW Module Bundle</a>	0..*	
In/out	<a href="#">Define BSW Types</a>	1	
Consumed by	<a href="#">Compile BSW Core Code</a>	1	Meth.bindingTime = CodeGenerationTime
Consumed by	<a href="#">Define BSW Entries</a>	1	
Consumed by	<a href="#">Define BSW Interfaces</a>	1	
Use meta model element	AutosarDataType	1	

**Table 3.202: BSW Types**

### 3.5.2.15 Basic Software Entries

<b>Artifact</b>	<b>Basic Software Entries</b>		
<b>Package</b>	AUTOSAR Root::M2::Methodology::Methodology Library::Bsw::Work products		
<b>Brief Description</b>	Set of signatures for calls between BSW modules.		
<b>Description</b>	Set of signatures for calls between BSW modules. Defining such a set as a separate artifact allows for a better reuse by several BSW modules.They are deccribed in terms of the meta-model element BswModuleEntry which represents a C-function signature and associated properties.		
<b>Kind</b>	AUTOSAR XML		
<b>Relation Type</b>	<b>Related Element</b>	<b>Mul.</b>	<b>Note</b>
Aggregated by	<a href="#">BSW Module Bundle</a>	0..1	
Produced by	<a href="#">Define BSW Entries</a>	1	
Consumed by	<a href="#">Define BSW Interfaces</a>	1	
Use meta model element	BswModuleEntry	1	

**Table 3.203: Basic Software Entries**

### 3.5.2.16 Basic Software Module Description

<b>Artifact</b>	<b>Basic Software Module Description</b>		
<b>Package</b>	AUTOSAR Root::M2::Methodology::Methodology Library::Bsw::Work products		
<b>Brief Description</b>	Description of a single BSW module or a module cluster in terms of its interfaces, dependencies and module Id.		
<b>Description</b>	<p>Description of all interfaces (ingoing and outgoing C-function calls, triggers and modes) and other dependencies of a single BSW module or a module cluster. In addition, this artifacts defines the so-called module Id, which indicates the role of the module within the architecture (only mandatory for standardized modules).</p> <p>Note that the description of the function signatures (so-called BswModuleEntry and their ImplementationDataType can be factored out into separate artifacts BSW Entries and BSW Types in order to improve their reuse.</p>		
<b>Kind</b>	AUTOSAR XML		
<b>Relation Type</b>	<b>Related Element</b>	<b>Mul.</b>	<b>Note</b>
Aggregated by	<a href="#">BSW Module Bundle</a>	1..*	
Produced by	<a href="#">Define BSW Interfaces</a>	1	
Consumed by	<a href="#">Define BSW Behavior</a>	1	
Consumed by	<a href="#">Generate BSW Module Prebuild Data Set</a>	1	Meth.bindingTime = CodeGenerationTime
Consumed by	<a href="#">Generate BSWM Contract Header Files</a>	1	Meth.bindingTime = SystemDesignTime
Consumed by	<a href="#">Implement a BSW Module</a>	1	Meth.bindingTime = SystemDesignTime
Consumed by	<a href="#">Generate BSW Memory Mapping Header</a>	0..1	shortName: The BSW module's shortName is used as the first part of the generated file name, in case the default rule applies. Meth.bindingTime = SystemDesignTime
Use meta model element	BswModuleDescription	1	

**Table 3.204: Basic Software Module Description**

### 3.5.2.17 Basic Software Module Internal Behavior



<b>Artifact</b>	<b>Basic Software Module Internal Behavior</b>		
<b>Package</b>	AUTOSAR Root::M2::Methodology::Methodology Library::Bsw::Work products		
<b>Brief Description</b>	Specifies the InternalBehavior of a BSW module or a BSW cluster, especially the scheduling aspect.		
<b>Description</b>	Specifies the behavior of a BSW module or a BSW cluster w.r.t. the code entities visible by the BSW Scheduler. It is possible to have several different BswInternalBehaviors referring to the same BswModuleDescription, but only one of them can be integrated on one CPU.		
<b>Kind</b>	AUTOSAR XML		
<b>Relation Type</b>	<b>Related Element</b>	<b>Mul.</b>	<b>Note</b>
Aggregated by	<a href="#">BSW Module Delivered Bundle</a>	1..*	
Produced by	<a href="#">Create Library</a>	1	Meth.bindingTime = CodeGenerationTime
Produced by	<a href="#">Define BSW Behavior</a>	1	
Consumed by	<a href="#">Define BSW Module Timing</a>	1	
Consumed by	<a href="#">Generate BSW Module Prebuild Data Set</a>	1	Meth.bindingTime = CodeGenerationTime
Consumed by	<a href="#">Generate BSWM Contract Header Files</a>	1	Meth.bindingTime = SystemDesignTime
Consumed by	<a href="#">Implement a BSW Module</a>	1	Meth.bindingTime = SystemDesignTime
Consumed by	<a href="#">Map Software Component to BSW</a>	1	
Consumed by	<a href="#">Generate Local M C Data Support</a>	0..1	Meth.bindingTime = SystemDesignTime
Use meta model element	BswInternalBehavior	1	

**Table 3.205: Basic Software Module Internal Behavior**

### 3.5.2.18 Basic Software Module Implementation Description

<b>Artifact</b>	<b>Basic Software Module Implementation Description</b>		
<b>Package</b>	AUTOSAR Root::M2::Methodology::Methodology Library::Bsw::Work products		
<b>Brief Description</b>	Contains the implementation specific information of a module.		
<b>Description</b>	Contains the implementation specific information of a module in addition to the generic specification given in Basic Software Module Description and Basic Software Module Internal Behavior.		
<b>Kind</b>	AUTOSAR XML		
<b>Relation Type</b>	<b>Related Element</b>	<b>Mul.</b>	<b>Note</b>

<b>Relation Type</b>	<b>Related Element</b>	<b>Mul.</b>	<b>Note</b>
Aggregated by	BSW Module ICS Bundle	1	The administrative elements (e.g. version info) of the Implementation model needed for the conformance test.
Aggregated by	BSW Module Delivered Bundle	1..*	
Produced by	Create Library	1	Meth.bindingTime = CodeGenerationTime
Produced by	Implement a BSW Module	1	Meth.bindingTime = CodeGenerationTime
Consumed by	Generate BSW Memory Mapping Header	1	infixes: Optional infixes (denoting instance and vendor ID) to be used within the created header file name. Meth.bindingTime = SystemDesignTime
Consumed by	Generate BSW Memory Mapping Header	1	DependencyOnArtifact: Can be used to override the default name of the memory mapping header file. Meth.bindingTime = SystemDesignTime
Consumed by	Generate BSW Memory Mapping Header	1	MemorySections: MemorySections defined for a BSW module. This input includes optional prefixes for memory sections overriding the default rule. Meth.bindingTime = SystemDesignTime
Consumed by	Generate BSW Module Prebuild Data Set	1	Meth.bindingTime = CodeGenerationTime
Consumed by	Generate BSWM Contract Header Files	1	Meth.bindingTime = SystemDesignTime
Consumed by	Generate Compiler Configuration	1..*	MemorySections: Find referred SwAddrMethods or specific memClassSymbols in the MemorySections defined for BSW modules. Meth.bindingTime = SystemDesignTime
Consumed by	Configure Memmap Allocation	0..*	MemorySections:
Use meta model element	BswImplementation	1	

**Table 3.206: Basic Software Module Implementation Description**

### 3.5.2.19 Build Action Manifest

<b>Artifact</b>	<b>Build Action Manifest</b>		
<b>Package</b>	AUTOSAR Root::M2::Methodology::Methodology Library::Bsw::Work products		
<b>Brief Description</b>	Describes the actions used to build certain artifacts from other artifacts.		
<b>Description</b>	<p>Describes the actions used to build certain artifacts from other artifacts (generate, compile, link...).</p> <p>Note: A build action manifest can include the actions for processing of basic software as well as of application software artifacts. The manifest itself is however considered as a product of basic software development.</p>		
<b>Kind</b>	AUTOSAR XML		
<b>Relation Type</b>	<b>Related Element</b>	<b>Mul.</b>	<b>Note</b>
Aggregated by	<a href="#">BSW Module Delivered Bundle</a>	0..1	The build action manifest to be used for the delivered basic software.
Produced by	<a href="#">Implement a BSW Module</a>	0..1	
Consumed by	<a href="#">Compile BSW Core Code</a>	0..1	The compilation can optionally be controlled by a Build Action Manifest.
Consumed by	<a href="#">Compile ECU Source Code</a>	0..1	The task may be controlled by a Build Action Manifest.
Consumed by	<a href="#">Connect Service Component</a>	0..1	The task may be controlled by a Build Action Manifest.
Consumed by	<a href="#">Generate A2L</a>	0..1	The task may be controlled by a Build Action Manifest.
Consumed by	<a href="#">Generate BSW Configuration Code</a>	0..1	The task may be controlled by a Build Action Manifest.
Consumed by	<a href="#">Generate ECU Executable</a>	0..1	The task may be controlled by a Build Action Manifest.
Consumed by	<a href="#">Generate OS</a>	0..1	The task may be controlled by a Build Action Manifest.
Consumed by	<a href="#">Generate RTE Postbuild Dataset</a>	0..1	The task may be controlled by a Build Action Manifest.
Consumed by	<a href="#">Generate RTE Prebuild Dataset</a>	0..1	The task may be controlled by a Build Action Manifest.
Use meta model element	BuildActionManifest	1	

**Table 3.207: Build Action Manifest**

### 3.5.2.20 Basic Software Module Timing

<b>Artifact</b>	<b>Basic Software Module Timing</b>		
<b>Package</b>	AUTOSAR Root::M2::Methodology::Methodology Library::Bsw::Work products		
<b>Brief Description</b>	BSW module's TimingDescription and TimingConstraints		
<b>Description</b>	TimingDescription and TimingConstraints defined for the Internal Behavior of a BSW module (BSWModuleEntities)		
<b>Kind</b>	AUTOSAR XML		
<b>Relation Type</b>	<b>Related Element</b>	<b>Mul.</b>	<b>Note</b>
Aggregated by	<a href="#">BSW Module Bundle</a>	0..1	
Produced by	<a href="#">Define BSW Module Timing</a>	1	
Consumed by	<a href="#">Define ECU Timing</a>	0..1	
Consumed by	<a href="#">Implement a BSW Module</a>	0..1	Meth.bindingTime = SystemDesignTime
Use meta model element	BswModuleTiming	1	

**Table 3.208: Basic Software Module Timing**

### 3.5.2.21 Basic Software Module Core Header

<b>Artifact</b>	<b>Basic Software Module Core Header</b>		
<b>Package</b>	AUTOSAR Root::M2::Methodology::Methodology Library::Bsw::Work products		
<b>Brief Description</b>	C-header files delivered with a BSW module.		
<b>Description</b>	C-header file delivered with a BSW module. It may have to be included by other modules.		
<b>Kind</b>	Source Code		
<b>Relation Type</b>	<b>Related Element</b>	<b>Mul.</b>	<b>Note</b>
Aggregated by	<a href="#">BSW Module Delivered Bundle</a>	1..*	
Produced by	<a href="#">Implement a BSW Module</a>	1	Meth.bindingTime = CodeGenerationTime
Consumed by	<a href="#">Compile BSW Configuration Data</a>	1	
Consumed by	<a href="#">Compile BSW Core Code</a>	1	Meth.bindingTime = CodeGenerationTime
Consumed by	<a href="#">Compile Configured BSW</a>	1	
Consumed by	<a href="#">Compile Unconfigured BSW</a>	1	
Consumed by	<a href="#">Compile ECU Source Code</a>	0..*	Meth.bindingTime = CodeGenerationTime

**Table 3.209: Basic Software Module Core Header**

### 3.5.2.22 Basic Software Module Core Source Code

<b>Artifact</b>	<b>Basic Software Module Core Source Code</b>		
<b>Package</b>	AUTOSAR Root::M2::Methodology::Methodology Library::Bsw::Work products		
<b>Brief Description</b>	The core source code of a module provided by the vendor.		
<b>Description</b>	The core source code of a module provided by the vendor. "Core" means, that it does not include additional source code, which may be generated during the configuration process.		
<b>Kind</b>	Source Code		
<b>Relation Type</b>	<b>Related Element</b>	<b>Mul.</b>	<b>Note</b>
Aggregated by	<a href="#">BSW Module Delivered Bundle</a>	0..*	
Produced by	<a href="#">Implement a BSW Module</a>	0..1	The creation of source code is optional, since it might be generated completely in a later step based on the Build Action Manifest. Meth.bindingTime = CodeGenerationTime
Consumed by	<a href="#">Compile BSW Core Code</a>	1	Meth.bindingTime = CodeGenerationTime
Consumed by	<a href="#">Compile Configured BSW</a>	1	
Consumed by	<a href="#">Compile Unconfigured BSW</a>	1	
Consumed by	<a href="#">Compile ECU Source Code</a>	0..*	Meth.bindingTime = CodeGenerationTime

**Table 3.210: Basic Software Module Core Source Code**

### 3.5.2.23 Basic Software Interlink Header

<b>Artifact</b>	<b>Basic Software Module Interlink Header</b>		
<b>Package</b>	AUTOSAR Root::M2::Methodology::Methodology Library::Bsw::Work products		
<b>Brief Description</b>	Generated Header file used to link a BSW module with the BSW Scheduler.		
<b>Description</b>	Generated Header file used to link a BSW module with the BSW Scheduler during Contract phase.		
<b>Kind</b>	Source Code		
<b>Relation Type</b>	<b>Related Element</b>	<b>Mul.</b>	<b>Note</b>
Aggregated by	<a href="#">BSW Module Delivered Bundle</a>	1..*	
Produced by	<a href="#">Generate BSWM Contract Header Files</a>	1	Meth.bindingTime = CodeGenerationTime
Consumed by	<a href="#">Compile BSW Core Code</a>	1	Meth.bindingTime = CodeGenerationTime
Consumed by	<a href="#">Implement a BSW Module</a>	1	Meth.bindingTime = SystemDesignTime
Consumed by	<a href="#">Compile ECU Source Code</a>	1..*	Meth.bindingTime = CodeGenerationTime

<i>Relation Type</i>	<i>Related Element</i>	<i>Mul.</i>	<i>Note</i>
----------------------	------------------------	-------------	-------------

**Table 3.211: Basic Software Module Interlink Header**

### 3.5.2.24 Basic Software Interlink Types Header

<i>Artifact</i>	<b>Basic Software Interlink Types Header</b>		
<b>Package</b>	AUTOSAR Root::M2::Methodology::Methodology Library::Bsw::Work products		
<b>Brief Description</b>	Generated Header file with data types used to link a BSW module with the BSW Scheduler		
<b>Description</b>	Generated Header file with data types used to link a BSW module with the BSW Scheduler.		
<b>Kind</b>	Source Code		
<i>Relation Type</i>	<i>Related Element</i>	<i>Mul.</i>	<i>Note</i>
Aggregated by	<a href="#">BSW Module Delivered Bundle</a>	0..*	
Produced by	<a href="#">Generate BSW Contract Header Files</a>	1	Meth.bindingTime = CodeGenerationTime
Consumed by	<a href="#">Compile BSW Core Code</a>	1	Meth.bindingTime = CodeGenerationTime
Consumed by	<a href="#">Implement a BSW Module</a>	1	Meth.bindingTime = SystemDesignTime
Consumed by	<a href="#">Compile ECU Source Code</a>	0..*	Meth.bindingTime = CodeGenerationTime

**Table 3.212: Basic Software Interlink Types Header**

### 3.5.2.25 BSW RTE Prebuild Configuration Header

<i>Artifact</i>	<b>BSW RTE Prebuild Configuration Header</b>		
<b>Package</b>	AUTOSAR Root::M2::Methodology::Methodology Library::Bsw::Work products		
<b>Brief Description</b>	Generated header file used to resolve the prebuild variants in the prebuild RTE contract phase for the BSW.		
<b>Description</b>	Generated header file used to resolve the prebuild variants of a basic software module in the prebuild RTE contract phase. Contains macros which resolve the variants when compiled with the module.		
<b>Kind</b>	Bound Source Code		
<i>Relation Type</i>	<i>Related Element</i>	<i>Mul.</i>	<i>Note</i>
Aggregated by	<a href="#">BSW Module Delivered Bundle</a>	0..*	
Produced by	<a href="#">Generate BSW Module Prebuild Data Set</a>	1	Meth.bindingTime = PreCompileTime
Consumed by	<a href="#">Compile BSW Core Code</a>	1	Meth.bindingTime = PreCompileTime

<i>Relation Type</i>	<i>Related Element</i>	<i>Mul.</i>	<i>Note</i>
Consumed by	Compile ECU Source Code	0..*	Meth.bindingTime = PreCompileTime

**Table 3.213: BSW RTE Prebuild Configuration Header**

### 3.5.2.26 Basic Software Module Object Code

<i>Artifact</i>	<b>Basic Software Module Object Code</b>		
<i>Package</i>	AUTOSAR Root::M2::Methodology::Methodology Library::Bsw::Work products		
<i>Brief Description</i>	Object code of a BSW module.		
<i>Description</i>	Object code of a BSW module.		
<i>Kind</i>	Object Code		
<i>Relation Type</i>	<i>Related Element</i>	<i>Mul.</i>	<i>Note</i>
Aggregated by	BSW Module ICS Bundle	1..*	
Aggregated by	BSW Module De-livered Bundle	0..*	
Produced by	Compile BSW Core Code	1	Meth.bindingTime = CompileTime
Produced by	Compile Config-ured BSW	1	
Produced by	Compile Gener-ated BSW	1	
Produced by	Compile Unconfig-ured BSW	1	
Consumed by	Link ECU Code after Precompile Configuration	1..*	
Consumed by	Link ECU Code during Link Time Configuration	1..*	
Consumed by	Link ECU Code during Post-build Time Selectable	1..*	
Consumed by	Generate ECU Ex-ecutable	0..*	for object code delivery Meth.bindingTime = CompileTime

**Table 3.214: Basic Software Module Object Code**

### 3.5.2.27 Library Description

<b>Artifact</b>	<b>Library Description</b>		
<b>Package</b>	AUTOSAR Root::M2::Methodology::Methodology Library::Bsw::Work products		
<b>Brief Description</b>	Description of a library in Autosar XML.		
<b>Description</b>	Description of a library in Autosar XML. This uses the same template as for describing Basic Software Modules, but with restricted content. Main purpose is to describe the C-interfaces of the library.		
<b>Kind</b>	AUTOSAR XML		
<b>Relation Type</b>	<b>Related Element</b>	<b>Mul.</b>	<b>Note</b>
Produced by	<a href="#">Create Library</a>	1	Meth.bindingTime = CodeGenerationTime
Consumed by	<a href="#">Implement Atomic Software Component</a>	0..*	Meth.bindingTime = CodeGenerationTime
Use meta model element	BswModuleDescription	1	

**Table 3.215: Library Description**

### 3.5.2.28 Library Header Files

<b>Artifact</b>	<b>Library Header Files</b>		
<b>Package</b>	AUTOSAR Root::M2::Methodology::Methodology Library::Bsw::Work products		
<b>Brief Description</b>	These additional headers are typically needed for libraries that a component uses.		
<b>Description</b>	These additional headers are typically needed for libraries that a component or a module uses (e.g. a "math-library").		
<b>Kind</b>	Source Code		
<b>Relation Type</b>	<b>Related Element</b>	<b>Mul.</b>	<b>Note</b>
Produced by	<a href="#">Create Library</a>	1	Meth.bindingTime = CodeGenerationTime
Consumed by	<a href="#">Compile BSW Core Code</a>	0..1	Meth.bindingTime = CodeGenerationTime
Consumed by	<a href="#">Implement a BSW Module</a>	0..1	Meth.bindingTime = CodeGenerationTime
Consumed by	<a href="#">Compile Atomic Software Component</a>	0..*	Meth.bindingTime = CodeGenerationTime
Consumed by	<a href="#">Compile ECU Source Code</a>	0..*	Meth.bindingTime = CodeGenerationTime
Consumed by	<a href="#">Implement Atomic Software Component</a>	0..*	Meth.bindingTime = CodeGenerationTime
Consumed by	<a href="#">Re-compile Component in ECU context</a>	0..*	Meth.bindingTime = CodeGenerationTime

**Table 3.216: Library Header Files**



### 3.5.2.29 Library Object Code

<b>Artifact</b>	<b>Library Object Code</b>		
<b>Package</b>	AUTOSAR Root::M2::Methodology::Methodology Library::Bsw::Work products		
<b>Brief Description</b>	The object code of a library.		
<b>Description</b>	The object code of a library, to be linked with other object code during a build of the ECU executable.		
<b>Kind</b>	Object Code		
<b>Relation Type</b>	<b>Related Element</b>	<b>Mul.</b>	<b>Note</b>
Aggregated by	Delivered Atomic Software Components	0..*	
Produced by	Create Library	1	Meth.bindingTime = CodeGenerationTime
Consumed by	Generate ECU Executable	0..*	for object code delivery Meth.bindingTime = CompileTime

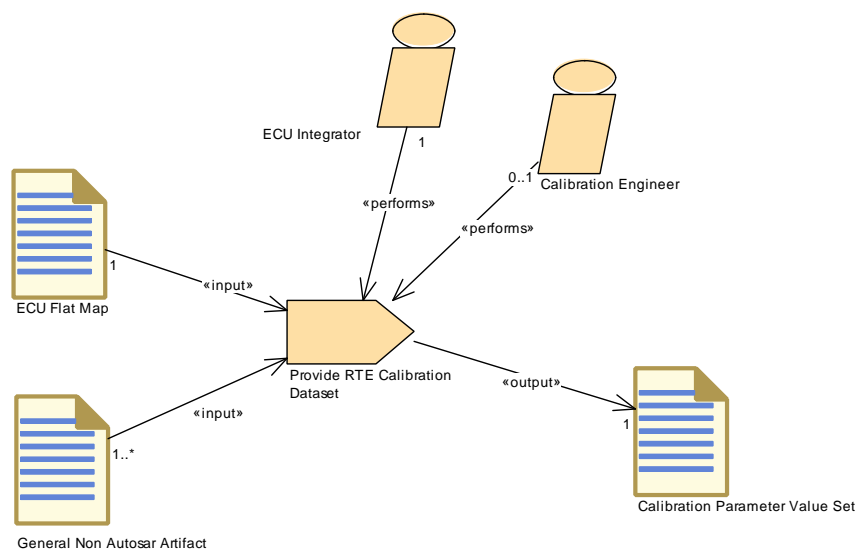
**Table 3.217: Library Object Code**

## 3.6 ECU Integration and Configuration

This chapter contains the definition of work products and tasks used for the integration and configuration of AUTOSAR software on an ECU. For the definition of the relevant meta-model elements refer to [7].

### 3.6.1 Tasks

#### 3.6.1.1 Provide RTE Calibration Dataset

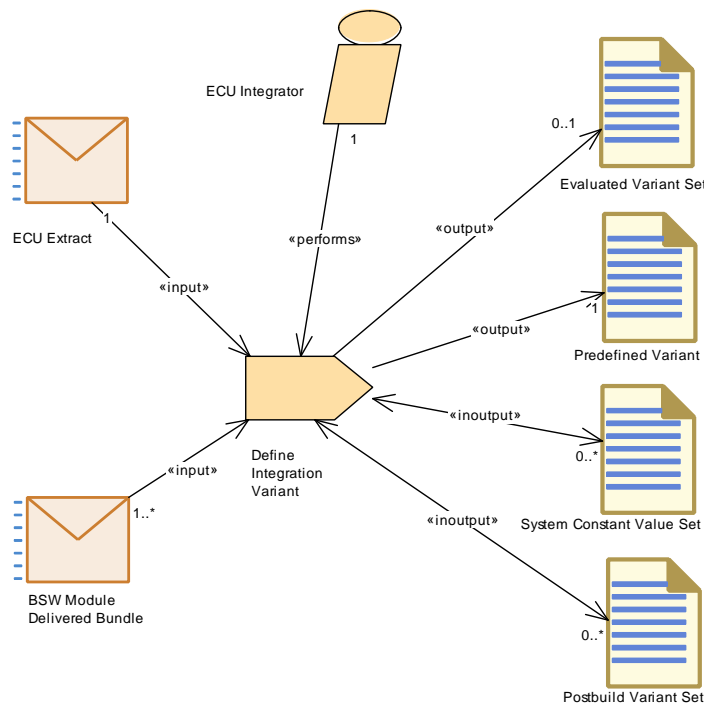


**Figure 3.101: Provide RTE Calibration Dataset**

<b>Task Definition</b>	<b>Provide RTE Calibration Dataset</b>		
<b>Package</b>	AUTOSAR Root::M2::Methodology::Methodology Library::Ecu::Tasks		
<b>Brief Description</b>	Provide a data set defining initial values for calibration parameters in the RTE code.		
<b>Description</b>	<p>Since a model of the "downstream" calibration process of an ECU is not part of the AUTOSAR methodology, the input data are only shown as a General Non AUTOSAR Artifact.</p> <p>The output of this task is a set of calibration values in AUTOSAR format, which can be further processed within AUTOSAR, namely by the RTE generator. The calibration values have to be associated to the corresponding parameter specification via a reference to the ECU Flat Map.</p>		
<b>Relation Type</b>	<b>Related Element</b>	<b>Mul.</b>	<b>Note</b>
Performed by	ECU Integrator	1	
Performed by	Calibration Engineer	0..1	
Consumes	ECU Flat Map	1	
Consumes	General Non Autosar Artifact	1..*	input from calibration process
Produces	Calibration Parameter Value Set	1	

**Table 3.218: Provide RTE Calibration Dataset**

### 3.6.1.2 Define Integration Variant

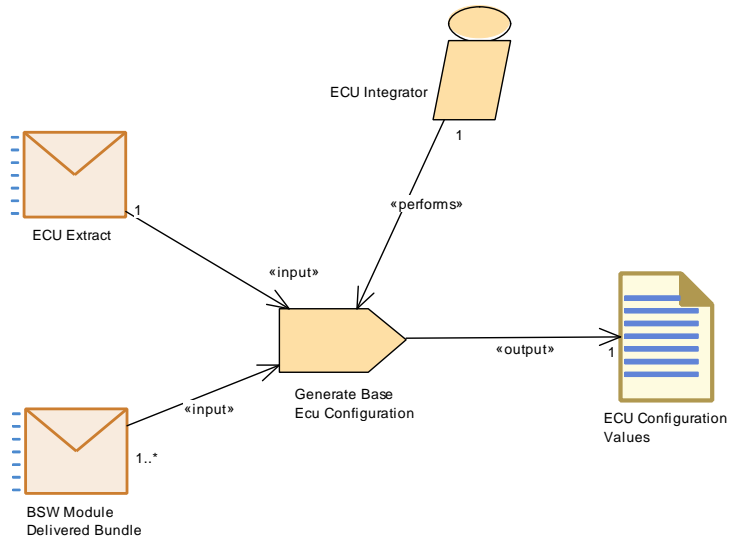


**Figure 3.102: Define Integration Variant**

<b>Task Definition</b>	<b>Define Integration Variant</b>		
<b>Package</b>	AUTOSAR Root::M2::Methodology::Methodology Library::Ecu::Tasks		
<b>Brief Description</b>	Define a variant for the artifacts integrated on an ECU.		
<b>Description</b>	<p>Define a variant for the artifacts integrated on an ECU, this means adding a PredefinedVariant related to the ECU extract and the BSW modules in scope. To do so, this task can make use of existing System Constant Value Set and/or Postbuild Variant Sets or define new ones.</p> <p>Several PredefinedVariants can be combined to one Evaluated Variant Set.</p> <p>It is up to particular process definition to decide, which variants are allowed to be set at integration time. Technically, since this task is part of ECU integration, it can only resolve variation points which have not yet been resolved in the delivered ECU extract or BSW modules. Especially, variation points which have to be bound at system design time, should have been already resolved before.</p> <p>Meth.bindingTime = SystemDesignTime</p>		
<b>Relation Type</b>	<b>Related Element</b>	<b>Mul.</b>	<b>Note</b>
Performed by	<a href="#">ECU Integrator</a>	1	
Consumes	<a href="#">ECU Extract</a>	1	
Consumes	<a href="#">BSW Module Delivered Bundle</a>	1..*	
In/out	<a href="#">Postbuild Variant Set</a>	0..*	
In/out	<a href="#">System Constant Value Set</a>	0..*	
Produces	<a href="#">Predefined Variant</a>	1	Meth.bindingTime = SystemDesignTime
Produces	<a href="#">Evaluated Variant Set</a>	0..1	Meth.bindingTime = SystemDesignTime

**Table 3.219: Define Integration Variant**

### 3.6.1.3 Generate Base ECU Configuration

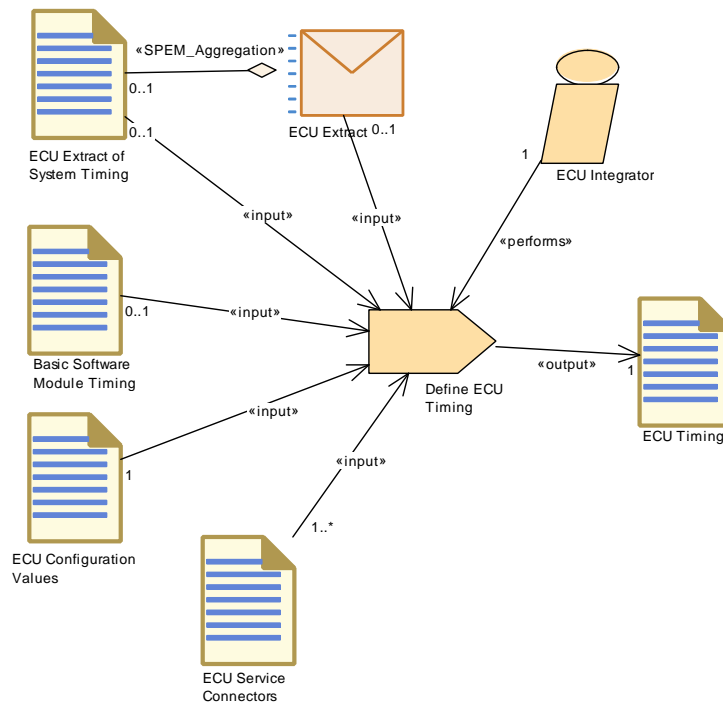


**Figure 3.103: Generate Base ECU Configuration**

<b>Task Definition</b>	<b>Generate Base Ecu Configuration</b>		
<b>Package</b>	AUTOSAR Root::M2::Methodology::Methodology Library::Ecu::Tasks		
<b>Brief Description</b>	Generate an initial set of ECU configuration values based on the delivered ECU extract.		
<b>Description</b>	<p>Create the ECU configuration module structure including an initial set of ECU configuration values.</p> <p>This is based on the delivered ECU extract and on the vendor specific configuration parameters and their recommended or pre-configured values provided with the delivered BSW modules.</p> <p>Meth.bindingTime = SystemDesignTime</p>		
<b>Relation Type</b>	<b>Related Element</b>	<b>Mul.</b>	<b>Note</b>
Performed by	<a href="#">ECU Integrator</a>	1	
Consumes	<a href="#">ECU Extract</a>	1	
Consumes	<a href="#">BSW Module Delivered Bundle</a>	1..*	Need vendor specific configuration parameters and their recommended or pre-configured values.
Produces	<a href="#">ECU Configuration Values</a>	1	Meth.bindingTime = SystemDesignTime

**Table 3.220: Generate Base Ecu Configuration**

### 3.6.1.4 Define ECU Timing

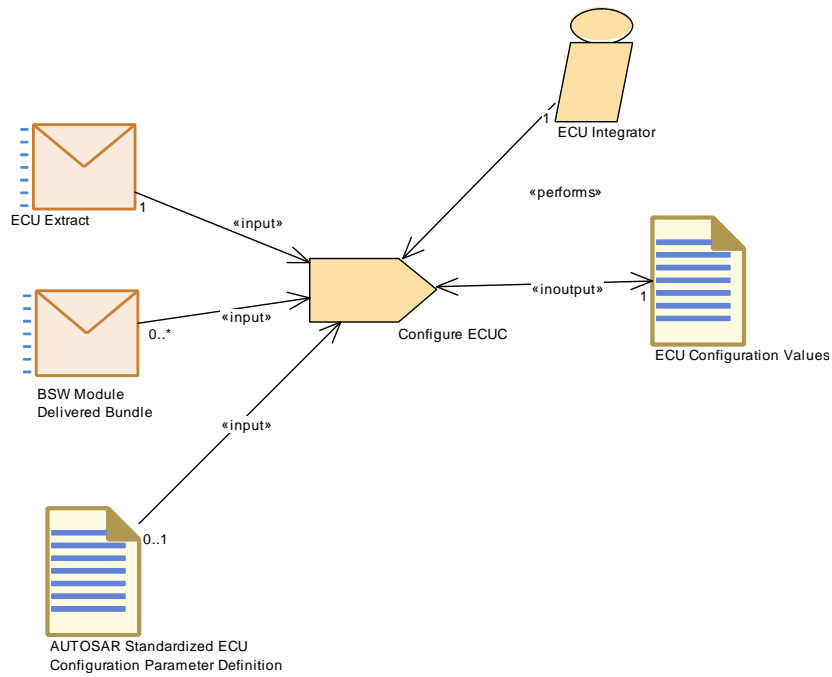


**Figure 3.104: Define ECU Timing**

<b>Task Definition</b>	<b>Define ECU Timing</b>		
<b>Package</b>	AUTOSAR Root::M2::Methodology::Methodology Library::Ecu::Tasks		
<b>Brief Description</b>	Define ECUTiming (TimingDescription and TimingConstraints) for a concrete ECU taking the ECU configuration and the ECU Software Composition (including their implementation) into account.		
<b>Description</b>	Define ECUTiming (TimingDescription and TimingConstraints) for a concrete ECU taking the ECU configuration and the ECU Software Composition (including their implementation) into account.  Meth.bindingTime = SystemDesignTime		
<b>Relation Type</b>	<b>Related Element</b>	<b>Mul.</b>	<b>Note</b>
Performed by	<a href="#">ECU Integrator</a>	1	
Consumes	<a href="#">ECU Configuration Values</a>	1	
Consumes	<a href="#">ECU Service Connectors</a>	1..*	
Consumes	<a href="#">Basic Software Module Timing</a>	0..1	
Consumes	<a href="#">ECU Extract</a>	0..1	Needed to set up links to the elements of the ECU extract.
Consumes	<a href="#">ECU Extract of System Timing</a>	0..1	
Produces	<a href="#">ECU Timing</a>	1	Meth.bindingTime = SystemDesignTime

**Table 3.221: Define ECU Timing**

### 3.6.1.5 Configure EcuC

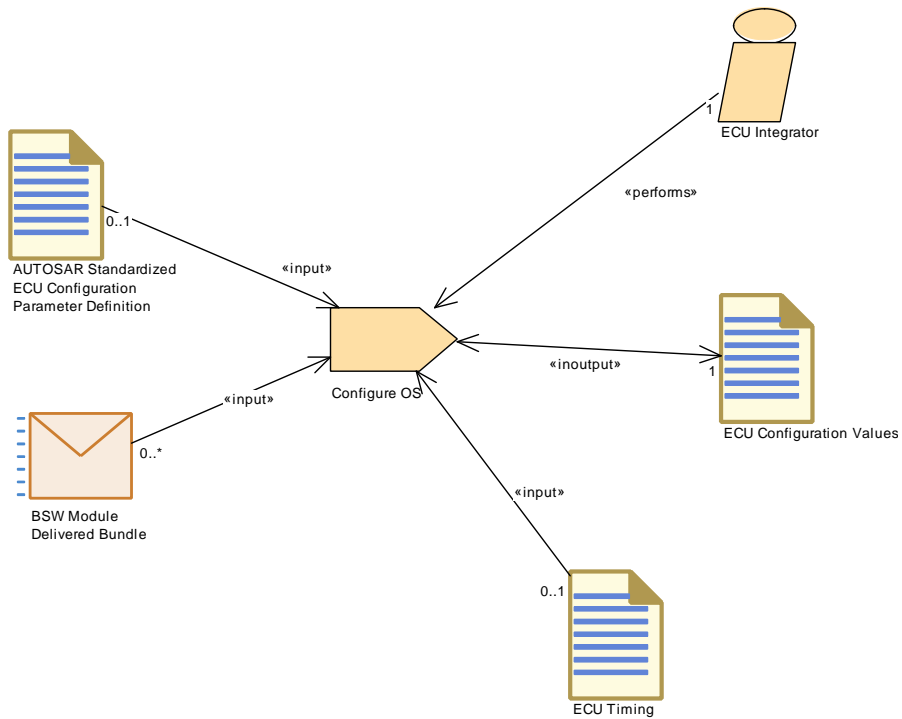


**Figure 3.105: Configure EcuC**

<b>Task Definition</b>	<b>Configure ECUC</b>		
<b>Package</b>	AUTOSAR Root::M2::Methodology::Methodology Library::Ecu::Tasks		
<b>Brief Description</b>	Set the general ECU configuration values.		
<b>Description</b>	<p>Set the general ECU configuration values, the so-called EcuC parameters. These are the configuration parameters which are not related to a particular module, but are relevant for the ECU in general. The EcuC parameters consist of the following parts:</p> <ul style="list-style-type: none"> <li>• Collection of all Pdu objects flowing through the Com-Stack.</li> <li>• Definition of partitions for the ECU (One partition will be implemented using one OS application). The memory partitions have to be known before doing the OS configuration.</li> <li>• Collection of PredefinedVariant elements which shall be applied when resolving the variability during ECU Configuration.</li> <li>• Collection of mappings between ECU hardware memory segments (defined in ECU Resources Description) and SwAddrMethod elements (defined in VFB Types). The name of each such EcucMemoryMappingElement could be used as to predefine the logical memory segment for the linker configuration.</li> </ul> <p>Note: The usage of EcucMemoryMappingElement is deprecated in R4.0 rev.2, because the configuration of the "MemMap" module has been added which allows a more fined grained memory mapping than SwAddrmethod. A relationship to hardware elements from this fine grained mapping is currently not provided. See task definition Configure Memmap Allocation.</p> <p>Meth.bindingTime = SystemDesignTime</p>		
<b>Relation Type</b>	<b>Related Element</b>	<b>Mul.</b>	<b>Note</b>
Performed by	<a href="#">ECU Integrator</a>	1	
Consumes	<a href="#">ECU Extract</a>	1	
Consumes	<a href="#">AUTOSAR Standardized ECU Configuration Parameter Definition</a>	0..1	
Consumes	<a href="#">BSW Module Delivered Bundle</a>	0..*	
In/out	<a href="#">ECU Configuration Values</a>	1	

**Table 3.222: Configure ECUC**

**3.6.1.6 Configure OS**



**Figure 3.106: Configure OS**

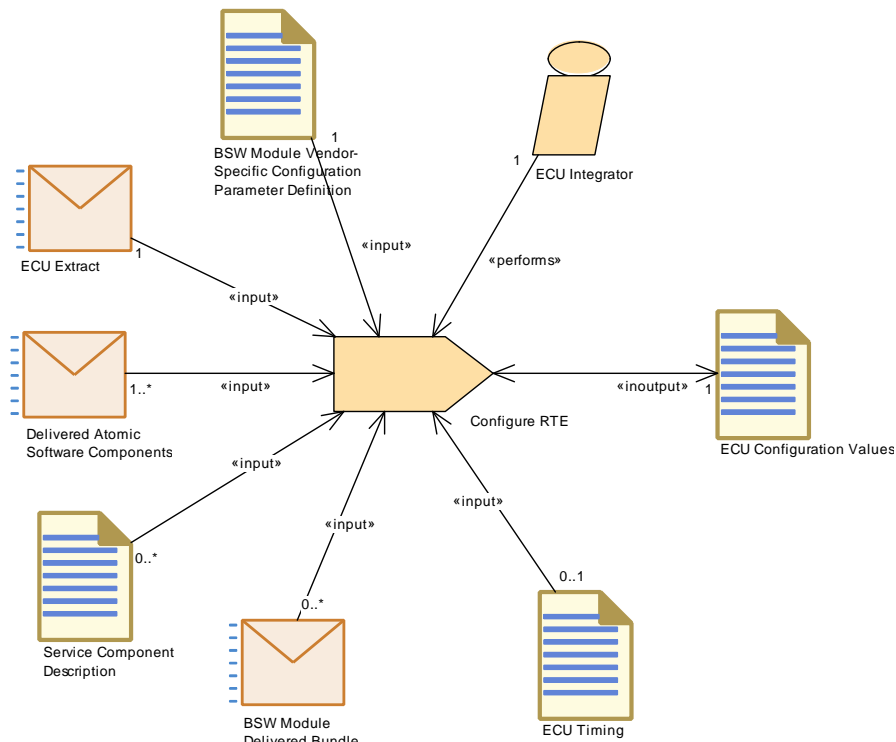


<b>Task Definition</b>	<b>Configure OS</b>		
<b>Package</b>	AUTOSAR Root::M2::Methodology::Methodology Library::Ecu::Tasks		
<b>Brief Description</b>	Configure the OS by creating the Tasks, events, alarms, etc.		
<b>Description</b>	<p>The OS configuration process may be highly iterative between RTE and OS, e.g. RTE needs some OsTasks or OsScheduleTables to map Runnables into them. To finalize a ECU Configuration the OS is the last BSW module to configure (with the exception of the debugger). To use multi-core ECUs the EcuC Configuration needs to be provided beforehand to the OS Configuration to map the cores. There cannot be specified a precedence which configuration parameter values should be set first for OsAlarm, OsApplication, OsCounter, Oslsr, OsOs, OsResource, OsScheduleTable, OsSpinlock, OsTask. This is dependent on the development and configuration process. Application + Basic Software requirements and fulfill those with OS artifacts.</p> <p>Mandatory Inputs:</p> <ul style="list-style-type: none"> <li>• RTE part of the ECU Configuration</li> <li>• EcuC part of the ECU Configuration</li> </ul> <p>Outputs:</p> <ul style="list-style-type: none"> <li>• OS part of the ECU Configuration</li> <li>• RTE part of the ECU Configuration</li> </ul> <p>The following steps are needed to perform the task :</p> <ul style="list-style-type: none"> <li>• Map OS Configuration to Cores only in the case of multiple core ECU.</li> <li>• Define the OSTasks and OSSchedule : Tables based on the events/runnables of the application &amp; bsw components, create the OSTasks that will invoke them.</li> <li>• Map Runnables into OSTasks and OSSchedule Tables : Assign all the runnables to the OSTasks</li> <li>• Steps for "OsAlarm, OsApplication, OsCounter, Oslsr, OsOs, OsResource, OsScheduleTable, OsSpinlock, OsTask."</li> </ul> <p>Meth.bindingTime = SystemDesignTime</p>		
<b>Relation Type</b>	<b>Related Element</b>	<b>Mul.</b>	<b>Note</b>
Performed by	<a href="#">ECU Integrator</a>	1	
Consumes	<a href="#">AUTOSAR Standardized ECU Configuration Parameter Definition</a>	0..1	
Consumes	<a href="#">ECU Timing</a>	0..1	

Relation Type	Related Element	Mul.	Note
Consumes	BSW Module Delivered Bundle	0..*	OS Resources required by Basic Software.  Optional Input: Basic Software Module Timing, e.g. execution order constraints.
In/out	ECU Configuration Values	1	

**Table 3.223: Configure OS**

### 3.6.1.7 Configure RTE



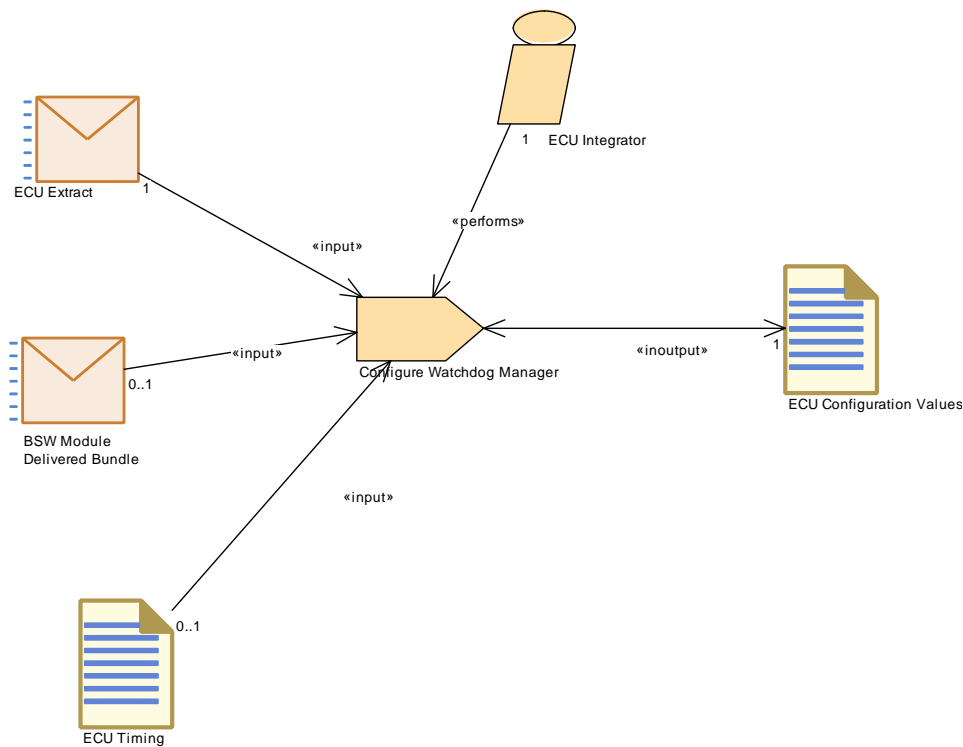
**Figure 3.107: Configure RTE**

<b>Task Definition</b>	<b>Configure RTE</b>		
<b>Package</b>	AUTOSAR Root::M2::Methodology::Methodology Library::Ecu::Tasks		
<b>Brief Description</b>	Describes the steps required to successfully configure the AUTOSAR RTE.		
<b>Description</b>	<p>Configure the RTE to correctly interact with AUTOSAR COM and the OS. The specification of the OS objects used by the generated RTE are configured in this task. In addition, configuration includes setting RTE specific options and the handling of measurement and calibration data. Post-build variants which shall be supported by the RTE code must be referenced by the configuration.</p> <p>The following steps are usually done to configure the RTE : 1.Setup RTE General Configuration 2.Select Software Component Implementations 3.Select BSW Module Implementations 4.Each Runnable needs to be assigned to an Operating System Task in order to be invoked. 5.Map BSW Executables to tasks 6.Resolve Exclusive Areas 7.Select Implicit Communication behavior 8.Select Calibration Support 9.Configure Non Volatile Memory Block Component (only needed if decisions on the configuration have to be taken during ECU Configuration) 10.Select the supported post-build variants</p> <p>Meth.bindingTime = SystemDesignTime</p>		
<b>Relation Type</b>	<b>Related Element</b>	<b>Mul.</b>	<b>Note</b>
Performed by	<a href="#">ECU Integrator</a>	1	
Consumes	<a href="#">BSW Module Vendor-Specific Configuration Parameter Definition</a>	1	The definitions for the module RTE
Consumes	<a href="#">ECU Extract</a>	1	<p>Elements of the System Description and VFB Description are referred by the RTE configuration.</p> <p>Optional Input: ECU Extract of System Timing, e.g. execution order constraints.</p>
Consumes	<a href="#">Delivered Atomic Software Components</a>	1..*	<p>Required input:</p> <ul style="list-style-type: none"> <li>References to all component implementation descriptions on this ECU</li> <li>SwcInternalBehavior (for example to map the runnables to tasks) which was used in the contract phase of the software components on this ECU</li> </ul>
Consumes	<a href="#">ECU Timing</a>	0..1	
Consumes	<a href="#">BSW Module Delivered Bundle</a>	0..*	<p>Input from the BSW Module Description is needed related to Scheduling, Exclusive Areas, Triggers and Modes.</p> <p>Optional Input: Basic Software Module Timing, e.g. execution order constraints.</p>

Relation Type	Related Element	Mul.	Note
Consumes	Service Component Description	0..*	The Internal Behavior of Service Components contributes to the RTE configuration.
In/out	ECU Configuration Values	1	

**Table 3.224: Configure RTE**

### 3.6.1.8 Configure Watchdog Manager



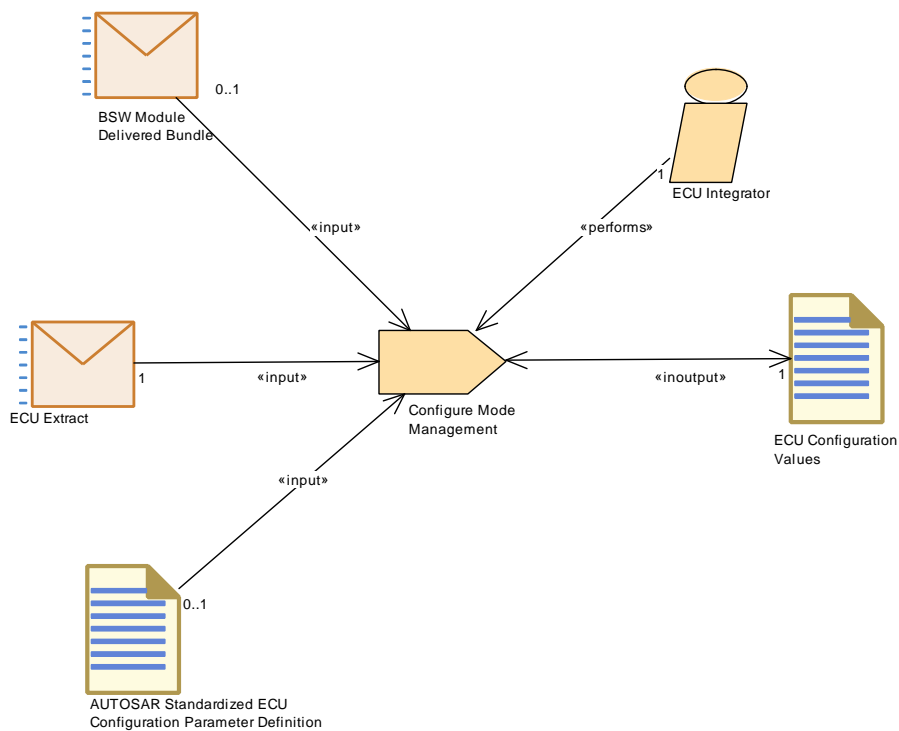
**Figure 3.108: Configure Watchdog Manager**

<b>Task Definition</b>	<b>Configure Watchdog Manager</b>		
<b>Package</b>	AUTOSAR Root::M2::Methodology::Methodology Library::Ecu::Tasks		
<b>Brief Description</b>	Describes the steps required to successfully configure the Watchdog Manager		
<b>Description</b>	Configured Top-Down. Service needs determine what kind of watchdog manager you need. For each service need there is one interface. You can connect several of these interfaces to one watchdog manager  Meth.bindingTime = SystemDesignTime		
<b>Relation Type</b>	<b>Related Element</b>	<b>Mul.</b>	<b>Note</b>
Performed by	ECU Integrator	1	

Relation Type	Related Element	Mul.	Note
Consumes	<a href="#">ECU Extract</a>	1	Application software requirements for WdgM, especially SwcServiceDependency and ServiceNeeds.
Consumes	<a href="#">BSW Module Delivered Bundle</a>	0..1	Predefined or recommended configuration values, vendor specific parameters, ServiceNeeds defined by BSW.
Consumes	<a href="#">ECU Timing</a>	0..1	
In/out	<a href="#">ECU Configuration Values</a>	1	

**Table 3.225: Configure Watchdog Manager**

### 3.6.1.9 Configure Mode Management

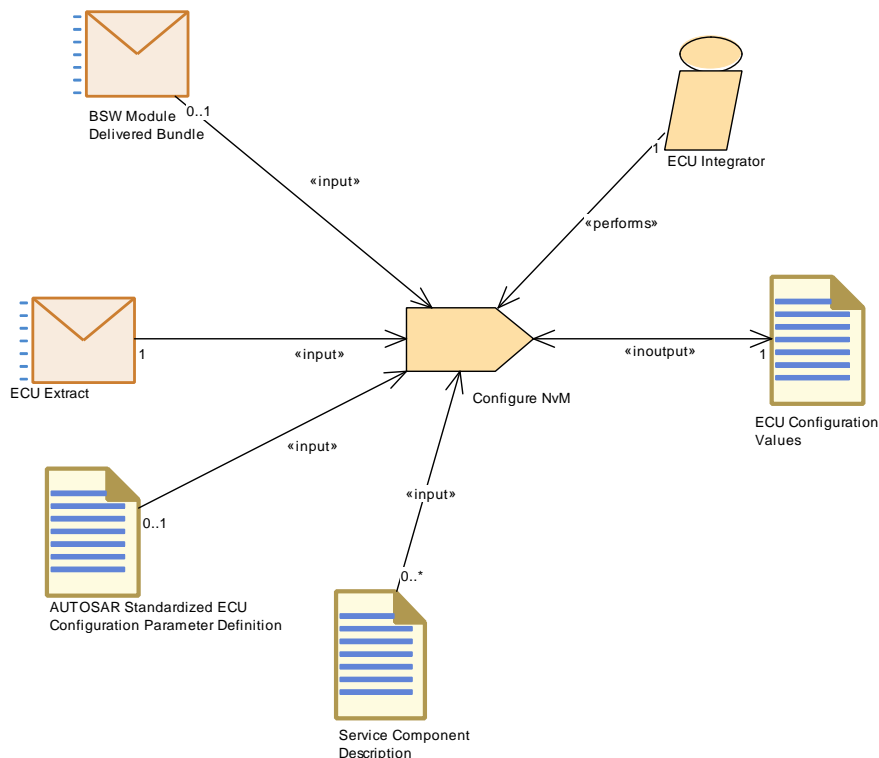


**Figure 3.109: Configure Mode Management**

<b>Task Definition</b>	<b>Configure Mode Management</b>		
<b>Package</b>	AUTOSAR Root::M2::Methodology::Methodology Library::Ecu::Tasks		
<b>Brief Description</b>	Configure the Mode Managers in the Basic Software for this ECU.		
<b>Description</b>	Configure the Mode Managers in the Basic Software for this ECU. In the methodology library this is modeled as a single task (for simplicity) though in practice it may consist of several single tasks.  Meth.bindingTime = SystemDesignTime		
<b>Relation Type</b>	<b>Related Element</b>	<b>Mul.</b>	<b>Note</b>
Performed by	ECU Integrator	1	
Consumes	ECU Extract	1	Application software requirements for NvM, especially SwcServiceDependency and ServiceNeeds.
Consumes	AUTOSAR Standardized ECU Configuration Parameter Definition	0..1	
Consumes	BSW Module Delivered Bundle	0..1	Predefined or recommended configuration values, vendor specific parameters, ServiceNeeds defined by BSW.
In/out	ECU Configuration Values	1	

**Table 3.226: Configure Mode Management**

### 3.6.1.10 Configure NvM

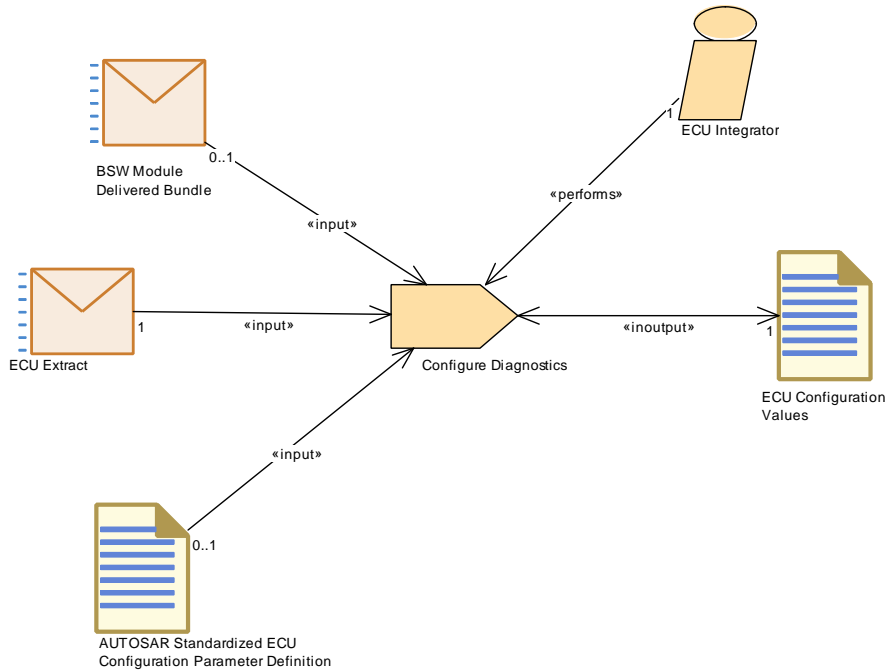


**Figure 3.110: Configure NvM**

<b>Task Definition</b>	<b>Configure NvM</b>		
<b>Package</b>	AUTOSAR Root::M2::Methodology::Methodology Library::Ecu::Tasks		
<b>Brief Description</b>	Configure the NvM stack for this ECU.		
<b>Description</b>	<p>Configure the NvM stack for this ECU. In the methodology library this is modeled as a single task (for simplicity) though in practice it may consist of several single tasks.</p> <p>Requirements for the configuration of NvM can be collected</p> <ul style="list-style-type: none"> <li>• from the upstream information about ServiceDependencies and ServiceNeeds in the ECU Extract and BSW Modules</li> <li>• from existing ECU configuration values</li> <li>• from Service Component Descriptions created for other Services (e.g. DEM)</li> </ul> <p>Meth.bindingTime = SystemDesignTime</p>		
<b>Relation Type</b>	<b>Related Element</b>	<b>Mul.</b>	<b>Note</b>
Performed by	<a href="#">ECU Integrator</a>	1	
Consumes	<a href="#">ECU Extract</a>	1	Application software requirements for NvM, especially SwcServiceDependency and ServiceNeeds.
Consumes	<a href="#">AUTOSAR Standardized ECU Configuration Parameter Definition</a>	0..1	
Consumes	<a href="#">BSW Module Delivered Bundle</a>	0..1	Predefined or recommended configuration values, vendor specific parameters, ServiceNeeds defined by BSW.
Consumes	<a href="#">Service Component Description</a>	0..*	The configuration of diagnostics, especially of the DEM, typically leads to the definition of additional data to be stored in NvM. One possibility to handle this is to create ServiceNeeds on the level ServiceComponentType which is then taken into account for the configuration of the NvM.
In/out	<a href="#">ECU Configuration Values</a>	1	

**Table 3.227: Configure NvM**

### 3.6.1.11 Configure Diagnostics



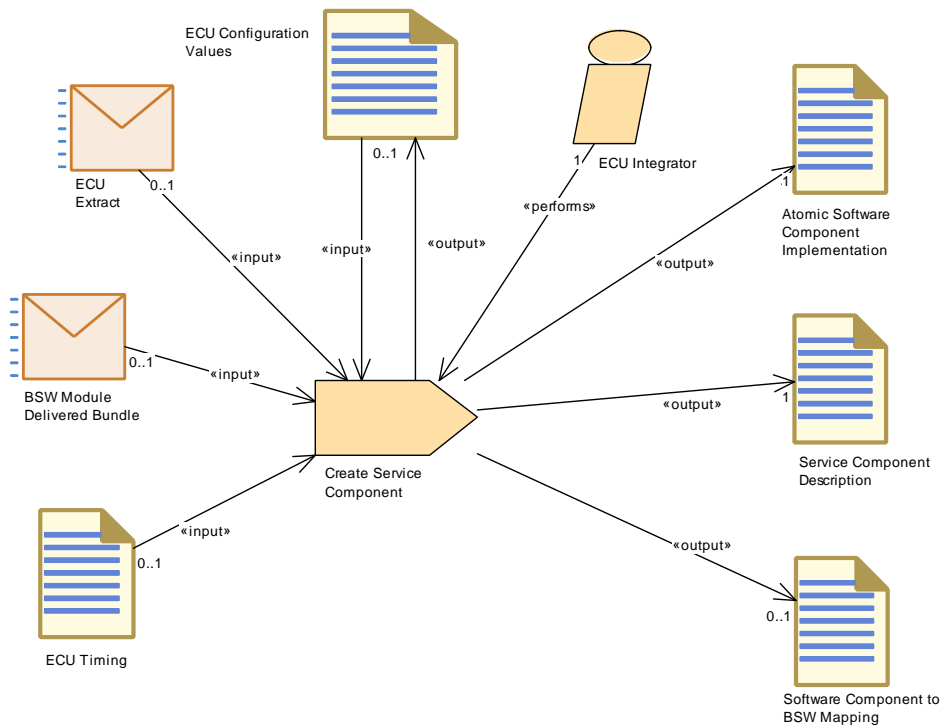
**Figure 3.111: Configure Diagnostics**

Task Definition	Configure Diagnostics		
Package	AUTOSAR Root::M2::Methodology::Methodology Library::Ecu::Tasks		
Brief Description	Configure the diagnostic modules for this ECU		
Description	Configure the diagnostic modules for this ECU. In the methodology library this is modeled as a single task (for simplicity) though in practice it may consist of several single tasks.  Meth.bindingTime = SystemDesignTime		
Relation Type	Related Element	Mul.	Note
Performed by	<a href="#">ECU Integrator</a>	1	
Consumes	<a href="#">ECU Extract</a>	1	Application software requirements for diagnostics, especially SwcServiceDependency and ServiceNeeds.
Consumes	<a href="#">AUTOSAR Standardized ECU Configuration Parameter Definition</a>	0..1	
Consumes	<a href="#">BSW Module Delivered Bundle</a>	0..1	Predefined or recommended configuration values, vendor specific parameters, ServiceNeeds defined by BSW.
In/out	<a href="#">ECU Configuration Values</a>	1	Configuration Values for DEM, DCM, DLT, FIM.

**Table 3.228: Configure Diagnostics**



### 3.6.1.12 Create Service Component



**Figure 3.112: Create Service Component**

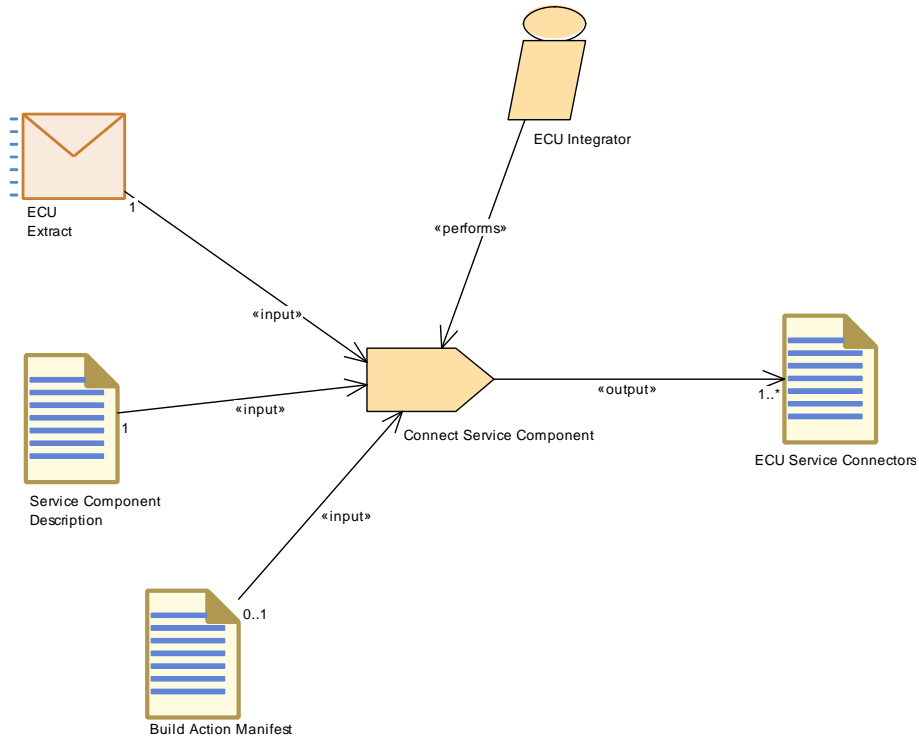


<i>Relation Type</i>	<i>Related Element</i>	<i>Mul.</i>	<i>Note</i>
<b>Task Definition</b>	<b>Create Service Component</b>		
<b>Package</b>	AUTOSAR Root::M2::Methodology::Methodology Library::Ecu::Tasks		
<b>Brief Description</b>	Create an instances for all required Service Components, configure them, create necessary ports and connectors to the respective application software components. This completes the ECU Software Composition.		
<b>Description</b>	<p>The ECU Extract contains all information about which components are mapped to a specific ECU. In a new "flat" Software Composition (meta-class RootSwCompositionPrototype) all other compositions have been removed. This has to be extended by an aggregation of the SwComponentPrototypes which describe the Services required by all application components on the ECU:</p> <ul style="list-style-type: none"> <li>• For each mapped SwComponentPrototype of type AtomicSwComponentType, the PortPrototypes requiring a particular Service and the associated SwcServiceDependency-s and ServiceNeeds are collected. Based on this information, a ServiceSwComponentType and its prototype is created exactly once per service with the corresponding number of PortPrototypes, thus that all service-type PortPrototypes of the Application Components have their PortPrototype counterpart on the ServiceSwComponentType.</li> <li>• RTE generation requires that an InternalBehavior and Implementation is created for each ServiceSwComponentType. In particular, the port defined argument values required for the usage of some service interfaces are configured, and the required RunnableEntities and RTEEvents are set up. It is also required to define a mapping between elements of the generated SWC and existing or generated elements of the BSW module description.</li> <li>• The evaluation of the input might result in further ServiceNeeds to be added to the generated InternalBehavior - for example a ServiceSwComponentType created for the DEM might include ServiceNeeds for NVRAM blocks. It is assumed, that such interdependencies are incrementally resolved within this task for all involved Service Components such that the outputs are consistent. Note that this is just one possibility to handle the situation - another option is to resolve the interdependencies only within the ECU configuration tasks (Configure Diagnostics, Configure NvM) without creating additional ServiceNeeds.</li> </ul> <p>Depending on the details of the configuration process for the particular module (namely which parts are generated or manually created), the steps described above can be done before, in parallel or after setting up the ECU configuration of the involved BSW modules. Likewise, the information used to create the ServiceSwComponentType(s) can come directly as input from the ECU Extract, or via the ECU Configuration. Therefore both artifacts are shown as optional input. The ECU Configuration is also an output, because a reference to the created SwComponentPrototype(s) must be entered here.</p> <p>The creation of connectors between the service and application components is a separate task..</p> <p>Meth.bindingTime = SystemDesignTime</p>		
<b>Relation Type</b>	<b>Related Element</b>	<b>Mul.</b>	<b>Note</b>

<b>Relation Type</b>	<b>Related Element</b>	<b>Mul.</b>	<b>Note</b>
Performed by	<a href="#">ECU Integrator</a>	1	
Consumes	<a href="#">BSW Module Delivered Bundle</a>	0..1	Required in order to define a mapping between SWC and BSW.  In addition, the Build Action Manifest may be used.
Consumes	<a href="#">ECU Configuration Values</a>	0..1	The creation of Service Component details may depend on ECU configuration values, especially for the DCM.
Consumes	<a href="#">ECU Extract</a>	0..1	Input information about the Service Ports and Service Dependencies of the software components.
Consumes	<a href="#">ECU Timing</a>	0..1	Additional information for fine tuning configuration decisions.
Produces	<a href="#">Atomic Software Component Implementation</a>	1	In order to generate the RTE, one needs to create a kind of dummy Implementation element for the Service Component, however this should not be filled with descriptive elements, e.g. resource consumption, as these are already defined by the Basic Software Module Implementation Description. Meth.bindingTime = SystemDesignTime
Produces	<a href="#">ECU Configuration Values</a>	1	Enter links to the created SwComponentPrototypes. Meth.bindingTime = SystemDesignTime
Produces	<a href="#">Service Component Description</a>	1	Meth.bindingTime = SystemDesignTime
Produces	<a href="#">Software Component to BSW Mapping</a>	0..1	Meth.bindingTime = SystemDesignTime

**Table 3.229: Create Service Component**

**3.6.1.13 Connect Service Component**

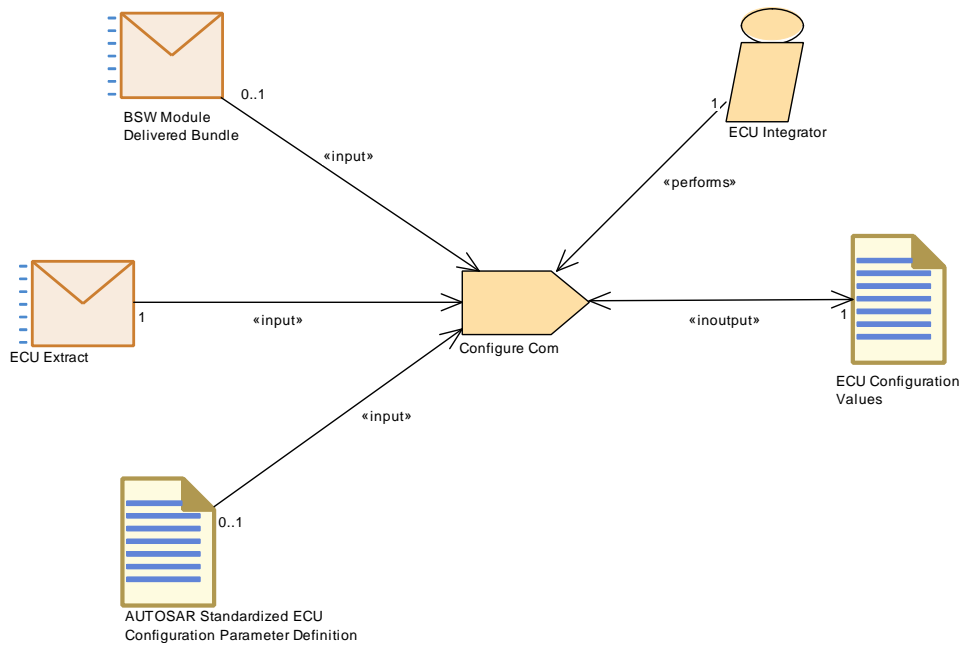


**Figure 3.113: Connect Service Component**

<b>Task Definition</b>	<b>Connect Service Component</b>		
<b>Package</b>	AUTOSAR Root::M2::Methodology::Methodology Library::Ecu::Tasks		
<b>Brief Description</b>			
<b>Description</b>	<p>In order to connect the "isService"-ports of the application components to a particular ServiceSwComponentType, AssemblyConnectorPrototypes are generated.</p> <p>The ECU Extract with its RootSwCompositionPrototype, extended by the Service Components and their connectors, finally serves as input for generating the RTE.</p> <p>Meth.bindingTime = SystemDesignTime</p>		
<b>Relation Type</b>	<b>Related Element</b>	<b>Mul.</b>	<b>Note</b>
Performed by	<a href="#">ECU Integrator</a>	1	
Consumes	<a href="#">ECU Extract</a>	1	Find the ports on the application side to be connected to the Service Component.
Consumes	<a href="#">Service Component Description</a>	1	Required in order to define the connector links to the ports on the BSW side.
Consumes	<a href="#">Build Action Manifest</a>	0..1	The task may be controlled by a Build Action Manifest.
Produces	<a href="#">ECU Service Connectors</a>	1..*	Meth.bindingTime = SystemDesignTime

**Table 3.230: Connect Service Component**

**3.6.1.14 Configure COM**

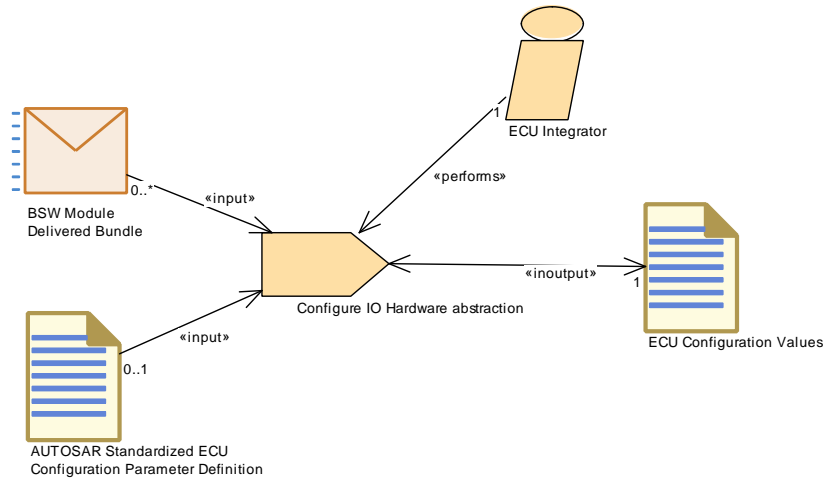


**Figure 3.114: Configure COM**

<b>Task Definition</b>	<b>Configure Com</b>		
<b>Package</b>	AUTOSAR Root::M2::Methodology::Methodology Library::Ecu::Tasks		
<b>Brief Description</b>	Configure the COM stack modules within an ECU		
<b>Description</b>	<p>The ECU Extract of the System Configuration contains the major part of information that is needed to configure the COM Stack modules (COM, PduR, CanIf, FrIf, LinIf, CanDrv, Fr, Lin, IPduM, TP, NM). Many parameter values of the ECU configuration can be derived from the ECU extract. The missing ECU specific configuration parameters that can not be derived from the System Description need to be set in this phase, e.g. Vendor-Specific Configuration Parameters. The following steps will be needed to perform the task : 1- Derive configuration parameter values from ECU extract : The System Template Specification describes rules on how the individual ECU configuration parameters shall be derived from the Upstream Templates (SWC Template, System Template, ECU Resource Template). This rules shall be followed. 2- Derive global PDUs from ECU extract : A global PDU has to be configured for each I-PDU flow and is added to the PDU collection of the module EcuC. Derived from the ECU Extract all PDUs that traverse through the COM Stack have to be created. 3- Create PDU References from the BSW Module PDUs to the global PDUs in the module EcuC:As soon as these global PDUs are created the references from the local module PDUs to the appropriate global PDUs need to be configured. 4-Set Missing and Vendor-Specific Parameter Values:Missing and Vendor-Specific Parameter Values need to be set 5-Set BSW Module specific PDU handle IDs:The last step is the assignment of the actual values for the Handle IDs. This can be achieved by an automatic tool which might be run directly before the generation of the module.</p> <p>Meth.bindingTime = SystemDesignTime</p>		
<b>Relation Type</b>	<b>Related Element</b>	<b>Mul.</b>	<b>Note</b>
Performed by	<a href="#">ECU Integrator</a>	1	
Consumes	<a href="#">ECU Extract</a>	1	
Consumes	<a href="#">AUTOSAR Standardized ECU Configuration Parameter Definition</a>	0..1	
Consumes	<a href="#">BSW Module Delivered Bundle</a>	0..1	
In/out	<a href="#">ECU Configuration Values</a>	1	

**Table 3.231: Configure Com**

### 3.6.1.15 Configure IO Hardware Abstraction



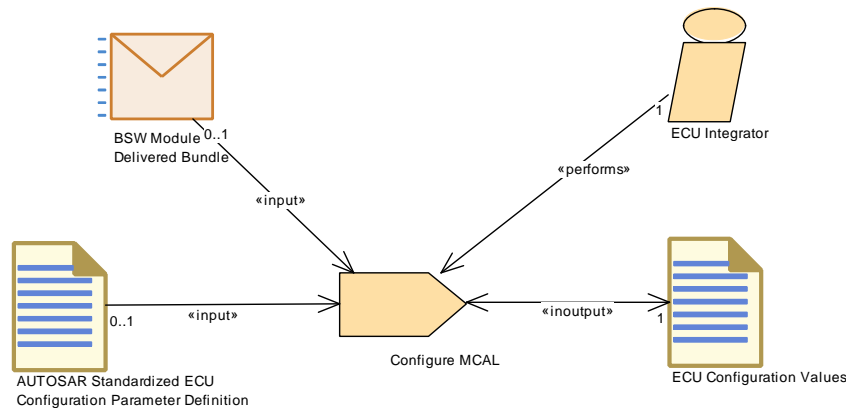
**Figure 3.115: Configure IO Hardware Abstraction**

<b>Task Definition</b>	<b>Configure IO Hardware abstraction</b>		
<b>Package</b>	AUTOSAR Root::M2::Methodology::Methodology Library::Ecu::Tasks		
<b>Brief Description</b>	Configure I/O Hardware Abstraction		
<b>Description</b>	Configure the I/O Hardware Abstraction modules.  Meth.bindingTime = SystemDesignTime		
<b>Relation Type</b>	<b>Related Element</b>	<b>Mul.</b>	<b>Note</b>
Performed by	<a href="#">ECU Integrator</a>	1	
Consumes	<a href="#">AUTOSAR Standardized ECU Configuration Parameter Definition</a>	0..1	
Consumes	<a href="#">BSW Module Delivered Bundle</a>	0..*	
In/out	<a href="#">ECU Configuration Values</a>	1	

**Table 3.232: Configure IO Hardware abstraction**



### 3.6.1.16 Configure MCAL

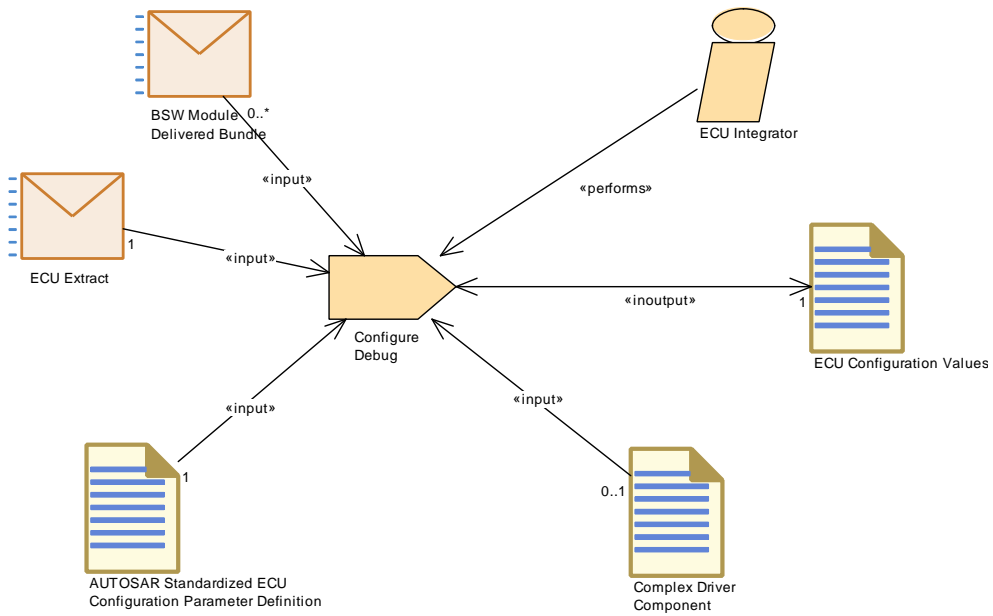


**Figure 3.116: Configure MCAL**

<b>Task Definition</b>	<b>Configure MCAL</b>		
<b>Package</b>	AUTOSAR Root::M2::Methodology::Methodology Library::Ecu::Tasks		
<b>Brief Description</b>	Configure the Microcontroller Abstraction Layer for this ECU.		
<b>Description</b>	Configure the Microcontroller Abstraction Layer for this ECU.  Meth.bindingTime = SystemDesignTime		
<b>Relation Type</b>	<b>Related Element</b>	<b>Mul.</b>	<b>Note</b>
Performed by	<a href="#">ECU Integrator</a>	1	
Consumes	<a href="#">AUTOSAR Standardized ECU Configuration Parameter Definition</a>	0..1	
Consumes	<a href="#">BSW Module Delivered Bundle</a>	0..1	
In/out	<a href="#">ECU Configuration Values</a>	1	

**Table 3.233: Configure MCAL**

**3.6.1.17 Configure Debug**



**Figure 3.117: Configure Debug**

<b>Task Definition</b>	<b>Configure Debug</b>		
<b>Package</b>	AUTOSAR Root::M2::Methodology::Methodology Library::Ecu::Tasks		
<b>Brief Description</b>	Configure the AUTOSARdebugger Module		
<b>Description</b>	<p>The AUTOSAR Debugger Module (Dbg) handles the interaction between the Debugger Host and the AUTOSAR ECU. It is split into the "core" and the "communication" part. Each BSW has an ID &amp; Each API has an ID. (e.g. module 84, api 5). The Debugger Host (shortly called Host) may be connected via</p> <ol style="list-style-type: none"> <li>Existing communication buses which are also used for the functional behavior of the ECU.</li> <li>A dedicated debugging line which is not used for functional behavior of the ECU. (e.g. via Complex Driver)</li> </ol> <p>Since Dbg needs information on the debugged software, it is configured quite late in the ECU Configuration steps. Other modules must be configured before the debug. Even after changes of the OS configuration, Dbg needs to be updated as well.</p> <p>The input to the Dbg ECU Configuration are: 1. ECU Configuration Values description</p> <ul style="list-style-type: none"> <li>If existing communication buses are used, Dbg needs to transmit and receive I-Pdus which then are handled in the COM-Stack. Those I-Pdus need to be created / referenced.</li> <li>Usage of OsAlarm</li> <li>Usage of GptChannel (optional, for time stamping)</li> </ul> <p>2. BSW Module Descriptions of the debugged modules in order to identify which variables / functions can be debugged. Prerequisites are: The variables need to be placed in global accessible memory; the data types of these variables need to be defined in the header files.</p> <p>Meth.bindingTime = SystemDesignTime</p>		
<b>Relation Type</b>	<b>Related Element</b>	<b>Mul.</b>	<b>Note</b>
Performed by	<a href="#">ECU Integrator</a>	1	
Consumes	<a href="#">AUTOSAR Standardized ECU Configuration Parameter Definition</a>	1	
Consumes	<a href="#">ECU Extract</a>	1	
Consumes	<a href="#">Complex Driver Component</a>	0..1	
Consumes	<a href="#">BSW Module Delivered Bundle</a>	0..*	
In/out	<a href="#">ECU Configuration Values</a>	1	

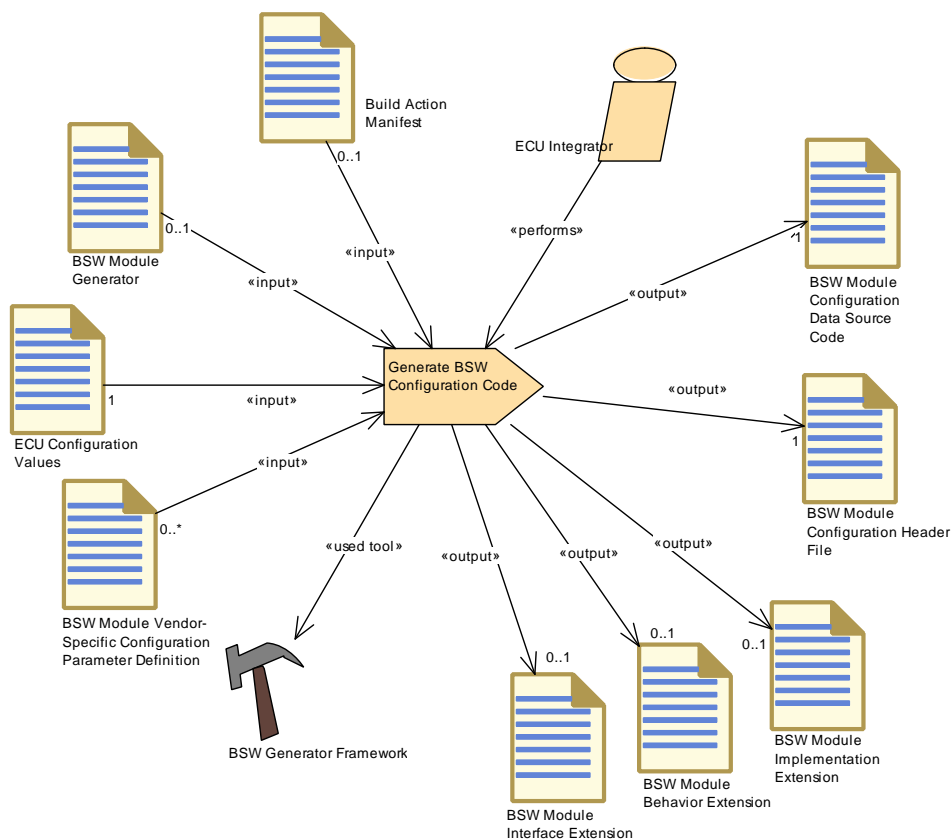
**Table 3.234: Configure Debug**

The task to configure the debug module consists of the following detailed steps (not shown in the table above due to formatting reasons):

1. RTE VFB-Tracing if needed : The RTE ECU Configuration shall contain a "RteVfbTraceClientPrefix = Dbg".
2. Periodic Data Collection if needed : Configure the reference to the OsAlarm which will invoke the periodic data collection. Note that the OsAlarm needs to be configured in the Os ECU Configuration (before or after).
3. Timestamp Measurement if needed : Configure the size of the timestamp (16 or 32 bit) then configure the reference to the GptChannel which will provide the timestamp information. Note that the GptChannel needs to be configured in the Gpt ECU Configuration (before or after).
4. Configure the Buffering of the Debug : Size, Strategy (last-is-best/queued) and behavior.
5. AUTOSAR Communication stack : Configure the used Tx and Rx I-Pdus, the corresponding I-Pdus need to be configured in the EcuC Module and the rest of the COM-Stack. If Complex Driver is used for communication, configure Complex Driver.
6. Configure the to be debugged elements - BSW only - Prerequisite: The BSW Module shall be already configured and generated therefore there is an updated BSW-Module Description available of the actually generated BSW Module. The first work will be to get the list of traceable API calls out of the BSWMD of the BSW Module. Then select which API calls shall be traced (e.g. call "CanIf\_Transmit" from the "PduR" to the "CanIf") and configure each trace function: buffering, timestamp.
7. Configure the to be debugged elements - RTE only - Prerequisite: The RTE has been generated, therefore there is an updated BSW-Module Description available of the actually generated RTE. Attention: The RTE shall not be re-configured after the Dbg has been configured, otherwise the Dbg needs to be re-configured as well. The first work will be to get the list of available VFB-Trace functions out of the BSWMD of the RTE. Then, Select which VFB-Trace functions shall be traced (e.g. Rte\_Dbg\_Runnable\_component\_re\_Start() ), configure each VFB-Trace function: Buffering, Timestamp, in case of Rte-Com tracing: which Com-Signal is traced, in case of VFB-Signal tracing: which VariablePrototype is traced, in case of Client-Server tracing: which OperationPrototype is traced, in case of RunnableEntity tracing: which RunnableEntity is traced.
8. Configure the to be debugged elements - BSW and RTE - Prerequisite: The RTE has been generated, therefore there is an updated BSW-Module Description available . Attention: The RTE shall not be re-configured after the Dbg has been configured. The first step will be out of the BSWMD of the BSW and the RTE to extract the list of available debuggable variables and provide it to the Dbg configuration. Then, select which variables shall be debugged (e.g. internal states of the module), configure each individual DID with symbol name, optional size, optional absolute address, buffering, timestamp, collection frequency Note: Size and address (e.g. for an ECU register) could be resolved by the linker, hence optional here.

9. Generate the Dbg Module: Generate the c and header files of the Dbg, use the additional header files of the to be debugged modules in order to perform a "sizeof()" operation in the compiler, compile Dbg Module (and other to-be-debugged modules), analyze the object file in order to update the ECU Configuration Values description which additional information the length information for each DID (out of the sizeof() operation). Host application uses this information (ECU configuration of debug module, BSW module description of the debug module and the to-be-debugged modules) in order to send the correct DIDs.

### 3.6.1.18 Generate BSW Configuration Code and Model Extensions

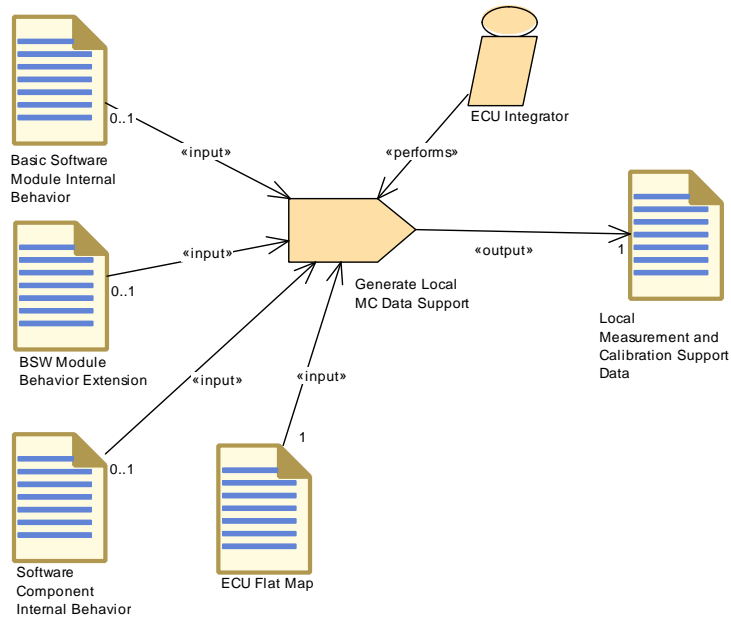


**Figure 3.118: Generate BSW Code and model extensions**

<b>Task Definition</b>	<b>Generate BSW Configuration Code</b>		
<b>Package</b>	AUTOSAR Root::M2::Methodology::Methodology Library::Ecu::ECU Config Classes::Tasks		
<b>Brief Description</b>	Generate source code which implements configuration data for link- or compile-time configuration.		
<b>Description</b>	<p>A generator reads the relevant parameters from the ECU Configuration Description and creates a separate code file that implements the specified configuration. This task is used for link-time configuration, i.e. the configuration code can be produced at link-time of the core code or for compile-time configuration, if the configuration code cannot be put into a header file (e.g. for tables), even if the core code and the configuration code shall be compiled at the same time.</p> <p>A header file may be produced in addition, to declare the data.</p> <p>Furthermore the generator may produce extensions of the BSW module description artifacts as a result of configuration parameter values which are set at integration time.</p>		
<b>Relation Type</b>	<b>Related Element</b>	<b>Mul.</b>	<b>Note</b>
Performed by	<a href="#">ECU Integrator</a>	1	
Consumes	<a href="#">ECU Configuration Values</a>	1	
Consumes	<a href="#">BSW Module Generator</a>	0..1	This is an input in case a generator framework is used which has to run some module specific generator code.
Consumes	<a href="#">Build Action Manifest</a>	0..1	The task may be controlled by a Build Action Manifest.
Consumes	<a href="#">BSW Module Vendor-Specific Configuration Parameter Definition</a>	0..*	
Produces	<a href="#">BSW Module Configuration Data Source Code</a>	1	
Produces	<a href="#">BSW Module Configuration Header File</a>	1	
Produces	<a href="#">BSW Module Behavior Extension</a>	0..1	
Produces	<a href="#">BSW Module Implementation Extension</a>	0..1	
Produces	<a href="#">BSW Module Interface Extension</a>	0..1	
Used tool	<a href="#">BSW Generator Framework</a>	1	

**Table 3.235: Generate BSW Configuration Code**

**3.6.1.19 Generate Local MC Data Support**



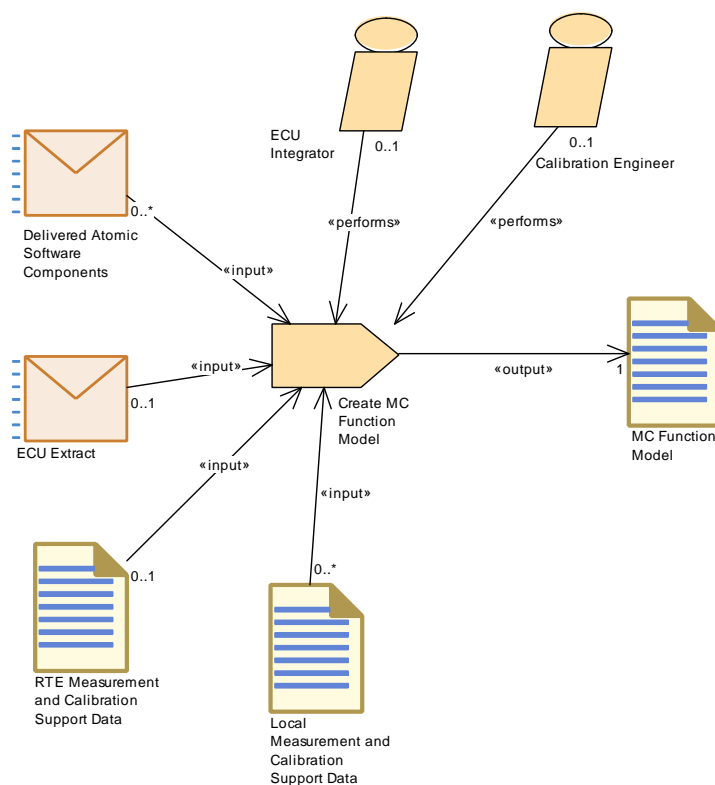
**Figure 3.119: Generate Local MC Data Support**

<b>Task Definition</b>	<b>Generate Local MC Data Support</b>		
<b>Package</b>	AUTOSAR Root::M2::Methodology::Methodology Library::Ecu::Tasks		
<b>Brief Description</b>	Generate Local MC Support Data		
<b>Description</b>	<p>Generate the support data needed for measurement and calibration of those parameters and variables (roles constantMemory and staticMemory), which are owned locally by the code of a module or component (in contrast to those, which are owned by the RTE).</p> <p>The declaration of local variables/parameters is read from the Internal Behavior of either a BSW module or an Atomic Software Component, therefore these can be considered as alternative inputs. The ECU Flat Map is needed as input in order to resolve possible name conflicts.</p> <p>This task can be combined with RTE generation for practical reasons, but it is considered as an independent task.</p> <p>Note that calibration data that need software emulation support by the RTE cannot be handled by this task; they need to be processed by the task Generate RTE.</p> <p>Meth.bindingTime = CodeGenerationTime</p>		
<b>Relation Type</b>	<b>Related Element</b>	<b>Mul.</b>	<b>Note</b>
Performed by	ECU Integrator	1	
Consumes	ECU Flat Map	1	Meth.bindingTime = SystemDesignTime
Consumes	BSW Module Behavior Extension	0..1	Meth.bindingTime = SystemDesignTime
Consumes	Basic Software Module Internal Behavior	0..1	Meth.bindingTime = SystemDesignTime

Relation Type	Related Element	Mul.	Note
Consumes	Software Component Internal Behavior	0..1	Meth.bindingTime = SystemDesignTime
Produces	Local Measurement and Calibration Support Data	1	Meth.bindingTime = CodeGenerationTime

**Table 3.236: Generate Local MC Data Support**

**3.6.1.20 Create MC Function Model**



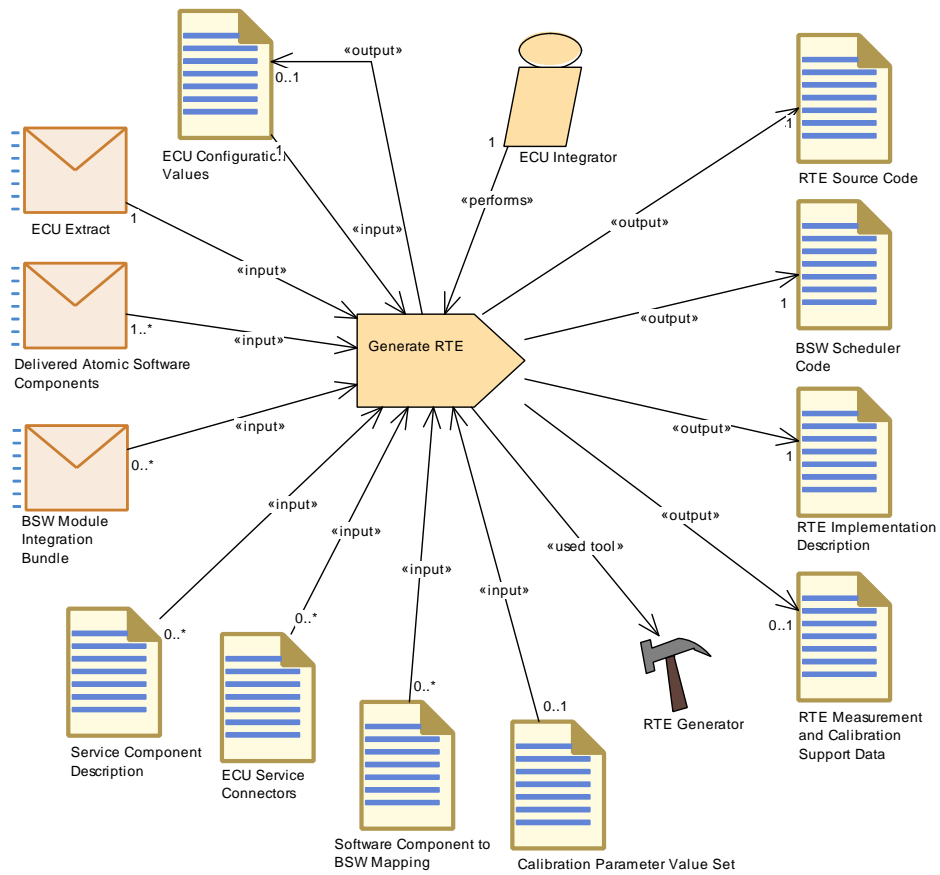
**Figure 3.120: Create MC Function Model**



<b>Task Definition</b>	<b>Create MC Function Model</b>		
<b>Package</b>	AUTOSAR Root::M2::Methodology::Methodology Library::Ecu::Tasks		
<b>Brief Description</b>	Define a model of McFunctions.		
<b>Description</b>	<p>Create (manually or by generator) a functional model of measurement and calibration data on an ECU. Such a model may be derived from the logical structure of software components, ports etc. but the rules for this transformation are not standardized.</p> <p>This task may be performed before the RTE code is generated. Then the model will be based on the data defined in the ECU Flat Map.</p> <p>The task may also be performed at the same time as or after the generation of Measurement and Calibration Support Data. In this case it is possible (but not mandatory) to base the model on these support data only.</p> <p>The task may be supported by the RTE generator (not a standardized feature) or another tool.</p>		
<b>Relation Type</b>	<b>Related Element</b>	<b>Mul.</b>	<b>Note</b>
Performed by	Calibration Engineer	0..1	
Performed by	ECU Integrator	0..1	
Consumes	ECU Extract	0..1	<p>The ECU Flat Map can be used to define references to variables and parameters which are later visible in A2L.</p> <p>Furthermore, the ECU Extract can be used to find the relevant software components.</p>
Consumes	RTE Measurement and Calibration Support Data	0..1	Used if the MC Function Model shall refer to McDataInstances allocated by the RTE.
Consumes	Delivered Atomic Software Components	0..*	The component model may be used to derive an MC Function Model.
Consumes	Local Measurement and Calibration Support Data	0..*	Used if the MC Function Model shall refer to McDataInstances allocated by BSW modules without RTE support.
Produces	MC Function Model	1	

**Table 3.237: Create MC Function Model**

**3.6.1.21 Generate RTE**



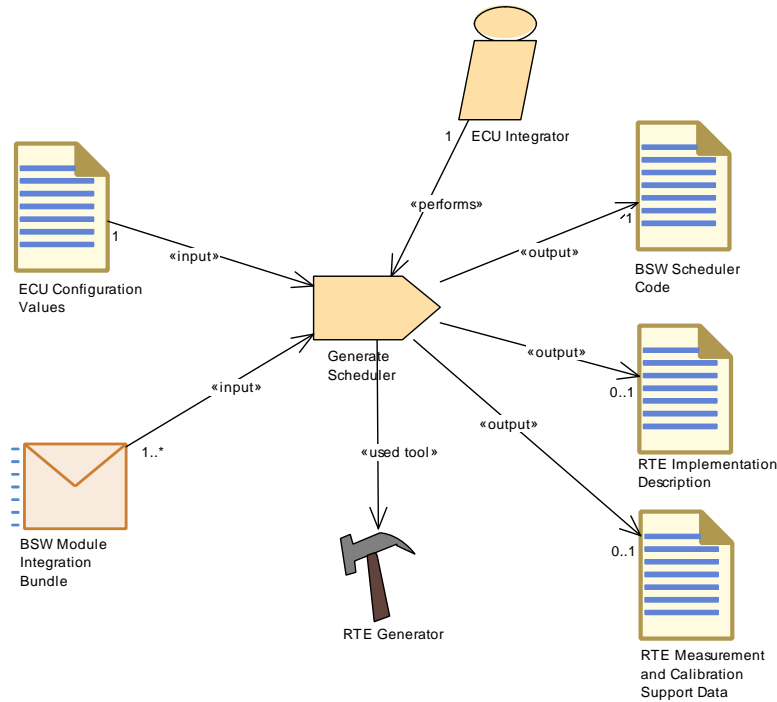
**Figure 3.121: Generate RTE**

<b>Task Definition</b>	<b>Generate RTE</b>		
<b>Package</b>	AUTOSAR Root::M2::Methodology::Methodology Library::Ecu::Tasks		
<b>Brief Description</b>	Generate the RTE and several further artifacts.		
<b>Description</b>	<p>Generate the RTE and several further artifacts from the input XML descriptions in the scope of a given ECU:</p> <ul style="list-style-type: none"> <li>• RTE Core Source Code</li> <li>• BSW Scheduler Code</li> <li>• RTE Implementation Description</li> <li>• RTE Measurement and Calibration Support Data</li> </ul> <p>In an optional mode, this task can also write into the ECU configuration, especially for the configuration of the OS. This mode is used to pre-configure parts of the ECU configuration. It shall support the integrator in setting up the configuration in an iterative way.</p> <p>In the so-called strict mode, the ECU configuration is not changed but assumed to be complete. This mode shall be used before the final build. A PredefinedVariant in the input data (referred in the EcuC configuration, see task Configure EcuC) can be used to bind variation points at code generation time. For variation points with latest binding time "code generation time" this is mandatory. Unbound variation points can still be present in the generated code.</p> <p>Meth.bindingTime = CodeGenerationTime</p>		
<b>Relation Type</b>	<b>Related Element</b>	<b>Mul.</b>	<b>Note</b>
Performed by	<a href="#">ECU Integrator</a>	1	
Consumes	<a href="#">ECU Configuration Values</a>	1	Meth.bindingTime = SystemDesignTime
Consumes	<a href="#">ECU Extract</a>	1	<p>Find the VFB description of all Atomic Software Components on this ECU and the relevant parts of the system description.</p> <p>The ECU Flat Map is also an input. Meth.bindingTime = SystemDesignTime</p>
Consumes	<a href="#">Delivered Atomic Software Components</a>	1..*	<p>Required input:</p> <ul style="list-style-type: none"> <li>• References to all component implementation descriptions on this ECU</li> <li>• SwcInternalBehavior which was used in the contract phase of the software components on this ECU</li> <li>• (optional) Software Component to BSW Mapping</li> </ul> <p>Meth.bindingTime = SystemDesignTime</p>
Consumes	<a href="#">Calibration Parameter Value Set</a>	0..1	Meth.bindingTime = SystemDesignTime

<b>Relation Type</b>	<b>Related Element</b>	<b>Mul.</b>	<b>Note</b>
Consumes	<a href="#">BSW Module Integration Bundle</a>	0..*	Input for BSW scheduling, BSW mode and trigger declaration, BSW exclusive areas, BSW calibration parameters that need RTE support (for software emulation).  Optionally, a Build Action Manifest maybe be used to control the generator steps. Meth.bindingTime = SystemDesignTime
Consumes	<a href="#">ECU Service Connectors</a>	0..*	Meth.bindingTime = SystemDesignTime
Consumes	<a href="#">Service Component Description</a>	0..*	Meth.bindingTime = SystemDesignTime
Consumes	<a href="#">Software Component to BSW Mapping</a>	0..*	This input is explicitly stated because the mapping may be created during ECU integration and thus is not necessarily part of the Delivered Atomic Software Components. Meth.bindingTime = SystemDesignTime
Produces	<a href="#">BSW Scheduler Code</a>	1	Meth.bindingTime = CodeGenerationTime
Produces	<a href="#">RTE Implementation Description</a>	1	Meth.bindingTime = CodeGenerationTime
Produces	<a href="#">RTE Source Code</a>	1	Meth.bindingTime = CodeGenerationTime
Produces	<a href="#">ECU Configuration Values</a>	0..1	Optional output for the configuration of the OS. Meth.bindingTime = CodeGenerationTime
Produces	<a href="#">RTE Measurement and Calibration Support Data</a>	0..1	Meth.bindingTime = CodeGenerationTime
Used tool	<a href="#">RTE Generator</a>	1	

**Table 3.238: Generate RTE**

**3.6.1.22 Generate Scheduler**



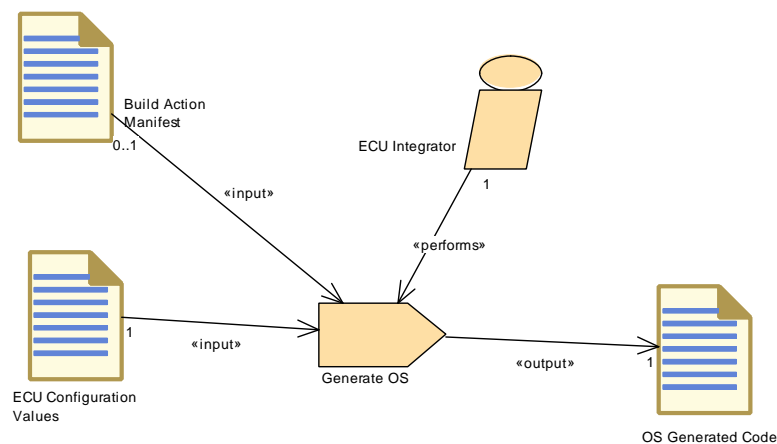
**Figure 3.122: Generate Scheduler**

<b>Task Definition</b>	<b>Generate Scheduler</b>		
<b>Package</b>	AUTOSAR Root::M2::Methodology::Methodology Library::Ecu::Tasks		
<b>Brief Description</b>	Generate the BSW Scheduler		
<b>Description</b>	Optional task of the RTE generator which only produces the code of the BSW Scheduler and related artifacts.  Meth.bindingTime = CodeGenerationTime		
<b>Relation Type</b>	<b>Related Element</b>	<b>Mul.</b>	<b>Note</b>
Performed by	<a href="#">ECU Integrator</a>	1	
Consumes	<a href="#">ECU Configuration Values</a>	1	Configuration values for the BSW Scheduler (subset of RTE configuration).  Meth.bindingTime = SystemDesignTime
Consumes	<a href="#">BSW Module Integration Bundle</a>	1..*	Input for BSW scheduling, BSW mode and trigger declaration, BSW exclusive areas, BSW calibration parameters that need support for software emulation.  Optionally, a Build Action Manifest maybe be used to control the generator steps. Meth.bindingTime = SystemDesignTime
Produces	<a href="#">BSW Scheduler Code</a>	1	Meth.bindingTime = CodeGenerationTime

Relation Type	Related Element	Mul.	Note
Produces	<a href="#">RTE Implementation Description</a>	0..1	Creates a subset of the RTE implementation description that contains only the description of data owned by the BSW Scheduler. Meth.bindingTime = CodeGenerationTime
Produces	<a href="#">RTE Measurement and Calibration Support Data</a>	0..1	Creates a subset of the measurement & calibration support data related only to the data owned by the BSW Scheduler. Meth.bindingTime = CodeGenerationTime
Used tool	<a href="#">RTE Generator</a>	1	

**Table 3.239: Generate Scheduler**

### 3.6.1.23 Generate OS

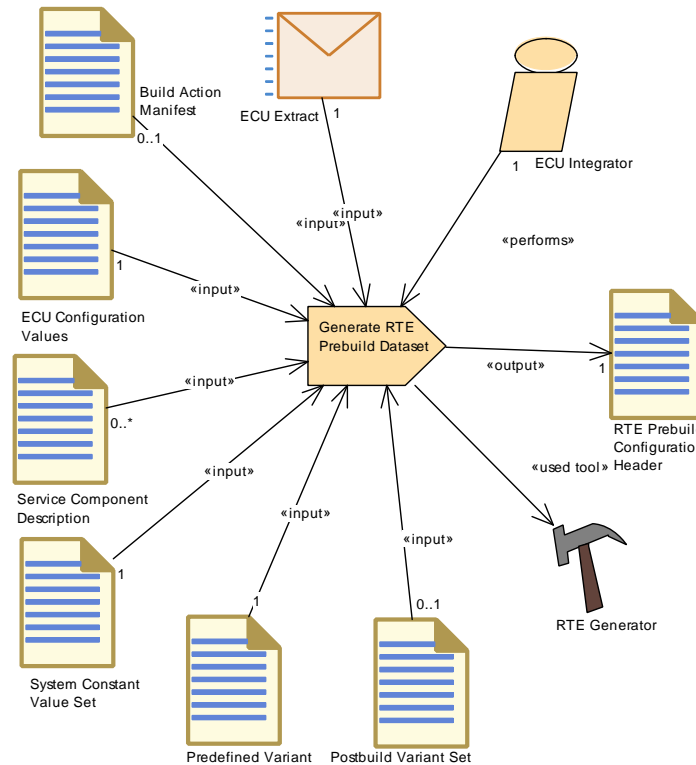


**Figure 3.123: Generate OS**

Task Definition	Generate OS		
Package	AUTOSAR Root::M2::Methodology::Methodology Library::Ecu::Tasks		
Brief Description	Generate the OS Generated Code files		
Description	Generate the OS Generated Code files using the OS configuration values from the ECU Configuration .  Meth.bindingTime = CodeGenerationTime		
Relation Type	Related Element	Mul.	Note
Performed by	<a href="#">ECU Integrator</a>	1	
Consumes	<a href="#">ECU Configuration Values</a>	1	Meth.bindingTime = SystemDesignTime
Consumes	<a href="#">Build Action Manifest</a>	0..1	The task may be controlled by a Build Action Manifest.
Produces	<a href="#">OS Generated Code</a>	1	Meth.bindingTime = CodeGenerationTime

**Table 3.240: Generate OS**

### 3.6.1.24 Generate RTE Prebuild Dataset



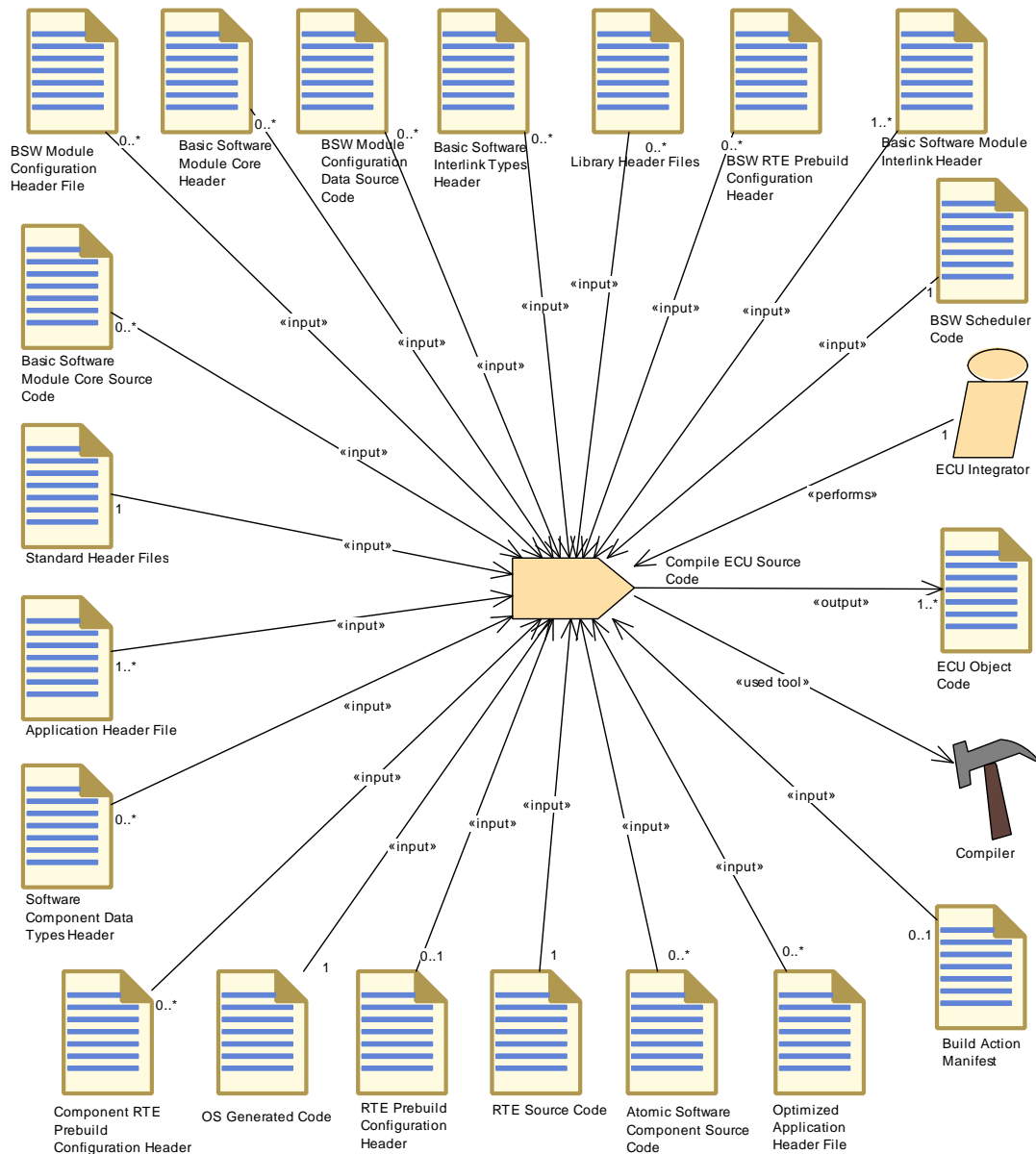
**Figure 3.124: Generate RTE Prebuild Dataset**

<b>Task Definition</b>	<b>Generate RTE Prebuild Dataset</b>		
<b>Package</b>	AUTOSAR Root::M2::Methodology::Methodology Library::Ecu::Tasks		
<b>Brief Description</b>	Prebuild Data Set Generation Phase for the RTE: It binds all variations which are later than code generation time		
<b>Description</b>	<p>Prebuild Data Set Generation Phase for the RTE: It binds all variations which are later than code generation time but before build time. The output is a configuration header which is used for the build.</p> <p>The actually supported variant are defined by the PredefinedVariant referred in the EcuC configuration (see task Configure EcuC).</p> <p>Meth.bindingTime = PreCompileTime</p>		
<b>Relation Type</b>	<b>Related Element</b>	<b>Mul.</b>	<b>Note</b>
Performed by	<a href="#">ECU Integrator</a>	1	
Consumes	<a href="#">ECU Configuration Values</a>	1	find the Predefined Variant to be used Meth.bindingTime = CodeGenerationTime
Consumes	<a href="#">ECU Extract</a>	1	Meth.bindingTime = CodeGenerationTime
Consumes	<a href="#">Predefined Variant</a>	1	
Consumes	<a href="#">System Constant Value Set</a>	1	
Consumes	<a href="#">Build Action Manifest</a>	0..1	The task may be controlled by a Build Action Manifest.

Relation Type	Related Element	Mul.	Note
Consumes	Postbuild Variant Set	0..1	
Consumes	Service Component Description	0..*	Meth.bindingTime = CodeGenerationTime
Produces	RTE Prebuild Configuration Header	1	Meth.bindingTime = PreCompileTime
Used tool	RTE Generator	1	

**Table 3.241: Generate RTE Prebuild Dataset**

### 3.6.1.25 Compile ECU Source Code



**Figure 3.125: Compile ECU Source Code**

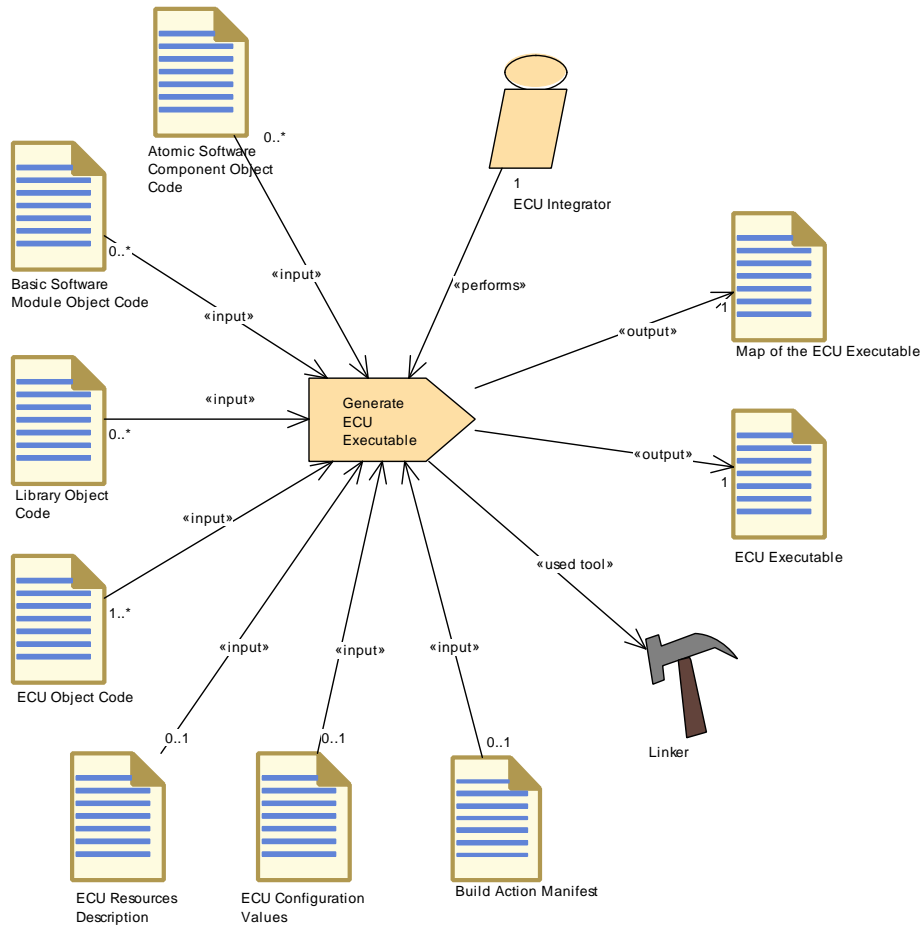


<b>Task Definition</b>	<b>Compile ECU Source Code</b>		
<b>Package</b>	AUTOSAR Root::M2::Methodology::Methodology Library::Ecu::Tasks		
<b>Brief Description</b>	Compile Source Code for an ECU		
<b>Description</b>	<p>Compile all the source code required for ECU integration, i.e. all source code except the code which is delivered as object code.</p> <p>Meth.bindingTime = CompileTime</p>		
<b>Relation Type</b>	<b>Related Element</b>	<b>Mul.</b>	<b>Note</b>
Performed by	ECU Integrator	1	
Consumes	BSW Scheduler Code	1	Meth.bindingTime = CodeGenerationTime
Consumes	OS Generated Code	1	Meth.bindingTime = CodeGenerationTime
Consumes	RTE Source Code	1	Meth.bindingTime = CodeGenerationTime
Consumes	Standard Header Files	1	Meth.bindingTime = CodeGenerationTime
Consumes	Application Header File	1..*	Meth.bindingTime = CodeGenerationTime
Consumes	Basic Software Module Interlink Header	1..*	Meth.bindingTime = CodeGenerationTime
Consumes	Build Action Manifest	0..1	The task may be controlled by a Build Action Manifest.
Consumes	RTE Prebuild Configuration Header	0..1	Meth.bindingTime = PreCompileTime
Consumes	Atomic Software Component Source Code	0..*	Meth.bindingTime = CodeGenerationTime
Consumes	BSW Module Configuration Data Source Code	0..*	Meth.bindingTime = CodeGenerationTime
Consumes	BSW Module Configuration Header File	0..*	Meth.bindingTime = CodeGenerationTime
Consumes	BSW RTE Prebuild Configuration Header	0..*	Meth.bindingTime = PreCompileTime
Consumes	Basic Software Interlink Types Header	0..*	Meth.bindingTime = CodeGenerationTime
Consumes	Basic Software Module Core Header	0..*	Meth.bindingTime = CodeGenerationTime
Consumes	Basic Software Module Core Source Code	0..*	Meth.bindingTime = CodeGenerationTime
Consumes	Component RTE Prebuild Configuration Header	0..*	Meth.bindingTime = CodeGenerationTime

Relation Type	Related Element	Mul.	Note
Consumes	Library Header Files	0..*	Meth.bindingTime = CodeGenerationTime
Consumes	Optimized Application Header File	0..*	Meth.bindingTime = CodeGenerationTime
Consumes	Software Component Data Types Header	0..*	Meth.bindingTime = CodeGenerationTime
Produces	ECU Object Code	1..*	Meth.bindingTime = CompileTime
Used tool	Compiler	1	

**Table 3.242: Compile ECU Source Code**

**3.6.1.26 Generate ECU Executable**



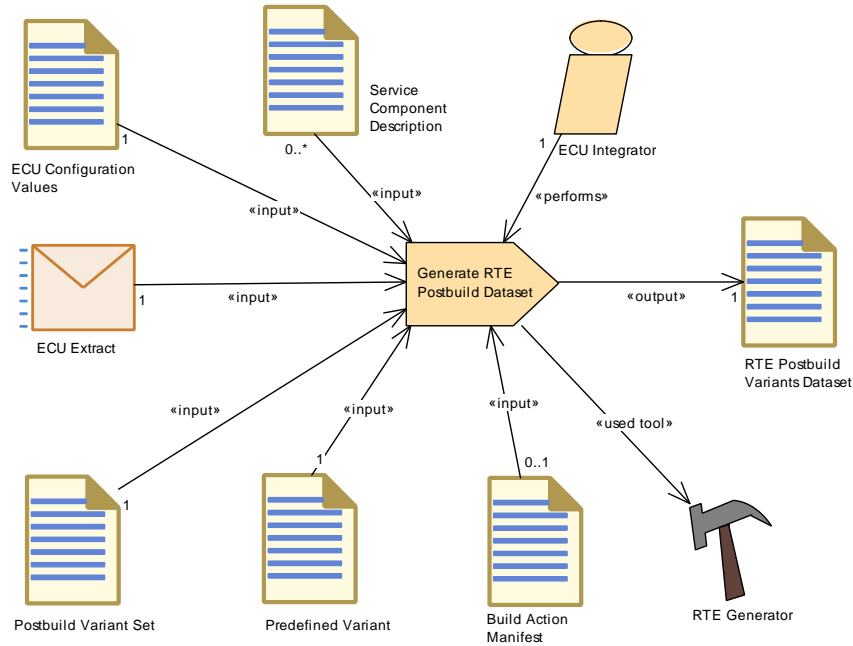
**Figure 3.126: Generate ECU Executable**

<b>Task Definition</b>	<b>Generate ECU Executable</b>		
<b>Package</b>	AUTOSAR Root::M2::Methodology::Methodology Library::Ecu::Tasks		
<b>Brief Description</b>	Generate the executable code of the ECU out of the object files and linker configuration.		
<b>Description</b>	<p>The steps to generate the code for an ECU resemble today's development practice. However, it is important to note that this activity is more than a simple linker step. Information from the ECU Configuration Description might be used to generate specially configured executable software. The ECU Configuration Description is needed as input to the Generate Executable activity, because it contains the information which BSW modules and SWC implementations are used to create the executable and further information about the memory mapping.</p> <p>The output of this activity is the ECU Executable and the Map of Executable (which is typically the log file from linking the ECU Executable).</p> <p>The detailed input and output formats of this task are not standardized by AUTOSAR, therefore this task is only included for informative purposes. Note that ECU Configuration is shown as an input to get the overall picture, however in practice more specific artifacts (e.g. linker settings, make file etc.) will have to be generated out of the ECU configuration before the actual software build can be started. Especially, the information about the mapping of the physical memory sections to the memory section used in the software, which is described in the so-called EcuC parameter values, is needed in order to generate the linker settings.</p> <p>Meth.bindingTime = LinkTime</p>		
<b>Relation Type</b>	<b>Related Element</b>	<b>Mul.</b>	<b>Note</b>
Performed by	<a href="#">ECU Integrator</a>	1	
Consumes	<a href="#">ECU Object Code</a>	1..*	from generated or delivered source code Meth.bindingTime = CompileTime
Consumes	<a href="#">Build Action Manifest</a>	0..1	The task may be controlled by a Build Action Manifest.
Consumes	<a href="#">ECU Configuration Values</a>	0..1	may be used to set up build environment Meth.bindingTime = CompileTime
Consumes	<a href="#">ECU Resources Description</a>	0..1	may be used to set up build environment Meth.bindingTime = CompileTime
Consumes	<a href="#">Atomic Software Component Object Code</a>	0..*	Meth.bindingTime = CompileTime
Consumes	<a href="#">Basic Software Module Object Code</a>	0..*	for object code delivery Meth.bindingTime = CompileTime
Consumes	<a href="#">Library Object Code</a>	0..*	for object code delivery Meth.bindingTime = CompileTime
Produces	<a href="#">ECU Executable</a>	1	Meth.bindingTime = LinkTime
Produces	<a href="#">Map of the ECU Executable</a>	1	Meth.bindingTime = LinkTime
Used tool	<a href="#">Linker</a>	1	

Relation Type	Related Element	Mul.	Note
---------------	-----------------	------	------

**Table 3.243: Generate ECU Executable**

**3.6.1.27 Generate RTE Postbuild Dataset**



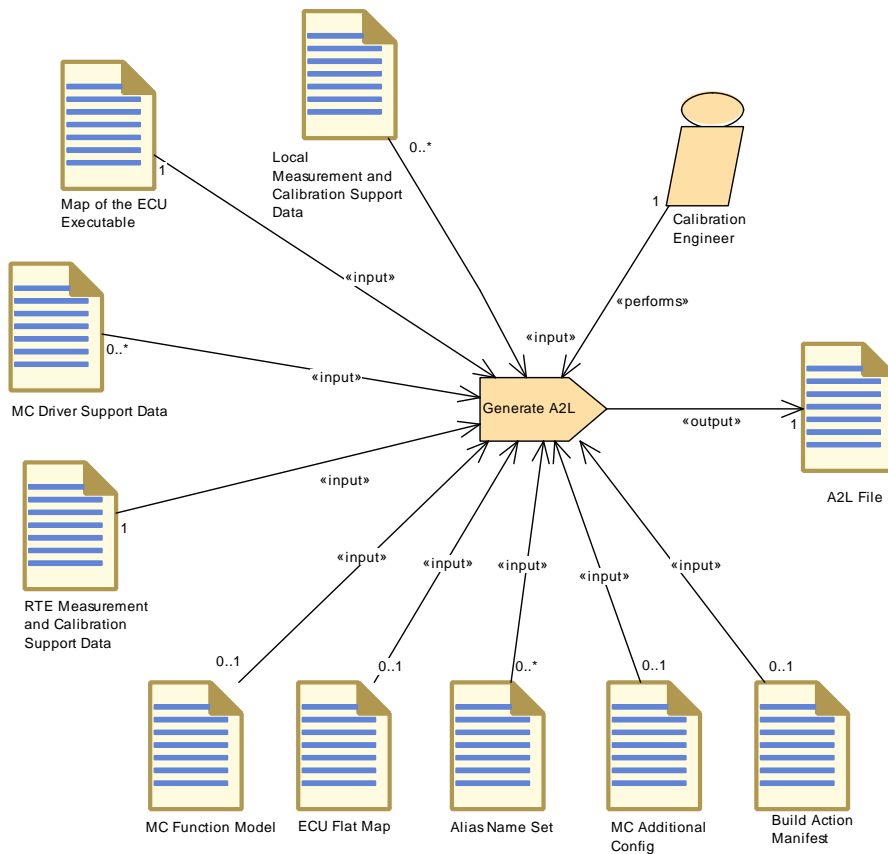
**Figure 3.127: Generate RTE Postbuild Dataset**

<b>Task Definition</b>	<b>Generate RTE Postbuild Dataset</b>		
<b>Package</b>	AUTOSAR Root::M2::Methodology::Methodology Library::Ecu::Tasks		
<b>Brief Description</b>	Postbuild Data Set Generation Phase for the RTE: It binds all variations which are for postbuild time.		
<b>Description</b>	<p>Data Set Generation Phase for the RTE: It binds all variations which are for postbuild time. The output is a data set which can be used to build an image separately from the main code.</p> <p>The supported post-build variants are defined by the PredefinedVariants referred in the post-build section of the RTE configuration. At runtime, only one of those variants can be active. This selection is done via the initialization structure for the BSW Scheduler. The actual value for this iniialization structure used for runtime initialization is defined by the configuration of the ECU State Manager.</p> <p>Meth.bindingTime = PostBuild</p>		
<b>Relation Type</b>	<b>Related Element</b>	<b>Mul.</b>	<b>Note</b>
Performed by	<a href="#">ECU Integrator</a>	1	
Consumes	<a href="#">ECU Configuration Values</a>	1	Meth.bindingTime = LinkTime
Consumes	<a href="#">ECU Extract</a>	1	Meth.bindingTime = LinkTime

Relation Type	Related Element	Mul.	Note
Consumes	Postbuild Variant Set	1	
Consumes	Predefined Variant	1	
Consumes	Build Action Manifest	0..1	The task may be controlled by a Build Action Manifest.
Consumes	Service Component Description	0..*	Meth.bindingTime = LinkTime
Produces	RTE Postbuild Variants Dataset	1	Meth.bindingTime = PostBuild
Used tool	RTE Generator	1	

**Table 3.244: Generate RTE Postbuild Dataset**

**3.6.1.28 Generate A2L**

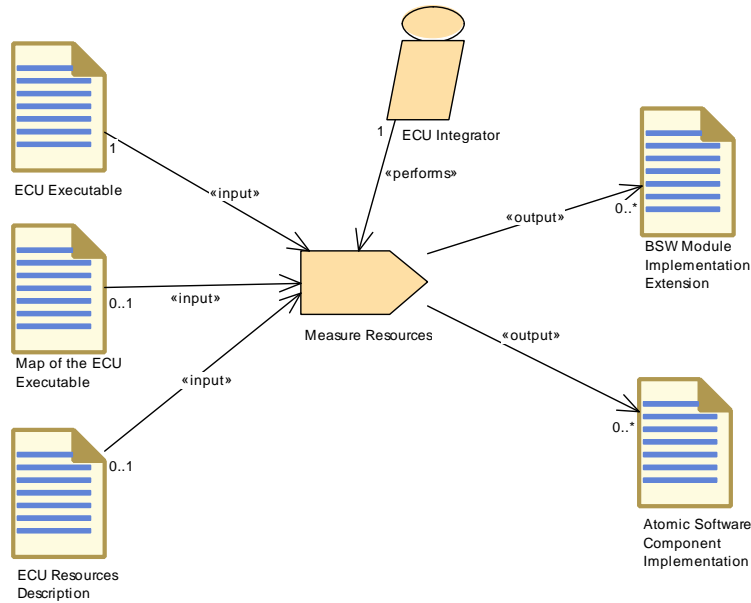


**Figure 3.128: Generate A2L**

<b>Task Definition</b>	<b>Generate A2L</b>		
<b>Package</b>	AUTOSAR Root::M2::Methodology::Methodology Library::Ecu::Tasks		
<b>Brief Description</b>	Generate the A2L File for an ECU.		
<b>Description</b>	<p>The A2L File created by this task is the final representation of the data given by RTE Measurement and Calibration Support Data and Local Measurement and Calibration Support Data.</p> <p>The main purpose of this task is to replace all symbolic information on data location found in these input data by actual addresses. Optionally, it replaces identifiers by alias names given in Alias Name Set(s). Finally is completes the A2L file with configuration from ECU driver software (MC Driver Support Data) and configuration not determined by AUTOSAR artifacts (MC Additional Configuration).</p> <p>This task is not part of AUTOSAR, it is only included for completeness of the use cases. The Map of the ECU Executable (linker map file) is shown as input in order to illustrate the principle use case only. Note that one needs additional information, like the .ELF or .COFF file, to resolve addresses of elements of composite C-variables.</p>		
<b>Relation Type</b>	<b>Related Element</b>	<b>Mul.</b>	<b>Note</b>
Performed by	Calibration Engineer	1	
Consumes	Map of the ECU Executable	1	
Consumes	RTE Measurement and Calibration Support Data	1	
Consumes	Build Action Manifest	0..1	The task may be controlled by a Build Action Manifest.
Consumes	ECU Flat Map	0..1	The ECU Flat Map is needed in case the A2L generator has to process an MC Function Model that relates to data in the ECU Flat Map.
Consumes	MC Additional Config	0..1	
Consumes	MC Function Model	0..1	This input is needed if the keyword FUNCTION shall be supported in the generated A2L.
Consumes	Alias Name Set	0..*	
Consumes	Local Measurement and Calibration Support Data	0..*	
Consumes	MC Driver Support Data	0..*	
Produces	A2L File	1	Meth.bindingTime = CodeGenerationTime

**Table 3.245: Generate A2L**

**3.6.1.29 Measure Resources**



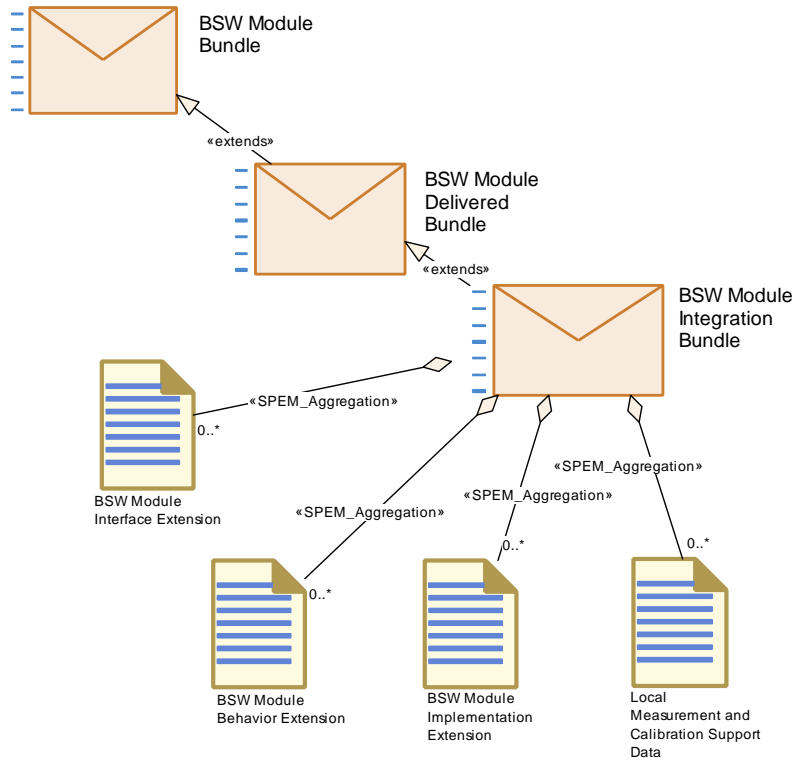
**Figure 3.129: Measure Resources**

<b>Task Definition</b>	<b>Measure Resources</b>		
<b>Package</b>	AUTOSAR Root::M2::Methodology::Methodology Library::Ecu::Tasks		
<b>Brief Description</b>	Measure the resource consumption and update the implementation section of the Application SWC and BSW Module Descriptions.		
<b>Description</b>	Measure the resource consumption and update the implementation section of the Application SWC and BSW Module Descriptions.		
<b>Relation Type</b>	<b>Related Element</b>	<b>Mul.</b>	<b>Note</b>
Performed by	<a href="#">ECU Integrator</a>	1	
Consumes	<a href="#">ECU Executable</a>	1	
Consumes	<a href="#">ECU Resources Description</a>	0..1	
Consumes	<a href="#">Map of the ECU Executable</a>	0..1	
Produces	<a href="#">Atomic Software Component Implementation</a>	0..*	Add extensions to the Implementation Description. Meth.bindingTime = PostBuild
Produces	<a href="#">BSW Module Implementation Extension</a>	0..*	Meth.bindingTime = PostBuild

**Table 3.246: Measure Resources**

### 3.6.2 Work Products

#### 3.6.2.1 BSW Module Integration Bundle



**Figure 3.130: BSW Module Integration Bundle**

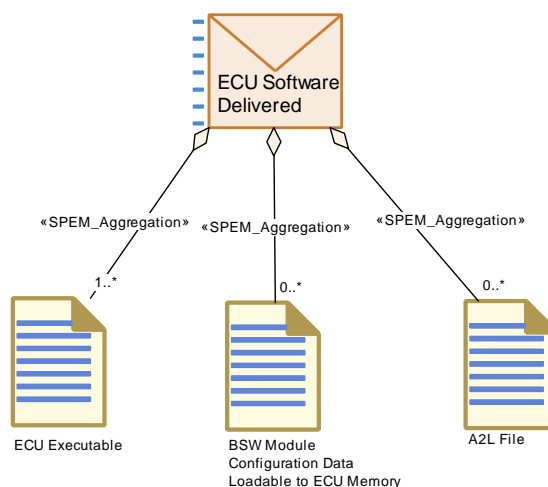
<b>Deliverable</b>	<b>BSW Module Integration Bundle</b>		
<b>Package</b>	AUTOSAR Root::M2::Methodology::Methodology Library::Ecu::Work Products		
<b>Brief Description</b>			
<b>Description</b>	Contains the BSW artifacts for one or more BSW modules completed during integration.		
<b>Kind</b>	Delivered		
<b>Extends</b>	<a href="#">BSW Module Delivered Bundle</a>		
<b>Relation Type</b>	<b>Related Element</b>	<b>Mul.</b>	<b>Note</b>
Aggregates	<a href="#">BSW Module Behavior Extension</a>	0..*	
Aggregates	<a href="#">BSW Module Implementation Extension</a>	0..*	
Aggregates	<a href="#">BSW Module Interface Extension</a>	0..*	
Aggregates	<a href="#">Local Measurement and Calibration Support Data</a>	0..*	



Relation Type	Related Element	Mul.	Note
Consumed by	Generate Scheduler	1..*	Input for BSW scheduling, BSW mode and trigger declaration, BSW exclusive areas, BSW calibration parameters that need support for software emulation.  Optionally, a Build Action Manifest maybe be used to control the generator steps. Meth.bindingTime = SystemDesignTime
Consumed by	Generate RTE	0..*	Input for BSW scheduling, BSW mode and trigger declaration, BSW exclusive areas, BSW calibration parameters that need RTE support (for software emulation).  Optionally, a Build Action Manifest maybe be used to control the generator steps. Meth.bindingTime = SystemDesignTime

**Table 3.247: BSW Module Integration Bundle**

### 3.6.2.2 ECU Software Delivered



**Figure 3.131: ECU Software Delivered**

<b>Deliverable</b>	<b>ECU Software Delivered</b>		
<b>Package</b>	AUTOSAR Root::M2::Methodology::Methodology Library::Ecu::Work Products		
<b>Brief Description</b>	All the work products that form the deliverable of an AUTOSAR ECU.		
<b>Description</b>	<p>All the work products that form the deliverable of an AUTOSAR ECU software build.</p> <p>ECU in this context means processor, so if an electronic control unit consists of several processors, one "ECU Software Delivered" will be needed for each processor.</p> <p>Note that the detailed format for all parts of this deliverable is not defined by AUTOSAR.</p>		
<b>Kind</b>	Delivered		
<b>Relation Type</b>	<b>Related Element</b>	<b>Mul.</b>	<b>Note</b>
Aggregates	<a href="#">ECU Executable</a>	1..*	
Aggregates	<a href="#">A2L File</a>	0..*	
Aggregates	<a href="#">BSW Module Configuration Data Loadable to ECU Memory</a>	0..*	
Produced by	<a href="#">Integrate Software for ECU</a>	1	

**Table 3.248: ECU Software Delivered**

### 3.6.2.3 Service Component Description

<b>Artifact</b>	<b>Service Component Description</b>		
<b>Package</b>	AUTOSAR Root::M2::Methodology::Methodology Library::Ecu::Work Products		
<b>Brief Description</b>	Describes the RTE relevant part of an AUTOSAR Service on a given ECU in form of a ServiceComponentType with all its ports and an internal behavior.		
<b>Description</b>	Describes the RTE relevant part of an AUTOSAR Service on a given ECU in form of a ServiceComponentType with all its ports and an internal behavior. This artifact must be generated during the ECU configuration process, latest before the RTE is generated. It depends on the needs of the software components for this AUTOSAR Service.		
<b>Kind</b>	AUTOSAR XML		
<b>Relation Type</b>	<b>Related Element</b>	<b>Mul.</b>	<b>Note</b>
Produced by	<a href="#">Create Service Component</a>	1	Meth.bindingTime = SystemDesignTime
Consumed by	<a href="#">Connect Service Component</a>	1	Required in order to define the connector links to the ports on the BSW side.

<i>Relation Type</i>	<i>Related Element</i>	<i>Mul.</i>	<i>Note</i>
Consumed by	<a href="#">Configure NvM</a>	0..*	The configuration of diagnostics, especially of the DEM, typically leads to the definition of additional data to be stored in NvM. One possibility to handle this is to create ServiceNeeds on the level ServiceComponentType which is then taken into account for the configuration of the NvM.
Consumed by	<a href="#">Configure RTE</a>	0..*	The Internal Behavior of Service Components contributes to the RTE configuration.
Consumed by	<a href="#">Generate RTE</a>	0..*	Meth.bindingTime = SystemDesignTime
Consumed by	<a href="#">Generate RTE Postbuild Dataset</a>	0..*	Meth.bindingTime = LinkTime
Consumed by	<a href="#">Generate RTE Prebuild Dataset</a>	0..*	Meth.bindingTime = CodeGenerationTime
Use meta model element	ServiceSwComponentType	1	
Use meta model element	SwcInternalBehavior	1	

**Table 3.249: Service Component Description**

### 3.6.2.4 ECU Service Connectors

<i>Artifact</i>	<b>ECU Service Connectors</b>		
<i>Package</i>	AUTOSAR Root::M2::Methodology::Methodology Library::Ecu::Work Products		
<i>Brief Description</i>	The connectors to the Service Components which complete the complete Software Composition predefined in the ECU extract.		
<i>Description</i>	The assembly connectors to the Service Components which complete the Software Composition predefined in the ECU extract. These connectors are added during ECU integration as a separate artifact to the already defined composition of Atomic Software Components.		
<i>Kind</i>	AUTOSAR XML		
<i>Relation Type</i>	<i>Related Element</i>	<i>Mul.</i>	<i>Note</i>
Produced by	<a href="#">Connect Service Component</a>	1..*	Meth.bindingTime = SystemDesignTime
Consumed by	<a href="#">Define ECU Timing</a>	1..*	
Consumed by	<a href="#">Generate RTE</a>	0..*	Meth.bindingTime = SystemDesignTime
Use meta model element	AssemblySwConnector	1	

**Table 3.250: ECU Service Connectors**

### 3.6.2.5 ECU Timing

<b>Artifact</b>	<b>ECU Timing</b>		
<b>Package</b>	AUTOSAR Root::M2::Methodology::Methodology Library::Ecu::Work Products		
<b>Brief Description</b>	TimingDescription and TimingConstraints for a concrete ECU		
<b>Description</b>	TimingDescription and TimingConstraints defined for a concrete ECU taking the ECU configuration and the ECU Software Composition (including their implementation) into account.		
<b>Kind</b>	AUTOSAR XML		
<b>Relation Type</b>	<b>Related Element</b>	<b>Mul.</b>	<b>Note</b>
Produced by	<a href="#">Define ECU Timing</a>	1	Meth.bindingTime = SystemDesignTime
Consumed by	<a href="#">Configure OS</a>	0..1	
Consumed by	<a href="#">Configure RTE</a>	0..1	
Consumed by	<a href="#">Configure Watchdog Manager</a>	0..1	
Consumed by	<a href="#">Create Service Component</a>	0..1	Additional information for fine tuning configuration decisions.
Use meta model element	EcuTiming	1	

**Table 3.251: ECU Timing**

### 3.6.2.6 BSW Module Interface Extension

<b>Artifact</b>	<b>BSW Module Interface Extension</b>		
<b>Package</b>	AUTOSAR Root::M2::Methodology::Methodology Library::Ecu::Work Products		
<b>Brief Description</b>			
<b>Description</b>	Additions to the BSW Module on the interface level during integration. It is used for example to add Basic Software Module Entries in response to the ECU configuration, for example callback declarations.		
<b>Kind</b>	AUTOSAR XML		
<b>Relation Type</b>	<b>Related Element</b>	<b>Mul.</b>	<b>Note</b>
Aggregated by	<a href="#">BSW Module Integration Bundle</a>	0..*	
Produced by	<a href="#">Generate BSW Configuration Code</a>	0..1	
Use meta model element	BswModuleDescription	1	
Use meta model element	BswModuleEntry	1	

**Table 3.252: BSW Module Interface Extension**

### 3.6.2.7 BSW Module Behavior Extension

<b>Artifact</b>	<b>BSW Module Behavior Extension</b>		
<b>Package</b>	AUTOSAR Root::M2::Methodology::Methodology Library::Ecu::Work Products		
<b>Brief Description</b>			
<b>Description</b>	Additions to the BSW Module on the behavior level during integration. It can for example be used to add local data declaration (constantMemory, staticMemory, perInstanceMemory) for debug or calibration purposes in response to configuration parameters.		
<b>Kind</b>	AUTOSAR XML		
<b>Relation Type</b>	<b>Related Element</b>	<b>Mul.</b>	<b>Note</b>
Aggregated by	<a href="#">BSW Module Integration Bundle</a>	0..*	
Produced by	<a href="#">Generate BSW Configuration Code</a>	0..1	
Consumed by	<a href="#">Generate Local MC Data Support</a>	0..1	Meth.bindingTime = SystemDesignTime
Use meta model element	BswInternalBehavior	1	

**Table 3.253: BSW Module Behavior Extension**

### 3.6.2.8 BSW Module Implementation Extension

<b>Artifact</b>	<b>BSW Module Implementation Extension</b>		
<b>Package</b>	AUTOSAR Root::M2::Methodology::Methodology Library::Ecu::Work Products		
<b>Brief Description</b>			
<b>Description</b>	Additions to the BSW Module on the implementation level during integration. It is used for example to add information on resource consumption.		
<b>Kind</b>	AUTOSAR XML		
<b>Relation Type</b>	<b>Related Element</b>	<b>Mul.</b>	<b>Note</b>
Aggregated by	<a href="#">BSW Module Integration Bundle</a>	0..*	
Produced by	<a href="#">Generate BSW Configuration Code</a>	0..1	
Produced by	<a href="#">Measure Resources</a>	0..*	Meth.bindingTime = PostBuild
Use meta model element	BswImplementation	1	

**Table 3.254: BSW Module Implementation Extension**

### 3.6.2.9 ECU Configuration Values

<b>Artifact</b>	<b>ECU Configuration Values</b>		
<b>Package</b>	AUTOSAR Root::M2::Methodology::Methodology Library::Ecu::Work Products		
<b>Brief Description</b>	The collection of all configuration values for an ECU.		
<b>Description</b>	<p>First of all, the ECU Configuration Values contain a link to the System element which comes with the ECU Extract thus it can be used as a root element for integration on this ECU.</p> <p>Furtheron, it contains a collection of all configuration values for an ECU, which is gradually filled. Starting with the root element EcucValueCollection it contains the actual configuration settings EcucModuleConfigurationValues for each module including the RTE. Note that due to their strong interrelation, these parts are not considered as separate artifacts in the use cases for ECU integration.</p> <p>A special set of configuration values is the so-called EcuC-configuration: It contains the configuration values which are relevant for the whole ECU. Tools that interpret the configuration values need to know the underlying parameter definition. Therefore, in addition to the configuration values, each EcucValueCollection contains a link and the version of the parameter definition to which it adheres. This parameter definition is either part of the AUTOSAR Standardized ECU Configuration Parameter Definition or, in case of vendor specific extensions, is given by the artifact Basic Software Module Vendor-Specific Configuration Parameter Definition.</p>		
<b>Kind</b>	AUTOSAR XML		
<b>Relation Type</b>	<b>Related Element</b>	<b>Mul.</b>	<b>Note</b>
Produced by	<a href="#">Configure Memmap Allocation</a>	1	MemMapAllocation: Meth.bindingTime = SystemDesignTime
Produced by	<a href="#">Create Service Component</a>	1	Enter links to the created SwComponentPrototypes. Meth.bindingTime = SystemDesignTime
Produced by	<a href="#">Generate Base Ecu Configuration</a>	1	Meth.bindingTime = SystemDesignTime
Produced by	<a href="#">Prepare ECU Configuration</a>	1	
Produced by	<a href="#">Generate RTE</a>	0..1	Optional output for the configuration of the OS. Meth.bindingTime = CodeGenerationTime
In/out	<a href="#">Configure BSW and RTE</a>	1	
In/out	<a href="#">Configure Com</a>	1	
In/out	<a href="#">Configure Debug</a>	1	
In/out	<a href="#">Configure Diagnostics</a>	1	Configuration Values for DEM, DCM, DLT, FIM.
In/out	<a href="#">Configure ECUC</a>	1	
In/out	<a href="#">Configure IO Hardware abstraction</a>	1	
In/out	<a href="#">Configure MCAL</a>	1	

<b>Relation Type</b>	<b>Related Element</b>	<b>Mul.</b>	<b>Note</b>
In/out	Configure Mode Management	1	
In/out	Configure NvM	1	
In/out	Configure OS	1	
In/out	Configure RTE	1	
In/out	Configure Watch-dog Manager	1	
Consumed by	Define ECU Timing	1	
Consumed by	Generate BSW Configuration Code	1	
Consumed by	Generate BSW Configuration Data Loadable	1	
Consumed by	Generate BSW Memory Mapping Header	1	MemMapAllocation: Mapping of the abstract sections (SwAddressMethods for generic mapping resp. MemorySection Elements for specific mapping) to the compiler specific MemMapAddressingModes. Meth.bindingTime = SystemDesignTime
Consumed by	Generate BSW Postbuild Configuration Code	1	
Consumed by	Generate BSW Precompile Configuration Header	1	
Consumed by	Generate BSW Source Code	1	
Consumed by	Generate BSW and RTE	1	
Consumed by	Generate OS	1	Meth.bindingTime = SystemDesignTime
Consumed by	Generate RTE	1	Meth.bindingTime = SystemDesignTime
Consumed by	Generate RTE Postbuild Dataset	1	Meth.bindingTime = LinkTime
Consumed by	Generate RTE Prebuild Dataset	1	find the Predefined Variant to be used Meth.bindingTime = CodeGenerationTime
Consumed by	Generate SWC Memory Mapping Header	1	MemMapAllocation: Mapping of the abstract sections (SwAddressMethods for generic mapping resp. MemorySection Elements for specific mapping) to the compiler specific MemMapAddressingModes. Meth.bindingTime = SystemDesignTime
Consumed by	Generate Scheduler	1	Configuration values for the BSW Scheduler (subset of RTE configuration).  Meth.bindingTime = SystemDesignTime

<b>Relation Type</b>	<b>Related Element</b>	<b>Mul.</b>	<b>Note</b>
Consumed by	Create Service Component	0..1	The creation of Service Component details may depend on ECU configuration values, especially for the DCM.
Consumed by	Generate BSW Memory Mapping Header	0..1	moduleDescription: List of used BSW modules (EcucValueCollection.ecucValue.moduleDescription) Meth.bindingTime = SystemDesignTime
Consumed by	Generate Compiler Configuration	0..1	RtelImplementationRef: Existence of SWCs could be identified by usage of the RTE ECU Configuration "RteSwComponentType.RtelImplementationRef" Meth.bindingTime = SystemDesignTime
Consumed by	Generate Compiler Configuration	0..1	ModuleDescription: List of used BSW modules (EcucValueCollection.ecucValue.moduleDescription) Meth.bindingTime = SystemDesignTime
Consumed by	Generate ECU Executable	0..1	may be used to set up build environment Meth.bindingTime = CompileTime
Consumed by	Generate SWC Memory Mapping Header	0..1	RtelImplementationRef: Existence of SWCs could be identified by usage of the RTE ECU Configuration "RteSwComponentType.RtelImplementationRef" Meth.bindingTime = SystemDesignTime
Use meta model element	EcucModuleConfigurationValues	1	
Use meta model element	EcucValueCollection	1	

**Table 3.255: ECU Configuration Values**

### 3.6.2.10 RTE Implementation Description

<b>Artifact</b>	<b>RTE Implementation Description</b>		
<b>Package</b>	AUTOSAR Root::M2::Methodology::Methodology Library::Ecu::Work Products		
<b>Brief Description</b>	Implementation Description for the RTE, generated by the RTE generator.		
<b>Description</b>	Implementation Description for the RTE, generated by the RTE generator. Uses the format of BswImplementation. This artifact is required to provide information for other generators and the build process, namely debugging information, memory section. It aggregates also the support data for measurement and calibration, which is considered as a separate artifact.		
<b>Kind</b>	AUTOSAR XML		
<b>Relation Type</b>	<b>Related Element</b>	<b>Mul.</b>	<b>Note</b>
Produced by	Generate RTE	1	Meth.bindingTime = CodeGenerationTime



<i>Relation Type</i>	<i>Related Element</i>	<i>Mul.</i>	<i>Note</i>
Produced by	<a href="#">Generate Scheduler</a>	0..1	Creates a subset of the RTE implementation description that contains only the description of data owned by the BSW Scheduler. Meth.bindingTime = CodeGenerationTime
Use meta model element	BswImplementation	1	

**Table 3.256: RTE Implementation Description**

### 3.6.2.11 RTE Prebuild Configuration Header

<i>Artifact</i>	<b>RTE Prebuild Configuration Header</b>		
<i>Package</i>	AUTOSAR Root::M2::Methodology::Methodology Library::Ecu::Work Products		
<i>Brief Description</i>	RTE Prebuild Configuration Header File. It defines all variants for the RTE code which have to be bound later than code generation time but before build time.		
<i>Description</i>	RTE Prebuild Configuration Header File. It defines the setting of all variants for the RTE code (via macro code) which have to be bound later than code generation time but before build time.		
<i>Kind</i>	Bound Source Code		
<i>Relation Type</i>	<i>Related Element</i>	<i>Mul.</i>	<i>Note</i>
Produced by	<a href="#">Generate RTE Prebuild Dataset</a>	1	Meth.bindingTime = PreCompileTime
Consumed by	<a href="#">Compile ECU Source Code</a>	0..1	Meth.bindingTime = PreCompileTime

**Table 3.257: RTE Prebuild Configuration Header**

### 3.6.2.12 Calibration Parameter Value Set

<b>Artifact</b>	<b>Calibration Parameter Value Set</b>		
<b>Package</b>	AUTOSAR Root::M2::Methodology::Methodology Library::Ecu::Work Products		
<b>Brief Description</b>	Calibration Parameter Value Setting		
<b>Description</b>	<p>A set of calibration parameter values used to initialize the memory objects which implement calibration parameters. The values are specific for the software component instances in ECU scope. They will override any initial values defined for those parameters within the ECU Extract. The parameter values can be defined as <code>ApplicationDataTypes</code> or as <code>ImplementationDataTypes</code> which has several use cases. These two use cases are supported by the RTE generation phase:</p> <ul style="list-style-type: none"> <li>Parameter values defined as <code>ImplementationDataTypes</code> can be used as instance specific initialization for calibration parameters within components as soon as the respective <code>ImplementationDataTypes</code> are available (which must be the case for RTE generation anyhow).</li> <li>Parameter values defined as <code>ApplicationDataTypes</code> can be used as instance specific initialization for calibration parameters which are only defined with <code>ApplicationDataTypes</code>.</li> </ul> <p>The next case is not modelled within AUTOSAR in detail:</p> <ul style="list-style-type: none"> <li>Parameter values defined as <code>ApplicationDataTypes</code> can be used to exchange initial values with the component vendor not publishing the transformation algorithm between <code>ApplicationDataTypes</code> and <code>ImplementationDataTypes</code></li> </ul>		
<b>Kind</b>	AUTOSAR XML		
<b>Relation Type</b>	<b>Related Element</b>	<b>Mul.</b>	<b>Note</b>
Produced by	<a href="#">Provide RTE Calibration Dataset</a>	1	
Consumed by	<a href="#">Generate RTE</a>	0..1	Meth.bindingTime = SystemDesignTime
Use meta model element	CalibrationParameterValueSet	1	

**Table 3.258: Calibration Parameter Value Set**

### 3.6.2.13 MC Function Model

<b>Artifact</b>	<b>MC Function Model</b>		
<b>Package</b>	AUTOSAR Root::M2::Methodology::Methodology Library::Ecu::Work Products		
<b>Brief Description</b>	A functional model to be used for A2L generation.		
<b>Description</b>	<p>As set of nested McFunction elements to be used as input to generate A2L. Its purpose is to</p> <ul style="list-style-type: none"> <li>• assign calibration parameters to a logical function</li> <li>• assign measurement variables to a logical function</li> <li>• structure functions hierarchically</li> </ul> <p>It shall support the generation of the FUNCTION keyword and related elements defined in ASAM MCD-2 MC.</p> <p>An MC Function Model refers to the data descriptions in other AUTOSAR XML artifacts either via entries in the ECU Flat Map or via McDataInstances being part of Measurement and Calibration Support Data.</p>		
<b>Kind</b>	AUTOSAR XML		
<b>Relation Type</b>	<b>Related Element</b>	<b>Mul.</b>	<b>Note</b>
Produced by	<a href="#">Create MC Function Model</a>	1	
Consumed by	<a href="#">Generate A2L</a>	0..1	This input is needed if the keyword FUNCTION shall be supported in the generated A2L.
Use meta model element	McFunction	1	

**Table 3.259: MC Function Model**

### 3.6.2.14 Local Measurement and Calibration Support Data

<b>Artifact</b>	<b>Local Measurement and Calibration Support Data</b>		
<b>Package</b>	AUTOSAR Root::M2::Methodology::Methodology Library::Ecu::Work Products		
<b>Brief Description</b>	Generated artifact, which supports the later generation of "A2L"-files for measurement and calibration data which are owned locally by a component or module.		
<b>Description</b>	<p>Generated artifact which is used as an input for the later generation of "A2L"-files for measurement and calibration. It relates the measurement and calibration data listed in the ECU FlatMap to the C-variables used locally within a component or module (this is relevant only valid for those parameters and variables, which are not implemented by the RTE) . In addition, it contains all configuration data which are relevant for the A2L generator (e.g. the access method to calibration data within a Complex Driver).</p> <p>This XML-artifact is linked via a (splittable) aggregation to the Implementation Description of the component or module, but it is considered as a separate artifact.</p>		
<b>Kind</b>	AUTOSAR XML		
<b>Relation Type</b>	<b>Related Element</b>	<b>Mul.</b>	<b>Note</b>
Aggregated by	<a href="#">BSW Module Integration Bundle</a>	0..*	
Produced by	<a href="#">Generate Local M C Data Support</a>	1	Meth.bindingTime = CodeGenerationTime
Consumed by	<a href="#">Create MC Function Model</a>	0..*	Used if the MC Function Model shall refer to McDataInstances allocated by BSW modules without RTE support.
Consumed by	<a href="#">Generate A2L</a>	0..*	
Use meta model element	McSupportData	1	

**Table 3.260: Local Measurement and Calibration Support Data**

### 3.6.2.15 RTE Measurement and Calibration Support Data

<b>Artifact</b>	<b>RTE Measurement and Calibration Support Data</b>		
<b>Package</b>	AUTOSAR Root::M2::Methodology::Methodology Library::Ecu::Work Products		
<b>Brief Description</b>	RTE generator output, which supports the later generation of "A2L"-files for the measurement and calibration data which are owned by the RTE.		
<b>Description</b>	<p>RTE generator output, which is used as an input for the later generation of "A2L"-files for measurement and calibration. It relates the measurement and calibration data listed in the ECU FlatMap to the C-variables of the generated RTE code. For all these data it contains copies of the attributes which are relevant for A2L generation. In additions it contains all configuration data which are relevant for the A2L generator (namely the access method to calibration data which is supported by the RTE). This XML-artifact is linked via a (splitable) aggregation to the RTE Implementation Description, but is considered as a separate artifact.</p> <p>The most important attributes for each data instance are:</p> <ul style="list-style-type: none"> <li>• Its shortName copied from the ECU Flat Map to be used as identifier and for display by the MC system.</li> <li>• The category copied from the corresponding data type (ApplicationDataType if defined, otherwise ImplementationDataType) as far as applicable.</li> <li>• The symbol used in the programming language. It will be used to find out the actual memory address by the final generation tool with the help of linker generated information.</li> <li>• All aggregated and referred elements like CompuMethod or BaseType describing the data (with the exception of the Flat Map) are completely copied from "upstream" information. Therefore this artifact is a self-contained description which can be forwarded to the A2L generator without needing related descriptions.</li> </ul>		
<b>Kind</b>	AUTOSAR XML		
<b>Relation Type</b>	<b>Related Element</b>	<b>Mul.</b>	<b>Note</b>
Produced by	<a href="#">Generate RTE</a>	0..1	Meth.bindingTime = CodeGenerationTime
Produced by	<a href="#">Generate Scheduler</a>	0..1	Creates a subset of the measurement & calibration support data related only to the data owned by the BSW Scheduler. Meth.bindingTime = CodeGenerationTime
Consumed by	<a href="#">Generate A2L</a>	1	
Consumed by	<a href="#">Create MC Function Model</a>	0..1	Used if the MC Function Model shall refer to McDataInstances allocated by the RTE.
Use meta model element	McSupportData	1	

**Table 3.261: RTE Measurement and Calibration Support Data**

### 3.6.2.16 RTE Source Code

<b>Artifact</b>	<b>RTE Source Code</b>		
<b>Package</b>	AUTOSAR Root::M2::Methodology::Methodology Library::Ecu::Work Products		
<b>Brief Description</b>	Source code implementing the RTE on a CPU.		
<b>Description</b>	<p>Source code implementing the RTE on a CPU.</p> <p>The output of an RTE generator can consist of both generated code and configuration for library code that may be supplied as either object code or source code. Both configured and generated code reference standard definitions that are defined in one of two standardized header files: The RTE Header File and the Lifecycle Header File. These header files are not explicitly shown in the methodology, as in all tasks they appear with the RTE source code. For details refer to AUTOSAR_SWS_RTE.pdf.</p> <p>Apart from this, the file structure is not standardized, and therefore represented as one single artifact in the methodology. In general, the RTE code can be partitioned in several files. The partitioning depends on the RTE vendor's software design and generation strategy. Nevertheless it shall be possible to clearly identify code and header files which are part of the RTE module.</p>		
<b>Kind</b>	Source Code		
<b>Relation Type</b>	<b>Related Element</b>	<b>Mul.</b>	<b>Note</b>
Produced by	Generate BSW and RTE	1	
Produced by	Generate RTE	1	Meth.bindingTime = CodeGenerationTime
Consumed by	Compile ECU Source Code	1	Meth.bindingTime = CodeGenerationTime

**Table 3.262: RTE Source Code**

### 3.6.2.17 BSW Scheduler Code

<b>Artifact</b>	<b>BSW Scheduler Code</b>		
<b>Package</b>	AUTOSAR Root::M2::Methodology::Methodology Library::Ecu::Work Products		
<b>Brief Description</b>	Generated Code implementing the BSW Scheduler.		
<b>Description</b>	Generated Code implementing the BSW Scheduler. It can be source or macro code.		
<b>Kind</b>	Source Code		
<b>Relation Type</b>	<b>Related Element</b>	<b>Mul.</b>	<b>Note</b>
Produced by	Generate RTE	1	Meth.bindingTime = CodeGenerationTime
Produced by	Generate Scheduler	1	Meth.bindingTime = CodeGenerationTime
Consumed by	Compile ECU Source Code	1	Meth.bindingTime = CodeGenerationTime

<i>Relation Type</i>	<i>Related Element</i>	<i>Mul.</i>	<i>Note</i>
----------------------	------------------------	-------------	-------------

**Table 3.263: BSW Scheduler Code**

### 3.6.2.18 OS Generated Code

<i>Artifact</i>	<b>OS Generated Code</b>		
<b>Package</b>	AUTOSAR Root::M2::Methodology::Methodology Library::Ecu::Work Products		
<b>Brief Description</b>	OS configuration generated code		
<b>Description</b>	OS configuration generated code. OS configuration code are composed of header and C files. These will be compiled with the source code in the build process (see Compile Source Code).		
<b>Kind</b>	Source Code		
<i>Relation Type</i>	<i>Related Element</i>	<i>Mul.</i>	<i>Note</i>
Produced by	Generate OS	1	Meth.bindingTime = CodeGenerationTime
Consumed by	Compile ECU Source Code	1	Meth.bindingTime = CodeGenerationTime

**Table 3.264: OS Generated Code**

### 3.6.2.19 RTE Postbuild Variants Dataset

<i>Artifact</i>	<b>RTE Postbuild Variants Dataset</b>		
<b>Package</b>	AUTOSAR Root::M2::Methodology::Methodology Library::Ecu::Work Products		
<b>Brief Description</b>	Generated code used to resolve postbuild variants in the RTE.		
<b>Description</b>	<p>Generated code used to resolve postbuild variants in the RTE. It consists of a c-file and a header file:</p> <ul style="list-style-type: none"> <li>The RTE generator must generate a Rte_PBCfg.c file containing the declarations and initializations of one or more RTE post build variants. Only one of these variants can be active at runtime.</li> <li>The RTE generator shall generate in the Rte_PBCfg.h file the SchM_ConfigType type declaration of the predefined post build variants data structure. This header file must be used by other RTE modules to resolve their runtime variabilities.</li> </ul>		
<b>Kind</b>	Bound Source Code		
<i>Relation Type</i>	<i>Related Element</i>	<i>Mul.</i>	<i>Note</i>
Produced by	Generate RTE Postbuild Dataset	1	Meth.bindingTime = PostBuild

**Table 3.265: RTE Postbuild Variants Dataset**

### 3.6.2.20 ECU Object Code

<b>Artifact</b>	<b>ECU Object Code</b>		
<b>Package</b>	AUTOSAR Root::M2::Methodology::Methodology Library::Ecu::Work Products		
<b>Brief Description</b>			
<b>Description</b>	Object code file produced by compilation during ECU integration.  To be distinguished from code files which are already delivered as object code for integration (see Basic Software Module Object Code or Atomic Software Component Object Code).		
<b>Kind</b>	Object Code		
<b>Relation Type</b>	<b>Related Element</b>	<b>Mul.</b>	<b>Note</b>
Produced by	<a href="#">Compile ECU Source Code</a>	1..*	Meth.bindingTime = CompileTime
Consumed by	<a href="#">Generate ECU Executable</a>	1..*	from generated or delivered source code Meth.bindingTime = CompileTime
Consumed by	<a href="#">Link ECU Code during Link Time Configuration</a>	1..*	

**Table 3.266: ECU Object Code**

### 3.6.2.21 ECU Executable

<b>Artifact</b>	<b>ECU Executable</b>		
<b>Package</b>	AUTOSAR Root::M2::Methodology::Methodology Library::Ecu::Work Products		
<b>Brief Description</b>	The executable image containing all the fully integrated software ready to download to an ECU.		
<b>Description</b>	The executable image containing all the fully integrated software ready to download to an ECU. This work product and its format is not defined by AUTOSAR, it is only included for completeness of the use cases.		
<b>Kind</b>	Executable		
<b>Relation Type</b>	<b>Related Element</b>	<b>Mul.</b>	<b>Note</b>
Aggregated by	<a href="#">ECU Software Delivered</a>	1..*	
Produced by	<a href="#">Generate ECU Executable</a>	1	Meth.bindingTime = LinkTime
Produced by	<a href="#">Link ECU Code after Precompile Configuration</a>	1	
Produced by	<a href="#">Link ECU Code during Link Time Configuration</a>	1	
Produced by	<a href="#">Link ECU Code during Post-build Time Selectable</a>	1	
Consumed by	<a href="#">Measure Resources</a>	1	

**Table 3.267: ECU Executable**



### 3.6.2.22 Map of the ECU Executable

<b>Artifact</b>	<b>Map of the ECU Executable</b>		
<b>Package</b>	AUTOSAR Root::M2::Methodology::Methodology Library::Ecu::Work Products		
<b>Brief Description</b>	Linker map file of the executable.		
<b>Description</b>	Linker map file of the executable. This work product and its format is not defined by AUTOSAR, it is only included for completeness of the use cases.		
<b>Kind</b>	Text		
<b>Relation Type</b>	<b>Related Element</b>	<b>Mul.</b>	<b>Note</b>
Produced by	<a href="#">Generate ECU Executable</a>	1	Meth.bindingTime = LinkTime
Consumed by	<a href="#">Generate A2L</a>	1	
Consumed by	<a href="#">Measure Resources</a>	0..1	

**Table 3.268: Map of the ECU Executable**

### 3.6.2.23 A2L File

<b>Artifact</b>	<b>A2L File</b>		
<b>Package</b>	AUTOSAR Root::M2::Methodology::Methodology Library::Ecu::Work Products		
<b>Brief Description</b>	Input file for measurement and calibration tools.		
<b>Description</b>	Input file for measurement and calibration tools related to one ECU. This format is not in the scope of AUTOSAR, it is defined by the ASAM organization. The work product is only included for completeness of the use cases.		
<b>Kind</b>	Text		
<b>Relation Type</b>	<b>Related Element</b>	<b>Mul.</b>	<b>Note</b>
Aggregated by	<a href="#">ECU Software Delivered</a>	0..*	
Produced by	<a href="#">Generate A2L</a>	1	Meth.bindingTime = CodeGenerationTime

**Table 3.269: A2L File**

### 3.6.2.24 MC Driver Support Data

<b>Artifact</b>	<b>MC Driver Support Data</b>		
<b>Package</b>	AUTOSAR Root::M2::Methodology::Methodology Library::Ecu::Work Products		
<b>Brief Description</b>	Support data describing the specific access of a driver (e.g. XCP) for exchange of data for measurement and calibration.		
<b>Description</b>	<p>Support data describing the specific access method of a driver (e.g. XCP) in order to exchange data for measurement and calibration. These are the so-called IF-DATA needed in the A2L files.</p> <p>This artifact shall be generated by a driver( e.g. XCP) specific generator out of its ECU configuration. This format is not defined by AUTOSAR. The work product is only included for completeness of the use cases.</p>		
<b>Kind</b>	Custom		
<b>Relation Type</b>	<b>Related Element</b>	<b>Mul.</b>	<b>Note</b>
Consumed by	<a href="#">Generate A2L</a>	0..*	

**Table 3.270: MC Driver Support Data**

### 3.6.2.25 MC Additional Config

<b>Artifact</b>	<b>MC Additional Config</b>		
<b>Package</b>	AUTOSAR Root::M2::Methodology::Methodology Library::Ecu::Work Products		
<b>Brief Description</b>	External configuration data needed to generate the A2L file.		
<b>Description</b>	Additional configuration data needed to generate the A2L file. This format is not defined by AUTOSAR. The work product is only included for completeness of the use cases.		
<b>Kind</b>	Custom		
<b>Relation Type</b>	<b>Related Element</b>	<b>Mul.</b>	<b>Note</b>
Consumed by	<a href="#">Generate A2L</a>	0..1	

**Table 3.271: MC Additional Config**

## 3.6.3 Tools

### 3.6.3.1 RTE Generator

<b>Tool</b>	<b>RTE Generator</b>		
<b>Package</b>	AUTOSAR Root::M2::Methodology::Methodology Library::Ecu::Guidance		
<b>Brief Description</b>			
<b>Description</b>	RTE Generator used for several tasks during ECU integration.		
<b>Kind</b>			
<b>Relation Type</b>	<b>Related Element</b>	<b>Mul.</b>	<b>Note</b>
Used	<a href="#">Generate RTE</a>	1	
Used	<a href="#">Generate RTE Postbuild Dataset</a>	1	

Relation Type	Related Element	Mul.	Note
Used	Generate RTE Prebuild Dataset	1	
Used	Generate Scheduler	1	

Table 3.272: RTE Generator

### 3.6.3.2 BSW Generator Framework

Tool	BSW Generator Framework		
Package	AUTOSAR Root::M2::Methodology::Methodology Library::Ecu::Guidance		
Brief Description			
Description	Framework that uses BSW generators that are being delivered as part of individual modules.		
Kind			
Relation Type	Related Element	Mul.	Note
Used	Generate BSW Configuration Code	1	

Table 3.273: BSW Generator Framework

## 3.6.4 ECU Config Classes

### 3.6.4.1 Tasks

#### 3.6.4.1.1 Compile Unconfigured Bsw

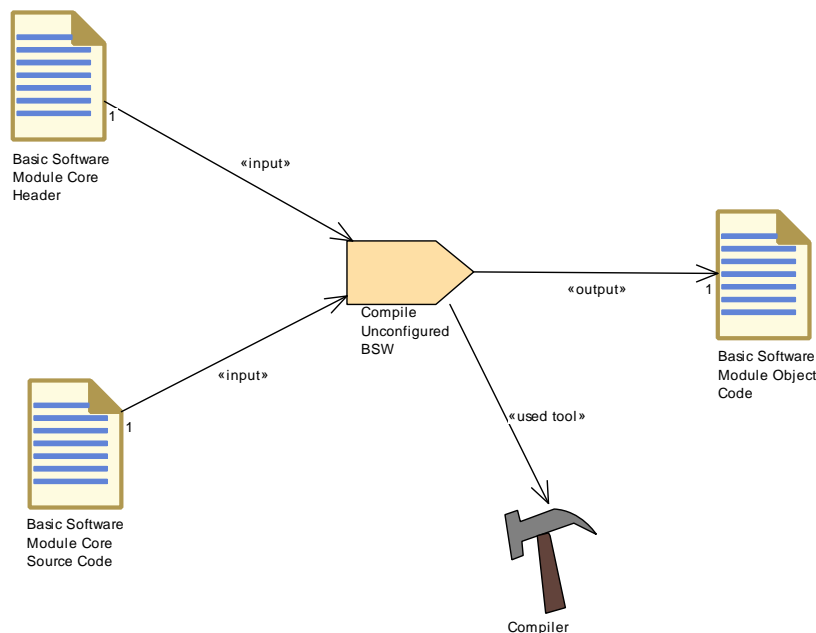
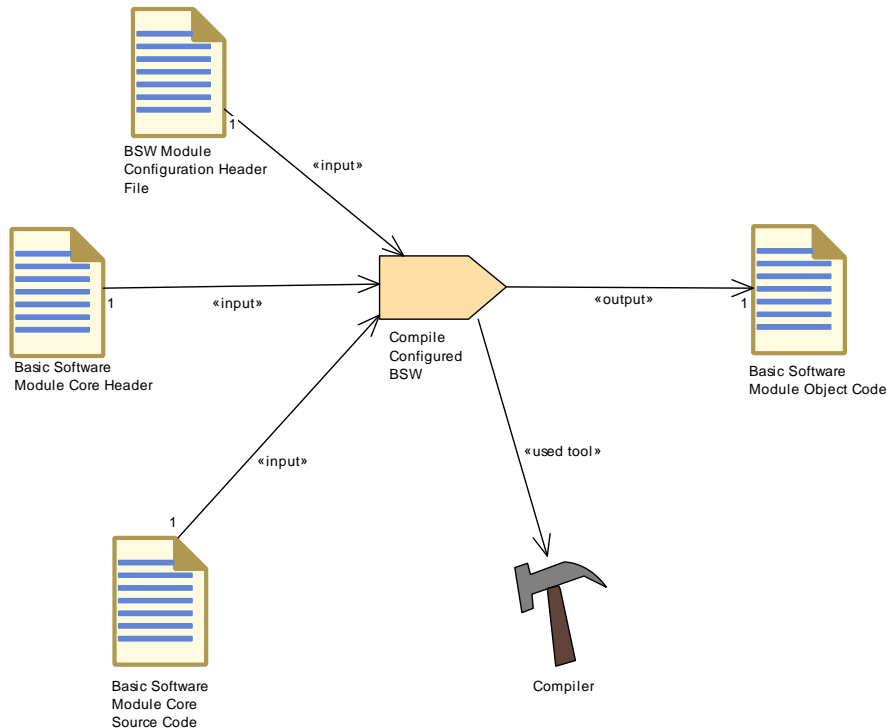


Figure 3.132: Compile Unconfigured Bsw

<b>Task Definition</b>	<b>Compile Unconfigured BSW</b>		
<b>Package</b>	AUTOSAR Root::M2::Methodology::Methodology Library::Ecu::ECU Config Classes::Tasks		
<b>Brief Description</b>	Compile unconfigured BSW to get a BSW Module Object Code.		
<b>Description</b>	Compile Unconfigured BSW is the usual step to compile files without any configuration data when no configuration is needed. This can be use either in the pre-compile, link or post-build time.		
<b>Relation Type</b>	<b>Related Element</b>	<b>Mul.</b>	<b>Note</b>
Consumes	Basic Software Module Core Header	1	
Consumes	Basic Software Module Core Source Code	1	
Produces	Basic Software Module Object Code	1	
Used tool	Compiler	1	

**Table 3.274: Compile Unconfigured BSW**

### 3.6.4.1.2 Compile Configured Bsw

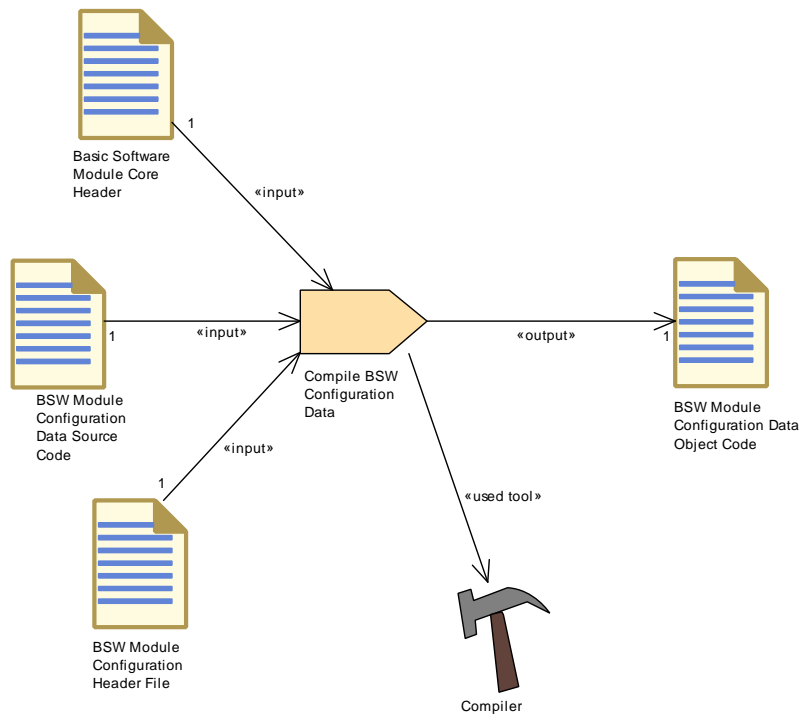


**Figure 3.133: Compile Configured Bsw**

<b>Task Definition</b>	<b>Compile Configured BSW</b>		
<b>Package</b>	AUTOSAR Root::M2::Methodology::Methodology Library::Ecu::ECU Config Classes::Tasks		
<b>Brief Description</b>	Compile Configured BSW to get a BSW Module Object Code		
<b>Description</b>	Compile Configured BSW to get a Basic Software Module Object Code used in the link steps. This Configured BSW is representing C files that have already included all needed configured data. This is done in the pre-compile time.		
<b>Relation Type</b>	<b>Related Element</b>	<b>Mul.</b>	<b>Note</b>
Consumes	BSW Module Configuration Header File	1	
Consumes	Basic Software Module Core Header	1	
Consumes	Basic Software Module Core Source Code	1	
Produces	Basic Software Module Object Code	1	
Used tool	Compiler	1	

**Table 3.275: Compile Configured BSW**

### 3.6.4.1.3 Compile BSW Configuration Data

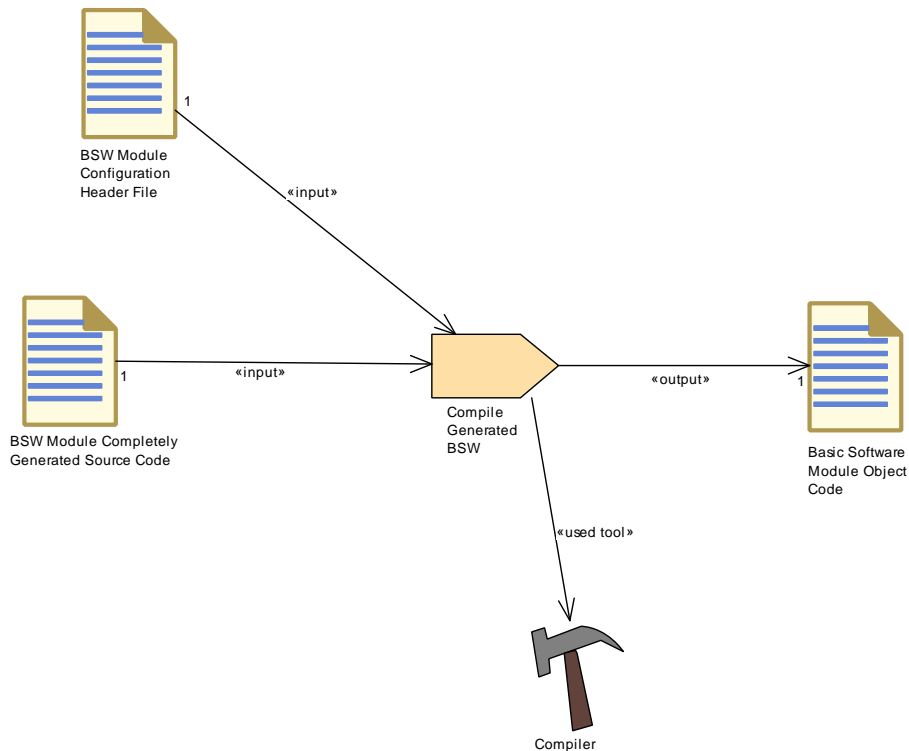


**Figure 3.134: Compile BSW Configuration Data**

<b>Task Definition</b>	<b>Compile BSW Configuration Data</b>		
<b>Package</b>	AUTOSAR Root::M2::Methodology::Methodology Library::Ecu::ECU Config Classes::Tasks		
<b>Brief Description</b>	Compile BSW Configuration Data during link time		
<b>Description</b>	Compile BSW Configuration Data during link-time- or post-build configuration to get the Basic Software Module Configuration Data Object Code used in the link steps.		
<b>Relation Type</b>	<b>Related Element</b>	<b>Mul.</b>	<b>Note</b>
Consumes	BSW Module Configuration Data Source Code	1	
Consumes	BSW Module Configuration Header File	1	
Consumes	Basic Software Module Core Header	1	
Produces	BSW Module Configuration Data Object Code	1	
Used tool	Compiler	1	

**Table 3.276: Compile BSW Configuration Data**

### 3.6.4.1.4 Compile Generated BSW

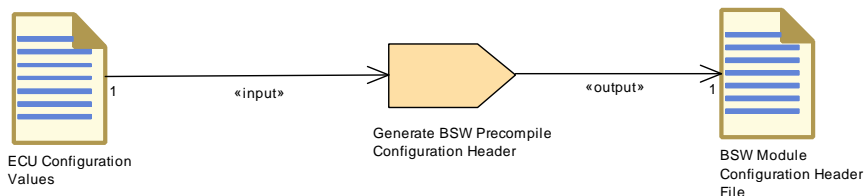


**Figure 3.135: Compile Generated BSW**

<b>Task Definition</b>	<b>Compile Generated BSW</b>		
<b>Package</b>	AUTOSAR Root::M2::Methodology::Methodology Library::Ecu::ECU Config Classes::Tasks		
<b>Brief Description</b>	Compile generated BSW in the pre-compile time:		
<b>Description</b>	Compile generated BSW in the pre-compile time: this generated BSW has been generated with a BSW Configuration generator which generates the complete configuration-specific code.		
<b>Relation Type</b>	<b>Related Element</b>	<b>Mul.</b>	<b>Note</b>
Consumes	BSW Module Completely Generated Source Code	1	
Consumes	BSW Module Configuration Header File	1	
Produces	Basic Software Module Object Code	1	
Used tool	Compiler	1	

**Table 3.277: Compile Generated BSW**

### 3.6.4.1.5 Generate BSW Precompile Configuration Header

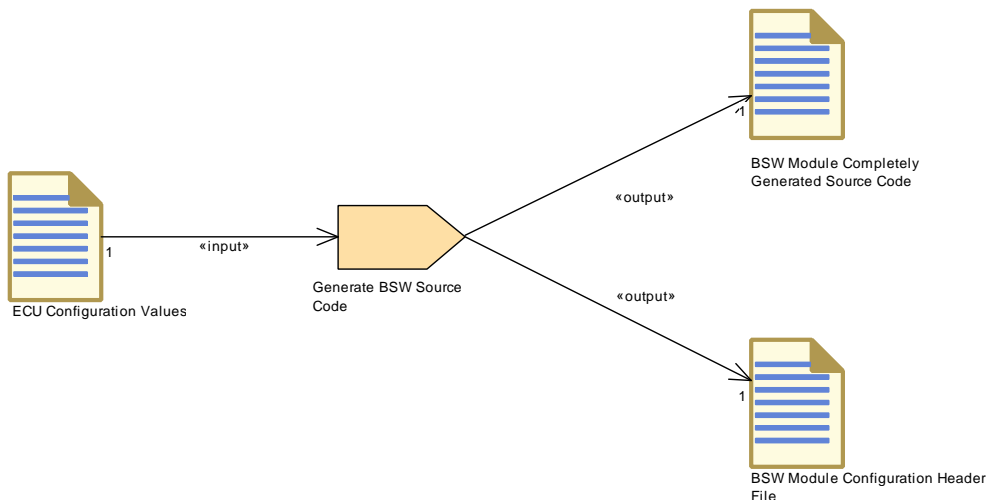


**Figure 3.136: Generate BSW Precompile Configuration Header**

<b>Task Definition</b>	<b>Generate BSW Precompile Configuration Header</b>		
<b>Package</b>	AUTOSAR Root::M2::Methodology::Methodology Library::Ecu::ECU Config Classes::Tasks		
<b>Brief Description</b>	Generate BSW Precompile Configuration Header		
<b>Description</b>	Generate BSW Pre-compile Configuration Header. The header is used for definition or declaration (in case source code is needed) of the pre-compile configuration data code.		
<b>Relation Type</b>	<b>Related Element</b>	<b>Mul.</b>	<b>Note</b>
Consumes	ECU Configuration Values	1	
Produces	BSW Module Configuration Header File	1	

**Table 3.278: Generate BSW Precompile Configuration Header**

**3.6.4.1.6 Generate BSW Source Code**



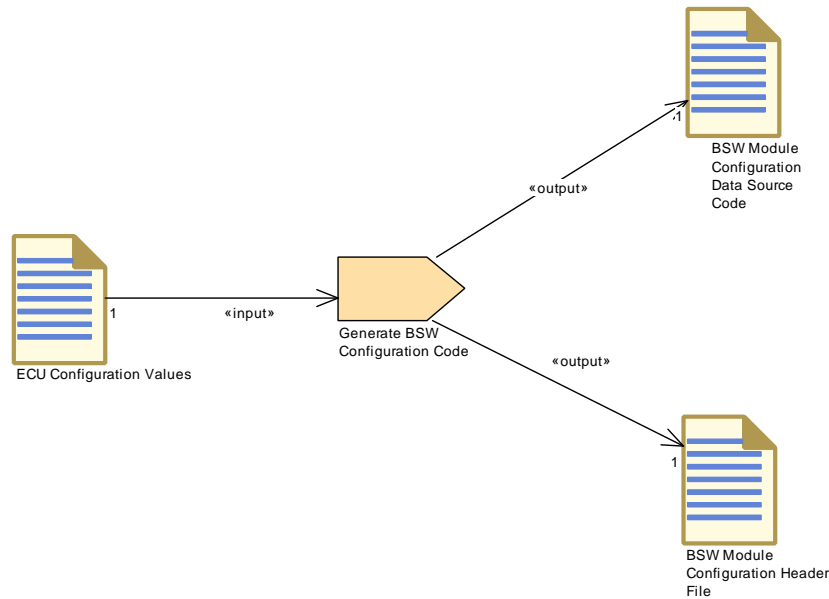
**Figure 3.137: Generate BSW Source Code**

<b>Task Definition</b>	<b>Generate BSW Source Code</b>		
<b>Package</b>	AUTOSAR Root::M2::Methodology::Methodology Library::Ecu::ECU Config Classes::Tasks		
<b>Brief Description</b>	Generate the source code of a module completely from its precompile configuration.		
<b>Description</b>	Generate the source code of a BSW module completely from its pre-compile configuration. A header file may be produced in addition, if required.		
<b>Relation Type</b>	<b>Related Element</b>	<b>Mul.</b>	<b>Note</b>
Consumes	ECU Configuration Values	1	
Produces	BSW Module Completely Generated Source Code	1	
Produces	BSW Module Configuration Header File	1	

**Table 3.279: Generate BSW Source Code**



### 3.6.4.1.7 Generate BSW Configuration Code



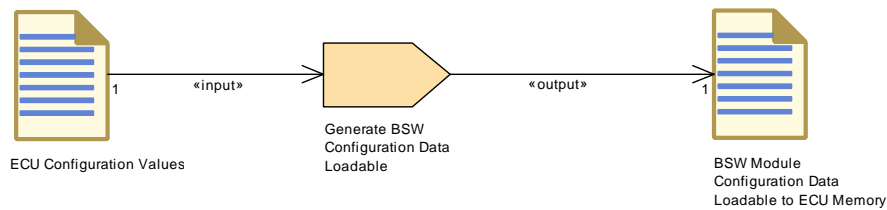
**Figure 3.138: Generate BSW Configuration Code**

<b>Task Definition</b>	<b>Generate BSW Configuration Code</b>		
<b>Package</b>	AUTOSAR Root::M2::Methodology::Methodology Library::Ecu::ECU Config Classes::Tasks		
<b>Brief Description</b>	Generate source code which implements configuration data for link- or compile-time configuration.		
<b>Description</b>	<p>A generator reads the relevant parameters from the ECU Configuration Description and creates a separate code file that implements the specified configuration. This task is used for link-time configuration, i.e. the configuration code can be produced at link-time of the core code or for compile-time configuration, if the configuration code cannot be put into a header file (e.g. for tables), even if the core code and the configuration code shall be compiled at the same time.</p> <p>A header file may be produced in addition, to declare the data.</p> <p>Furthermore the generator may produce extensions of the BSW module description artifacts as a result of configuration parameter values which are set at integration time.</p>		
<b>Relation Type</b>	<b>Related Element</b>	<b>Mul.</b>	<b>Note</b>
Performed by	<a href="#">ECU Integrator</a>	1	
Consumes	<a href="#">ECU Configuration Values</a>	1	
Consumes	<a href="#">BSW Module Generator</a>	0..1	This is an input in case a generator framework is used which has to run some module specific generator code.
Consumes	<a href="#">Build Action Manifest</a>	0..1	The task may be controlled by a Build Action Manifest.

<b>Relation Type</b>	<b>Related Element</b>	<b>Mul.</b>	<b>Note</b>
Consumes	BSW Vendor-Specific Configuration Parameter Definition	0..*	
Produces	BSW Module Configuration Data Source Code	1	
Produces	BSW Module Configuration Header File	1	
Produces	BSW Module Behavior Extension	0..1	
Produces	BSW Module Implementation Extension	0..1	
Produces	BSW Module Interface Extension	0..1	
Used tool	BSW Generator Framework	1	

**Table 3.280: Generate BSW Configuration Code**

**3.6.4.1.8 Generate BSW Configuration Data Loadable**

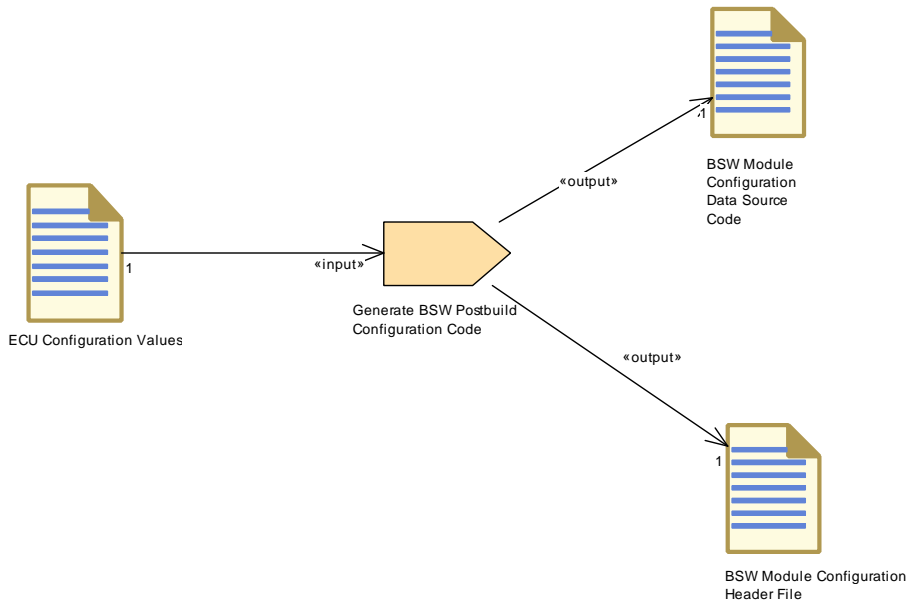


**Figure 3.139: Generate BSW Configuration Data Loadable**

<b>Task Definition</b>	<b>Generate BSW Configuration Data Loadable</b>		
<b>Package</b>	AUTOSAR Root::M2::Methodology::Methodology Library::Ecu::ECU Config Classes::Tasks		
<b>Brief Description</b>	Generate a postbuild-loadable set of data for the configuration of a BSW module.		
<b>Description</b>	Generate a postbuild-loadable set of data for the configuration of a BSW module.		
<b>Relation Type</b>	<b>Related Element</b>	<b>Mul.</b>	<b>Note</b>
Consumes	ECU Configuration Values	1	
Produces	BSW Module Configuration Data Loadable to ECU Memory	1	

**Table 3.281: Generate BSW Configuration Data Loadable**

### 3.6.4.1.9 Generate BSW Postbuild Configuration Code

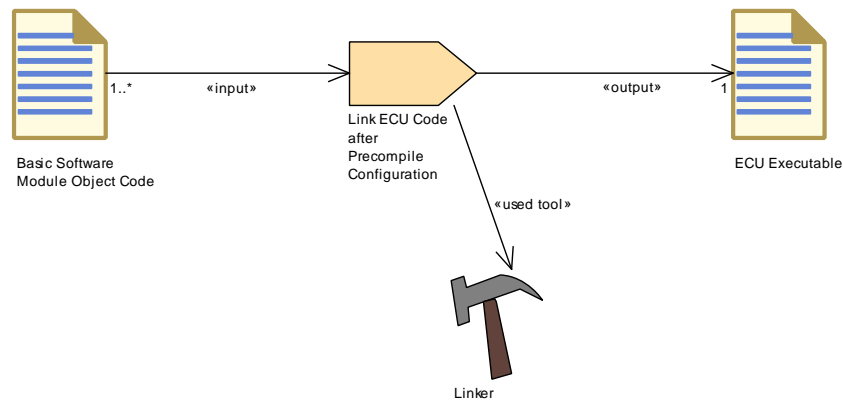


**Figure 3.140: Generate BSW Postbuild Configuration Code**

<b>Task Definition</b>	<b>Generate BSW Postbuild Configuration Code</b>		
<b>Package</b>	AUTOSAR Root::M2::Methodology::Methodology Library::Ecu::ECU Config Classes::Tasks		
<b>Brief Description</b>	Generate the code for data structures that can be used for postbuild configuration.		
<b>Description</b>	Generate the source code and associated header for data structures that can be used for selectable or loadable postbuild configuration.		
<b>Relation Type</b>	<b>Related Element</b>	<b>Mul.</b>	<b>Note</b>
Consumes	<a href="#">ECU Configuration Values</a>	1	
Produces	<a href="#">BSW Module Configuration Data Source Code</a>	1	
Produces	<a href="#">BSW Module Configuration Header File</a>	1	

**Table 3.282: Generate BSW Postbuild Configuration Code**

### 3.6.4.1.10 Link ECU after Precompile Configuration

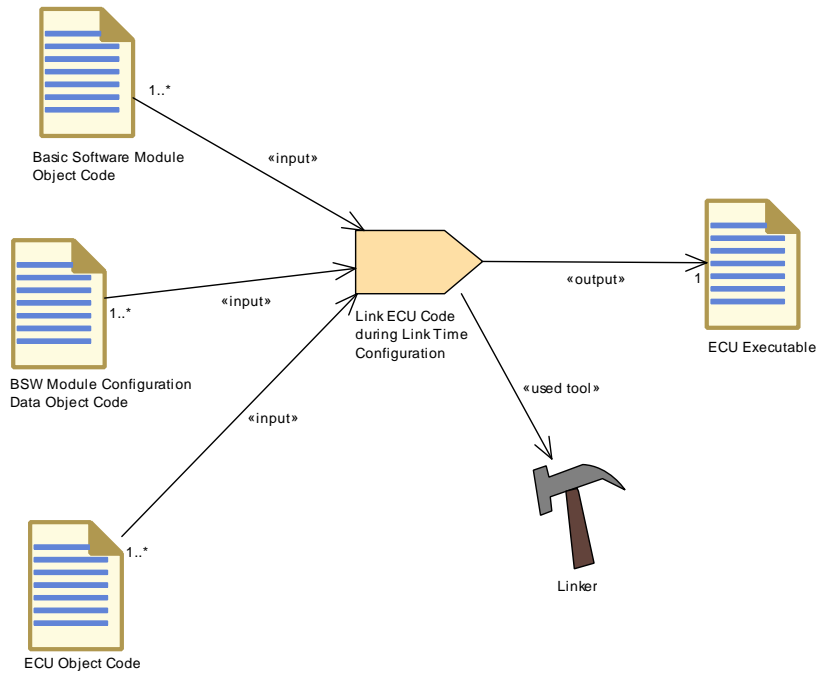


**Figure 3.141: Link ECU after Precompile Configuration**

<b>Task Definition</b>	<b>Link ECU Code after Precompile Configuration</b>		
<b>Package</b>	AUTOSAR Root::M2::Methodology::Methodology Library::Ecu::ECU Config Classes::Tasks		
<b>Brief Description</b>	Link the ECU code in the pre-compile time Configuration Class		
<b>Description</b>	Link the different BSW modules object code in the pre-compile Configuration Class. All parameters values for configurable elements have been already fixed and are effective after compilation time.		
<b>Relation Type</b>	<b>Related Element</b>	<b>Mul.</b>	<b>Note</b>
Consumes	Basic Software Module Object Code	1..*	
Produces	ECU Executable	1	
Used tool	Linker	1	

**Table 3.283: Link ECU Code after Precompile Configuration**

### 3.6.4.1.11 Link ECU Code During Link Time Configuration

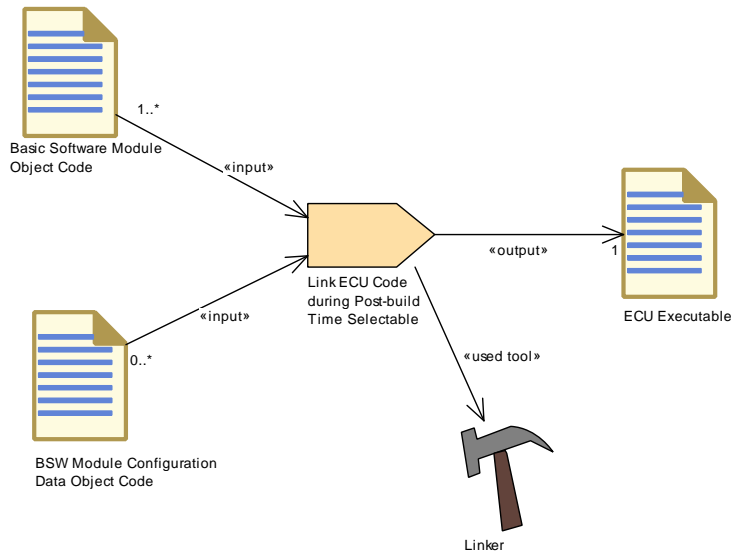


**Figure 3.142: Link ECU Code During Link Time Configuration**

<b>Task Definition</b>	<b>Link ECU Code during Link Time Configuration</b>		
<b>Package</b>	AUTOSAR Root::M2::Methodology::Methodology Library::Ecu::ECU Config Classes::Tasks		
<b>Brief Description</b>	Link ECU Code during Link Time		
<b>Description</b>	Link ECU Code during Link Time		
<b>Relation Type</b>	<b>Related Element</b>	<b>Mul.</b>	<b>Note</b>
Consumes	BSW Module Configuration Data Object Code	1..*	
Consumes	Basic Software Module Object Code	1..*	
Consumes	ECU Object Code	1..*	
Produces	ECU Executable	1	
Used tool	Linker	1	

**Table 3.284: Link ECU Code during Link Time Configuration**

**3.6.4.1.12 Link ECU Code During Post-build Time Selectable**

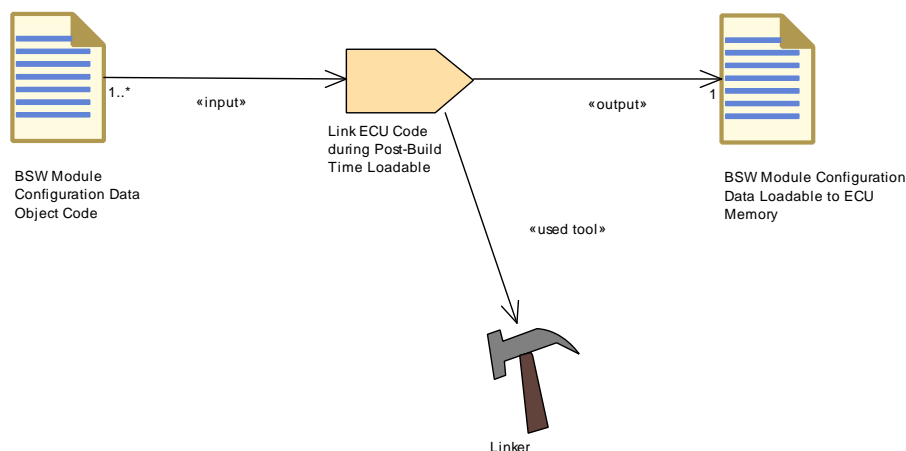


**Figure 3.143: Link ECU Code During Post-build Time Selectable**

<b>Task Definition</b>	<b>Link ECU Code during Post-build Time Selectable</b>		
<b>Package</b>	AUTOSAR Root::M2::Methodology::Methodology Library::Ecu::ECU Config Classes::Tasks		
<b>Brief Description</b>	Link ECU Code during Post-build Time Selectable		
<b>Description</b>	Link ECU Code during the Post-build Time Selectable allowing the definition, during boot time of a configuration set upon multiple ones.		
<b>Relation Type</b>	<b>Related Element</b>	<b>Mul.</b>	<b>Note</b>
Consumes	Basic Software Module Object Code	1..*	
Consumes	BSW Module Configuration Data Object Code	0..*	
Produces	ECU Executable	1	
Used tool	Linker	1	

**Table 3.285: Link ECU Code during Post-build Time Selectable**

### 3.6.4.1.13 Link ECU Code During Post-build Time Loadable



**Figure 3.144: Link ECU Code During Post-build Time Loadable**

<b>Task Definition</b>	<b>Link ECU Code during Post-Build Time Loadable</b>		
<b>Package</b>	AUTOSAR Root::M2::Methodology::Methodology Library::Ecu::ECU Config Classes::Tasks		
<b>Brief Description</b>	Link ECU Code during post-build time loadable .		
<b>Description</b>	Link ECU Code during post-build time loadable . The objects used for this link are coming from configuration data file that contain all configured parameters. The result of the link is a hex file that will be loadable in the ECU memory.		
<b>Relation Type</b>	<b>Related Element</b>	<b>Mul.</b>	<b>Note</b>
Consumes	BSW Module Configuration Data Object Code	1..*	
Produces	BSW Module Configuration Data Loadable to ECU Memory	1	
Used tool	Linker	1	

**Table 3.286: Link ECU Code during Post-Build Time Loadable**

## 3.6.4.2 Work Products

### 3.6.4.2.1 BSW Module Configuration Header File

<b>Artifact</b>	<b>BSW Module Configuration Header File</b>		
<b>Package</b>	AUTOSAR Root::M2::Methodology::Methodology Library::Ecu::ECU Config Classes::Work Products		
<b>Brief Description</b>	C-header file generated from the configuration data of a BSW module.		
<b>Description</b>	C-header file generated from the configuration data of a BSW module, defining the data (only possible for pre-compile configuration) or containing additional declarations (needed by generated configuration code only).		
<b>Kind</b>	Bound Source Code		
<b>Relation Type</b>	<b>Related Element</b>	<b>Mul.</b>	<b>Note</b>
Produced by	Generate BSW Configuration Code	1	
Produced by	Generate BSW Postbuild Configuration Code	1	
Produced by	Generate BSW Precompile Configuration Header	1	
Produced by	Generate BSW Source Code	1	
Produced by	Generate BSW and RTE	1	
Consumed by	Compile BSW Configuration Data	1	
Consumed by	Compile Configured BSW	1	
Consumed by	Compile Generated BSW	1	
Consumed by	Compile ECU Source Code	0..*	Meth.bindingTime = CodeGenerationTime

**Table 3.287: BSW Module Configuration Header File**

### 3.6.4.2.2 BSW Module Completely Generated Source Code

<b>Artifact</b>	<b>BSW Module Completely Generated Source Code</b>		
<b>Package</b>	AUTOSAR Root::M2::Methodology::Methodology Library::Ecu::ECU Config Classes::Work Products		
<b>Brief Description</b>	Generated BSW source code implementing the complete module after inclusion of pre-compilation configuration data.		
<b>Description</b>	Generated BSW source code implementing the complete module after inclusion of pre-compilation configuration data. In this case, no core code is delivered by the module vendor.		
<b>Kind</b>	Bound Source Code		
<b>Relation Type</b>	<b>Related Element</b>	<b>Mul.</b>	<b>Note</b>
Produced by	Generate BSW Source Code	1	
Consumed by	Compile Generated BSW	1	



<i>Relation Type</i>	<i>Related Element</i>	<i>Mul.</i>	<i>Note</i>
----------------------	------------------------	-------------	-------------

**Table 3.288: BSW Module Completely Generated Source Code**

### 3.6.4.2.3 BSW Module Configuration Data Source Code

<i>Artifact</i>	<b>BSW Module Configuration Data Source Code</b>		
<b>Package</b>	AUTOSAR Root::M2::Methodology::Methodology Library::Ecu::ECU Config Classes::Work Products		
<b>Brief Description</b>	BSW source code generated from configuration data, implementing only the data.		
<b>Description</b>	BSW source code generated from configuration data, implementing only the data.  In case of postbuild-selectable, this file may include several configuration data sets to be selected later.		
<b>Kind</b>	Bound Source Code		
<i>Relation Type</i>	<i>Related Element</i>	<i>Mul.</i>	<i>Note</i>
Produced by	Generate BSW Configuration Code	1	
Produced by	Generate BSW Postbuild Configuration Code	1	
Produced by	Generate BSW and RTE	1	
Consumed by	Compile BSW Configuration Data	1	
Consumed by	Compile ECU Source Code	0..*	Meth.bindingTime = CodeGenerationTime

**Table 3.289: BSW Module Configuration Data Source Code**

### 3.6.4.2.4 BSW Module Configuration Data Object Code

<i>Artifact</i>	<b>BSW Module Configuration Data Object Code</b>		
<b>Package</b>	AUTOSAR Root::M2::Methodology::Methodology Library::Ecu::ECU Config Classes::Work Products		
<b>Brief Description</b>	Generated data for link-time or postbuild configuration of a BSW module.		
<b>Description</b>	Generated & compiled configuration data for link-time or postbuild configuration of a BSW module.  In case of postbuild-selectable, this file may include several configuration data sets to be selected later.		
<b>Kind</b>	Object Code		
<i>Relation Type</i>	<i>Related Element</i>	<i>Mul.</i>	<i>Note</i>
Produced by	Compile BSW Configuration Data	1	

<i>Relation Type</i>	<i>Related Element</i>	<i>Mul.</i>	<i>Note</i>
Consumed by	<a href="#">Link ECU Code during Link Time Configuration</a>	1..*	
Consumed by	<a href="#">Link ECU Code during Post-Build Time Loadable</a>	1..*	
Consumed by	<a href="#">Link ECU Code during Post-build Time Selectable</a>	0..*	

**Table 3.290: BSW Module Configuration Data Object Code**

### 3.6.4.2.5 BSW Module Configuration Data Loadable to ECU Memory

<i>Artifact</i>	<b>BSW Module Configuration Data Loadable to ECU Memory</b>		
<i>Package</i>	AUTOSAR Root::M2::Methodology::Methodology Library::Ecu::ECU Config Classes::Work Products		
<i>Brief Description</i>	Generated loadable configuration data for post-build configuration of a BSW module.		
<i>Description</i>	Generated loadable configuration data for post-build configuration of a BSW module.		
<i>Kind</i>	Configuration Data Set		
<i>Relation Type</i>	<i>Related Element</i>	<i>Mul.</i>	<i>Note</i>
Aggregated by	<a href="#">ECU Software Delivered</a>	0..*	
Produced by	<a href="#">Generate BSW Configuration Data Loadable</a>	1	
Produced by	<a href="#">Link ECU Code during Post-Build Time Loadable</a>	1	

**Table 3.291: BSW Module Configuration Data Loadable to ECU Memory**

## A History of Constraints and Specification Items

### A.1 Constraint History of this Document according to AUTOSAR R4.1.1

N/A

#### A.1.1 Added Specification Items in R4.1.1

Number	Heading
[TR_METH_00001]	Definition of Binding Time for Tasks
[TR_METH_00002]	Definition of Binding Time for Artifacts
[TR_METH_00003]	Definition of Binding Time for Artifacts in the context of particular tasks
[TR_METH_01000]	Domains of the AUTOSAR methodology
[TR_METH_01001]	AUTOSAR methodology assets
[TR_METH_01002]	AUTOSAR methodology use cases
[TR_METH_01003]	Scope of the AUTOSAR methodology
[TR_METH_01004]	Support for various stakeholders by the AUTOSAR methodology
[TR_METH_01005]	Restrictions of AUTOSAR methodology
[TR_METH_01006]	General AUTOSAR methodology concepts
[TR_METH_01007]	Method Library
[TR_METH_01008]	Method Library Element
[TR_METH_01009]	Relation of Method Library and Method Library Element to the SPEM meta model
[TR_METH_01010]	Overview of Method Library Elements
[TR_METH_01011]	Task Definition
[TR_METH_01012]	Task semantics
[TR_METH_01013]	Task usage
[TR_METH_01014]	Work Product Definition
[TR_METH_01015]	Relationship between Roles and Work Products
[TR_METH_01017]	Artifact Definition
[TR_METH_01018]	Kinds of Artifacts
[TR_METH_01019]	Properties of Artifacts
[TR_METH_01020]	Relationship between Artifacts and meta model elements
[TR_METH_01021]	Deliverable Definition
[TR_METH_01022]	Aggregation of Work Products
[TR_METH_01023]	Role Definition
[TR_METH_01024]	Role assignment
[TR_METH_01025]	Tool Definition
[TR_METH_01026]	Guidance definition
[TR_METH_01027]	Guidance kinds
[TR_METH_01028]	Usage of tables
[TR_METH_01029]	Capability Patterns definition
[TR_METH_01030]	Composition of Capability Patterns
[TR_METH_01031]	Adaptability of the AUTOSAR methodology
[TR_METH_01032]	Use case elements
[TR_METH_01033]	Definition of Activities
[TR_METH_01034]	Composition of Activities
[TR_METH_01035]	Definition of Processes
[TR_METH_01036]	Description of overall Use Cases

[TR_METH_01037]	Precise description of Use Cases
[TR_METH_01038]	Detailed description of the work flow
[TR_METH_01039]	AUTOSAR System development overview
[TR_METH_01040]	Support of different system views
[TR_METH_01041]	Abstract system
[TR_METH_01042]	Overall technical system
[TR_METH_01043]	Sub-System
[TR_METH_01044]	Development of a functional view on the system
[TR_METH_01045]	Development of the <a href="#">Overall VFB System</a>
[TR_METH_01046]	Development of the system
[TR_METH_01047]	Two phase development approach
[TR_METH_01048]	The overall system
[TR_METH_01049]	Interaction between organizations
[TR_METH_01050]	<a href="#">Abstract System Description</a> activity
[TR_METH_01051]	Creation of an overall abstract system
[TR_METH_01052]	Definition of a constraints in the context of an abstract system
[TR_METH_01053]	Definition of a <a href="#">System Description</a> in the context of an abstract system
[TR_METH_01054]	Virtual Functional Bus
[TR_METH_01055]	<a href="#">Data Model Development</a> activity
[TR_METH_01056]	Definition of the VFB
[TR_METH_01057]	Top-Down approach
[TR_METH_01058]	Bottom-Up approach
[TR_METH_01059]	Kinds of <a href="#">VFB Atomic Software Components</a>
[TR_METH_01060]	<a href="#">Develop an Atomic Software Component</a> activity
[TR_METH_01061]	<a href="#">Develop Application Software</a> activity
[TR_METH_01065]	<a href="#">Develop System</a> and <a href="#">Develop Sub-System</a> activities
[TR_METH_01066]	Creation of a <a href="#">System Extract</a> and a <a href="#">ECU Extract</a>
[TR_METH_01067]	<a href="#">Abstract System Description</a> deliverable
[TR_METH_01068]	Inputs and Output of the <a href="#">Design System</a> activity
[TR_METH_01069]	Deployment of AUTOSAR Software Components
[TR_METH_01070]	Description of network signals
[TR_METH_01071]	Description of design constraints
[TR_METH_01075]	<a href="#">Design Sub-System</a> activity
[TR_METH_01076]	Collaboration between different organizations
[TR_METH_01077]	Transformation changes during the <a href="#">Design Sub-System</a> activity
[TR_METH_01078]	Mapping of different views
[TR_METH_01079]	Use Case: Substitution of existing components
[TR_METH_01080]	Use Case: Mapping of requirements to the solution
[TR_METH_01081]	Use Case: Reorganization of the software structure
[TR_METH_01082]	Use Case: Description of changes between different versions of <a href="#">System Descriptions</a>
[TR_METH_01083]	<a href="#">Design Basic Software</a> activity
[TR_METH_01084]	Separation of design and development of basic software
[TR_METH_01085]	<a href="#">Develop BSW Module</a> activity
[TR_METH_01086]	<a href="#">Integrate Software for ECU</a> activity
[TR_METH_01087]	Scope of <a href="#">Integrate Software for ECU</a> activity
[TR_METH_01088]	<a href="#">Prepare ECU Configuration</a> activity
[TR_METH_01089]	<a href="#">Configure BSW and RTE</a> activity
[TR_METH_01090]	<a href="#">Configure RTE</a> task
[TR_METH_01091]	<a href="#">Configure Debug</a> task
[TR_METH_01092]	Generating BSW modules, RTE, and OS source files
[TR_METH_01093]	Building <a href="#">ECU Executable</a>
[TR_METH_01095]	Configuration Class: Pre-compile Time

[TR_METH_01096]	Generating header files only
[TR_METH_01097]	Generating header and source files
[TR_METH_01098]	Configuration Class: Link Time
[TR_METH_01099]	Generation and compilation of BSW Configuration Code
[TR_METH_01100]	Definition of configuration data
[TR_METH_01101]	Separate compilation of module source and configuration file
[TR_METH_01102]	Linking process
[TR_METH_01103]	Re-generation in case of configuration value changes
[TR_METH_01104]	Configuration Class: Post-build Time Loadable
[TR_METH_01105]	Generate BSW Postbuild Configuration Code
[TR_METH_01106]	Generate BSW Configuration Data Loadable
[TR_METH_01107]	Configuration Class: Post-build Time Selectable
[TR_METH_01108]	Generating multiple configuration parameter sets
[TR_METH_01109]	Producing ECU-specific deliverables
[TR_METH_01110]	Development of Software Components
[TR_METH_01111]	Development of Basic Software modules
[TR_METH_01112]	Integration of AUTOSAR ECUs
[TR_METH_01113]	Usage of hyperlinks
[TR_METH_01120]	Definition of <a href="#">Consistency Needs</a>
[TR_METH_01121]	Building the AUTOSAR methodology document
[TR_METH_01122]	Relations between AUTOSAR <a href="#">Work Products</a>
[TR_METH_01123]	Traceability to external artifacts
[TR_METH_01124]	Documentation of <a href="#">Work Products</a>
[TR_METH_02000]	Use of AUTOSAR Services
[TR_METH_02001]	<a href="#">Define Cross-component Calibration Parameters</a> activity
[TR_METH_02002]	<a href="#">Define Local Calibration Parameters</a> activity
[TR_METH_02003]	<a href="#">Provide Unique Parameter Names</a> activity
[TR_METH_02004]	<a href="#">Re-generate RTE and Calibration Support</a> activity
[TR_METH_02005]	Memory sections for data and code
[TR_METH_02006]	E2E Protection
[TR_METH_02007]	<a href="#">Define E2E Protection Set</a> activity
[TR_METH_02008]	<a href="#">Regenerate E2E Protection Wrapper</a> activity
[TR_METH_02009]	Variation points in Variant Handling
[TR_METH_02010]	Predefined Variants in Variant Handling
[TR_METH_02011]	Types of binding times
[TR_METH_02012]	Definition of a binding time
[TR_METH_02013]	Latest Binding Time
[TR_METH_02014]	Actual Binding Time
[TR_METH_02015]	Definition of variants
[TR_METH_02016]	<a href="#">Evaluated Variant Set</a>
[TR_METH_02017]	Use of <a href="#">Predefined Variant</a>
[TR_METH_02018]	Choosing variants
[TR_METH_02020]	Definition of latest Binding Time for a variation point in the meta-model
[TR_METH_03000]	Name spaces via <a href="#">ARPackages</a>
[TR_METH_03001]	Reasons for name conflicts in “downstream” artifacts
[TR_METH_03002]	Conflict solution at system design time
[TR_METH_03003]	Conflict solution at coding time
[TR_METH_03004]	Conflict solution at ECU integration time
[TR_METH_03005]	Conflict solution via <a href="#">SymbolProps</a>
[TR_METH_03006]	Conflict solution via literal prefixes
[TR_METH_03007]	Conflict solution in names of runnable entities
[TR_METH_03008]	Conflict solution via <a href="#">FlatMap</a>
[TR_METH_03009]	Conflict solution via <a href="#">AliasNameSet</a>

[TR_METH_03010]	Conflict solution via API Infixes
-----------------	-----------------------------------

**Table A.1: Added Specification Items in 4.1.1**

## A.2 Constraint History of this Document according to AUTOSAR R4.1.2

N/A

### A.2.1 Added Specification Items in R4.1.2

Number	Heading
[TR_METH_01114]	Input sources for ECU Configuration
[TR_METH_01115]	A mix of parameters with different configuration classes within a BSW module is allowed
[TR_METH_01116]	ECU Configuration Value description contains the configuration of all BSW modules in a single ECU
[TR_METH_01117]	BSW implementation shall be chosen for each BSW module that is present in the ECU

**Table A.2: Added Specification Items in 4.1.2**

## A.3 Constraint History of this Document according to AUTOSAR R4.1.3

N/A

### A.3.1 Added Specification Items in R4.1.3

Number	Heading
[TR_METH_01125]	Create ECU System Description activity
[TR_METH_01126]	Using the System Extract as the structural basis for the ECU development
[TR_METH_01127]	Creating a new structure for the ECU development

**Table A.3: Added Specification Items in 4.1.3**

### A.3.2 Changed Specification Items in R4.1.3

Number	Heading
[TR_METH_01049]	Interaction between organizations
[TR_METH_01066]	Creation of a System Extract and an ECU Extract
[TR_METH_01075]	Design Sub-System activity
[TR_METH_01076]	Collaboration between different organizations

**Table A.4: Changed Specification Items in 4.1.3**