

Document Title	Specification of ECU Resource Template
Document Owner	AUTOSAR
Document Responsibility	AUTOSAR
Document Identification No	060
Document Classification	Standard

Document Version	2.3.1
Document Status	Final
Part of Release	4.1
Revision	2

Document Change History			
Date	Version	Changed by	Description
2013-10-24	2.3.1	AUTOSAR Release Management	<ul style="list-style-type: none"> • Layout update.
2013-01-21	2.3.0	AUTOSAR Administration	<ul style="list-style-type: none"> • Added specification item numbers for tracing.
2011-11-08	2.2.0	AUTOSAR Administration	<ul style="list-style-type: none"> • Added detailed change history (appendix C) • Added [constr_3500]
2010-07-29	2.1.0	AUTOSAR Administration	<ul style="list-style-type: none"> • Added Glossary appendix. • Updated category definitions to upper case.
2009-12-04	2.0.0	AUTOSAR Administration	<ul style="list-style-type: none"> • Reworked for Release 4.0.
2008-01-22	1.0.3	AUTOSAR Administration	<ul style="list-style-type: none"> • Correction of References

2007-12-05	1.0.2	AUTOSAR Administration	<ul style="list-style-type: none">• Document meta information extended• Small layout adaptations made
2007-01-31	1.0.1	AUTOSAR Administration	<ul style="list-style-type: none">• Legal disclaimer revised• Release Notes added• "Advice for users" revised• "Revision Information" added
2005-05-09	1.0.0	AUTOSAR Administration	Initial release

Disclaimer

This specification and the material contained in it, as released by AUTOSAR, is for the purpose of information only. AUTOSAR and the companies that have contributed to it shall not be liable for any use of the specification.

The material contained in this specification is protected by copyright and other types of Intellectual Property Rights. The commercial exploitation of the material contained in this specification requires a license to such Intellectual Property Rights.

This specification may be utilized or reproduced without any modification, in any form or by any means, for informational purposes only.

For any other purpose, no part of the specification may be utilized or reproduced, in any form or by any means, without permission in writing from the publisher.

The AUTOSAR specifications have been developed for automotive applications only. They have neither been developed, nor tested for non-automotive applications.

The word AUTOSAR and the AUTOSAR logo are registered trademarks.

Advice for users

AUTOSAR specifications may contain exemplary items (exemplary reference models, "use cases", and/or references to exemplary technical solutions, devices, processes or software).

Any such exemplary items are contained in the specifications for illustration purposes only, and they themselves are not part of the AUTOSAR Standard. Neither their presence in such specifications, nor any later documentation of AUTOSAR conformance of products actually implementing such exemplary items, imply that intellectual property rights covering such exemplary items are licensed under the same rules as applicable to the AUTOSAR Standard.

Table of Contents

1	Introduction	8
1.1	Scope of the ECU Resource Template	8
1.2	Overview ECU Resource Template	9
1.3	Requirements Traceability	10
1.4	Document Conventions	13
1.5	Requirements Tracing	15
2	General Hardware Description	16
2.1	Hardware Description Entity	17
2.2	Hardware Type	19
2.3	Hardware Element	20
2.3.1	Multiple occurrence of Hardware Elements	21
2.4	Hardware Pin and Pin Group	22
2.5	Hardware Connection	23
2.5.1	Scope of Connections	25
2.6	Hardware Category Definition	26
2.6.1	Vendor specific extensions of Hardware Category Definition	29
2.7	Ecu Resource Variant Handling	30
2.8	Documentation Support	31
2.9	Infrastructural aspects	31
3	Hardware Type Specific Description	32
3.1	HwElement categories	32
3.1.1	Ecu	32
3.1.2	Processing Unit	32
3.1.3	Micro-Controller	33
3.1.4	Memory	33
3.1.5	Communication Controller	33
3.1.6	Communication Transceiver	34
3.1.7	Digital IO	34
3.1.8	Analog IO	34
3.1.9	Timer	34
3.1.10	Watchdog	34
3.1.11	SensorActuator	35
3.2	HwPinGroup categories	35
3.2.1	CommunicationPort	35
3.3	HwPin categories	35
A	Examples	36
A.1	Hardware Element	36
A.2	Hierarchy of Hardware Elements	36
A.3	HwPinGroups and HwPins	37
A.4	Hardware Element Connection	38
A.5	Combined Example	39

A.5.1	Micro-controller description	40
A.5.2	Transceiver description	41
A.5.3	Ecu description	42
A.6	Attribute Definition	44
A.7	Attribute Value Example	45
B	Glossary	46
C	Change History	49
C.1	Change History between AUTOSAR R4.0.1 against R3.1.5	49
C.2	Change History between AUTOSAR R4.0.2 against R4.0.1	49
C.3	Change History between AUTOSAR R4.0.3 against R4.0.2	49
C.3.1	Added Constraints in R4.0.3	49
C.4	Change History between AUTOSAR R4.1.1 against R4.0.3	49
C.4.1	Added Constraints in R4.1.1	49
C.4.2	Added SWS Items in R4.1.1	49
D	Mentioned Class Tables	51

References

- [1] Requirements on ECU Resource Template
AUTOSAR_RS_ECUResourceTemplate
- [2] Meta Model
AUTOSAR_MMOD_MetaModel
- [3] Software Component Template
AUTOSAR_TPS_SoftwareComponentTemplate
- [4] Model Persistence Rules for XML
AUTOSAR_TR_XMLPersistenceRules
- [5] Standardization Template
AUTOSAR_TPS_StandardizationTemplate
- [6] Generic Structure Template
AUTOSAR_TPS_GenericStructureTemplate
- [7] IEEE standard for radix-independent floating-point arithmetic
(ANSI/IEEE Std 854-1987)
- [8] Software Process Engineering Meta-Model Specification
<http://www.omg.org/spec/SPEM/2.0/>

1 Introduction

One of the most prominent goals of AUTOSAR is the standardization of descriptions relevant for automotive software applications. In this context, the description of underlying ECU hardware is one of the major topics to resolve.

This document contains a specification of the modeling elements required to describe the hardware to the necessary extent. One aspect of the ECU Resource Template is to provide the system design engineer with the necessary information to assist the system partitioning, e.g. available memory and communication means of dedicated ECUs. Another aspect of the ECU Resource Template is to support the ECU Configuration engineers and tools with information required for the configuration of the micro-controller and ECU abstraction layer residing on a particular ECU.

The focus of the ECU Resource Template is to describe an already engineered piece of hardware, its content and structure. It is not in the focus of the ECU Resource Template to support the design of electronics hardware itself. There are established tools and exchange formats to aid in the design of electronics hardware already available. But such tools may be able to export their design using the AUTOSAR ECU Resource Template format for later usage in AUTOSAR design tools.

Where applicable, please consult the glossary and the abbreviation list contained in this document. The general characteristics of the ECU Resource Description are introduced followed by a detailed description of the hardware components inside the ECU.

1.1 Scope of the ECU Resource Template

The scope of the ECU Resource Template is the description of ECUs by means of the following basic building blocks:

- Hardware Elements
- Hardware PinGroups and Hardware Pins
- Hardware Connections

The HW Elements are the main describing elements of an ECU, For example: Processing units, memory, peripherals and sensors/actuators. HW Elements have a unique name and can be identified within an ECU description. HW Elements do not necessarily have to be described on the level of an ECU. It is possible to describe HW Elements as parts of other HW Elements. By this means a hierarchical description of HW Elements can be created.

HW Elements provide HW PinGroups and HW Pins for being interconnected among each others. HW PinGroups allow a rough description of how certain groups of HW Pins are arranged. The detailed description can be done using the HW Pins.

HW Connections are used to describe connections on several levels:

- connections between HW Elements
- connections between HW PinGroups
- connections between HW Pins

The different levels of abstraction allow to define and gather the required information for the different use-cases of the ECU Resource Template. For a rough understanding how the HW Elements are arranged in the ECU the connections between HW Elements are sufficient. To actually know at which HW Pin a certain signal is provided the detailed HW Pin connections are required.

1.2 Overview ECU Resource Template

Figure 1.1 depicts the main elements of an ECU Resource description and their inter-relations.

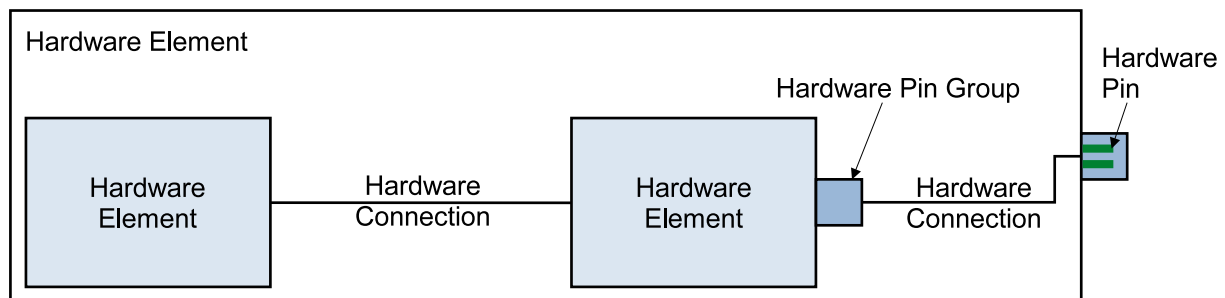

Figure 1.1: Overview of ECU Resource template

Modeling elements in the ECU Resource Template can be hierarchically organized. A particular ECU can be described as a hierarchical composition of micro-controllers and ECU Electronics. Each micro-controller is in turn composed of processing units, memory, peripherals and management units.

The same approach can be used to describe a particular ECU in combination with all sensors and actuators attached to the ECU.

The ECU Electronics is the hardware present on the ECU to guarantee the operation of the Processing Units (clock) as well as the conditioning of signals going out of the ECU or coming in (communication transceiver, amplifier, discrete electronics).

1.3 Requirements Traceability

Tracing of the Requirements on ECU Resource Template [1].

Requirement	Description	Satisfied by
[RS_ECUR_00005] Support configuration of Basic Software	The ECU Resource template shall provide means to describe hardware properties which are supporting the configuration of the AUTOSAR Basic Software.	The relationships between upstream templates and ECU Configuration are described in the AUTOSAR Metamodel [2]. The configuration parameters in the M1 model contain a number of tagged values with the mapping information.
[RS_ECUR_00003] Describe characteristic properties of specific hardware elements	The ECU Resource template shall provide means to describe the common and characteristic properties of hardware elements based on their kind.	The requirement is fulfilled by the defined categories and their attributes in chapter 3.
[RS_ECUR_00004] Describe generic hardware	The ECU Resource template shall provide means to describe hardware elements of any kind.	A HW vendor can extend the categories of AUTOSAR. New categories can be defined. Attributes can be added to existing categories and new literals to existing enumerations.
[RS_ECUR_00006] Describe connections between hardware elements	The ECU Resource template shall provide means to describe in an abstracted way how the individual hardware elements - in an ECU and on the outside of the ECU - are connected.	Hardware Connections can be described on several levels in the ECU Resource Template. These levels are described in chapter 2.5.
[RS_ECUR_00014] Timing properties of hardware	The ECU Resource template shall provide means to describe the timing properties for hardware I/O, e.g. the latency introduced by a digital I/O hardware port.	A HW vendor can extend the categories of AUTOSAR. New categories can be defined. New timing attributes can be added to existing categories and new literals to existing enumerations.
[RS_ECUR_00015] Describe variability of the hardware	It shall be possible to describe the variability the actual hardware provides.	The requirement is fulfilled by the AUTOSAR Variant Handling concept (chapter 2.7).
[RS_ECUR_00017] Documentation Support	The ECU Resource template shall provide means to add documentation to the hardware elements.	The requirement is fulfilled by the AUTOSAR Documentation Support concept (chapter 2.8).

Requirement	Description	Satisfied by
[RS_ECUR_00018] Support hardware descriptions from several sources	The ECU Resource template shall provide means to combine the hardware descriptions from several sources.	The containment hierarchy of hardware elements is not represented as a hierarchical structure in the XML description but as linked list. This modeling allows the usage of different ARXML files for the description of the container and the nested hardware elements (chapter 2.3).
[RS_ECUR_00007] Processing Unit specification	The ECU Resource template shall provide dedicated means to describe a processing unit. A processing unit shall be defined as the core of the micro controller / processor.	The requirement is fulfilled by the Processing Unit Category (chapter 3.1.2).
[RS_ECUR_00008] Available memory	The ECU Resource template shall provide dedicated means to describe memory segments. This includes all possible memory kinds like RAM, ROM, EEPROM, Flash, etc.	The requirement is fulfilled by the Memory Category (chapter 3.1.4).
[RS_ECUR_00009] Available communication means	The ECU Resource template shall provide dedicated means to describe communication hardware.	The requirement is fulfilled by the Hw Pin Group Categories. (chapter 3.2).
[RS_ECUR_00010] Available IO HW-Peripherals	The ECU Resource template shall provide dedicated means to describe IO-HW-Peripherals.	The requirement is fulfilled by the Digital IO (chapter 3.1.7) and Analog IO (chapter 3.1.8) categories.
[RS_ECUR_00016] IO-HW-Abstraction specification	The ECU Resource template shall provide the abstract connection information between the hardware sensor / actuator and the IO-HW peripheral using the IO-HW-Abstraction layer.	The requirement is fulfilled by the ECU Abstraction Software Component that is defined in the Software Component Template [3]. The ECU Abstraction is a special AtomicSwComponentType that resides between a software-component that wants to access ECU periphery and the Microcontroller Abstraction.
[RS_ECUR_00011] Available sensors and actuators	The ECU Resource template shall provide dedicated means to describe sensors and actuators.	The requirement is fulfilled by the SensorActuator Category (chapter 3.1.11).
[RS_ECUR_00012] Development according to the AUTOSAR Generic Structure Template document	The UML representation of the ECU Resource template SHALL be developed according to the AUTOSAR Generic Structure Template.	The requirement is fulfilled by the AUTOSAR development process.

Requirement	Description	Satisfied by
[RS_ECUR_00013] Transformation of ECU Resource template modeling according to the AUTOSAR Model Persistence Rules for XML	The XML representation for the ECU Resource template shall be derived from its UML representation according to the AUTOSAR Model Persistence Rules for XML.	The requirement is fulfilled by the AUTOSAR XML Schema generation process. The document called Model Persistence Rules [4] for XML describes how XML is used and how the meta-model designed in the "Ecu Resource Template" should be translated by the "Schema Generator" (MDS) into XML-Schema (XSD) "Data Exchange Format".

1.4 Document Conventions

Technical terms are typeset in mono spaced font, e.g. `PortPrototype`. As a general rule, plural forms of technical terms are created by adding "s" to the singular form, e.g. `PortPrototypes`. By this means the document resembles terminology used in the AUTOSAR XML Schema.

This document contains constraints in textual form that are distinguished from the rest of the text by a unique numerical constraint ID, a headline, and the actual constraint text starting after the `[` character and terminated by the `]` character.

The purpose of these constraints is to literally constrain the interpretation of the AUTOSAR meta-model such that it is possible to detect violations of the standardized behavior implemented in an instance of the meta-model (i.e. on M1 level).

Makers of AUTOSAR tools are encouraged to add the numerical ID of a constraint that corresponds to an M1 modeling issue as part of the diagnostic message issued by the tool.

The attributes of the classes introduced in this document are listed in form of class tables. They have the form shown in the example of the top-level element AUTOSAR:

Class	AUTOSAR			
Package	M2::AUTOSARTemplates::AutosarTopLevelStructure			
Note	Root element of an AUTOSAR description, also the root element in corresponding XML documents. Tags: xml.globalElement=true			
Base	ARObject			
Attribute	Datatype	Mul.	Kind	Note
adminData	AdminData	0..1	aggr	This represents the administrative data of an Autosar file. Tags: xml.sequenceOffset=10
arPackage	ARPackage	*	aggr	This is the top level package in an AUTOSAR model. Stereotypes: atpSplittable; atpVariation Tags: atp.Splitkey=shortName, variation Point.shortLabel vh.latestBindingTime=blueprintDerivationTime xml.sequenceOffset=30
introduction	Documentation Block	0..1	aggr	This represents an introduction on the Autosar file. It is intended for example to represent disclaimers and legal notes. Tags: xml.sequenceOffset=20

Table 1.2: AUTOSAR

The first rows in the table have the following meaning:

Class: The name of the class as defined in the UML model.

Package: The UML package the class is defined in. This is only listed to help locating the class in the overall meta model.

Note: The comment the modeler gave for the class (class note). Stereotypes and UML tags of the class are also denoted here.

Base Classes: If applicable, the list of direct base classes.

The headers in the table have the following meaning:

Attribute: The name of an attribute of the class. Note that AUTOSAR does not distinguish between class attributes and owned association ends.

Datatype: The datatype of an attribute of the class.

Mul.: The assigned multiplicity of the attribute, i.e. how many instances of the given data type are associated with the attribute.

Kind: Specifies, whether the attributes is aggregated in the class (*aggr*), an UML attribute in the class (*attr*), or just referenced by it (*ref*). Instance references are also indicated (*iref*) in this field.

Note: The comment the modeler gave for the class attribute (role note). Stereotypes and UML tags of the class are also denoted here.

The verbal forms for the expression of obligation specified in [TPS_STDT_00053] shall be used to indicate requirements, see Standardization Template, chapter Support for Traceability ([5]).

The representation of requirements in AUTOSAR documents follows the table specified in [TPS_STDT_00078], see Standardization Template, chapter Support for Traceability ([5]).

1.5 Requirements Tracing

The following table references the requirements specified in [1] and links to the fulfillments of these.

Requirement	Description	Satisfied by
[RS_ECUR_00003]	Describe characteristic properties of specific hardware elements	[TPS_ECUR_01003] [TPS_ECUR_01014]
[RS_ECUR_00004]	Describe generic hardware	[TPS_ECUR_01000] [TPS_ECUR_01001] [TPS_ECUR_01002] [TPS_ECUR_01003] [TPS_ECUR_01005]
[RS_ECUR_00005]	Support configuration of Basic Software	[TPS_ECUR_01015]
[RS_ECUR_00006]	Describe connections between hardware elements	[TPS_ECUR_01006]
[RS_ECUR_00007]	Processing Unit specification	[TPS_ECUR_01007] [TPS_ECUR_01034] [TPS_ECUR_01035] [TPS_ECUR_01036] [TPS_ECUR_01037] [TPS_ECUR_01038]
[RS_ECUR_00008]	Available memory	[TPS_ECUR_01008]
[RS_ECUR_00009]	Available communication means	[TPS_ECUR_01009] [TPS_ECUR_01010] [TPS_ECUR_01013]
[RS_ECUR_00010]	Available IO HW-Peripherals	[TPS_ECUR_01011]
[RS_ECUR_00011]	Available sensors and actuators	[TPS_ECUR_01012]
[RS_ECUR_00012]	Development according to the AUTOSAR Generic Structure Template document	[TPS_ECUR_01032]
[RS_ECUR_00013]	Transformation of ECU Resource template modeling according to the AUTOSAR Model Persistence Rules for XML	[TPS_ECUR_01033]
[RS_ECUR_00014]	Timing properties of hardware	[TPS_ECUR_01031]
[RS_ECUR_00015]	Describe variability of the hardware	[TPS_ECUR_01003] [TPS_ECUR_01014] [TPS_ECUR_01029]
[RS_ECUR_00016]	IO-HW-Abstraction specification	[TPS_ECUR_01006]
[RS_ECUR_00017]	Documentation Support	[TPS_ECUR_01030]
[RS_ECUR_00018]	Support hardware descriptions from several sources	[TPS_ECUR_01018]

2 General Hardware Description

The ECU Resource Template utilizes the basic building blocks

- hardware elements
- hierarchies of hardware elements
- hardware pins
- hardware pin groups
- hardware connections

to describe the relevant aspects of the actual hardware. The ECU Resource Template allows however to choose the appropriate level of detail in the description of the hardware, depending on the use case. It also allows to describe arbitrary hardware and its connections.

[TPS_ECUR_01015] Support of AUTOSAR Basic Software configuration [The primary goal of the ECU Resource Template is to support the configuration of the AUTOSAR Basic Software by providing information on the respective hardware and the how the hardware is connected to each other.] ([RS_ECUR_00005](#))

In figure [2.1](#) the overview of the involved classes is shown.

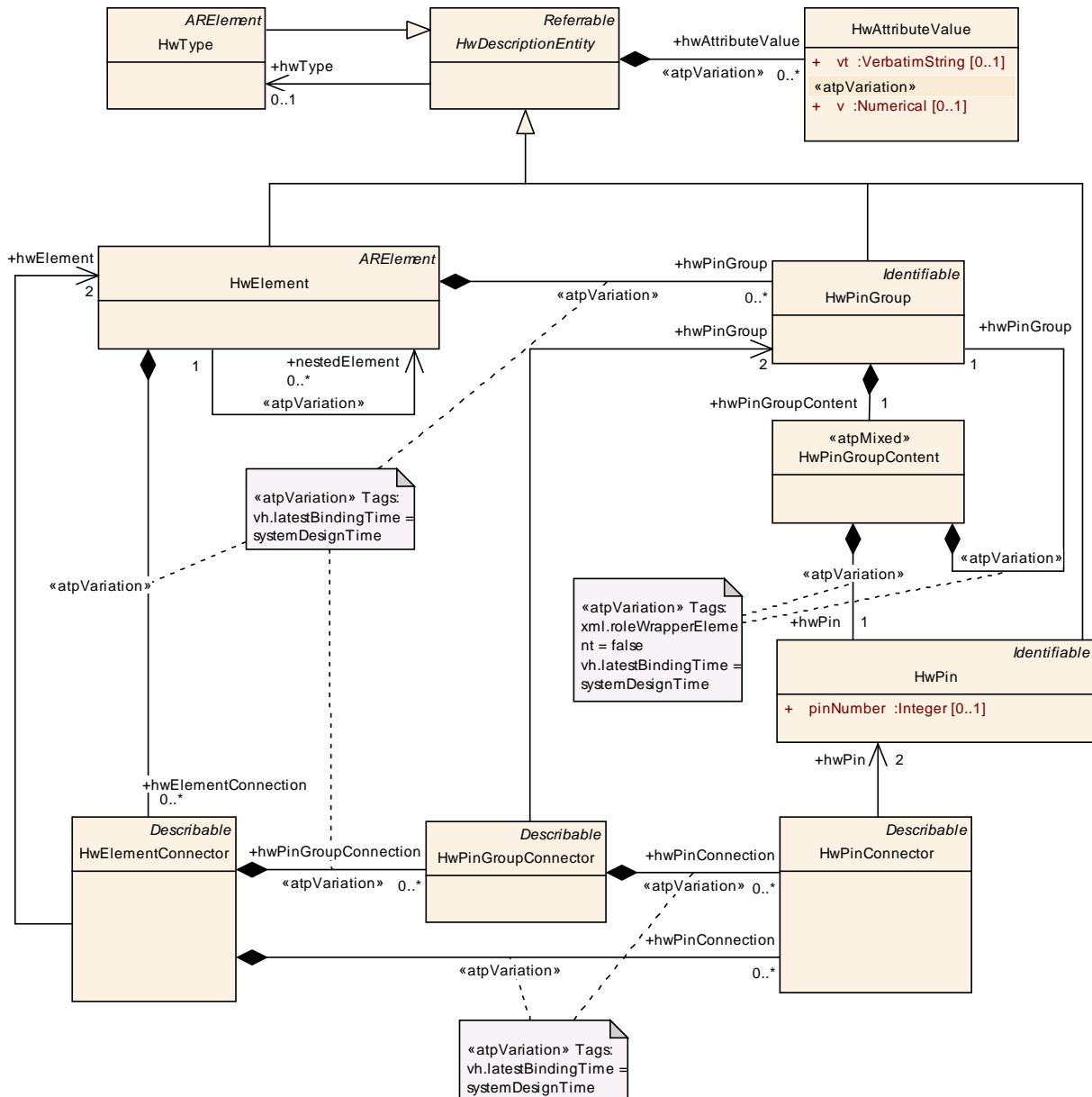

Figure 2.1: Overview of ECU Resource template classes

2.1 Hardware Description Entity

In order to allow flexibility of the ECU Resource Template with respect to the description of a multitude of hardware types the ECU Resource Template only provides the generic means to describe hardware elements and their connectivity. The description of specific attributes can be provided according to section 2.6.

[TPS_ECUR_01002] Definition of Hardware Elements [The `HwDescriptionEntity` allows to provide a set of attribute values which are defined by one or more hardware categories.] ([RS_ECUR_00004](#))

Please refer to chapter 3 for details on the actual applicable hardware categories and corresponding attributes.

The `HwDescriptionEntity` is able to specify for which hardware categories (see section 2.6) this `HwDescriptionEntity` is applicable. It is possible to define several references in the role `hwCategory`.

- **[TPS_ECUR_01000] Definition of `HwCategory`** [It shall be possible to reference different kinds of `HwCategory` elements in order to describe different aspects of the hardware (e.g. a Can controller with an integrated Spi channel).]([RS_ECUR_00004](#))
- **[TPS_ECUR_01001] Extension of `HwCategory`** [It shall be possible to extend the standardized `HwCategory` specification with additional attributes (see section 2.6.1).]([RS_ECUR_00004](#))

For a description of the `hwType` reference please refer to section 2.2.

Each `HwDescriptionEntity` may aggregate several `HwAttributeValue` elements.

Class	HwDescriptionEntity (abstract)			
Package	M2::AUTOSARTemplates::EcuResourceTemplate			
Note	This meta-class represents the ability to describe a hardware entity.			
Base	ARObject, Referrable			
Attribute	Datatype	Mul.	Kind	Note
hwAttributeValue	HwAttributeValue	*	aggr	This aggregation represents a particular hardware attribute value. Stereotypes: atpVariation Tags: vh.latestBindingTime=systemDesignTime xml.sequenceOffset=50
hwCategory	HwCategory	*	ref	One of the associations representing one particular category of the hardware entity. Tags: xml.sequenceOffset=30
hwType	HwType	0..1	ref	This association is used to assign an optional HwType which contains the common attribute values for all occurrences of this HwDescriptionEntity. Note that HwTypes can not be redefined and therefore shall not have a hwType reference.

Table 2.1: HwDescriptionEntity

[TPS_ECUR_01014] Definition of `HwAttributeValue` [The `HwAttributeValue` is used to specify one value for a predefined attribute. The link of the attribute is defined with the reference to `HwAttributeDef` in the role `hwAttributeDef` which is subject to variant handling.]([RS_ECUR_00003](#), [RS_ECUR_00015](#))

The definition of attributes is described in section 2.6.

[TPS_ECUR_01003] Values of hardware attributes [The actual value of a [HwAttributeValue](#) can be provided in one of two ways:

- **vt** - the value is specified in a textual representation.
- **v** - the value is specified in a numerical representation. The actual value can be subject to variant handling (see also section 2.7).

] ([RS_ECUR_00003](#), [RS_ECUR_00004](#), [RS_ECUR_00015](#))

Class	HwAttributeValue			
Package	M2::AUTOSARTemplates::EcuResourceTemplate::HwElementCategory			
Note	This metaclass represents the ability to assign a hardware attribute value. Note that v and vt are mutually exclusive.			
Base	ARObject			
Attribute	Datatype	Mul.	Kind	Note
annotation	Annotation	0..1	aggr	Optional annotation that can be added to each HwAttributeValue.
hwAttributeDef	HwAttributeDef	1	ref	This association represents the definition of the particular hardware attribute value.
v	Numerical	0..1	attr	This represents a numerical hardware attribute value. Stereotypes: atpVariation Tags: vh.latestBindingTime=systemDesignTime
vt	VerbatimString	0..1	ref	This represents a textual hardware attribute value.

Table 2.2: HwAttributeValue

2.2 Hardware Type

[TPS_ECUR_01016] Definition of HwType [The [HwType](#) is used to gather attribute values for elements which can occur several times in an Ecu and will not change due to their multiple usage.]

For details on the multiple occurrence of hardware elements please refer to section 2.3.1.

A [HwType](#) is an [ARElement](#) which inherits from [HwDescriptionEntity](#). The features of [ARElement](#) allow the hardware type to have a name and stand for its own inside some package. The features of [HwDescriptionEntity](#) allow the hardware type to describe hardware categories and attribute values (see section 2.1).

[TPS_ECUR_01017] Attribute values defined in the HwType are applicable for all occurrences of this HwType [The attribute values defined in the [HwType](#) are applicable for all occurrences of this [HwType](#), although it is possible to override the value in the [HwElement](#) (see section 2.3).]

[constr_3511] HwType shall not have a reference to another HwType [A [HwType](#) (being a [HwDescriptionEntity](#)) shall not have a reference to another [HwType](#) in the role [hwType](#). The definition of [HwTypes](#) is not hierarchical.]

The [HwType](#) does not specify any structural features of the hardware. The description of hardware pin groups, hardware pins and hardware connections is only possible at the hardware element level.

Class	HwType			
Package	M2::AUTOSARTemplates::EcuResourceTemplate::HwElementCategory			
Note	This represents the ability to describe Hardware types on an abstract level. The particular types of hardware are distinguished by the category. This category determines the applicable attributes. The possible categories and attributes are defined in HwCategory . Tags: atp.recommendedPackage=HwTypes			
Base	ARElement , ARObject , CollectableElement , HwDescriptionEntity , Identifiable , MultilanguageReferrable , PackageableElement , Referrable			
Attribute	Datatype	Mul.	Kind	Note
–	–	–	–	–

Table 2.3: HwType

2.3 Hardware Element

[TPS_ECUR_01005] The HwElement describes one piece of hardware [The [HwElement](#) describes how one piece of hardware - as a building block - is contributing to the overall circuit describing the ECU. It can be used to describe any hardware, independent of their granularity and scale. So an ECU can be described as a whole, the connected sensors and actuators, the built-in micro-controller and communication transceiver. But also the processing cores and the memory segments inside the micro-controller can be described.] ([RS_ECUR_00004](#))

[TPS_ECUR_01018] HwElement is self contained [Each [HwElement](#) can be described in a self contained way because the [HwElement](#) is an [ARElement](#).] ([RS_ECUR_00018](#))

Each [HwElement](#) inherits from [HwDescriptionEntity](#) and is therefore capable to describe a set of attributes (see section 2.1 for details).

[TPS_ECUR_01019] HwElement can refer to a HwType [Each [HwElement](#) can optionally refer to a [HwType](#) element in the role [hwType](#). In the [HwType](#) the attribute values, which are common for all occurrences of the hardware type, are described. In case the [HwElement](#) provides an attribute value which is also provided in the referenced [HwType](#) the attribute value from the [HwElement](#) takes precedence.]

The features of the [nestedElement](#) reference are specified in section 2.3.1.

The `HwElement` can describe several `HwPinGroup` elements which are contained in the role `hwPinGroup` (for details on the `HwPinGroup` refer to section 2.4).

The hardware element can describe several `HwElementConnector` elements which are contained in the role `hwElementConnection` (for details on the `HwElementConnector` refer to section 2.5).

Class	HwElement			
Package	M2::AUTOSARTemplates::EcuResourceTemplate			
Note	This represents the ability to describe Hardware Elements on an instance level. The particular types of hardware are distinguished by the category. This category determines the applicable attributes. The possible categories and attributes are defined in <code>HwCategory</code> . Tags: atp.recommendedPackage=HwElements			
Base	ARElement , ARObject , CollectableElement , HwDescriptionEntity , Identifiable , MultilanguageReferrable , PackageableElement , Referrable			
Attribute	Datatype	Mul.	Kind	Note
hwElementConnection	HwElementConnector	*	aggr	This represents one particular connection between two hardware elements. Stereotypes: atpVariation Tags: vh.latestBindingTime=systemDesignTime xml.sequenceOffset=110
hwPinGroup	HwPinGroup	*	aggr	This aggregation is used to describe the connection facilities of a hardware element. Note that hardware element has no pins but only pingroups. Stereotypes: atpVariation Tags: vh.latestBindingTime=systemDesignTime xml.sequenceOffset=90
nestedElement	HwElement	*	ref	This association is used to establish hierarchies of hw elements. Note that one particular <code>HwElement</code> can be target of this association only once. I.e. multiple instantiation of the same <code>HwElement</code> is not supported (at any hierarchy level). Stereotypes: atpVariation Tags: vh.latestBindingTime=systemDesignTime xml.sequenceOffset=70

Table 2.4: HwElement

2.3.1 Multiple occurrence of Hardware Elements

[TPS_ECUR_01020] Hierarchy of hardware [The hierarchy of hardware is described via referencing the contained hardware elements with the role `nestedElement`. The containment hierarchy of hardware elements is not represented as a hierarchical structure in the XML description but as linked list.]

This modeling allows the usage of different ARXML files for the description of the container hardware element and the nested hardware elements. E.g. the CPU is described by a Semiconductor-Vendor, the project specific usage of such a CPU is described by the ECU vendor.

[constr_3512] No support of multiple instantiation [An essential constraint is that each `HwElement` can only be target of one `nestedElement` reference. This means that there is no concept of multiple instantiation of hardware elements. If the same hardware element shall be used several times (using the `nestedElement` reference) each occurrence has to have its own description. This is also true for nested elements of the referenced nested element.]

Thus the hardware element and all its structural features (hardware pin groups, hardware pins and hardware connections) need to be cloned. There is however the possibility to reference the same `HwType` from several `HwElement` clones.

2.4 Hardware Pin and Pin Group

The `HwPinGroup` allows to describe dedicated channels of connectivity for hardware elements. It can be used to describe grouped hardware ports like ADC and DIO. It can structure the port information hierarchically. At the detailed level it can be used to describe individual hardware pins.

Each `HwPinGroup` is `Identifiable`. A `HwPinGroup` can only exist inside a `HwElement` or another `HwPinGroup`.

Each `HwPinGroup` inherits from `HwDescriptionEntity` and is therefore capable to describe a set of attributes (see section 2.1 for details).

The content of the `HwPinGroup` is aggregated in the role `hwPinGroupContent`.

Class	HwPinGroup			
Package	M2::AUTOSARTemplates::EcuResourceTemplate			
Note	This meta-class represents the ability to describe groups of pins which are used to connect hardware elements. This group acts as a bundle of pins. Thereby they allow to describe high level connections. Pin groups can even be nested.			
Base	ARObject, HwDescriptionEntity , Identifiable , MultilanguageReferrable , Referrable			
Attribute	Datatype	Mul.	Kind	Note
hwPinGroupContent	HwPinGroupContent	1	aggr	This aggregation describes the contained pins/pin groups.

Table 2.5: HwPinGroup

The `HwPinGroupContent` can contain `HwPinGroup` and `HwPin`. The `HwPinGroupContent` is defined as «atpMixed» (see Generic Structure Template [6]). The elements contained in the `HwPinGroupContent` (`HwPinGroup` and `HwPin`) can occur in an arbitrary order and multiple times. This allows to describe the ordered occurrence

of pins and pin groups within pin groups. One major use-case is to describe physical connectors and plugs with chambers and pins.

Class	«atpMixed» HwPinGroupContent			
Package	M2::AUTOSARTemplates::EcuResourceTemplate			
Note	This meta-class specifies a mixture of hwPins and hwPinGroups.			
Base	ARObject			
Attribute	Datatype	Mul.	Kind	Note
hwPin	HwPin	1	aggr	This aggregation represents a hardware pin in a hardware pin group. Stereotypes: atpVariation Tags: vh.latestBindingTime=systemDesignTime xml.roleWrapperElement=false
hwPinGroup	HwPinGroup	1	aggr	This aggregation represents a nested hardware pin group. Stereotypes: atpVariation Tags: vh.latestBindingTime=systemDesignTime xml.roleWrapperElement=false

Table 2.6: HwPinGroupContent

Each [HwPin](#) is [Identifiable](#). A [HwPin](#) can only exist inside a [HwPinGroupContent](#) and therefore indirectly in a [HwPinGroup](#).

Each [HwPin](#) inherits from [HwDescriptionEntity](#) and is therefore capable to describe a set of attributes (see section 2.1 for details).

Class	HwPin			
Package	M2::AUTOSARTemplates::EcuResourceTemplate			
Note	This meta-class represents the possibility to describe a hardware pin.			
Base	ARObject, HwDescriptionEntity , Identifiable , MultilanguageReferrable , Referrable			
Attribute	Datatype	Mul.	Kind	Note
pinNumber	Integer	0..1	attr	This attribute contains the physical pin number.

Table 2.7: HwPin

2.5 Hardware Connection

Connections can be described on several levels in the ECU Resource Template. This allows the expression of details on the needed level of abstraction.

[TPS_ECUR_01006] Connections between [HwElements](#) [The [HwElementConnector](#) allows to describe the connection between two [HwElements](#). It is not meant to describe the actual technical connectivity between the two hardware elements. It is used to describe the general connectivity between the hardware elements.] ([RS_ECUR_00006](#), [RS_ECUR_00016](#))

Class	HwElementConnector			
Package	M2::AUTOSARTemplates::EcuResourceTemplate			
Note	This meta-class represents the ability to connect two hardware elements. The details of the connection can be refined by hwPinGroupConnection .			
Base	ARObject, Describable			
Attribute	Datatype	Mul.	Kind	Note
hwElement	HwElement	2	ref	This association connects two hardware elements.
hwPinConnection	HwPinConnector	*	aggr	This represents one particular connection between two hardware pins. This connection shall be used if pin-to-pin-connection is to be described but no description of the connection between the hierarchical composition of HwPinGroups (using HwPinGroupConnector) is required. Stereotypes: atpVariation Tags: vh.latestBindingTime=systemDesignTime xml.sequenceOffset=60
hwPinGroupConnection	HwPinGroupConnector	*	aggr	This represents one particular connection between two hardware pin groups. Stereotypes: atpVariation Tags: vh.latestBindingTime=systemDesignTime xml.sequenceOffset=50

Table 2.8: HwElementConnector

The [HwPinGroupConnector](#) allows to describe the connection between two [HwPinGroups](#).

Class	HwPinGroupConnector			
Package	M2::AUTOSARTemplates::EcuResourceTemplate			
Note	This meta-class represents the ability to connect two pin groups.			
Base	ARObject, Describable			
Attribute	Datatype	Mul.	Kind	Note
hwPinConnection	HwPinConnector	*	aggr	This represents one particular connection between two hardware pins. The connected pins must match the connection provided by the parent hwPinGroupConnection . Stereotypes: atpVariation Tags: vh.latestBindingTime=systemDesignTime
hwPinGroup	HwPinGroup	2	ref	This association connects two hardware pin groups.

Table 2.9: HwPinGroupConnector

The [HwPinConnector](#) allows to describe the connection between two [HwPins](#).

Class	HwPinConnector			
Package	M2::AUTOSARTemplates::EcuResourceTemplate			
Note	This meta-class represents the ability to connect two pins.			
Base	ARObject, Describable			
Attribute	Datatype	Mul.	Kind	Note
hwPin	HwPin	2	ref	This association connects two hardware pins.

Table 2.10: HwPinConnector

2.5.1 Scope of Connections

The hardware connections are part of a hardware element and connect the two artifacts via references to the description of the artifacts. In principle such references can refer to any hardware element and its features in the input information. But the scope of connections is restricted based on the containing hardware element of the hardware connection.

[constr_3513] Scope of connections [Each hardware connection shall only connect features which both are in the hierarchical scope of the hardware element. The hierarchical scope encloses

- all features belonging to the hardware element containing the connection
- all features belonging to hardware elements which are referenced directly and indirectly in the [nestedElement](#) relation from the hardware element containing connection.

]

Especially it is allowed to specify connections in hardware elements which are in deeper hierarchical level and also connections which cross hierarchical levels.

In the example from figure [A.1](#) the following connections are allowed:

- connections specified in the scope of hardware element "MyEcu"
 - all the shown connections can be specified on this level
 - even the connections inside another hierarchical hardware element (e.g. between "Pu1" and "Can") can be specified on this level
 - even the connections crossing hierarchical levels (e.g. between "Can" and "Trcv") can be specified on this level
- connections specified in the scope of hardware element "MicroController"
 - only the connections inside the hardware element "MicroController" (e.g. between "Pu1" and "Can") can be specified.

2.6 Hardware Category Definition

The definition of dedicated hardware types allows a flexible usage of the ECU Resource Template. Since the definition of hardware types and the applicable attributes is specified as an AUTOSAR XML file itself it can be updated and extended without the needs to update the AUTOSAR XML-Schema.

In figure 2.2 the relationship between the definition and the description of hardware is shown.

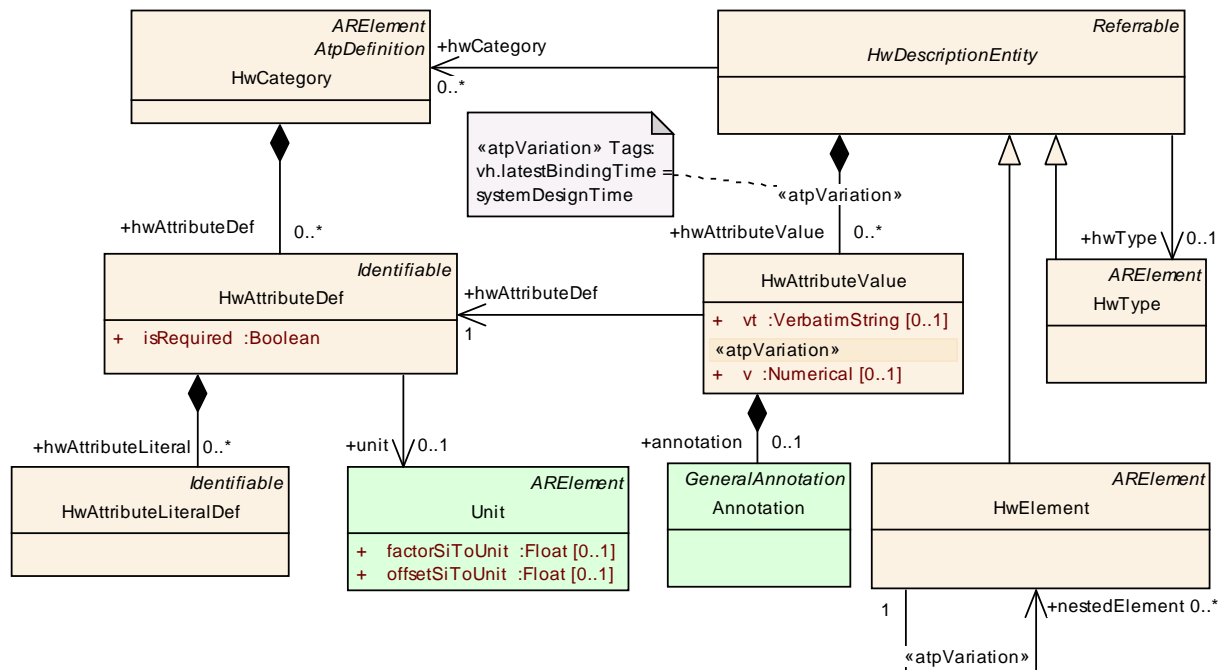

Figure 2.2: Definition of hardware categories

The element `HwCategory` specifies what type of hardware is defined. This can be a for example a memory segment, a processing unit, a communication transceiver etc.

The `HwCategory` is later referenced from the `HwDescriptionEntity` in the role `hwCategory` to describe what type of hardware is described. Possible values for the `shortName` of the `HwCategory` element are defined in table 3.1 and table 3.5.

The `HwCategory` may contain several `HwAttributeDef` elements.

Class	HwCategory			
Package	M2::AUTOSARTemplates::EcuResourceTemplate::HwElementCategory			
Note	This metaclass represents the ability to declare hardware categories and its particular attributes. Tags: atp.recommendedPackage=HwCategorys			
Base	ARElement, ARObjct, AtpDefinition, CollectableElement, Identifiable, Multilanguage Referrable, PackageableElement, Referrable			
Attribute	Datatype	Mul.	Kind	Note

Attribute	Datatype	Mul.	Kind	Note
hwAttributeDef	HwAttributeDef	*	aggr	This aggregation describes particular hardware attribute definition.

Table 2.11: HwCategory

The `HwAttributeDef` specifies one attribute which is applicable for the `HwCategory`.

The name of the attribute is defined in the `shortName`.

The type of the attribute is specified by the `category`. Applicable values for the `category` of `HwAttributeDef` are defined in table 2.12.

[constr_3500] category of HwAttributeDef shall not be extended [In contrast to the general rule that `category` can be extended by user-specific values it is **not allowed** to extend the meaning of the attribute `category` of meta-class `HwAttributeDef`]

Category	Description
BOOLEAN	Defines a boolean attribute. The values of a boolean attribute can be provided in <ul style="list-style-type: none"> textual format 'true' / 'false' (using the <code>vt</code> element of <code>HwAttributeValue</code>) numerical format '1' (true) / '0' (false) (using the <code>v</code> element of <code>HwAttributeValue</code>)
INTEGER	Defines an integer attribute. The values of an integer attribute can be a signed / unsigned whole number. The value has to fit in a signed / unsigned 64-bit number space.
FLOAT	Defines a float attribute. The value of a float attribute is represented as an IEEE double-precision 64-bit floating point of the IEEE 754-1985 standard [7].
ENUMERATION	Defines an enumeration attribute. The possible enumeration literals are defined with the element <code>hwAttributeLiteral</code> The value of an enumeration attribute is provided as text in the <code>vt</code> element of <code>HwAttributeValue</code> .
STRING	Defines a string attribute. The value of a string attribute is provided as text in the <code>vt</code> element of <code>HwAttributeValue</code> .

Table 2.12: Hardware Attribute Categories

The element `isRequired` specifies whether the attribute is mandatory for the defined category.

[TPS_ECUR_01031] Definition of attribute unit [Optionally the attribute definition can have a reference to a `Unit` element which specifies in which unit the value of this attribute shall be specified.] ([RS_ECUR_00014](#))

For details on the [Unit](#) specification please refer to the Software Component Template [3].

Class	HwAttributeDef			
Package	M2::AUTOSARTemplates::EcuResourceTemplate::HwElementCategory			
Note	This metaclass represents the ability to define a particular hardware attribute. The category of this element defines the type of the attributeValue. If the category is Enumeration the hwAttributeEnumerationLiterals specify the available literals.			
Base	ARObject, Identifiable , MultilanguageReferrable, Referrable			
Attribute	Datatype	Mul.	Kind	Note
hwAttributeLiteral	HwAttributeLiteralDef	*	aggr	The available EnumerationLiterals of the Enumeration definition. Only applicable if the category of the HwAttributeDef equals Enumeration.
isRequired	Boolean	1	attr	This attribute specifies if the defined attribute value is required to be provided.
unit	Unit	0..1	ref	This association specifies the physical unit of the defined hardware attribute. This is optional due to the fact that there are textual attributes.

Table 2.13: HwAttributeDef

In case the `category` of the `HwAttributeDef` is set to `Enumeration` the applicable enumeration literals are specified with the element `HwAttributeLiteralDef`.

Class	HwAttributeLiteralDef			
Package	M2::AUTOSARTemplates::EcuResourceTemplate::HwElementCategory			
Note	One available EnumerationLiteral of the Enumeration definition. Only applicable if the category of the HwAttributeDef equals Enumeration.			
Base	ARObject, Identifiable , MultilanguageReferrable, Referrable			
Attribute	Datatype	Mul.	Kind	Note
–	–	–	–	–

Table 2.14: HwAttributeLiteralDef

In example [A.8](#) the definition of some attributes for the `MemorySegment` category are described.

2.6.1 Vendor specific extensions of Hardware Category Definition

In order to allow the description of arbitrary hardware and their relationships the ECU Resource Template allows the extension of the definition of hardware categories and hardware attributes. When extending the ECU Resource Description for vendor specific usage the following rules shall be respected:

- **[TPS_ECUR_01021] Definition of new hardware categories** [New hardware categories for `HwElement` and `HwPinGroup` and `HwPin` can be defined if they are different from the categories defined in section 3. This definition shall be in a package which is not the `AUTOSAR` package. A `HwDescriptionEntity` shall then reference the extended hardware category.]

- **[TPS_ECUR_01022] Extension of existing hardware categories** [An existing hardware category from section 3 can be extended with new attribute definitions. The extension is via defining a hardware category of the same name as the standardized one in a different package than AUTOSAR. A `HwDescriptionEntity` shall then reference the standardized and the extended hardware category.]
- **[TPS_ECUR_01023] No redefinition of hardware attributes** [An extension of the standardized hardware category shall not define the same hardware attributes as already defined in the standardized hardware category.]
- **[TPS_ECUR_01024] Extension of enumeration** [An existing enumeration attribute from section 3 can be extended with new enumeration literals.]
- **[TPS_ECUR_01025] No removal of existing enumeration literals** [Enumeration literals shall not be removed from the specified enumeration attributes in section 3.]
- **[TPS_ECUR_01026] No change of category** [The category (type) of specified attributes in section 3 shall not be changed.]
- **[TPS_ECUR_01027] No change of `isRequired` value** [The value of the `isRequired` element shall not be changed for specified attributes in section 3.]
- **[TPS_ECUR_01028] No change of `Unit` value** [The value of the `Unit` element shall not be changed for specified attributes in section 3.]

2.7 Ecu Resource Variant Handling

For details on the AUTOSAR variant handling support please refer to the *AUTOSAR Generic Structure Template* [6]. The structure is shown in figure 2.1.

[TPS_ECUR_01029] Support for variant handling [In the description of a hardware element the following relationships are subject to variant handling:

- `nestedElement`
- `hwPinGroup`
- `hwElementConnection`

](*RS_ECUR_00015*)

The existence of a `HwPinGroup` can be variant via the aggregation role `hwPinGroup` from `HwElement`. So different alternatives of `HwPinGroup` can be specified. The content of the `HwPinGroup` can as well be variant via the roles `hwPinGroup` and `hwPin` from the `HwPinGroupContent`.

The existence of a `HwElementConnector` can be variant via the aggregation role `hwElementConnection` from `HwElement`. The existence of individual `HwPinGroupConnectors` and `HwPinConnectors` in several roles is as well subject to variability.

For the description of attribute values the existence of the [HwAttributeValue](#) and the actual `v` element are subject to variability (see also figure 2.2).

2.8 Documentation Support

AUTOSAR provides support for integrated and well structured documentation. More details about the AUTOSAR Documentation Support concept can be found in the AUTOSAR Generic Structure Template [6].

[TPS_ECUR_01030] Documentation support [An optional documentation block can be applied to any [Identifiable](#) and [Describable](#) element in an Ecu Resource Description. This type of documentation is typically used to capture a short introduction about the role of an element or respectively how it is built.] ([RS_ECUR_00017](#))

2.9 Infrastructural aspects

[TPS_ECUR_01032] Modeling of ECU Resource metamodel [The modeling of the ECU Configuration Value and ECU Configuration Parameter Definition metamodels is done according to the Generic Structure Template [6].] ([RS_ECUR_00012](#))

[TPS_ECUR_01033] Transformation of the ECU Resource metamodel to schema definition [The transformation of the ECU Resource metamodel to schema definitions is done according to the Model Persistence Rules for XML [4].] ([RS_ECUR_00013](#))

3 Hardware Type Specific Description

Chapter 2 introduced the general building blocks which are provided to describe hardware elements and their relationships. But in order to use the information from the ECU Resource Description to aid the configuration of an ECU there is need to describe dedicated attributes of specific hardware elements (e.g. memory size).

The following sections deal with the special elements that are necessary to specify a partly or complete engineered ECU with the ECU Resource Template.

3.1 HwElement categories

An overview of the applicable categories for `HwElement` is shown in table 3.1.

Category	Description
<code>Ecu</code>	Describes an Ecu (see section 3.1.1).
<code>ProcessingUnit</code>	Describes a micro-controller core (see section 3.1.2).
<code>MicroController</code>	Describes a micro-controller (see section 3.1.3).
<code>MemorySegment</code>	Describes a memory segment (see section 3.1.4).
<code>CommunicationController</code>	Describes a communication controller (see section 3.1.5).
<code>CommunicationTransceiver</code>	Describes a communication transceiver (see section 3.1.6).
<code>Digital</code>	Describes a digital IO peripheral (see section 3.1.7).
<code>Analog</code>	Describes an analog IO peripheral (see section 3.1.8).
<code>Timer</code>	Describes a timer peripheral (see section 3.1.9).
<code>Watchdog</code>	Describes a watchdog peripheral (see section 3.1.10).
<code>SensorActuator</code>	Describes sensors and actuators (see section 3.1.11).

Table 3.1: Hardware Element Categories

3.1.1 Ecu

[TPS_ECUR_01034] Category of an Ecu [The category of an ECU is defined as `Ecu`.]([RS_ECUR_00007](#))

Currently no special attributes are defined for the ECU.

3.1.2 Processing Unit

The processing unit describes one core of a micro-controller.

[TPS_ECUR_01007] Category of a processing unit [The category of a processing unit is defined as `ProcessingUnit`.]([RS_ECUR_00007](#))

Currently no special attributes are defined for the processing unit.

3.1.3 Micro-Controller

The micro-controller describes one piece of hardware as delivered by the manufacturer of the micro-controller hardware. Typically the micro-controller contains one or several processing units, memory segments and peripherals.

[TPS_ECUR_01035] Category of a micro-controller [The category of a micro-controller is defined as `MicroController`.]([RS_ECUR_00007](#))

Currently no special attributes are defined for the micro-controller.

Example [A.1](#) shows a simple description of a high-level view on a micro-controller.

3.1.4 Memory

[TPS_ECUR_01008] Attributes for the category `MemorySegment` [The special attributes which are applicable for the category `MemorySegment` hardware elements are defined in table [3.2](#).]([RS_ECUR_00008](#))

Attribute	Required	Type / Unit	Description
memorySize	true	INTEGER	Specifies the size of the memory segment in bytes.
memoryType	true	ENUMERATION	Specifies the type of memory: <ul style="list-style-type: none"> • RAM • ROM • EEPROM • Flash

Table 3.2: `MemorySegment` Hardware Element Attributes

3.1.5 Communication Controller

[TPS_ECUR_01009] Category of a communication controller [The category of a communication controller is `CommunicationController`.]([RS_ECUR_00009](#))

Attribute	Required	Type / Unit	Description
communication Controller Type	true	ENUMERATION	Specifies the type of communication controller: <ul style="list-style-type: none"> • CAN • TTCAN • LIN • FlexRay • Ethernet • Spi

Table 3.3: CommunicationController Hardware Element Attributes

3.1.6 Communication Transceiver

[TPS_ECUR_01010] Category of a communication transceiver [The category of a communication transceiver is defined as `CommunicationTransceiver`.]([RS_ECUR_00009](#))

Attribute	Required	Type / Unit	Description
supports Disabling	false	BOOLEAN	Specifies whether the transceiver can be disabled.
supports WakeUp	false	BOOLEAN	Specifies whether the transceiver can indicate a wake-up situation on the bus.

Table 3.4: CommunicationTransceiver Hardware Element Attributes

3.1.7 Digital IO

[TPS_ECUR_01011] Category of a digital IO [The category of a digital IO hardware element is defined as `Digital`.]([RS_ECUR_00010](#))

Currently no special attributes are defined for the digital IO.

3.1.8 Analog IO

[TPS_ECUR_01036] Category of an analog IO [The category of an analog IO hardware element is defined as `Analog`.]([RS_ECUR_00007](#))

Currently no special attributes are defined for the analog IO.

3.1.9 Timer

[TPS_ECUR_01037] Category of a timer [The category of a timer is defined as `Timer`.]([RS_ECUR_00007](#))

Currently no special attributes are defined for the timer.

3.1.10 Watchdog

[TPS_ECUR_01038] Category of a watchdog [The category of a watchdog is defined as `Watchdog`.]([RS_ECUR_00007](#))

Currently no special attributes are defined for the watchdog.

3.1.11 SensorActuator

[TPS_ECUR_01012] Category of a sensor/actuator [The category of a sensor/actuator is defined as `SensorActuator`.]([RS_ECUR_00011](#))

Currently no special attributes are defined for the sensor/actuator.

3.2 HwPinGroup categories

An overview of the applicable categories for `HwPinGroup` is shown in table 3.5.

Category	Description
<code>CommunicationPort</code>	Describes a communication connector (see section 3.2.1).

Table 3.5: Hardware Pin Group Categories

3.2.1 CommunicationPort

[TPS_ECUR_01013] Category of a Communication Port [The category of a Communication Port is defined as `CommunicationPort`.]([RS_ECUR_00009](#))

Attribute	Required	Type / Unit	Description
<code>communicationPortType</code>	true	ENUMERATION	Specifies the type of communication port: <ul style="list-style-type: none"> • CAN • TTCAN • LIN • FlexRay • Ethernet • Spi

Table 3.6: CommunicationPort Hardware Element Attributes

3.3 HwPin categories

There are no dedicated categories specified for `HwPin`.

A Examples

A.1 Hardware Element

Example [A.1](#) shows a simple description of a high-level view on a micro-controller.

Example A.1

```
<AR-PACKAGE>
  <SHORT-NAME>VendorA</SHORT-NAME>
  <ELEMENTS>
    <HW-ELEMENT>
      <SHORT-NAME>MicroController_0815</SHORT-NAME>
      <HW-CATEGORY-REFS>
        <HW-CATEGORY-REF DEST="HW-CATEGORY"/>/AUTOSAR/MicroController</HW-
          CATEGORY-REF>
      </HW-CATEGORY-REFS>
    </HW-ELEMENT>
  </ELEMENTS>
</AR-PACKAGE>
```

A.2 Hierarchy of Hardware Elements

Example [A.2](#) shows the hierarchical description of a processing unit in a micro-controller.

Example A.2

```
<AR-PACKAGE>
  <SHORT-NAME>VendorA</SHORT-NAME>
  <ELEMENTS>
    <HW-ELEMENT>
      <SHORT-NAME>MicroController_0815</SHORT-NAME>
      <HW-CATEGORY-REFS>
        <HW-CATEGORY-REF DEST="HW-CATEGORY"/>/AUTOSAR/MicroController</HW-
          CATEGORY-REF>
      </HW-CATEGORY-REFS>
      <NESTED-ELEMENTS>
        <HW-ELEMENT-REF-CONDITIONAL>
          <HW-ELEMENT-REF DEST="HW-ELEMENT"/>/VendorA/ProcessingUnit0</HW-
            ELEMENT-REF>
        </HW-ELEMENT-REF-CONDITIONAL>
      </NESTED-ELEMENTS>
    </HW-ELEMENT>
    <HW-ELEMENT>
      <SHORT-NAME>ProcessingUnit0</SHORT-NAME>
      <HW-CATEGORY-REFS>
        <HW-CATEGORY-REF DEST="HW-CATEGORY"/>/AUTOSAR/ProcessingUnit</HW-
          CATEGORY-REF>
      </HW-CATEGORY-REFS>
    </HW-ELEMENT>
```

```
</ELEMENTS>
</AR-PACKAGE>
```

A.3 HwPinGroups and HwPins

Example A.3 shows the description of pin groups and pins of the micro-controller.

Example A.3

```
<AR-PACKAGE>
  <SHORT-NAME>VendorA</SHORT-NAME>
  <ELEMENTS>
    <HW-ELEMENT>
      <SHORT-NAME>MicroController_0815</SHORT-NAME>
      <HW-CATEGORY-REFS>
        <HW-CATEGORY-REF DEST="HW-CATEGORY"/>/AUTOSAR/MicroController</HW-
          CATEGORY-REF>
      </HW-CATEGORY-REFS>
      <HW-PIN-GROUPS>
        <HW-PIN-GROUP>
          <SHORT-NAME>Adc</SHORT-NAME>
          <HW-PIN-GROUP-CONTENT>
            <HW-PIN-GROUP>
              <SHORT-NAME>AdcPortA</SHORT-NAME>
            </HW-PIN-GROUP>
            <HW-PIN-GROUP>
              <SHORT-NAME>AdcPortB</SHORT-NAME>
              <HW-PIN-GROUP-CONTENT>
                <HW-PIN>
                  <SHORT-NAME>AdcB01</SHORT-NAME>
                </HW-PIN>
                <HW-PIN>
                  <SHORT-NAME>AdcB02</SHORT-NAME>
                </HW-PIN>
              </HW-PIN-GROUP-CONTENT>
            </HW-PIN-GROUP>
          </HW-PIN-GROUP-CONTENT>
        </HW-PIN-GROUP>
      </HW-PIN-GROUPS>
    </HW-ELEMENT>
  </ELEMENTS>
</AR-PACKAGE>
```

A.4 Hardware Element Connection

Example A.4 shows the description of the internal structure of a micro-controller in order to define which memory segments are accessible from which processing unit (core).

Example A.4

```

<AR-PACKAGE>
  <SHORT-NAME>VendorA</SHORT-NAME>
  <ELEMENTS>
    <HW-ELEMENT>
      <SHORT-NAME>MicroController_0815</SHORT-NAME>
      <HW-CATEGORY-REFS>
        <HW-CATEGORY-REF DEST="HW-CATEGORY"/>/AUTOSAR/MicroController</HW-
          CATEGORY-REF>
      </HW-CATEGORY-REFS>
      <NESTED-ELEMENTS>
        <HW-ELEMENT-REF-CONDITIONAL>
          <HW-ELEMENT-REF DEST="HW-ELEMENT"/>/VendorA/Core0</HW-ELEMENT-REF>
        </HW-ELEMENT-REF-CONDITIONAL>
        <HW-ELEMENT-REF-CONDITIONAL>
          <HW-ELEMENT-REF DEST="HW-ELEMENT"/>/VendorA/Core1</HW-ELEMENT-REF>
        </HW-ELEMENT-REF-CONDITIONAL>
        <HW-ELEMENT-REF-CONDITIONAL>
          <HW-ELEMENT-REF DEST="HW-ELEMENT"/>/VendorA/Mem01</HW-ELEMENT-REF>
        </HW-ELEMENT-REF-CONDITIONAL>
        <!-- ... -->
      </NESTED-ELEMENTS>
      <HW-ELEMENT-CONNECTIONS>
        <HW-ELEMENT-CONNECTOR>
          <HW-ELEMENT-REFS>
            <HW-ELEMENT-REF DEST="HW-ELEMENT"/>/VendorA/Core0</HW-ELEMENT-
              REF>
            <HW-ELEMENT-REF DEST="HW-ELEMENT"/>/VendorA/Mem01</HW-ELEMENT-
              REF>
          </HW-ELEMENT-REFS>
        </HW-ELEMENT-CONNECTOR>
        <HW-ELEMENT-CONNECTOR>
          <HW-ELEMENT-REFS>
            <HW-ELEMENT-REF DEST="HW-ELEMENT"/>/VendorA/Core0</HW-ELEMENT-
              REF>
            <HW-ELEMENT-REF DEST="HW-ELEMENT"/>/VendorA/Mem02</HW-ELEMENT-
              REF>
          </HW-ELEMENT-REFS>
        </HW-ELEMENT-CONNECTOR>
        <!-- .. -->
      </HW-ELEMENT-CONNECTIONS>
    </HW-ELEMENT>
    <HW-ELEMENT>
      <SHORT-NAME>Core0</SHORT-NAME>
      <HW-CATEGORY-REFS>
        <HW-CATEGORY-REF DEST="HW-CATEGORY"/>/AUTOSAR/ProcessingUnit</HW-
          CATEGORY-REF>
      </HW-CATEGORY-REFS>
  
```

```

</HW-ELEMENT>
<HW-ELEMENT>
  <SHORT-NAME>Core1</SHORT-NAME>
  <HW-CATEGORY-REFS>
    <HW-CATEGORY-REF DEST="HW-CATEGORY"/>/AUTOSAR/ProcessingUnit</HW-
      CATEGORY-REF>
  </HW-CATEGORY-REFS>
</HW-ELEMENT>
<HW-ELEMENT>
  <SHORT-NAME>Mem01</SHORT-NAME>
  <HW-CATEGORY-REFS>
    <HW-CATEGORY-REF DEST="HW-CATEGORY"/>/AUTOSAR/MemorySegment</HW-
      CATEGORY-REF>
  </HW-CATEGORY-REFS>
</HW-ELEMENT>
<HW-ELEMENT>
  <SHORT-NAME>Mem02</SHORT-NAME>
  <HW-CATEGORY-REFS>
    <HW-CATEGORY-REF DEST="HW-CATEGORY"/>/AUTOSAR/MemorySegment</HW-
      CATEGORY-REF>
  </HW-CATEGORY-REFS>
</HW-ELEMENT>
<HW-ELEMENT>
  <SHORT-NAME>Mem03</SHORT-NAME>
  <HW-CATEGORY-REFS>
    <HW-CATEGORY-REF DEST="HW-CATEGORY"/>/AUTOSAR/MemorySegment</HW-
      CATEGORY-REF>
  </HW-CATEGORY-REFS>
</HW-ELEMENT>
</ELEMENTS>
</AR-PACKAGE>

```

A.5 Combined Example

In this example section several mechanisms are utilized to describe an Ecu and some of its electronics attributes. The overview is shown in figure [A.1](#). The individual sections describe the different abstraction layers.

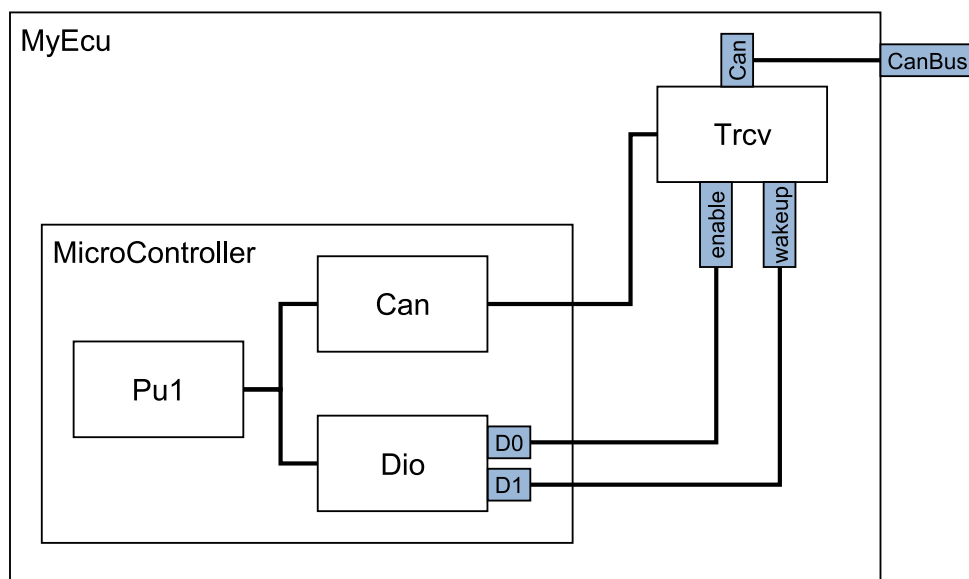

Figure A.1: Example of Ecu description

A.5.1 Micro-controller description

The micro-controller consists of the processing unit, a Can controller and a Dio module. The processing unit is defined to have access to both of the peripherals.

The Dio module defines two [HwPinGroups](#) in order to support more detailed connection description.

The whole micro-controller is defined in an own [ARPackage](#) so it can be used in several projects.

Example A.5

```
<AR-PACKAGE>
  <SHORT-NAME>CpuVendor</SHORT-NAME>
  <ELEMENTS>
    <HW-ELEMENT>
      <SHORT-NAME>MicroController</SHORT-NAME>
      <NESTED-ELEMENTS>
        <HW-ELEMENT-REF-CONDITIONAL>
          <HW-ELEMENT-REF
            DEST="HW-ELEMENT">Pu1</HW-ELEMENT-REF>
          </HW-ELEMENT-REF-CONDITIONAL>
        <HW-ELEMENT-REF-CONDITIONAL>
          <HW-ELEMENT-REF
            DEST="HW-ELEMENT">Can</HW-ELEMENT-REF>
          </HW-ELEMENT-REF-CONDITIONAL>
        <HW-ELEMENT-REF-CONDITIONAL>
          <HW-ELEMENT-REF
            DEST="HW-ELEMENT">Dio</HW-ELEMENT-REF>
          </HW-ELEMENT-REF-CONDITIONAL>
        </NESTED-ELEMENTS>
      </HW-ELEMENT>
    </ELEMENTS>
  </AR-PACKAGE>
```



```

<HW-ELEMENT-CONNECTIONS>
  <HW-ELEMENT-CONNECTOR>
    <HW-ELEMENT-REFS>
      <HW-ELEMENT-REF
        DEST="HW-ELEMENT">Pul</HW-ELEMENT-REF>
      <HW-ELEMENT-REF
        DEST="HW-ELEMENT">Can</HW-ELEMENT-REF>
    </HW-ELEMENT-REFS>
  </HW-ELEMENT-CONNECTOR>
  <HW-ELEMENT-CONNECTOR>
    <HW-ELEMENT-REFS>
      <HW-ELEMENT-REF
        DEST="HW-ELEMENT">Pul</HW-ELEMENT-REF>
      <HW-ELEMENT-REF
        DEST="HW-ELEMENT">Dio</HW-ELEMENT-REF>
    </HW-ELEMENT-REFS>
  </HW-ELEMENT-CONNECTOR>
</HW-ELEMENT-CONNECTIONS>
</HW-ELEMENT>
<HW-ELEMENT>
  <SHORT-NAME>Pul</SHORT-NAME>
</HW-ELEMENT>
<HW-ELEMENT>
  <SHORT-NAME>Can</SHORT-NAME>
</HW-ELEMENT>
<HW-ELEMENT>
  <SHORT-NAME>Dio</SHORT-NAME>
<HW-PIN-GROUPS>
  <HW-PIN-GROUP>
    <SHORT-NAME>D0</SHORT-NAME>
  </HW-PIN-GROUP>
  <HW-PIN-GROUP>
    <SHORT-NAME>D1</SHORT-NAME>
  </HW-PIN-GROUP>
</HW-PIN-GROUPS>
</HW-ELEMENT>
</ELEMENTS>
</AR-PACKAGE>

```

A.5.2 Transceiver description

The transceiver module is defined as a `HwElement` which provides three `HwPinGroups` to describe its connectivity.

The transceiver module is defined in an own `ARPackage` so it can be used in several projects.

Example A.6

```

<AR-PACKAGE>
  <SHORT-NAME>TransceiverVendor</SHORT-NAME>
  <ELEMENTS>

```

```

<HW-ELEMENT>
  <SHORT-NAME>Trcv</SHORT-NAME>
  <HW-PIN-GROUPS>
    <HW-PIN-GROUP>
      <SHORT-NAME>enable</SHORT-NAME>
    </HW-PIN-GROUP>
    <HW-PIN-GROUP>
      <SHORT-NAME>wakeUp</SHORT-NAME>
    </HW-PIN-GROUP>
    <HW-PIN-GROUP>
      <SHORT-NAME>CanBus</SHORT-NAME>
    </HW-PIN-GROUP>
  </HW-PIN-GROUPS>
</HW-ELEMENT>
</ELEMENTS>
</AR-PACKAGE>

```

A.5.3 Ecu description

The Ecu contains the micro-controller and the transceiver.

The Ecu defines one [HwPinGroup](#) to represent the CanBus communication to the outside of the Ecu.

The Ecu defines the detailed connectivity inside.

Example A.7

```

<AR-PACKAGE>
  <SHORT-NAME>EcuVendor</SHORT-NAME>
  <ELEMENTS>
    <HW-ELEMENT>
      <SHORT-NAME>MyEcu</SHORT-NAME>
      <NESTED-ELEMENTS>
        <HW-ELEMENT-REF-CONDITIONAL>
          <HW-ELEMENT-REF
            DEST="HW-ELEMENT"/>CpuVendor/MicroController</HW-ELEMENT-REF>
        </HW-ELEMENT-REF-CONDITIONAL>
        <HW-ELEMENT-REF-CONDITIONAL>
          <HW-ELEMENT-REF
            DEST="HW-ELEMENT"/>TransceiverVendor/Trcv</HW-ELEMENT-REF>
        </HW-ELEMENT-REF-CONDITIONAL>
      </NESTED-ELEMENTS>
      <HW-PIN-GROUPS>
        <HW-PIN-GROUP>
          <SHORT-NAME>CanBus</SHORT-NAME>
        </HW-PIN-GROUP>
      </HW-PIN-GROUPS>
      <HW-ELEMENT-CONNECTIONS>
        <HW-ELEMENT-CONNECTOR>
          <HW-ELEMENT-REFS>
            <HW-ELEMENT-REF

```

```

    DEST="HW-ELEMENT"/>CpuVendor/Can</HW-ELEMENT-REF>
  <HW-ELEMENT-REF
    DEST="HW-ELEMENT"/>TransceiverVendor/Trcv</HW-ELEMENT-REF>
</HW-ELEMENT-REFS>
</HW-ELEMENT-CONNECTOR>
<HW-ELEMENT-CONNECTOR>
  <HW-ELEMENT-REFS>
    <HW-ELEMENT-REF
      DEST="HW-ELEMENT"/>CpuVendor/Dio</HW-ELEMENT-REF>
    <HW-ELEMENT-REF
      DEST="HW-ELEMENT"/>TransceiverVendor/Trcv</HW-ELEMENT-REF>
  </HW-ELEMENT-REFS>
<HW-PIN-GROUP-CONNECTIONS>
  <HW-PIN-GROUP-CONNECTOR>
    <HW-PIN-GROUP-REFS>
      <HW-PIN-GROUP-REF DEST="HW-PIN-GROUP"/>CpuVendor/Dio/D0</HW-
        PIN-GROUP-REF>
      <HW-PIN-GROUP-REF DEST="HW-PIN-GROUP"/>TransceiverVendor/
        Trcv/enable</HW-PIN-GROUP-REF>
    </HW-PIN-GROUP-REFS>
  </HW-PIN-GROUP-CONNECTOR>
  <HW-PIN-GROUP-CONNECTOR>
    <HW-PIN-GROUP-REFS>
      <HW-PIN-GROUP-REF DEST="HW-PIN-GROUP"/>CpuVendor/Dio/D1</HW-
        PIN-GROUP-REF>
      <HW-PIN-GROUP-REF DEST="HW-PIN-GROUP"/>TransceiverVendor/
        Trcv/wakeup</HW-PIN-GROUP-REF>
    </HW-PIN-GROUP-REFS>
  </HW-PIN-GROUP-CONNECTOR>
</HW-PIN-GROUP-CONNECTIONS>
</HW-ELEMENT-CONNECTOR>
<HW-ELEMENT-CONNECTOR>
  <HW-ELEMENT-REFS>
    <HW-ELEMENT-REF
      DEST="HW-ELEMENT"/>TransceiverVendor/Trcv</HW-ELEMENT-REF>
    <HW-ELEMENT-REF
      DEST="HW-ELEMENT"/>EcuVendor/MyEcu</HW-ELEMENT-REF>
  </HW-ELEMENT-REFS>
<HW-PIN-GROUP-CONNECTIONS>
  <HW-PIN-GROUP-CONNECTOR>
    <HW-PIN-GROUP-REFS>
      <HW-PIN-GROUP-REF
        DEST="HW-PIN-GROUP"/>TransceiverVendor/Trcv/Can</HW-PIN-
          GROUP-REF>
      <HW-PIN-GROUP-REF
        DEST="HW-PIN-GROUP"/>EcuVendor/CanBus</HW-PIN-GROUP-REF>
    </HW-PIN-GROUP-REFS>
  </HW-PIN-GROUP-CONNECTOR>
</HW-PIN-GROUP-CONNECTIONS>
</HW-ELEMENT-CONNECTOR>
</HW-ELEMENT-CONNECTIONS>
</HW-ELEMENT>
</ELEMENTS>
</AR-PACKAGE>

```

A.6 Attribute Definition

Example A.8 shows how a category and associated attribute definitions are described in the ECU Resource Template.

Example A.8

```

<AR-PACKAGE>
  <SHORT-NAME>AUTOSAR</SHORT-NAME>
  <ELEMENTS>
    <HW-CATEGORY>
      <SHORT-NAME>MemorySegment</SHORT-NAME>
      <HW-ATTRIBUTE-DEFS>
        <HW-ATTRIBUTE-DEF>
          <SHORT-NAME>memorySize</SHORT-NAME>
          <DESC>
            <L-2 L="EN">Specifies the size of the memory segment in
              bytes.</L-2>
          </DESC>
          <CATEGORY>INTEGER</CATEGORY>
          <IS-REQUIRED>true</IS-REQUIRED>
        </HW-ATTRIBUTE-DEF>
        <HW-ATTRIBUTE-DEF>
          <SHORT-NAME>memoryType</SHORT-NAME>
          <DESC>
            <L-2 L="EN">Specifies the type of memory: RAM, ROM, EEPROM,
              Flash.</L-2>
          </DESC>
          <CATEGORY>ENUMERATION</CATEGORY>
          <HW-ATTRIBUTE-LITERALS>
            <HW-ATTRIBUTE-LITERAL-DEF><SHORT-NAME>RAM</SHORT-NAME></HW-
              ATTRIBUTE-LITERAL-DEF>
            <HW-ATTRIBUTE-LITERAL-DEF><SHORT-NAME>ROM</SHORT-NAME></HW-
              ATTRIBUTE-LITERAL-DEF>
            <HW-ATTRIBUTE-LITERAL-DEF><SHORT-NAME>FLASH</SHORT-NAME></
              HW-ATTRIBUTE-LITERAL-DEF>
            <HW-ATTRIBUTE-LITERAL-DEF><SHORT-NAME>EEPROM</SHORT-NAME></
              HW-ATTRIBUTE-LITERAL-DEF>
          </HW-ATTRIBUTE-LITERALS>
          <IS-REQUIRED>true</IS-REQUIRED>
        </HW-ATTRIBUTE-DEF>
      </HW-ATTRIBUTE-DEFS>
    </HW-CATEGORY>
  </ELEMENTS>
</AR-PACKAGE>

```

A.7 Attribute Value Example

Example A.9 shows the description of attributes which have been defined using the ECU Resource Template (see example A.8).

Example A.9

```
<AR-PACKAGE>
  <SHORT-NAME>VendorA</SHORT-NAME>
  <ELEMENTS>
    <HW-ELEMENT>
      <SHORT-NAME>MemorySeg001</SHORT-NAME>
      <HW-CATEGORY-REFS>
        <HW-CATEGORY-REF DEST="HW-CATEGORY">/AUTOSAR/MemorySegment</HW-
          CATEGORY-REF>
      </HW-CATEGORY-REFS>
      <HW-ATTRIBUTE-VALUES>
        <HW-ATTRIBUTE-VALUE>
          <HW-ATTRIBUTE-DEF-REF DEST="HW-ATTRIBUTE-DEF">/AUTOSAR/
            MemorySegment/memoryType</HW-ATTRIBUTE-DEF-REF>
          <VT>RAM</VT>
        </HW-ATTRIBUTE-VALUE>
        <HW-ATTRIBUTE-VALUE>
          <HW-ATTRIBUTE-DEF-REF DEST="HW-ATTRIBUTE-DEF">/AUTOSAR/
            MemorySegment/memorySize</HW-ATTRIBUTE-DEF-REF>
          <V>1024</V>
        </HW-ATTRIBUTE-VALUE>
      </HW-ATTRIBUTE-VALUES>
    </HW-ELEMENT>
  </ELEMENTS>
</AR-PACKAGE>
```

B Glossary

Artifact This is a Work Product Definition that provides a description and definition for tangible work product types. Artifacts may be composed of other artifacts ([8]).

At a high level, an artifact is represented as a single conceptual file.

AUTOSAR Tool This is a software tool which supports one or more tasks defined as AUTOSAR tasks in the methodology. Depending on the supported tasks, an AUTOSAR tool can act as an authoring tool, a converter tool, a processor tool or as a combination of those (see separate definitions).

AUTOSAR Authoring Tool An AUTOSAR Tool used to create and modify AUTOSAR XML Descriptions. Example: System Description Editor.

AUTOSAR Converter Tool An AUTOSAR Tool used to create AUTOSAR XML files by converting information from other AUTOSAR XML files. Example: ECU Flattener

AUTOSAR Definition This is the definition of parameters which can have values. One could say that the parameter values are Instances of the definitions. But in the meta model hierarchy of AUTOSAR, definitions are also instances of the meta model and therefore considered as a description. Examples for AUTOSAR definitions are: `EcucParameterDef`, `PostBuildVariantCriterion`, `SwSystemconst`.

AUTOSAR XML Description In AUTOSAR this means "filled Template". In fact an AUTOSAR XML description is the XML representation of an AUTOSAR model.

The AUTOSAR XML description can consist of several files. Each individual file represents an AUTOSAR partial model and shall validate successfully against the AUTOSAR XML schema.

AUTOSAR Meta-Model This is an UML2.0 model that defines the language for describing AUTOSAR systems. The AUTOSAR meta-model is an UML representation of the AUTOSAR templates. UML2.0 class diagrams are used to describe the attributes and their interrelationships. Stereotypes, UML tags and OCL expressions (object constraint language) are used for defining specific semantics and constraints.

AUTOSAR Model This is a representation of an AUTOSAR product. The AUTOSAR model represents aspects suitable to the intended use according to the AUTOSAR methodology.

Strictly speaking, this is an instance of the AUTOSAR meta-model. The information contained in the AUTOSAR model can be anything that is representable according to the AUTOSAR meta-model.

AUTOSAR Partial Model In AUTOSAR, the possible partitioning of models is marked in the meta-model by `<<atpSplittable>>`. One partial model is represented in an AUTOSAR XML description by one file. The partial model does not need to fulfill all semantic constraints applicable to an AUTOSAR model.

AUTOSAR Processor Tool An AUTOSAR Tool used to create non-AUTOSAR files by processing information from AUTOSAR XML files. Example: RTE Generator

AUTOSAR Template The term "Template" is used in AUTOSAR to describe the format different kinds of descriptions. The term template comes from the idea, that AUTOSAR defines a kind of form which shall be filled out in order to describe a model. The filled form is then called the description.

In fact the AUTOSAR templates are now defined as a meta model.

AUTOSAR XML Schema This is a W3C XML schema that defines the language for exchanging AUTOSAR models. This Schema is derived from the AUTOSAR meta model. The AUTOSAR XML Schema defines the AUTOSAR data exchange format.

Blueprint This is a model from which other models can be derived by copy and refinement. Note that in contrast to meta model resp. types, this process is *not* an instantiation.

Instance Generally this is a particular exemplar of a model or of a type.

Life Cycle Life Cycle is the course of development/evolutionary stages of a model element during its life time.

Meta-Model This defines the building blocks of a model. In that sense, a Meta-Model represents the language for building models.

Meta-Data This includes pertinent information about data, including information about the authorship, versioning, access-rights, timestamps etc.

Model A Model is an simplified representation of reality. The model represents the aspects suitable for an intended purpose.

Partial Model This is a part of a model which is intended to be persisted in one particular artifact.

Pattern in GST : This is an approach to simplify the definition of the meta model by applying a model transformation. This transformation creates an enhanced model out of an annotated model.

Property A property is a structural feature of an object. As an example a "connector" has the properties "receive port" and "send port"

Properties are made variant by the `<<atpVariation>>`.

Prototype This is the implementation of a role of a type within the definition of another type. In other words a type may contain Prototypes that in turn are typed by "Types". Each one of these prototypes becomes an instance when this type is instantiated.

Type A type provides features that can appear in various roles of this type.

Value This is a particular value assigned to a "Definition".

Variability Variability of a system is its quality to describe a set of variants. These variants are characterized by variant specific property settings and / or selections. As an example, such a system property selection manifests itself in a particular “receive port” for a connection.

This is implemented using the `<<atpVariation>>`.

Variant A system variant is a concrete realization of a system, so that all its properties have been set respectively selected. The software system has no variability anymore with respect to the binding time.

This is implemented using `EvaluatedVariantSet`.

Variation Binding A variant is the result of a variation binding process that resolves the variability of the system by assigning particular values/selections to all the system’s properties.

This is implemented by `VariationPoint`.

Variation Binding Time The variation binding time determines the step in the methodology at which the variability given by a set of variable properties is resolved.

This is implemented by `vh.LatestBindingtime` at the related properties .

Variation Definition Time The variation definition time determines the step in the methodology at which the variation points are defined.

Variation Point A variation point indicates that a property is subject to variation. Furthermore, it is associated with a condition and a binding time which define the system context for the selection / setting of a concrete variant.

This is implemented by `VariationPoint`.

C Change History

C.1 Change History between AUTOSAR R4.0.1 against R3.1.5

The document and the MetaModel have been revised completely.

C.2 Change History between AUTOSAR R4.0.2 against R4.0.1

No changes to specification items.

C.3 Change History between AUTOSAR R4.0.3 against R4.0.2

C.3.1 Added Constraints in R4.0.3

Number	Heading
[constr_3500]	category of HwAttributeDef shall not be extended

Table C.1: Added Constraints in R4.0.3

C.4 Change History between AUTOSAR R4.1.1 against R4.0.3

C.4.1 Added Constraints in R4.1.1

Number	Heading
[constr_3511]	HwType shall not have a reference to another HwType
[constr_3512]	No support of multiple instantiation
[constr_3513]	Scope of connections

Table C.2: Added Constraints in R4.1.1

C.4.2 Added SWS Items in R4.1.1

SWS Item	Rationale
[TPS_ECUR_01000]	Definition of HwCategory
[TPS_ECUR_01001]	Extension of HwCategory
[TPS_ECUR_01002]	Definition of Hardware Elements
[TPS_ECUR_01003]	Values of hardware attributes
[TPS_ECUR_01005]	The HwElement describes one piece of hardware
[TPS_ECUR_01006]	Connections between HwElements
[TPS_ECUR_01007]	The category of a processing unit is defined as ProcessingUnit .
[TPS_ECUR_01008]	The special attributes which are applicable for the category MemorySegment hardware elements are defined in table 3.2.
[TPS_ECUR_01009]	The category of a communication controller is CommunicationController .

[TPS_ECUR_01010]	The category of a communication transceiver is defined as <code>CommunicationTransceiver</code> .
[TPS_ECUR_01011]	The category of a digital IO hardware element is defined as <code>Digital</code> .
[TPS_ECUR_01012]	The category of a sensor/actuator is defined as <code>SensorActuator</code> .
[TPS_ECUR_01013]	The category of a Communication Port is defined as <code>CommunicationPort</code> .
[TPS_ECUR_01014]	Definition of <code>HwAttributeValue</code>
[TPS_ECUR_01015]	Support of AUTOSAR Basic Software configuration
[TPS_ECUR_01016]	Definition of <code>HwType</code>
[TPS_ECUR_01017]	Attribute values defined in the <code>HwType</code> are applicable for all occurrences of this <code>HwType</code>
[TPS_ECUR_01018]	<code>HwElement</code> is self contained
[TPS_ECUR_01019]	<code>HwElement</code> can refer to a <code>HwType</code>
[TPS_ECUR_01020]	Hierarchy of hardware
[TPS_ECUR_01021]	Definition of new hardware categories
[TPS_ECUR_01022]	Extension of existing hardware categories
[TPS_ECUR_01023]	No redefinition of hardware attributes
[TPS_ECUR_01024]	Extension of enumeration
[TPS_ECUR_01025]	No removal of existing enumeration literals
[TPS_ECUR_01026]	No change of category
[TPS_ECUR_01027]	No change of <code>isRequired</code> value
[TPS_ECUR_01028]	No change of <code>Unit</code> value
[TPS_ECUR_01029]	Support for variant handling
[TPS_ECUR_01030]	Documentation support
[TPS_ECUR_01031]	Definition of attribute unit
[TPS_ECUR_01032]	Modeling of ECU Resource metamodel
[TPS_ECUR_01033]	Transformation of the ECU Resource metamodel to schema definition
[TPS_ECUR_01034]	Category of an Ecu
[TPS_ECUR_01035]	Category of a micro-controller
[TPS_ECUR_01036]	Category of an analog IO
[TPS_ECUR_01037]	Category of a timer
[TPS_ECUR_01038]	Category of a watchdog

Table C.3: Added SWS Items in R4.1.1

D Mentioned Class Tables

For the sake of completeness, this chapter contains a set of class tables representing meta-classes mentioned in the context of this document but which are not contained directly in the scope of describing specific meta-model semantics.

Class	ARElement (abstract)			
Package	M2::AUTOSARTemplates::GenericStructure::GeneralTemplateClasses::ARPackage			
Note	An element that can be defined stand-alone, i.e. without being part of another element (except for packages of course).			
Base	ARObject,CollectableElement,Identifiable,MultilanguageReferrable,PackageableElement,Referrable			
Attribute	Datatype	Mul.	Kind	Note
–	–	–	–	–

Table D.1: ARElement

Class	ARPackage			
Package	M2::AUTOSARTemplates::GenericStructure::GeneralTemplateClasses::ARPackage			
Note	AUTOSAR package, allowing to create top level packages to structure the contained ARElements. ARPackages are open sets. This means that in a file based description system multiple files can be used to partially describe the contents of a package. This is an extended version of MSR's SW-SYSTEM.			
Base	ARObject,AtpBlueprint,AtpBlueprintable,CollectableElement,Identifiable,MultilanguageReferrable,Referrable			
Attribute	Datatype	Mul.	Kind	Note
arPackage	ARPackage	*	aggr	This represents a sub package within an ARPackage, thus allowing for an unlimited package hierarchy. Stereotypes: atpSplittable; atpVariation Tags: atp.Splitkey=shortName, variationPoint.shortLabel vh.latestBindingTime=blueprintDerivationTime xml.sequenceOffset=30
element	PackageableElement	*	aggr	Elements that are part of this package Stereotypes: atpSplittable; atpVariation Tags: atp.Splitkey=shortName, variationPoint.shortLabel vh.latestBindingTime=systemDesignTime xml.sequenceOffset=20

Attribute	Datatype	Mul.	Kind	Note
referenceBase	ReferenceBase	*	aggr	This denotes the reference bases for the package. This is the basis for all relative references within the package. The base needs to be selected according to the base attribute within the references. Stereotypes: atpSplitable Tags: atp.splitkey=shortLabel xml.sequenceOffset=10

Table D.2: ARPackage

Class	AUTOSAR			
Package	M2::AUTOSARTemplates::AutosarTopLevelStructure			
Note	Root element of an AUTOSAR description, also the root element in corresponding XML documents. Tags: xml.globalElement=true			
Base	ARObject			
Attribute	Datatype	Mul.	Kind	Note
adminData	AdminData	0..1	aggr	This represents the administrative data of an Autosar file. Tags: xml.sequenceOffset=10
arPackage	ARPackage	*	aggr	This is the top level package in an AUTOSAR model. Stereotypes: atpSplitable; atpVariation Tags: atp.Splitkey=shortName, variationPoint.shortLabel vh.latestBindingTime=blueprintDerivationTime xml.sequenceOffset=30
introduction	Documentation Block	0..1	aggr	This represents an introduction on the Autosar file. It is intended for example to represent disclaimers and legal notes. Tags: xml.sequenceOffset=20

Table D.3: AUTOSAR

Class	Describable (abstract)			
Package	M2::AUTOSARTemplates::GenericStructure::GeneralTemplateClasses::Identifiable			
Note	This meta-class represents the ability to add a descriptive documentation to non identifiable elements.			
Base	ARObject			
Attribute	Datatype	Mul.	Kind	Note

Attribute	Datatype	Mul.	Kind	Note
desc	MultiLanguageOverviewParagraph	0..1	aggr	<p>This represents a general but brief (one paragraph) description what the object in question is about. It is only one paragraph! Desc is intended to be collected into overview tables. This property helps a human reader to identify the object in question.</p> <p>More elaborate documentation, (in particular how the object is built or used) should go to "introduction".</p> <p>Tags: xml.sequenceOffset=-60</p>
category	CategoryString	0..1	attr	<p>This element assigns a category to the parent element. The category is intended to specialize the usage and/or the content identifiable object. Such a specialization may also impose particular semantic constraints on the entire substructure (not only the identifiable itself).</p> <p>Tags: xml.sequenceOffset=-50</p>
adminData	AdminData	0..1	aggr	<p>This represents the administrative data for the describable object.</p> <p>Tags: xml.sequenceOffset=-20</p>
introduction	DocumentationBlock	0..1	aggr	<p>This represents more information about how the object in question is built or is used. Therefore it is a DocumentationBlock.</p> <p>Tags: xml.sequenceOffset=-30</p>

Table D.4: Describable

Class	Identifiable (abstract)			
Package	M2::AUTOSARTemplates::GenericStructure::GeneralTemplateClasses::Identifiable			
Note	Instances of this class can be referred to by their identifier (within the namespace borders). In addition to this, Identifiables are objects which contribute significantly to the overall structure of an AUTOSAR description. In particular, Identifiables might contain Identifiables.			
Base	ARObject, MultilanguageReferrable, Referrable			
Attribute	Datatype	Mul.	Kind	Note
desc	MultiLanguageOverviewParagraph	0..1	aggr	<p>This represents a general but brief (one paragraph) description what the object in question is about. It is only one paragraph! Desc is intended to be collected into overview tables. This property helps a human reader to identify the object in question.</p> <p>More elaborate documentation, (in particular how the object is built or used) should go to "introduction".</p> <p>Tags: xml.sequenceOffset=-60</p>

Attribute	Datatype	Mul.	Kind	Note
category	CategoryString	0..1	attr	<p>This element assigns a category to the parent element. The category is intended to specialize the usage and/or the content identifiable object. Such a specialization may also impose particular semantic constraints on the entire substructure (not only the identifiable itself).</p> <p>Tags: xml.sequenceOffset=-50</p>
adminData	AdminData	0..1	aggr	<p>This represents the administrative data for the identifiable object.</p> <p>Tags: xml.sequenceOffset=-40</p>
annotation	Annotation	*	aggr	<p>Possibility to provide additional notes while defining a model element (e.g. the ECU Configuration Parameter Values). These are not intended as documentation but are mere design notes.</p> <p>Tags: xml.sequenceOffset=-25</p>
introduction	Documentation Block	0..1	aggr	<p>This represents more information about how the object in question is built or is used. Therefore it is a DocumentationBlock.</p> <p>Tags: xml.sequenceOffset=-30</p>
uuid	String	0..1	attr	<p>The purpose of this attribute is to provide a globally unique identifier for an instance of a meta-class. The values of this attribute should be globally unique strings prefixed by the type of identifier. For example, to include a DCE UUID as defined by The Open Group, the UUID would be preceded by "DCE:". The values of this attribute may be used to support merging of different AUTOSAR models. The form of the UUID (Universally Unique Identifier) is taken from a standard defined by the Open Group (was Open Software Foundation). This standard is widely used, including by Microsoft for COM (GUIDs) and by many companies for DCE, which is based on CORBA. The method for generating these 128-bit IDs is published in the standard and the effectiveness and uniqueness of the IDs is not in practice disputed. If the id namespace is omitted, DCE is assumed. An example is "DCE:2fac1234-31f8-11b4-a222-08002b34c003".</p> <p>Tags: xml.attribute=true</p>

Table D.5: Identifiable

Class	Referrable (abstract)			
Package	M2::AUTOSARTemplates::GenericStructure::GeneralTemplateClasses::Identifiable			
Note	Instances of this class can be referred to by their identifier (while adhering to namespace borders).			
Base	ARObject			
Attribute	Datatype	Mul.	Kind	Note
shortName	Identifier	1	ref	This specifies an identifying shortName for the object. It needs to be unique within its context and is intended for humans but even more for technical reference. Tags: xml.enforceMinMultiplicity=true; xml.sequenceOffset=-100

Table D.6: Referrable

Class	Unit			
Package	M2::AUTOSARTemplates::SWComponentTemplate::Datatype::Units			
Note	This is a physical measurement unit. All units that might be defined should stem from SI units. In order to convert one unit into another factor and offset are defined. For the calculation from SI-unit to the defined unit the factor (factorSiToUnit) and the offset (offsetSiToUnit) are applied: $\text{unit} = \text{siUnit} * \text{factorSiToUnit} + \text{offsetSiToUnit}$ For the calculation from a unit to SI-unit the reciprocal of the factor (factorSiToUnit) and the negation of the offset (offsetSiToUnit) are applied: $\text{siUnit} = (\text{unit} - \text{offsetSiToUnit}) / \text{factorSiToUnit}$ Tags: atp.recommendedPackage=Units			
Base	ARElement , ARObject , CollectableElement , Identifiable , Multilanguage Referrable , PackageableElement , Referrable			
Attribute	Datatype	Mul.	Kind	Note
displayName	SingleLanguage UnitNames	0..1	aggr	This specifies how the unit shall be displayed in documents or in user interfaces of tools. The displayName corresponds to the Unit.Display in an ASAM MCD-2MC file. Tags: xml.sequenceOffset=20
factorSiToUnit	Float	0..1	attr	This is the factor for the conversion from and to siUnits. Tags: xml.sequenceOffset=30
offsetSiToUnit	Float	0..1	attr	This is the offset for the conversion from and to siUnits. Tags: xml.sequenceOffset=40

<i>Attribute</i>	<i>Datatype</i>	<i>Mul.</i>	<i>Kind</i>	<i>Note</i>
physicalDimension	PhysicalDimension	0..1	ref	This association represents the physical dimension to which the unit belongs to. Note that only values with units of the same physical dimensions might be converted. Tags: xml.sequenceOffset=50

Table D.7: Unit