

Document Title	Requirements on Diagnostic Log and Trace
Document Owner	AUTOSAR
Document Responsibility	AUTOSAR
Document Identification No	350
Document Classification	Auxiliary
Document Version	1.2.0
Document Status	Final
Part of Release	4.1
Revision	2

Document Change History			
Date	Version	Changed by	Change Description
31.10.2013	1.2.0	AUTOSAR Release Management	<ul style="list-style-type: none">• Renamed "RS_BSWAndRTEFeatures" into "RS_Features"• Editorial changes
10.02.2013	1.1.0	AUTOSAR Administration	<ul style="list-style-type: none">• TPS_STDT_0078 formatting• Traceability of BSWAndRTE_Features
30.11.2009	1.0.0	AUTOSAR Administration	Initial release

Disclaimer

This specification and the material contained in it, as released by AUTOSAR, is for the purpose of information only. AUTOSAR and the companies that have contributed to it shall not be liable for any use of the specification.

The material contained in this specification is protected by copyright and other types of Intellectual Property Rights. The commercial exploitation of the material contained in this specification requires a license to such Intellectual Property Rights.

This specification may be utilized or reproduced without any modification, in any form or by any means, for informational purposes only.

For any other purpose, no part of the specification may be utilized or reproduced, in any form or by any means, without permission in writing from the publisher.

The AUTOSAR specifications have been developed for automotive applications only. They have neither been developed, nor tested for non-automotive applications.

The word AUTOSAR and the AUTOSAR logo are registered trademarks.

Advice for users

AUTOSAR specifications may contain exemplary items (exemplary reference models, "use cases", and/or references to exemplary technical solutions, devices, processes or software).

Any such exemplary items are contained in the specifications for illustration purposes only, and they themselves are not part of the AUTOSAR Standard. Neither their presence in such specifications, nor any later documentation of AUTOSAR conformance of products actually implementing such exemplary items, imply that intellectual property rights covering such exemplary items are licensed under the same rules as applicable to the AUTOSAR Standard.

Table of Contents

1	Scope of Document	5
2	Conventions to be used	6
3	Acronyms and abbreviations	7
3.1	DLT term definition	7
3.2	DLT term definition	7
3.2.1	Log and trace message	7
3.2.2	User	7
3.2.3	Log	7
3.2.4	Trace	7
3.2.5	ECU ID	7
3.2.6	Session ID	7
3.2.7	Application ID	7
3.2.8	Context ID	7
3.2.9	Message ID	8
3.2.10	Log and trace level	8
3.2.11	Time	8
3.2.12	External client	8
4	Functional Overview	9
5	Requirements Specification	10
5.1	Functional Requirements	10
5.1.1	Configuration	10
5.1.2	Log and trace interfaces	10
5.1.2.1	Generic	10
5.1.2.2	Interface for SWCs	11
5.1.2.3	DET trace interface	12
5.1.2.4	DEM trace interface	12
5.1.2.5	RTE/VFB trace interface	13
5.1.3	Format of log and trace message	14
5.1.3.1	[SRS_DIt_00013] The transmitted data shall be packetized	14
5.1.3.2	[SRS_DIt_00014] The transport format shall be binary.	14
5.1.3.3	[SRS_DIt_00016] The format shall deal with Big and Little Endianess.	15
5.1.3.4	[SRS_DIt_00017] Each log and trace message shall contain a timestamp, which will be added to the message during reception of the message in the DLT module	15
5.1.3.5	[SRS_DIt_00018] A global message counter shall be implemented, to detect messages loss.	15
5.1.3.6	[SRS_DIt_00019] For each log message, a log level shall be provided.	16
5.1.3.7	[SRS_DIt_00020] The log and trace message shall contain a parameter, which represents the source of the log and trace message	16
5.1.3.8	[SRS_DIt_00021] There shall be a logical grouping for log messages by using different identifiers.	16
5.1.3.9	[SRS_DIt_00022] Each ECU shall have its unique ECU ID	16

5.1.3.10	[SRS_DIt_00023] The payload shall transport the parameters of a log and trace message.....	17
5.1.3.11	[SRS_DIt_00024] It shall be possible to transmit the parameters in a raw format.....	17
5.1.3.12	[SRS_DIt_00044] There shall be the possibility to transmit the parameters with additional information about themselves (self-description)..	17
5.1.3.13	[SRS_DIt_00025] It shall be possible to transmit ASCII text in log or trace messages.....	18
5.1.3.14	[SRS_DIt_00026] The data in non-verbose mode shall be described by an extra file	18
5.1.3.15	[SRS_DIt_00027] Each message shall have a unique identifier significant for identifying the source of the tracing.	18
5.1.4	Transport interfaces	18
5.1.4.1	Generic.....	18
5.1.4.2	Communication interface.....	20
5.1.4.3	DCM transport interface	21
5.1.5	Operational function.....	21
5.1.5.1	Initialization and shutdown	21
5.1.5.2	Normal operation.....	22
5.2	Non functional Requirements	23
5.2.1	[SRS_DIt_00041] DLT shall be a central software component in BSW for the log and trace functionality.....	23
5.2.2	[SRS_DIt_00042] The Log and trace SW component shall be part of the system during production phase.....	23
6	References	24

1 Scope of Document

This following specification defines the functional and non-functional requirements of the BSW module Diagnostic Log and Trace (DLT) for AUTOSAR Release 4.0.

This BSW component DLT is new to AUTOSAR since Release 4.0. The existing component DET provides only a minimal interface for Error Tracing and do not specify how trace data is stored.

The focus of this document is to specify the requirements for:

- The interface of DLT to other BSW modules
- The interface to RTE/VFB Tracing
- The interface to SWCs
- The transmission format of the log and trace messages
- The storage format of the log and trace messages
- The internal interface to the DLT communication module
- The configuration of DLT

The focus is NOT to specify:

- The transport layer of the communication over the DLT communication module

2 Conventions to be used

- The representation of requirements in AUTOSAR documents follows the table specified in [5].
- In requirements, the following specific semantics shall be used (based on the Internet Engineering Task Force IETF).

The key words "MUST", "MUST NOT", "REQUIRED", "SHALL", "SHALL NOT", "SHOULD", "SHOULD NOT", "RECOMMENDED", "MAY", and "OPTIONAL" in this document are to be interpreted as:

- **SHALL**: This word means that the definition is an absolute requirement of the specification.
- **SHALL NOT**: This phrase means that the definition is an absolute prohibition of the specification.
- **MUST**: This word means that the definition is an absolute requirement of the specification due to legal issues.
- **MUST NOT**: This phrase means that the definition is an absolute prohibition of the specification due to legal constraints.
- **SHOULD**: This word, or the adjective "RECOMMENDED", mean that there may exist valid reasons in particular circumstances to ignore a particular item, but the full implications must be understood and carefully weighed before choosing a different course.
- **SHOULD NOT**: This phrase, or the phrase "NOT RECOMMENDED" mean that there may exist valid reasons in particular circumstances when the particular behavior is acceptable or even useful, but the full implications should be understood and the case carefully weighed before implementing any behavior described with this label.
- **MAY**: This word, or the adjective „OPTIONAL“, means that an item is truly optional. One vendor may choose to include the item because a particular marketplace requires it or because the vendor feels that it enhances the product while another vendor may omit the same item. An implementation, which does not include a particular option, **MUST** be prepared to interoperate with another implementation, which does include the option, though perhaps with reduced functionality. In the same vein an implementation, which does include a particular option, **MUST** be prepared to interoperate with another implementation, which does not include the option (except, of course, for the feature the option provides.)

3 Acronyms and abbreviations

3.1 DLT term definition

DLT (**Diagnostic Log and Trace**) is a basic software module, which handles and stores log and trace messages produced by SWC itself or the interactions between SWC and RTE/VFB and by other Basic Software Modules. The log and trace messages are generated by calling APIs provided by the DLT module.

3.2 DLT term definition

This chapter describes the parameters and content of a log and trace message and additional terms.

3.2.1 Log and trace message

A log and trace message contains all data and options to specify a log and trace event in a software.

3.2.2 User

The user of DLT is the programmer of the software, which uses the DLT API to generate log and trace messages.

3.2.3 Log

The user generates log messages on demand. Each time the user wants to show some information about state changes or value changes, he adds an API call to DLT.

3.2.4 Trace

Trace messages can be generated by instrumentation of the code (e.g. VFB traces). The instrumented code calls the API of DLT.

3.2.5 ECU ID

ECU ID is the name of each ECU.

3.2.6 Session ID

Session ID is the identification number of a log or trace session. If a SWC is instantiated several times the log sessions get a new Session ID. A SWC can have several log or trace sessions. A BSW module uses the module-number as Session ID.

3.2.7 Application ID

Application ID is a short name of the SWC/BSW module. It identifies the SWC/BSW module in the log and trace message.

3.2.8 Context ID

Context ID is a user defined ID to group log and trace messages produced by a SWC/BSW module to distinguish functionality. Each Application ID can own several Context IDs. Context IDs are grouped by Application IDs. Context IDs shall be unique within an Application ID.

The identification of the source of a log and trace message is done with a pair of Application ID and Context ID.

3.2.9 Message ID

Message ID is the ID to characterize the information, which is transported by the message itself. A Message ID identifies a log or trace message uniquely. It can be used for identifying the source (in source code) of a message and it can be used for characterizing the payload of a message.

3.2.10 Log and trace level

A log level defines a classification for the severity grade of a log message.

The trace status provides information if a trace message should be send.

3.2.11 Time

Each log and trace message may contain a time attribute. The time attribute is a free defined time-value. It is the time since the start of the ECU.

3.2.12 External client

An external client is a tool, which can be run on a PC or another ECU, which is connected to DLT over DCM or over the DLT communication module.

4 Functional Overview

DLT provides a generic Logging and Tracing functionality for SWC's and the BSW modules RTE, DET and DEM. Main focuses of this document are to specify the container, how data is buffered locally and exported over a communication interface. The following figure shows, how DLT is integrated into the AUTOSAR architecture and how the main functionality of DLT shall be realized.

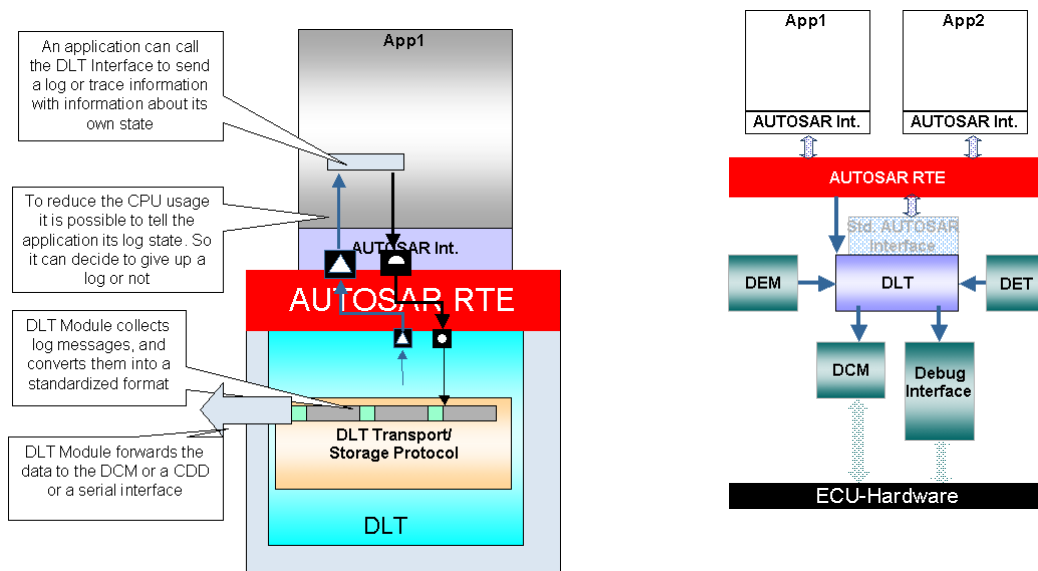

Figure 1: The position of DLT in the AUTOSAR layered architecture

DLT provides the following functionalities:

- Logging
 - Logging of errors, warnings and info messages from AUTOSAR SWC's, providing a standardized AUTOSAR interface
 - Gather all log and trace messages from all AUTOSAR SWC's in a centralized AUTOSAR service component (DLT) in BSW
 - Log messages from DET
 - Log messages from DEM
- Tracing
 - Trace RTE/VFB
- Control
 - Enable/disable individual log and trace messages
 - Control trace levels individually by back channel
- Generic
 - DLT available during debugging and production phase
 - Access over standard diagnosis or platform specific test interface
 - Security mechanisms to prevent misuse in production phase

5 Requirements Specification

5.1 Functional Requirements

5.1.1 Configuration

Configuration is specified in the individual chapters.

5.1.2 Log and trace interfaces

5.1.2.1 Generic

5.1.2.1.1 [SRS_Dlt_00001] The DLT shall transmit log and trace messages from several sources over a communication interface to a receiving external client.

Type:	Valid
Description:	The DLT module shall be a BSW module. It shall receive log and trace messages from several sources, like SWCs, some BSW modules and the RTE. These messages may be transmitted over a communication interface to an external client. Log and trace is a debugging mechanism needed by a lot of ECU's. A log and trace module shall provide a mechanism to gather log and trace messages from several sources. The log and trace module buffers the log and trace entries if necessary and shall have a connection to an external client.
Rationale:	Each Tier1 uses its own mechanisms to provide such a logging interface, using some internal or external debugging interfaces. The format of the logging content also differs from ECU to ECU. When testing several ECU's, many different tools and parsers are needed to get the right information out of the logs. A standard Diagnostic Logging Component with standardized logging content may help to reduce the testing efforts and enable new automated testing mechanisms. Also the number of tools could be reduced by a standard logging content and protocol.
Use Case:	<ul style="list-style-type: none"> • Development support • Functional Testing • Test Automation • Test against models • Driver intensive tests • Advanced Diagnostic Tracing, optional over telematic services
Dependencies:	--
Supporting Material:	--

|(RS_BRF_01440,RS_BRF_02240)

5.1.2.1.2 [SRS_Dlt_00002] All log and trace messages sent by an ECU shall have a standardized transmission format and a standardized storage format.

Type	Valid
Description:	A specified format shall be defined, which covers all requirements of log and trace. Some examples of the information stored in a log or trace message are the source, the context and the timestamp of the message to be able to

	filter the log and trace messages.
Rationale:	Since logging and tracing is an important mechanism for testability and proofing product quality, it is necessary to standardize the transmitted and stored data format. This is important for archiving, comparing and analyzing of log or trace messages. Also it may be possible to build common tools to interpret the incoming data.
Use Case:	<ul style="list-style-type: none"> • SWCs sends a log message • DLT sends the message over an interface to a data storing external client • The stored data of different ECU's are interpreted by the external client • Log and trace messages from different ECU's can be merged to understand relationship of behavior from distributed functionality
Dependencies:	--
Supporting Material:	see [1]

](RS_BRF_02240)

5.1.2.2 Interface for SWCs

5.1.2.2.1 [SRS_DIt_00003] SWCs shall have the possibility to send log or trace messages to the DLT module.

Type:	Valid
Description:	DLT shall offer a generic interface for SWCs independent from the type of log and trace message.
Rationale:	To reduce the amount of interfaces a generic and message independent interface may be implemented.
Use Case:	<ul style="list-style-type: none"> • Interfacing SWC with DLT module • Tracing or logging messages from SWCs
Dependencies:	--
Supporting Material:	see [1]

](RS_BRF_02144,RS_BRF_01440)

5.1.2.2.2 [SRS_DIt_00004] The DLT shall provide the actual set of log levels and the trace status to a SWC.

Type:	valid
Description:	SWC shall be aware of its log levels and trace status in order not to generate unnecessary log and trace messages. Log level and trace status should be checked by the SWCs before sending the messages.
Rationale:	The generation of unnecessary load on the communication interface and for the system has to be avoided. The DLT shall provide information about the actual configuration.
Use Case:	<ul style="list-style-type: none"> • Control of the log levels and of the trace status
Dependencies:	--
Supporting Material:	--

](RS_BRF_01440)

5.1.2.2.3 [SRS_DIt_00005] For each SWC the interface to DLT shall be configured.

Type:	valid
--------------	-------

Description:	The generation of the DLT interface of each SWC shall be enabled by the configuration.
Rationale:	Only the configured interfaces to the SWCs, which are using log and trace, shall be generated.
Use Case:	
Dependencies:	--
Supporting Material:	--

](RS_BRF_02200,RS_BRF_01440)

5.1.2.3 DET trace interface

5.1.2.3.1 [SRS_DIt_00006] Trace events from errors generated by BSW and SWCs shall be forwarded to the DLT module

Type	Valid
Description:	The DET receives trace events from errors generated by BSW and SWCs during debugging time. These events may be forwarded to the DLT module.
Rationale:	To have an overview of all log, trace and error messages and to set all of them in the correct context, it is important to have all these messages and events in one list. Also it is not practicable to use more than one mechanism to report errors, logs and traces to an external client. So all these sources may be forwarded to the DLT module.
Use Case:	<ul style="list-style-type: none"> In a debugging scenario, an SWC or BSW Module uses the DET interface to trace an error. This error is forwarded by the DET module to the DLT module. The DLT turns these events into a log message and sends it to the external client
Dependencies:	--
Supporting Material:	--

](RS_BRF_01440)

5.1.2.4 DEM trace interface

5.1.2.4.1 [SRS_DIt_00007] The DEM shall forward error events to the DLT module

Type	Valid
Description:	The DEM may forward error events to the DLT module.
Rationale:	It may be possible to get an overview of all error messages in an ECU. It may be possible to set them in the correct context with the error events reported by DEM. This makes an analysis of the reported errors more efficient and gives a correct picture of a failure situation.
Use Case:	<ul style="list-style-type: none"> A SWC or BSW module sets an DTC in the DEM. The DEM forwards this event to the DLT. The DLT turns these events in the DLT format and sends it over a communication interface to a DLT external client.
Dependencies:	--
Supporting Material:	--

](RS_BRF_01440)

5.1.2.5 RTE/VFB trace interface

5.1.2.5.1 [SRS_DIt_00008] RTE shall provide an interface for DLT to trace RTE/VFB calls.

Type	Valid
Description:	RTE shall provide the possibility to trace the VFB.
Rationale:	In the future more and more applications will be integrated in one ECU. As a consequence the communication between SWC is done locally and not over an external traceable bus like CAN or Flexray. It is important to trace the internal communication over RTE/VFB.
Use Case:	<ul style="list-style-type: none"> • Trace of VFB interface • Access to VFB for advanced diagnostic services, see RS_BRF_00224
Dependencies:	--
Supporting Material:	--

](RS_BRF_01440)

5.1.2.5.2 [SRS_DIt_00009] The DLT shall implement an interface to trace the RTE/VFB.

Type:	valid
Description:	VFB-Tracing shall be provided to the RTE generation system. The DLT module shall implement the handling of the RTE/VFB trace events.
Rationale:	To understand the communication between the SWCs it is important to trace all function calls to the SWCs except the RTE system function calls.
Use Case:	--
Dependencies:	--
Supporting Material:	--

](RS_BRF_01440)

5.1.2.5.3 [SRS_DIt_00010] A global switch shall be defined to switch on and off the RTE tracing.

Type:	valid
Description:	There shall be a global switch to turn on and off the RTE tracing of DLT at configuration time and at run time.
Rationale:	To have a high level activation for all RTE tracing messages a global switch is needed.
Use Case:	<ul style="list-style-type: none"> • Turning all tracing events for DLT off • Turning all tracing events for DLT on
Dependencies:	--
Supporting Material:	--

](RS_BRF_01440,RS_BRF_02160)

5.1.2.5.4 [SRS_DIt_00011] The DLT shall implement the handling of the RTE/VFB trace events

Type:	Valid
--------------	-------

Description:	The DLT may implement the handling of the RTE/VFB trace events. The groups may be configured at configuration time and the events may be assigned to one group. At run time the log level of each group can be set individually.
Rationale:	To understand the communication between the SWCs it is important to trace the function calls of a SWC.
Use Case:	--
Dependencies:	--
Supporting Material:	--

](RS_BRF_01440)

5.1.2.5.5 [SRS_Dlt_00012] DLT shall provide a solution to trace events linked to implicit communication mechanism

Type:	Valid
Description:	DLT may provide a solution to trace events linked to implicit communication mechanism. The implicit communication may be traced at runnable invocation and termination.
Rationale:	From the point of view of a SWC no extra routine for receiving or sending signals (Sender Receiver Communication) with implicit sending/receiving is called. The RTE manages the copying of the data before invocation and after exiting.
Use Case:	<ul style="list-style-type: none"> Tracing implicit communication of SWCs
Dependencies:	--
Supporting Material:	--

](RS_BRF_01440)

5.1.3 Format of log and trace message

5.1.3.1 [SRS_Dlt_00013] The transmitted data shall be packetized.

Type:	Valid
Description:	The log and trace messages shall be packet oriented. Each packet shall have one or several headers and a payload. The headers may be used for identifying, filtering and classifying the log and trace message. The payload shall contain the parameters given from the SWC or BSW.
Rationale:	DLT shall not care about the under laying transport protocol. DLT shall define the log or trace message format.
Use Case:	--
Dependencies:	--
Supporting Material:	--

](RS_BRF_02240,RS_BRF_01440,RS_BRF_01240)

5.1.3.2 [SRS_Dlt_00014] The transport format shall be binary.

Type:	Valid
Description:	The log and trace messages shall be in binary format. This is necessary for reducing the bandwidth and the CPU consumption.

Rationale:	Scope of the DLT component is to log and trace events without perturbing the ECU behavior. CPU consumption and bandwidth occupation may be reduced by using a binary format for the protocol.
Use Case:	--
Dependencies:	--
Conflicts	None
Supporting Material	--

|(RS_BRF_02240,RS_BRF_01440,RS_BRF_01240)

5.1.3.3 [SRS_Dlt_00016] The format shall deal with Big and Little Endianess.

Type:	Valid
Description:	The Endian format shall be considered in the message specification. The message shall signal which Endianess mode is actually used.
Rationale:	Big and Little Endianess of data representation has mixed occurrences in automotive ECUs. The message format shall be able to deal with both. To reduce CPU load it shall be possible to transport the data in the corresponding format of the ECU.
Use Case:	<ul style="list-style-type: none"> • Marker for format
Dependencies:	--
Supporting Material:	--

|(RS_BRF_02240,RS_BRF_01440,RS_BRF_01624)

5.1.3.4 [SRS_Dlt_00017] Each log and trace message shall contain a timestamp, which will be added to the message during reception of the message in the DLT module

Type:	Valid
Description:	Each log and trace message may contain a timestamp, which shall be added to the message during reception of the message in the DLT module.
Rationale:	For comparing and analyzing complex systems a timestamp is important. The time shall be in a defined granularity.
Use Case:	--
Dependencies:	--
Supporting Material:	--

|(RS_BRF_02240,RS_BRF_01440)

5.1.3.5 [SRS_Dlt_00018] A global message counter shall be implemented, to detect messages loss.

Type:	Valid
Description:	Every time a message from a SWC is received by the DLT module or other software module, it shall increment its global messages counter and set the counter in the message.
Rationale:	It is important to know if a message is lost. A receiving external client may then detect if messages are lost (e.g.because of a buffer overflow in DLT or network loss).
Use Case:	--
Dependencies:	--
Supporting Material:	--

|(RS_BRF_02240,RS_BRF_01440)

5.1.3.6 [SRS_Dlt_00019] For each log message, a log level shall be provided.

Type:	Valid
Description:	Log levels shall be for example error, fatal, debug, information or verbose.
Rationale:	Standard for logging tools
Use Case:	--
Dependencies:	--
Supporting Material:	--

|(RS_BRF_02240,RS_BRF_01440)

5.1.3.7 [SRS_Dlt_00020] The log and trace message shall contain a parameter, which represents the source of the log and trace message

Type:	Valid
Description:	The log and trace message may contain a parameter, which represents the source of the log and trace message.
Rationale:	The source can be identified by the Session ID of the port interface (port defined argument value) which was used to send the message from SWC to DLT.
Use Case:	--
Dependencies:	--
Supporting Material:	--

|(RS_BRF_02240,RS_BRF_01440)

5.1.3.8 [SRS_Dlt_00021] There shall be a logical grouping for log messages by using different identifiers.

Type:	Valid
Description:	There shall be additional parameters describing the group of the log and trace message.
Rationale:	Identifying some logically groups of log and trace to define some filtering action on the external client.
Use Case:	--
Dependencies:	--
Supporting Material:	--

|(RS_BRF_02240,RS_BRF_01440)

5.1.3.9 [SRS_Dlt_00022] Each ECU shall have its unique ECU ID

Type:	Valid
Description:	Each ECU may have its unique ECU ID, which may be a parameter of each log and trace message.
Rationale:	An external client receives tracing from different ECU's so it's important to know the source.
Use Case:	<ul style="list-style-type: none"> Distinguish tracing from different ECU's
Dependencies:	--

Supporting Material:	--
-----------------------------	----

](RS_BRF_01024)

5.1.3.10 [SRS_DIt_00023] The payload shall transport the parameters of a log and trace message.

Type:	valid
Description:	In the payload the parameters of each log and trace message from the SWC shall be transported. It may be possible to transport more than one parameter.
Rationale:	--
Use Case:	--
Dependencies:	--
Supporting Material:	--

](RS_BRF_02240,RS_BRF_01440)

5.1.3.11 [SRS_DIt_00024] It shall be possible to transmit the parameters in a raw format.

Type:	Valid
Description:	In most cases the parameter shall be transmitted in the raw format. This means that a separate file shall be provided containing the information about the transmitted parameters.
Rationale:	The non-verbose mode is for saving memory and bandwidth, because on the ECU only the ID's of the log and trace messages shall be stored.
Use Case:	<ul style="list-style-type: none"> Interpreting binary data
Dependencies:	--
Supporting Material:	--

](RS_BRF_02240)

5.1.3.12 [SRS_DIt_00044] There shall be the possibility to transmit the parameters with additional information about themselves (self-description).

Type:	valid
Description:	The log and trace messages shall contain a description of the parameters in verbose mode. No additional description file needs to be provided in this case.
Rationale:	In the verbose mode all parameters of the payload contain a self-description of their own type (e.g. integer/float, bit length) and some additional information (e.g. variable name, unit, etc).
Use Case:	<ul style="list-style-type: none"> Interpreting binary data
Dependencies:	--
Supporting Material:	--

](RS_BRF_02240)

5.1.3.13 [SRS_DIt_00025] It shall be possible to transmit ASCII text in log or trace messages.

Type:	Valid
Description:	Because log and trace messages often consists of texts, there shall be the possibility to transmit text strings. It may be possible to replace the given text by an ID which may be replaced by the text in the external client (Compare verbose – non-verbose mode).
Rationale:	In small ECU strings can not be stored because of their memory usage. For this reasons these strings may be replaced by a message ID.
Use Case:	--
Dependencies:	--
Supporting Material:	--

|(RS_BRF_02240,RS_BRF_01440)

5.1.3.14 [SRS_DIt_00026] The data in non-verbose mode shall be described by an extra file

Type:	valid
Description:	The data in non-verbose mode need to be described by an extra file. This file may be in a XML format.
Rationale:	In small ECUs memory is very limited, so temporarily buffered data shall be very small.
Use Case:	--
Dependencies:	--
Supporting Material:	--

|(RS_BRF_02240,RS_BRF_01440)

5.1.3.15 [SRS_DIt_00027] Each message shall have a unique identifier significant for identifying the source of the tracing.

Type:	Valid
Description:	Each message may have a unique identifier significant for identifying the source of the tracing. The ID of a specific message shall be permanent over the developing phase and shall be unique for a given ECU.
Rationale:	Easy identifying the right information in the log and trace message is very important. Unique message IDs helps doing this.
Use Case:	--
Dependencies:	--
Supporting Material:	--

|(RS_BRF_01024)

5.1.4 Transport interfaces

5.1.4.1 Generic

5.1.4.1.1 [SRS_DIt_00028] A control message shall be implemented to permit the external client to evaluate the round trip time.

Type:	valid
--------------	-------

Description:	A control message shall be implemented to permit the external client to evaluate the round trip time. The external client shall use this message to synchronize the individual log and trace messages from the different ECUs.
Rationale:	The log and trace time information may enable a user to understand what happens if there is a correlation among the recorded events. It is important to be able to refer all the events logged to an absolute time scale.
Use Case:	<ul style="list-style-type: none"> • An external client is able to synchronize packet reception from different sources • A round trip time calculation for each ECU is done • In each message the ECUs local time is transmitted • For every message from several ECUs a global time line can be calculated
Dependencies:	--
Supporting Material:	--

](RS_BRF_02160)

5.1.4.1.2 [SRS_DIt_00029] A protection against unauthorized access in production phase shall be provided.

Type:	valid
Description:	In production phase, the communication module (see SRS_DIt_00034) shall be disabled by default. In production phase DLT shall use the security mechanisms provided by DCM to handle the access to the log and trace messages. A mechanism shall be implemented to enable the communication module for testing phase permanently.
Rationale:	Only authorized accesses to DLT shall be allowed during production phase to avoid misuse.
Use Case:	<ul style="list-style-type: none"> • Avoid DLT misuse
Dependencies:	--
Supporting Material:	--

](RS_BRF_02008,RS_BRF_02208)

5.1.4.1.3 [SRS_DIt_00030] Monitoring and shaping of DLT log and trace event amount

Type:	Valid
Description:	DLT may shape the traffic bandwidth, depending on which transport interface is used (Debug or DCM) for communication. The traffic shaping shall be done at runtime.
Rationale:	Since DLT shall be used also in production phase, it is important that the traffic produced by the DLT component will not cause an overload of the network and the ECU resources.
Use Case:	<ul style="list-style-type: none"> • Bandwidth occupation has to be controlled • Bandwidth configuration has to be permitted
Dependencies:	--
Supporting Material:	--

](RS_BRF_02240,RS_BRF_01440)

5.1.4.1.4 [SRS_DIt_00031] The DLT shall be configurable at runtime.

Type:	Valid
Description:	DLT shall be configurable at runtime. DLT shall have for this propose

	runtime configurable variables which are initialized with the corresponding configuration parameters. It shall be possible to query the DLT runtime configuration. The configuration variables shall be writeable and readable over with some control mechanism triggered remotely.
Rationale:	To adapt DLT behavior to ECU and network resources it is important to have the capability of configuring it.
Use Case:	<ul style="list-style-type: none"> • Changing default levels with storing in NVRAM • Query DLT state
Dependencies:	--
Supporting Material:	--

](RS_BRF_02200)

5.1.4.1.5 [SRS_Dlt_00032] A protocol shall be implemented to be able to set and query the trace status and log levels of log and trace sources of each ECU.

Type:	valid
Description:	DLT shall support control messages to set the trace status and log level of each source of each ECU.
Rationale:	--
Use Case:	<ul style="list-style-type: none"> • Enabling/disabling trace and log messages at different levels. • Set the level of the log messages generated by different sources of each ECU.
Dependencies:	--
Supporting Material:	--

](RS_BRF_02240,RS_BRF_01440)

5.1.4.1.6 [SRS_Dlt_00033] A list of all log and trace sources of an ECU shall be accessible from the external client.

Type:	Valid
Description:	It shall be possible to get a list of all application IDs and context IDs with corresponding trace status and log levels which are registered to the DLT module.Each SWC or BSW module which wants to produce trace or log messages shall register to the DLT module.
Rationale:	Users need to know what information can be traced or logged in order to monitor ECU activity.
Use Case:	<ul style="list-style-type: none"> • Log messages from different ECU's can be merged to understand relationship of behavior from distributed applications. • Set the level of the tracing generated by different sources of each ECU.
Dependencies:	--
Supporting Material:	--

](RS_BRF_02240,RS_BRF_02168)

5.1.4.2 Communication interface

5.1.4.2.1 [SRS_Dlt_00034] DLT shall support a generic API for communicating over a DLT communication module.

Type:	valid
--------------	-------

Description:	At debugging phase a communication interface with a high bandwidth is needed. This communication interface is out of scope of the AUTOSAR specification. To use this communication interface with DLT a generic API shall be defined. The user shall be able to implement a board specific communication module to communicate over a board specific communication interface.
Rationale:	--
Use Case:	--
Dependencies:	--
Supporting Material:	--

](RS_BRF_01440,RS_BRF_01056)

5.1.4.3 DCM transport interface

5.1.4.3.1 [SRS_Dlt_00035] The DCM shall provide an interface for DLT to transport log and trace messages over a diagnostic session.

Type:	Valid
Description:	DCM shall provide an interface for DLT to send and receive data over the diagnostic service. Log and trace messages are sent over this service and control messages for DLT are received. Because log and trace messages are event triggered and the storage on the ECU is limited, these messages shall be sent when they occur. As diagnostic services can only send a small amount of data, the amount of data shall be limited, see SRS_Dlt_00030.
Rationale:	DLT needs an interface to send log and trace message out of the ECU. DCM provides a bus independent access to the ECU over standardized diagnostics. This is available during production phase and provides a secured session control. As diagnostic services can only send a small amount of data, the amount of data shall be limited, see SRS_Dlt_00030. For higher bandwidth the communication module shall be used, see SRS_Dlt_00034.
Use Case:	<ul style="list-style-type: none"> • Transmitting log and trace message during a diagnostic session • Advanced Diagnostic Tracing, optional over telematic services
Dependencies:	SRS_Dlt_00030, SRS_Dlt_00034
Supporting Material:	--

](RS_BRF_02144,RS_BRF_01440,RS_BRF_01056)

5.1.5 Operational function

5.1.5.1 Initialization and shutdown

5.1.5.1.1 [SRS_Dlt_00036] The DLT shall provide a buffer for storing log and trace messages before initialization

Type:	Valid
Description:	The DLT may provide a buffer for storing log and trace messages. This may be a standard C-initialized buffer which shall be read out after init of DLT.
Rationale:	This requirement shall guarantee that the DLT module can provide its services to other BSW modules also before the complete initialization of all BSW modules.
Use Case:	<ul style="list-style-type: none"> • Logging is available at startup phase

	<ul style="list-style-type: none"> Logging is available during shutdown process
Dependencies:	--
Supporting Material:	--

](RS_BRF_01440)

5.1.5.2 Normal operation

5.1.5.2.1 [SRS_DIt_00037] There shall be a buffer to store log and trace message locally.

Type:	Valid
Description:	If the communication module is not enabled or no external client for dumping log and trace message is connected, log and trace messages shall be stored locally in a memory buffer. The size of the buffer shall be set at configuration time.
Rationale:	To prevent a lack of communication e.g. at startup or if no external client is connected, the DLT shall store some messages to be dumped as soon as communication channel is available.
Use Case:	<ul style="list-style-type: none"> ECU startup No communication available
Dependencies:	--
Supporting Material:	--

](RS_BRF_02184)

5.1.5.2.2 [SRS_DIt_00038] A mechanism shall be implemented to be able to set the trace status and log levels of registered application IDs and context IDs of each SWC.

Type:	valid
Description:	DLT shall permit to turn off or on traces or to set log levels for registered application IDs and context IDs at runtime.
Rationale:	To gain efficiency in bandwidth and ECU resource usage a mechanism shall be provided to tune the transmission from SWCs to DLT. The DLT module shall provide some control variables which represent the actual log levels and trace status of the applications and contexts.
Use Case:	<ul style="list-style-type: none"> Enabling/disabling trace status and log levels.
Dependencies:	--
Supporting Material:	--

](RS_BRF_02184,RS_BRF_01440)

5.1.5.2.3 [SRS_DIt_00039] The DLT shall provide the possibility to store configuration data in a persistent way.

Type:	Valid
Description:	Some of the log and trace configurations like specific log levels shall be stored persistent.
Rationale:	The DLT can be configured at runtime. Some of this configuration data has to be stored to guarantee that at every startup the configuration would be the same.
Use Case:	---

Dependencies:	--
Supporting Material:	--

](RS_BRF_01440,RS_BRF_01824)

5.1.5.2.4 [SRS_DIt_00040] the DLT component shall be able to filter log and trace messages

Type:	valid
Description:	In order to adapt network traffic to bandwidth availability, the DLT component may be able to filter log and trace messages. A policy shall be defined to distinguish messages by different log and trace levels. The configuration of the filter level may be different for storing log and trace messages temporarily and communication over DCM or the DLT communication module.
Rationale:	--
Use Case:	--
Dependencies:	--
Supporting Material:	--

](RS_BRF_01440)

5.2 Non functional Requirements

5.2.1 [SRS_DIt_00041] DLT shall be a central software component in BSW for the log and trace functionality.

Type:	valid
Description:	Only one SW module per ECU shall gather the log and trace messages centrally.
Rationale:	None
Use Case:	None
Dependencies:	--
Supporting Material:	--

](RS_BRF_01440)

5.2.2 [SRS_DIt_00042] The Log and trace SW component shall be part of the system during production phase

Type:	valid
Description:	The Log and trace SW component may be also part of the system during production phase. It is needed for use cases like test drives and remote diagnosis.
Rationale:	None
Use Case:	<ul style="list-style-type: none"> • Test drives • Advanced remote diagnosis
Dependencies:	--
Supporting Material:	--

](RS_BRF_01016)

6 References

- [1] Requirements on AUTOSAR Features
AUTOSAR_RS_Features.pdf
- [2] Specification of RTE,
AUTOSAR_SWS_RTE.pdf
- [3] Layered Software Architecture,
AUTOSAR_EXP_LayeredSoftwareArchitecture.pdf.pdf
- [4] Specification of Development Error Trace,
AUTOSAR_SWS_DevelopmentErrorTracer.pdf
- [5] Software Standardization Template
AUTOSAR_TPS_StandardizationTemplate.pdf