

Document Title	Description of the AUTOSAR standard errors
Document Owner	AUTOSAR
Document Responsibility	AUTOSAR
Document Identification No	377
Document Classification	Auxiliary

Document Version	1.2.0
Document Status	Final
Part of Release	4.1
Revision	2

Document Change History			
Date	Version	Changed by	Change Description
31.10.2013	1.2.0	AUTOSAR Release Management	Removal of reference to obsolete communication stack types
28.01.2013	1.1.0	AUTOSAR Administration	Adaptation according to AUTOSAR Glossary changes
30.11.2009	1.0.0	AUTOSAR Administration	Initial Release

Disclaimer

This specification and the material contained in it, as released by AUTOSAR, is for the purpose of information only. AUTOSAR and the companies that have contributed to it shall not be liable for any use of the specification.

The material contained in this specification is protected by copyright and other types of Intellectual Property Rights. The commercial exploitation of the material contained in this specification requires a license to such Intellectual Property Rights.

This specification may be utilized or reproduced without any modification, in any form or by any means, for informational purposes only.

For any other purpose, no part of the specification may be utilized or reproduced, in any form or by any means, without permission in writing from the publisher.

The AUTOSAR specifications have been developed for automotive applications only. They have neither been developed, nor tested for non-automotive applications.

The word AUTOSAR and the AUTOSAR logo are registered trademarks.

Advice for users

AUTOSAR specifications may contain exemplary items (exemplary reference models, "use cases", and/or references to exemplary technical solutions, devices, processes or software).

Any such exemplary items are contained in the specifications for illustration purposes only, and they themselves are not part of the AUTOSAR Standard. Neither their presence in such specifications, nor any later documentation of AUTOSAR conformance of products actually implementing such exemplary items, imply that intellectual property rights covering such exemplary items are licensed under the same rules as applicable to the AUTOSAR Standard.

Table of Contents

1	Purpose.....	6
2	Relation to other documents.....	7
3	Guide to the document	8
4	Generic Mechanisms.....	9
4.1	Report to the Diagnostic Event Manager (DEM)	9
4.1.1	Summary.....	9
4.1.2	Roles of the modules	9
4.1.2.1	Module reporting the error (other BSW or SWC).....	9
4.1.2.2	Diagnostic Event Manager	9
4.1.2.3	Function Inhibition Manager	10
4.1.2.4	RTE.....	11
4.1.2.5	Notification to SWCs	11
5	Communication related errors	12
5.1	Overview	12
5.1.1	Error handling mechanisms.....	12
5.1.2	Error list for CAN stack.....	12
5.1.3	Mappings of EH mechanisms to hardware failure modes	14
5.2	Loss of communication channel	16
5.2.1	CAN Bus Off.....	16
5.2.1.1	Summary.....	16
5.2.1.2	Roles of the modules.....	16
5.2.2	CAN Controller Hardware Timeout.....	19
5.2.2.1	Summary.....	19
5.2.2.2	Roles of the modules.....	19
5.3	Signal error.....	22
5.3.1	CAN Transmission buffer full.....	22
5.3.1.1	Summary.....	22
5.3.1.2	Roles of the modules.....	22
5.3.2	CAN Reception DLC error.....	24
5.3.2.1	Summary.....	24
5.3.2.2	Roles of the modules.....	24
5.3.3	COM RX Deadline Monitoring	26
5.3.3.1	Summary.....	26
5.3.3.2	Roles of the modules.....	26
5.3.4	COM TX Deadline Monitoring	27
5.3.4.1	Summary.....	27
5.3.4.2	Roles of the modules.....	28
5.3.5	CAN Transport Protocol error during transmission.....	28
5.3.5.1	Summary.....	29
5.3.5.2	Roles of the modules.....	29
5.3.6	CAN Transport Protocol error during reception	31
5.3.6.1	Summary.....	31
5.3.6.2	Roles of the modules.....	31
5.3.7	CANNM TX Deadline Monitoring.....	32
5.3.8	PDU replication error.....	33
5.3.8.1	Summary.....	33
5.3.8.2	Roles of the modules.....	33
5.3.9	PDU counter error	34

5.3.9.1	Summary.....	34
5.3.9.2	Roles of the modules.....	34
5.3.10	Client / Server timeout.....	35
5.3.10.1	Summary.....	35
5.3.10.2	Roles of the modules.....	35
6	NVRAM related errors	37
6.1	Overview	37
6.1.1	Error handling mechanisms.....	37
6.1.2	Error list for NVRAM stack	38
6.1.3	Mappings of EH mechanisms to NVRAM hardware failure modes	39
6.2	Driver level errors.....	42
6.2.1	Flash write job error	42
6.2.1.1	Summary.....	42
6.2.1.2	Roles of the modules.....	43
6.2.2	Flash erase job error	45
6.2.2.1	Summary.....	45
6.2.2.2	Roles of the modules.....	45
6.2.3	Flash read job error.....	48
6.2.3.1	Summary.....	48
6.2.3.2	Roles of the modules.....	49
6.2.4	Flash compare job error	51
6.2.4.1	Summary.....	51
6.2.4.2	Roles of the modules.....	52
6.2.5	External Flash Hardware ID Mismatch.....	53
6.2.5.1	Summary.....	53
6.2.5.2	Roles of the modules.....	53
6.2.6	EEPROM write job error.....	55
6.2.6.1	Summary.....	55
6.2.6.2	Roles of the modules.....	55
6.2.7	EEPROM erase job error	58
6.2.7.1	Summary.....	58
6.2.7.2	Roles of the modules.....	58
6.2.8	EEPROM read job error	61
6.2.8.1	Summary.....	61
6.2.8.2	Roles of the modules.....	62
6.2.9	EEPROM compare job error	64
6.2.9.1	Summary.....	64
6.2.9.2	Roles of the modules.....	64
6.3	EEPROM Abstraction / Flash Emulation level errors.....	66
6.3.1	FEE consistency check error.....	66
6.3.1.1	Summary.....	66
6.3.1.2	Roles of the modules.....	67
6.3.2	EA consistency check error.....	69
6.3.2.1	Summary.....	69
6.3.2.2	Roles of the modules.....	69
6.4	NVRAM manager level errors	72
6.4.1	NVM CRC check	72
6.4.1.1	Summary.....	72
6.4.1.2	Roles of the modules.....	73
6.4.2	NVM write verification error	74

6.4.2.1	Summary.....	74
6.4.2.2	Roles of the modules.....	74
6.4.3	Static block check error.....	75
6.4.3.1	Summary.....	75
6.4.3.2	Roles of the modules.....	76
6.4.4	Loss of redundancy.....	77
6.4.4.1	Summary.....	77
6.4.4.2	Roles of the modules.....	77
6.4.5	NVM API request failure.....	79
6.4.5.1	Summary.....	79
6.4.5.2	Roles of the modules.....	79

1 Purpose

The purpose of the document is to:

- Give an overview of the dysfunctional behavior of the BSW not limited to one specific module ;
- Clarify error handling mechanisms to guarantee the same behavior for any BSW implementation and permit a safer exchange of module ;
- List the BSW mechanisms provided for application software and possibly point out the lacks to be fulfilled ;
- Give the failure modes coverage of the different mechanisms in terms of detection and recovery for a safety analysis point of view.

This document is aimed at developers of BSW-modules and application/SW-C developers.

The document describes all the existing errors handled by the AUTOSAR Basic Software and the way the architecture reacts to these errors according to the FDIR process (Fault, Detection, Isolation and Recovery).

The document describes also the coverage of the identified failure modes for each existing error handling mechanism. The failure modes are assumed to be random failures related to the hardware. The incorporated SW mechanisms to detect these HW failures may however also detect SW (design) faults. The mechanisms are mapped to the list of failure modes and the effect of the mechanisms in terms of degree of detection and recovery are evaluated.

Limitations

For the time being, the scope of the document is limited to the CAN communication stack and to the memory stack.

This document is only descriptive and does not contain requirements. Functionalities and requirements of the Basic Software modules are specified in the specification documents.

The document describes only the standard errors included in an AUTOSAR architecture. Specific errors can be added because of specific implementation and/or specific hardware properties.

2 Relation to other documents

This document is related to many other documents published within AUTOSAR. The purpose of this document is not to replace any of these other documents, but to give a complete view of the error handling in the BSW. Consequently there is a significant amount of overlap between this document and other documents. Note that this document is only descriptive and does not contain requirements.

3 Guide to the document

Here is a summary of the content of the following chapters.

- [Chapter 4: Generic mechanisms](#)
This chapter describes generic error handling mechanisms.
- [Chapter 5: Communication related errors](#)
 - [Chapter 5.1: Overview](#)
This chapter gives an overview of the existing error handling mechanisms in the communication stack. It describes also the mappings of each mechanism to the identified failure modes.
 - [Chapter 5.X](#)
These chapters describe precisely the AUTOSAR architecture behavior for each error of the communication stack.
- [Chapter 6: Memory related errors](#)
 - [Chapter 6.1: Overview](#)
This chapter gives an overview of the existing error handling mechanisms in the memory stack. It describes also the mappings of each mechanism to the identified failure modes.
 - [Chapter 6.X](#)
These chapters describe precisely the AUTOSAR architecture behavior for each error of the memory stack.

For each error, a figure presents an information-flow summary for that error, and indicates where the error is detected, mitigated or recovered. Also for each module, a table details the specific items regarding error handling:

Detection	This describes how the module detects or is notified of this error case.
Reaction	This indicates the internal reaction of the module (e.g. internal state changes).
Report	This indicates how the error is notified to other modules in the stack or to the AUTOSAR infrastructure.
Recovery	This indicates how / if the error is recovered or mitigated by the module.

4 Generic Mechanisms

This section describes generic mechanisms which are involved in the error handling strategies for different errors mentioned in this document. These mechanisms will not be described again in the description of the errors in chapters 5 and 6.

4.1 Report to the Diagnostic Event Manager (DEM)

4.1.1 Summary

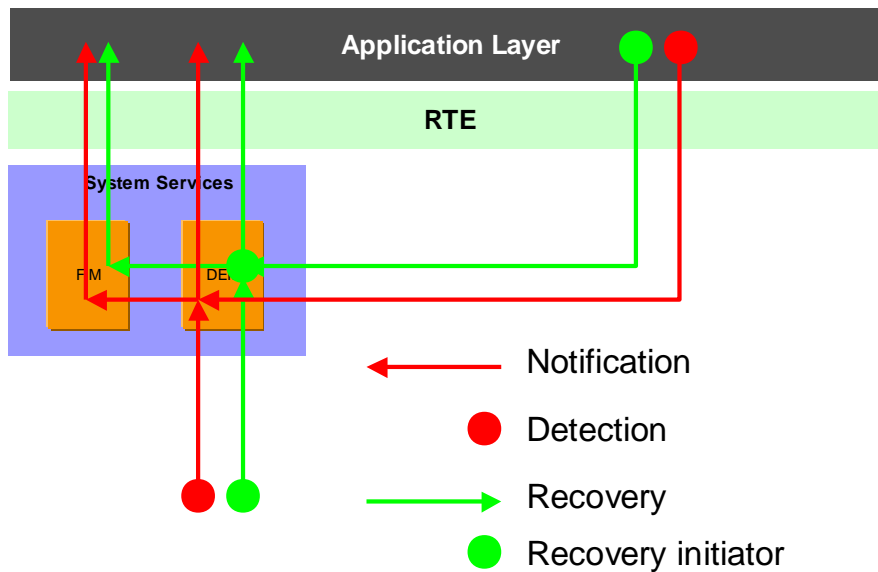

Figure 1: Information path for errors reported to the DEM

4.1.2 Roles of the modules

4.1.2.1 Module reporting the error (other BSW or SWC)

Detection	depend on the SWC or BSW Module
Reaction	depend on the SWC or BSW Module
Report	<ul style="list-style-type: none"> BSWs report the new status of the event with the <code>Dem_ReportErrorStatus</code> API. SWCs report the new status of the event with the <code>Dem_SetEventStatus</code> API (through the RTE)
Recovery	Implementation specific

4.1.2.2 Diagnostic Event Manager

Detection	
------------------	--

	<ul style="list-style-type: none"> The DEM is notified by BSWs with the <code>Dem_ReportErrorStatus</code> API when an error occurs (<code>DEM_EVENT_STATUS_FAILED</code> or <code>DEM_EVENT_STATUS_PREFAILED</code>) or is recovered (<code>DEM_EVENT_STATUS_PASSED</code> or <code>DEM_EVENT_STATUS_PREPASSED</code>). The DEM is notified by SWCs with the <code>Dem_SetEventStatus</code> API when an error occurs (<code>DEM_EVENT_STATUS_FAILED</code> or <code>DEM_EVENT_STATUS_PREFAILED</code>) or is recovered (<code>DEM_EVENT_STATUS_PASSED</code> or <code>DEM_EVENT_STATUS_PREPASSED</code>).
Reaction	[SWS_Dem_00184] Storage of the event status [SWS_Dem_00190] Handling of a FreezeFrame
Report	<ul style="list-style-type: none"> [SWS_Dem_00016] Depending on the DEM configuration, it can inform the FIM [SWS_Dem_00029] and/or a SWC with the <code>EventStatusChanged</code> operation of the <code>CallbackEventStatusChange</code> DEM client server interface (connected to the configurable interfaces <code>EventStatusChanged</code> [DEM285] or <code>DTCStatusChanged</code> [SWS_Dem_00284] function). A SWC can poll the DEM to get the status of an Event (operation <code>GetEventStatus</code> of the <code>DiagnosticMonitor</code> client server interface, connected to the <code>Dem_GetEventStatus</code> function [SWS_Dem_00195])
Recovery	The DEM has some <ul style="list-style-type: none"> [DEM127] healing capabilities (by a defined healing cycle for BSWs or monitor function for SWC). [DEM004] debouncing capabilities

4.1.2.3 Function Inhibition Manager

Detection	Different detection mechanisms exist: <ul style="list-style-type: none"> access to the DEM information (polling for the Event attached to the requested FID with <code>Dem_GetEventStatus</code> [SWS_Fim_00072], or dump of the event status on startup [SWS_Fim_00018]) [SWS_Fim_00021] notification by the DEM by the <code>Fim_DemTriggerOnEventStatus</code> callout
Reaction	Depending on the implementation, storage of the Event status when a change is reported by the DEM.
Report	The FIM can be polled by the SWCs with <code>Fim_GetFunctionPermission</code> [SWS_Fim_00011]. It does not notify the SWCs.
Recovery	

4.1.2.4 RTE

The RTE provides access to the DEM and FIM operations for the SWCs. It executes the runnables associated to the DEM monitors (DEM callbacks) when information is required from a SWC or when a SWC must be notified.

No specific functionalities are provided for the DEM by the RTE.

4.1.2.5 Notification to SWCs

Detection	Notification by the FIM or DEM (through the RTE)
Reaction	N/A
Report	N/A
Recovery	N/A

5 Communication related errors

5.1 Overview

5.1.1 Error handling mechanisms

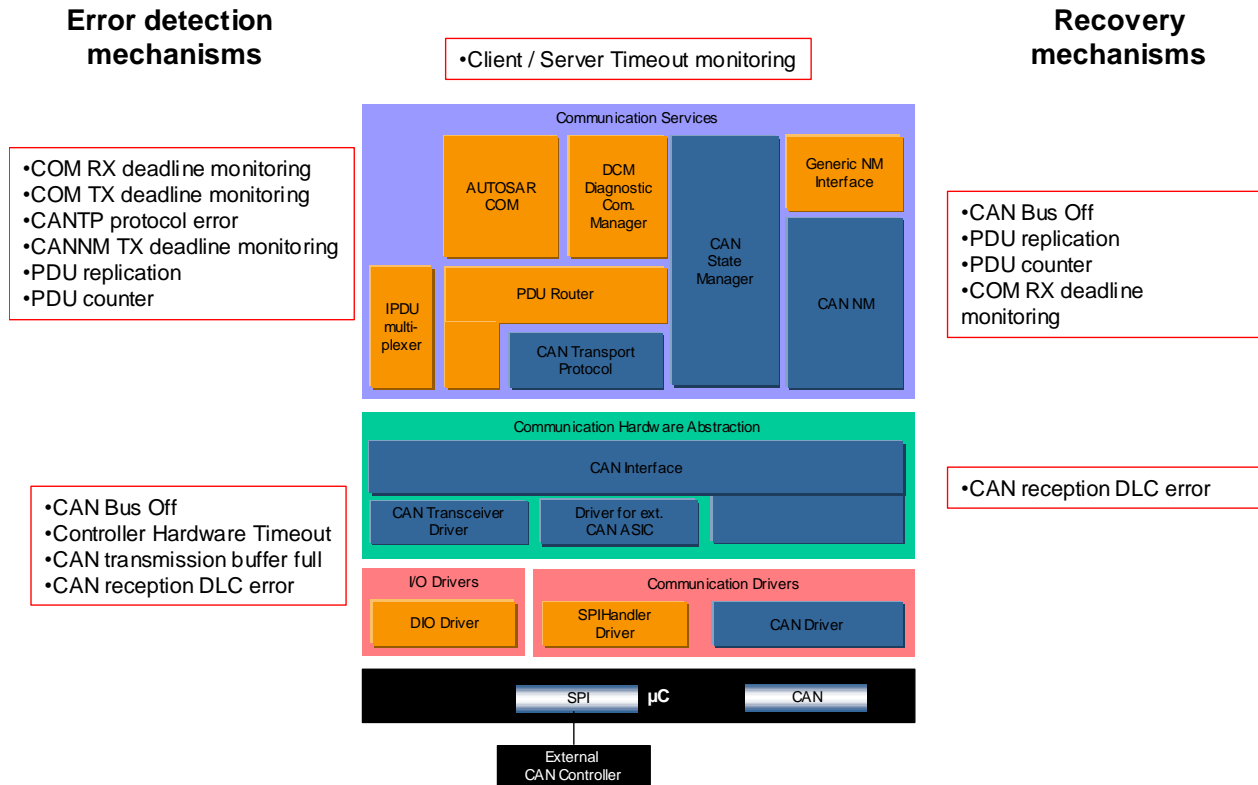

Figure 2: CAN Error Handling Mechanisms Overview

5.1.2 Error list for CAN stack

Error	Description	Detection module	DEM error (reporter in bold)	Mitigator with BSW recovery actions
Driver level errors				
CAN Bus Off	Bus Off error on a CAN network	CAN	CANSM_E_BUS_OFF¹	CANSM: → Bus Off Recovery state machine

¹ CANSM_E_BUS_OFF is not the name of a DEM event (generated by the DEM configuration). It is a CANSM configuration element, which permits to define different DEM events per CAN network.

Error	Description	Detection module	DEM error (reporter in bold)	Mitigator with BSW recovery actions
CAN Controller Hardware Timeout	Communication with the CAN controller timed out	CAN	CANSM_E_CONTROLLER_TIMEOUT²	CANSM: → Timeout Recovery state machine
Signal errors				
CAN Transmission buffer full	Cannot transmit a new message because the transmission queue is full	CANIF	not reported to the DEM reported to the CANIF reported to the SW-Cs	NONE indirectly, TX deadline monitoring
CAN Reception DLC error	CAN frame received with an unexpected Data Length Counter, and DLC check enabled	CANIF	CANIF_E_PARAM_DLC	NONE indirectly, RX deadline monitoring
COM RX Deadline Monitoring	An expected message was not received in time by COM.	AUTOSAR COM	not reported to the DEM reported to the SW-Cs ³	AUTOSAR COM/SW-C
COM TX Deadline Monitoring	Timeout while waiting for the confirmation of a transmission.	AUTOSAR COM	not reported to the DEM reported to the SW-Cs	SW-C
CAN Transport Protocol error during reception CAN Transport Protocol error during transmission	Timeout during the reception or transmission) of a CAN TP message. (or other protocol error)	CANTP	CANTP_E_COM	Users, DCM
CANNM TX Deadline Monitoring	Error in the transmission of an NM message	CANNM	not reported to the DEM	CANNM/SW-C
PDU Replication error	A replicated PDU is not identical in all copies.	AUTOSAR COM	not reported to the DEM	AUTOSAR COM
PDU counter error	The PDU counter differs from the expected counter.	AUTOSAR COM	not reported to the DEM	AUTOSAR COM
Client/Server timeout	Timeout in a client/server operation.	AUTOSAR COM/RTE	not reported to the DEM	SW-C

Table 1: CAN stack error list

² As for CANSM_E_BUS_OFF, CANSM_E_CONTROLLER_TIMEOUT is not the name of a DEM event (generated by the DEM configuration). It is a CANSM configuration element, which permit to define different DEM events per CAN network.

³ It could have too much impact to raise a DEM event for each missed deadline, and the event would not permit to identify the failing part. See 5.3.3 COM RX Deadline Monitoring and 5.3.4 COM TX Deadline Monitoring for details of the COM timeout handling in AUTOSAR.

5.1.3 Mappings of EH mechanisms to hardware failure modes

The following communication hardware failure modes have been considered:

ID	Short name	Description
CH01	Permanent loss of one CAN frame ID type	All CAN frames with a specific ID are lost during reception or transmission.
CH02	Temporary loss of one CAN frame	One CAN frame is temporarily lost during reception or transmission.
CH03	One repeated CAN frame	One CAN frame (with identical ID and content) is unintentionally repeated one or more times on the CAN bus. Not flooded bus.
CH04	One spurious CAN frame	One CAN frame with credible content is spuriously transmitted (and hence received).
CH05	CAN frames out of sequence	The order in which CAN frames have been sent is not the order in which they are received.
CH06	One corrupt CAN frame	The content of one CAN frame is corrupted
CH07	One delayed CAN frame	One expected CAN frame transfer is delayed compared to expected transfer.
CH08	CAN bus blocked	CAN communication is lost for all users
CH09	CAN bus flooded	CAN frames are continuously transmitted on the CAN bus.
CH10	Wrong routing	CAN frame is received by an incorrect destination or received from wrong source.
CH11	Permanent loss of one CAN user (ECU)	One CAN user cannot transmit nor receive

Table 2: Communication hardware failures modes

The tables below show error handling mechanisms relevant for each failure mode (hereafter abbreviated as FM) and a qualitative estimation of the efficiency of the mechanisms. The qualitative measure is defined by:

- A_D – Full coverage for the detection of the considered FM
- A_R – Full coverage for the recovery of the considered FM
- P_D – Partial coverage for the detection of the considered FM
- P_R – Partial coverage for the recovery of the considered FM

ID	Short Description	Bus Off	controller hardware timeout	Transmission buffer full	Reception DLC error	Reception deadline monitoring	Transmission deadline monitoring	PDU Replication	PDU Counter
CH01	Permanent loss of one CAN frame ID type		P_D			A_D P_R		A_D P_R	
CH02	Temporary loss of one CAN frame					A_D P_R		A_D P_R	A_D
CH03	One repeated CAN frame							A_D A_R	A_D A_R
CH04	One spurious				P_D			A_D	P_D

ID	Short Description	Bus Off	controller hardware timeout	Transmission buffer full	Reception DLC error	Reception deadline monitoring	Transmission deadline monitoring	PDU Replication	PDU Counter
	CAN frame				A_R			A_R	A_R
CH05	CAN frames out of sequence							A_D P_R	A_D P_R
CH06	One corrupt CAN frame				P_D			A_D A_R	P_D
CH07	One delayed CAN frame					A_D P_R			
CH08	CAN bus blocked	A_D P_R		A_D		A_D P_R	A_D		
CH09	CAN bus flooded					A_D P_R	A_D	P_D P_R	P_D
CH10	Wrong routing				P_D P_R	P_D P_R		A_D P_R	P_D P_R
CH11	Permanent loss of one CAN user (ECU)					A_D P_R			

Table 3: Mappings of detection and recovery mechanisms to the CAN failure modes

5.2 Loss of communication channel

5.2.1 CAN Bus Off

5.2.1.1 Summary

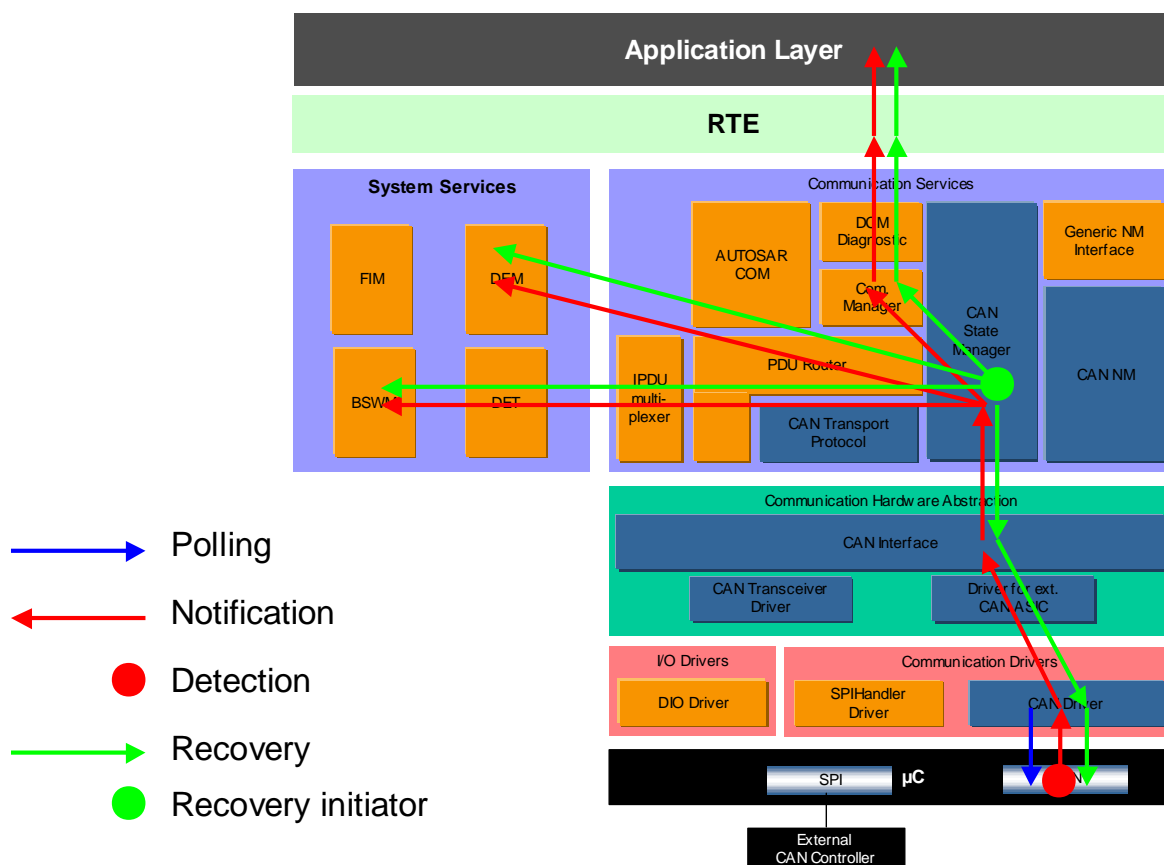

Figure 3: Information path for the CAN bus off error

Note: The AUTOSAR COM module (or other modules like CANNM or CANTP) will react on a BusOff indirectly because of the loss of the communication channel, but it is not aware of the specific kind of error. For this reason, these modules are not considered in this section.

5.2.1.2 Roles of the modules

5.2.1.2.1 CAN controller (peripheral)

Detection	HW dependant.
------------------	---------------

Reaction	[SWS_Can_00274] Any bus-off recovery from the CAN controller shall be disabled.
Report	Depending on the CAN Driver configuration: <ul style="list-style-type: none"> • Log the error in a register • Report the error to the CAN Driver if interrupt configured
Recovery	See CAN State Manager . [SWS_Can_00274] Any bus-off recovery from the CAN controller shall be disabled.

5.2.1.2.2 CAN Driver

Detection	[SWS_Can_00020] [CAN019] [SWS_Can_00099] Depending on the CAN Driver configuration: <ul style="list-style-type: none"> • [SWS_Can_00109] Polling of the CAN controller register • Activation by an interrupt
Reaction	[SWS_Can_00272] The driver transitions to <code>CANIF_CS_STOPPED</code> [SWS_Can_00273] Try to cancel pending messages
Report	[SWS_Can_00020] The error is reported to the CAN Interface by the <code>CanIf_ControllerBusOff(controller)</code> API.
Recovery	See CAN State Manager .

5.2.1.2.3 CAN Interface

Detection	Notified by <code>CanIf_ControllerBusOff(controller)</code> (see CAN Driver above)
Reaction	[SWS_CanIf_00298] The controller operation mode is set to <code>CANIF_CS_STOPPED</code>
Report	The error is reported to the CAN State Manager by the <code>CanSm_ControllerBusOff(controller)</code>
Recovery	The recovery is triggered by the CAN State Manager: <ul style="list-style-type: none"> • <code>CanIf_SetControllerMode(Controller, CANIF_CS_STARTED)</code>. • <code>Can_InitController(Controller, *Config)</code>. • <code>Can_SetControllerMode(Controller, CAN_T_STARTED)</code>.

5.2.1.2.4 CAN State Manager

Detection	Notified by <code>CanSm_ControllerBusOff(controller)</code> (see CAN Interface above)
Reaction	<ul style="list-style-type: none"> • Count the bus-off events • Start the error recovery mechanism
Report	<ul style="list-style-type: none"> • [CANSM292, CANSM295, CANSM299, and CANSM301] If the error is confirmed, it is reported to the DEM. If the recovery succeeds, the event is cleared from the DEM.

	<p>[CANSM070] The DEM event for this error is configured per CAN network in the CANSM_E_BUS_OFF configuration</p> <ul style="list-style-type: none"> • [CANSM338, CANSM341] CANSM informs the Communication Manager about the communication status (COMM_SILENT_COMMUNICATION, COMM_FULL_COMMUNICATION, notified with ComM_BusSM_ModeIndication) • [CANSM354] CANSM informs the BSW State Manager of the BusOff event. • [CANSM355, CANSM356] CANSM informs the BSW State Manager about the request to change the Communication mode (with BswM_CanSM_RequestMode)
Recovery	<p>[CANSM286] The CAN State Manager controls the error recovery mechanism, which includes</p> <ul style="list-style-type: none"> • a reset of the CAN controller: CanIf_SetControllerMode(..., CANSM_CS_STARTED) • disabling/enabling the transmit path: CanIf_SetPduMode(..., CANIF_SET_TX_OFFLINE/CANIF_SET_TX_ONLINE)

5.2.1.2.5 Communication Manager

Detection	Notified by ComM_BusSM_ModeIndication when the Bus Off is confirmed or recovered (see CAN State Manager above)
Reaction	N/A
Report	Propagate the indicated state to the users (through the RTE)
Recovery	N/A

5.2.1.2.6 BSW State Manager

Detection	Notified by BswM_CanSM_RequestMode when the Bus Off is confirmed or recovered (see CAN State Manager above)
Reaction	not standardized
Report	not standardized
Recovery	N/A

5.2.2 CAN Controller Hardware Timeout

5.2.2.1 Summary

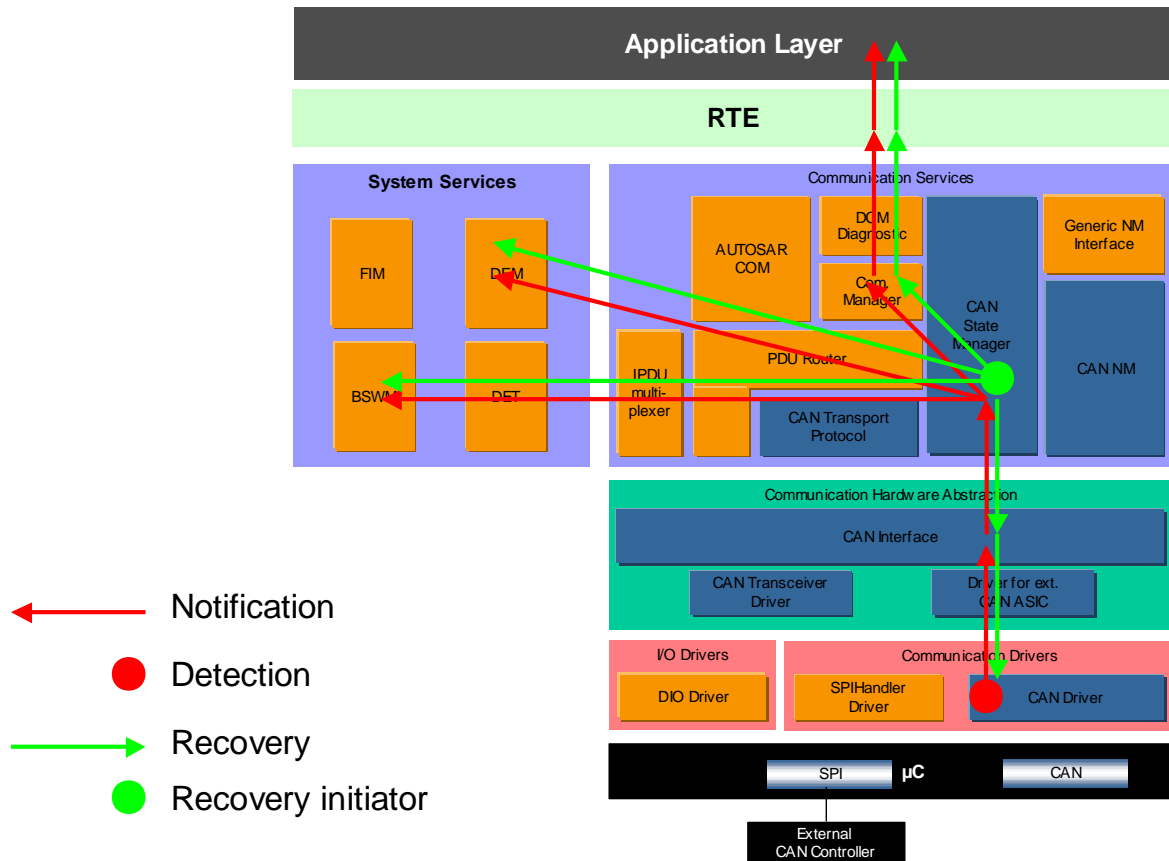

Figure 4: Information path for the CAN Controller Hardware Timeout

5.2.2.2 Roles of the modules

5.2.2.2.1 CAN Driver

Detection	The CAN driver is responsible for the detection of timeout (or defective hardware) in: <ul style="list-style-type: none"> • Can_Init [CAN176] • Can_InitController [CAN192] • Can_SetControllerMode [CAN201] • Can_DisableControllerInterrupts [CAN292] • Can_EnableControllerInterrupts [CAN293] The detection is performed by <code>Can_Mainfunction_Timeout</code> .
Reaction	[CAN380] The driver transitions to <code>CANIF_CS_STOPPED</code> [CAN381] Try to cancel pending messages
Report	[SWS_Can_00373] The error is reported to the CAN Interface by the <code>CanIf_ControllerTimeout (controller)</code> API.

Recovery	See CAN State Manager.
-----------------	------------------------

5.2.2.2.2 CAN Interface

Detection	Notified by <code>CanIf_ControllerTimeout(controller)</code> (see CAN Driver above)
Reaction	The controller operation mode is set to <code>CANIF_CS_STOPPED</code>
Report	The error is reported to the CAN State Manager by the <code>CanSm_ControllerTimeout(controller)</code>
Recovery	The recovery is triggered by the CAN State Manager: <ul style="list-style-type: none"> • <code>CanIf_SetControllerMode(Controller, CANIF_CS_STARTED)</code>. • <code>Can_InitController(Controller, *Config)</code>. • <code>Can_SetControllerMode(Controller, CAN_T_STARTED)</code>.

5.2.2.2.3 CAN State Manager

Detection	Notified by <code>CanSm_ControllerTimeout(controller)</code> (see CAN Interface above)
Reaction	<ul style="list-style-type: none"> • Count the controller timeout events • Start the error recovery mechanism
Report	<ul style="list-style-type: none"> • [CANSM319, CANSM322] If the error is confirmed, it is reported to the DEM. If the recovery succeeds, the event is cleared from the DEM. • [CANSM334] The DEM event for this error is configured per CAN network in the <code>CANSM_E_CONTROLLER_TIMEOUT</code> configuration • [CANSM325, CANSM330, CANSM331] CANSM informs the Communication Manager about the communication status (<code>COMM_SILENT_COMMUNICATION</code>, <code>COMM_NO_COMMUNICATION</code>, <code>COMM_FULL_COMMUNICATION</code>, notified with <code>ComM_BusSM_ModeIndication</code>) • [CANSM357] CANSM informs the BSW State Manager of the BusOff event. • [CANSM358, CANSM359] CANSM informs the BSW State Manager about the request to change the Communication mode (with <code>BswM_CanSM_RequestMode</code>)
Recovery	[CANSM317] The CAN State Manager controls the error recovery mechanism, which includes <ul style="list-style-type: none"> • a reset of the CAN controller: <code>CanIf_SetControllerMode(..., CANSM_CS_STARTED)</code> • disabling/enabling the transmit path: <code>CanIf_SetPduMode(..., CANIF_SET_TX_OFFLINE/CANIF_SET_TX_ONLINE)</code>

5.2.2.2.4 Communication Manager

Detection	Notified by <code>ComM_BusSM_ModeIndication</code> when the Bus Off is confirmed or recovered (see CAN State Manager above)
Reaction	N/A
Report	Propagate the indicated state to the users (through the RTE)
Recovery	N/A

5.2.2.2.5 BSW State Manager

Detection	Notified by <code>BswM_CanSM_RequestMode</code> when the Bus Off is confirmed or recovered (see CAN State Manager above)
Reaction	not standardized
Report	not standardized
Recovery	N/A

5.3 Signal error

5.3.1 CAN Transmission buffer full

5.3.1.1 Summary

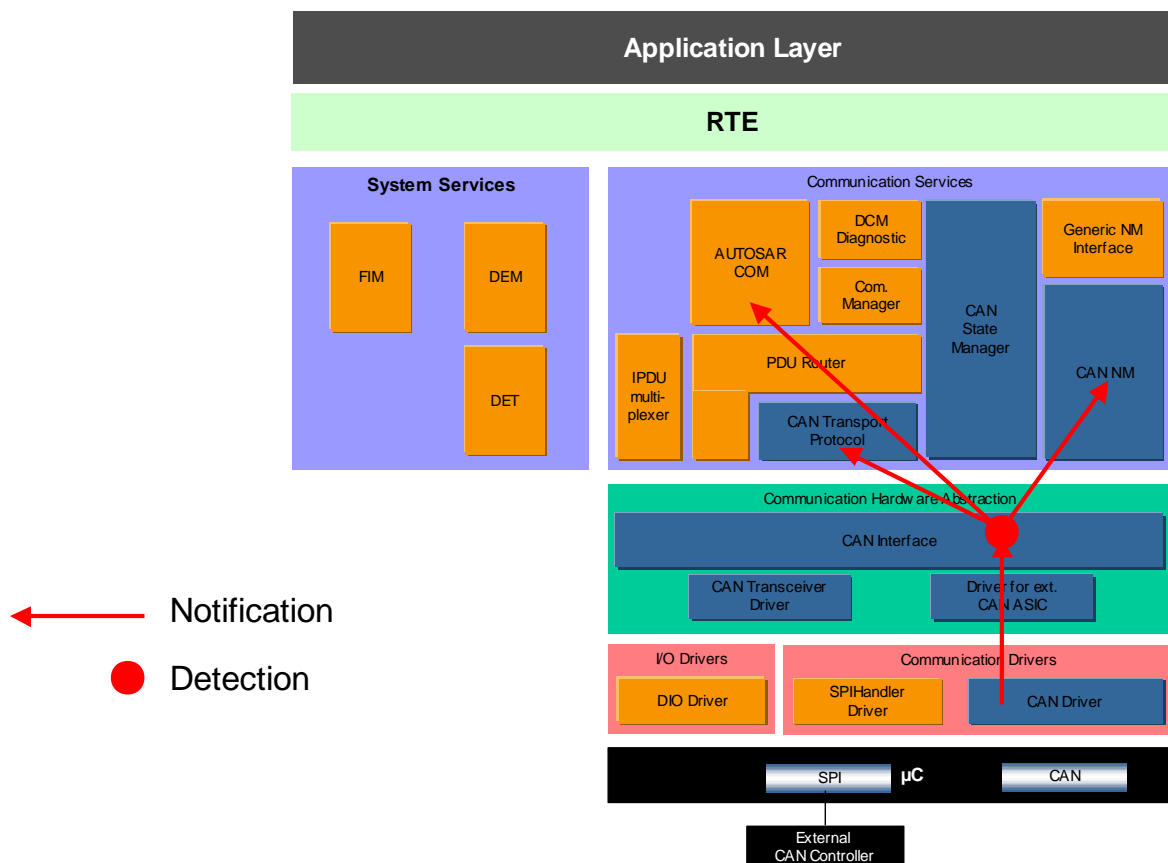

Figure 5: Information path for the CAN transmission buffer full

Note: this mechanism can be used in combination with the COM TX Deadline Monitoring or CAN Transport Protocol error during transmission mechanisms.

5.3.1.2 Roles of the modules

5.3.1.2.1 CAN Driver

Detection	A Write request is received when there are no more available HW object for this transmission, and other transmission cannot be preempted.
------------------	---

	<ul style="list-style-type: none"> Can_Write [SWS_Can_00233], [SWS_Can_00213], [SWS_Can_00215], [SWS_Can_00214], [SWS_Can_00039]
Reaction	N/A
Report	The CAN driver informs the CAN Interface that it is currently busy with an higher priority message or cannot be preempted, and cannot send a new message currently
Recovery	N/A

5.3.1.2.2 CAN Interface

Detection	<p>Transmit buffering can be enabled or disabled:</p> <ul style="list-style-type: none"> Transmit buffering disabled: if a transmit request fails, then the L-PDUs to be transmitted are lost and the API CanIf_Transmit() returns the value E_NOT_OK. [SWS_CanIf_00068] If the function CanIf_Transmit() is called and if the CanIf has to store the L-PDU in the transmit L-PDU buffer, then if the corresponding CanIfTxBuffer is already filled, the CanIf shall overwrite the older L-PDU with the recent L-PDU.
Reaction	N/A
Report	The error is either reported by the return code of CanIf_Transmit() or indirectly by the lack or transmission confirmation afterwards.
Recovery	N/A

See also the COM TX Deadline Monitoring, which provide a mechanism to detect and react (from SWC) in case of such an error.

This error may also impact a TP (Transport Protocol) communication; in that case, this will be detected as a CAN Transport Protocol error during transmission.

5.3.2 CAN Reception DLC error

5.3.2.1 Summary

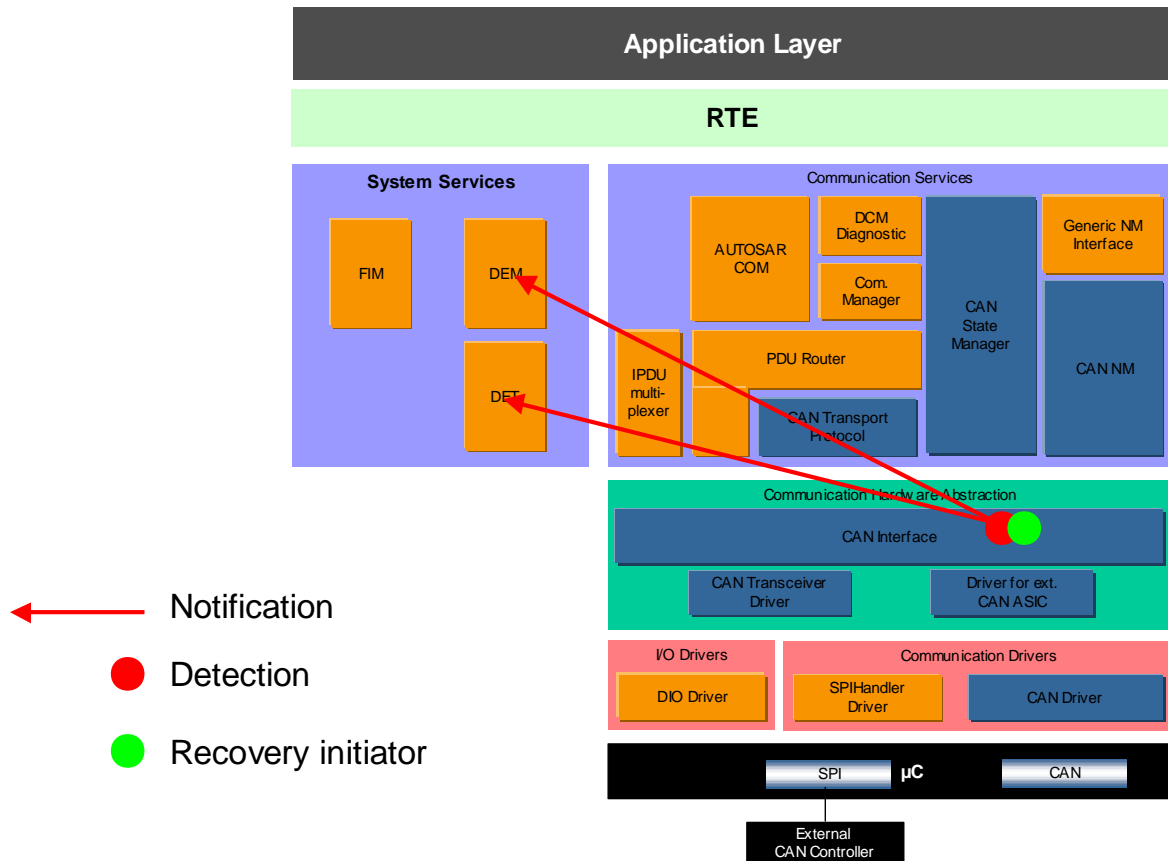

Figure 6: Information path for the CAN reception DLC error

Note: the CAN Reception DLC error mechanism can be used in combination with the COM RX Deadline Monitoring mechanism.

Also, the reception of a wrong DLC does not necessarily indicate a malfunction in the ECU, but can be caused by the ECU’s environment.

5.3.2.2 Roles of the modules

5.3.2.2.1 CAN Interface

Detection	<ul style="list-style-type: none"> [SWS_CanIf_00026] (CanIf_RxIndication) The CAN Interface is responsible for checking the length when a receive indication is triggered. This check occurs only in development mode or in production mode if the module is configured with the DLC check feature and the PDU is configured with a non-null DLC.
Reaction	N/A

Report	<p>SWS_CanIf_00168: If the DLC check fails, only the DEM shall be notified. Other upper layers are not informed. No receive indication is executed.</p> <p>Note: this DEM event cannot be used during run-time to build a reaction for this error case because it does not differentiate different communication channels. Error reactions should be based on the COM RX Deadline Monitoring mechanism.</p> <p>SWS_CanIf_00006: Invalid values of CanDlc [for the CanIf_RxIndication API] will be reported to the DET (CANIF_E_PARAM_DLC)</p>
Recovery	[SWS_CanIf_00168] No receive indication is executed

See also the COM RX Deadline Monitoring, which provide a mechanism to detect and react (from SWC) in case of such an error.

This error may also affect the CAN Transport or Network Management protocols; in these cases, the error will also be detected by the CAN Transport Protocol error during reception mechanism or by the Network Management protocol.

5.3.3 COM RX Deadline Monitoring

5.3.3.1 Summary

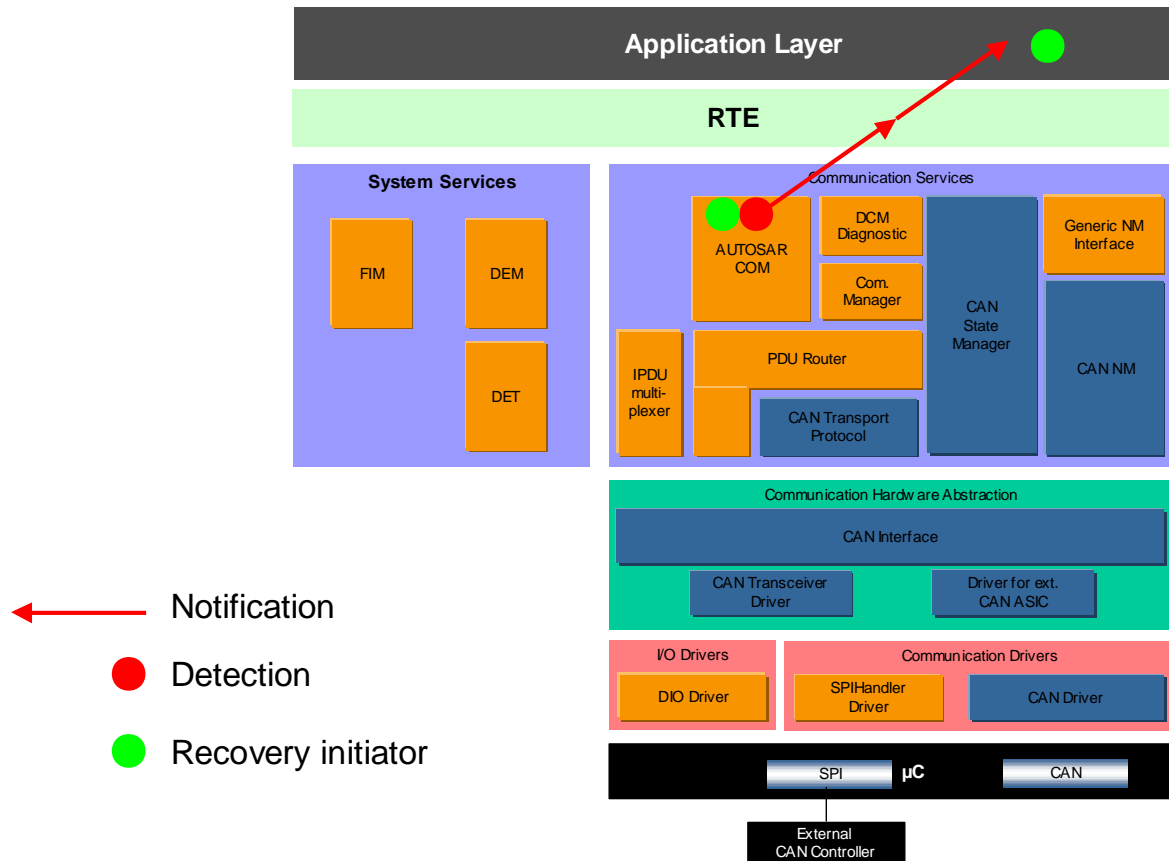

Figure 7: Information path for the COM reception deadline monitoring

5.3.3.2 Roles of the modules

5.3.3.2.1 AUTOSAR COM

Detection	[COM292] If configured, AUTOSAR COM will notice the failure because no signals were received for a given period of time
Reaction	[COM393] AUTOSAR COM can replace the value with a default value or keep the previous value.
Report	[COM556] The upper layer (RTE) is notified by Com_CbkRxTOut
Recovery	[COM393] AUTOSAR COM can replace the value with a default value or keep the previous value.

5.3.3.2.2 RTE

Detection	The RTE is notified by AUTOSAR COM by Rte_COMCbktOut_<sn>
------------------	---

	(or Rte_COMCbktOut_<sg>). (see AUTOSAR COM above)
Reaction	N/A
Report	The RTE informs the SWC with a DataReceiveErrorEvent.
Recovery	See AUTOSAR COM and SWC .

5.3.3.2.3 SWC

Detection	The SWC is notified by the RTE (DataReceiveErrorEvent), the status of the transmission is requested with an Rte_Feedback API. (see RTE above)
Reaction	The SWC can decide to re-send the signals or ignore the error.
Report	N/A
Recovery	The SWC can decide to re-send the signals.

5.3.4 COM TX Deadline Monitoring

5.3.4.1 Summary

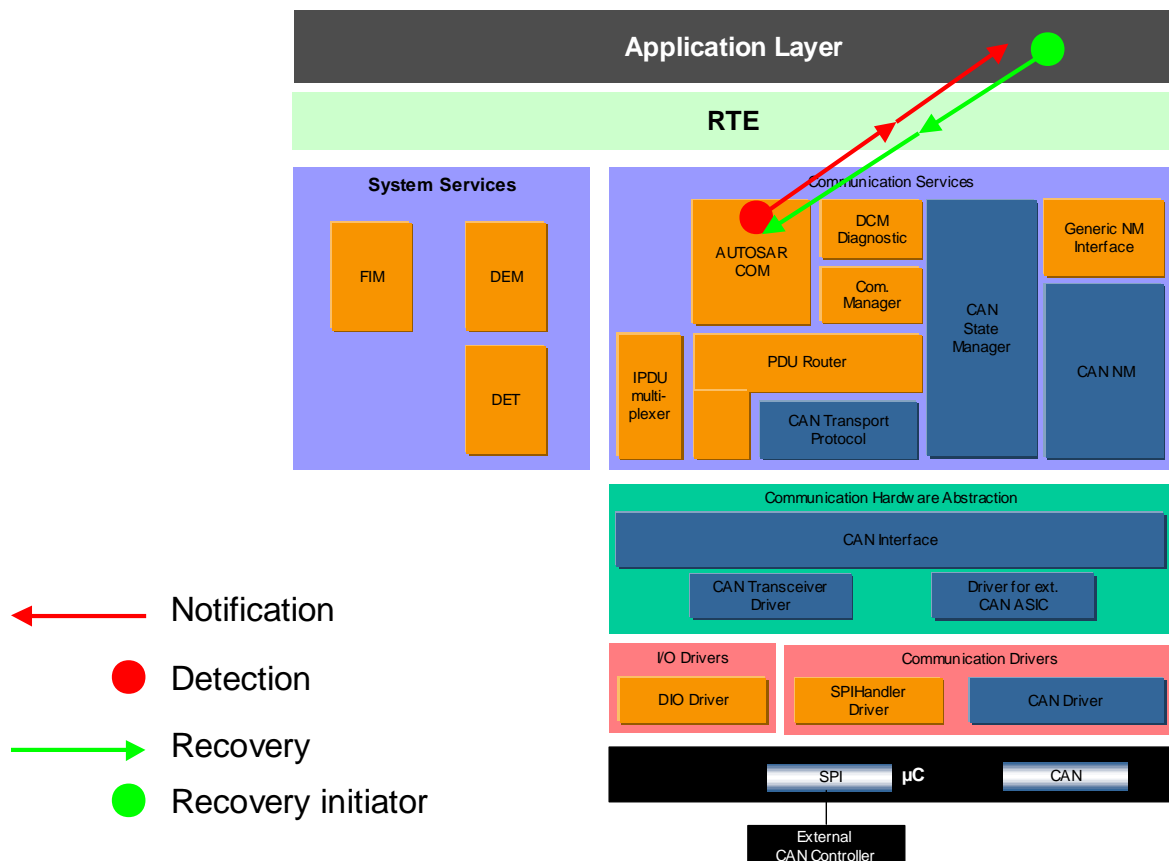

Figure 8: Information path for the COM transmission deadline monitoring

This feature should only be used if the lower layer communication modules provide confirmation for the transmissions.

5.3.4.2 Roles of the modules

5.3.4.2.1 AUTOSAR COM

Detection	[COM304] If the transmission deadline monitoring is configured, AUTOSAR COM will notice a timeout after the deadline for transmission is elapsed, if the lower layer modules do not confirm the transmission.
Reaction	N/A
Report	[COM554] The upper layer (RTE) is notified by Com_CbkTxTOut
Recovery	See SWC .

5.3.4.2.2 RTE

Detection	The RTE is notified by AUTOSAR COM with: [rte sws 3775] Rte_COMCbKTErr_<sn> (or Rte_COMCbKTOut_<sn>?)
Reaction	N/A
Report	The RTE informs the SWC with a DataSendCompletedEvent, and provides the status with an Rte_Feedback API.
Recovery	See SWC .

5.3.4.2.3 SWC

Detection	The SWC is notified by the RTE (DataSendCompletedEvent), the status of the transmission is requested with an Rte_Feedback API.
Reaction	The SWC can decide to re-send the signals, log or ignore the error.
Report	N/A
Recovery	The SWC can decide to re-send the signals.

5.3.5 CAN Transport Protocol error during transmission

This use case is a functionality of the Transport Protocol, and is defined in the functional behavior of the CANTP module. It is mentioned here for completeness of the use cases where a CAN frame fails to be transmitted.

The analysis below only takes into account a timeout error in the CANTP protocol, but the behavior will be the same for other busses or other transport protocol errors.

5.3.5.1 Summary

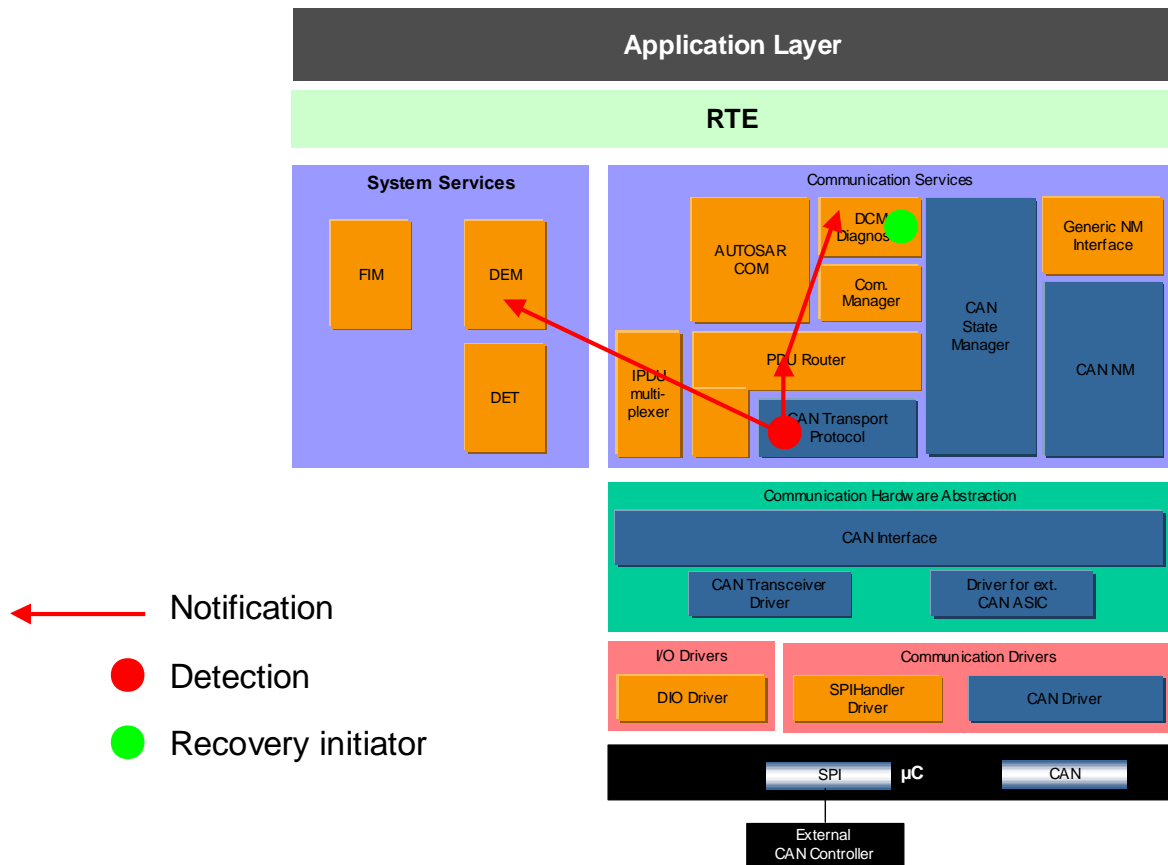

Figure 9: Information path for the CAN Transport Protocols errors during transmission

Note: In the figure above, the DCM represents the CANTP user. Other users of CANTP should react similarly (they will receive the indication of failures, and are responsible for initiating a recovery). Another user could be a SWC, with the communication routed to AUTOSAR COM by the PDU Router, or a Complex Driver.

5.3.5.2 Roles of the modules

5.3.5.2.1 CANTP

Detection	The CANTP module implement the CAN Transport Layer protocol, and is responsible to detect any timeout during a transmission.
Reaction	[SWS_CanTp_00205] If a timeout is detected, the transmission is cancelled. The module is ready to process another transmission request.
Report	[SWS_CanTp_00229] Any error is reported to the DEM (event CANTP_E_COM), with the DEM_EVENT_STATUS_PREFAILED status. Note: this DEM event cannot be used during run-time to build a reaction for this error case because it does not differentiate different error cases or different communication channels.

	[SWS_CanTp_00205] The error is also reported to the user of the CANTP (for example, the DCM through the PDUR) with the PduR_CanTpTxConfirmation.
Recovery	N/A

5.3.5.2.2 PDUR

Detection	The PDUR is informed via the PduR_CanTpTxConfirmation API. (see CANTP above)
Reaction	N/A
Report	The error is routed to the CANTP user (Dcm_TxConfirmation)
Recovery	N/A

5.3.5.2.3 DCM

Detection	[SWS_Dcm_00351] The DCM is informed with the Dcm_TxConfirmation Result parameter (see PDUR above). There is also an internal timeout handler for diagnostic sessions.
Reaction	[SWS_Dcm_00351] Transmission resources (transmit buffer) are unlocked. And other error handling features (timeout in the DCM) are cancelled.
Report	The user is informed with the ConfirmationRespPend operation.
Recovery	N/A

Note: Other users of CANTP should provide a similar notification callout and should react similarly. This is for example the case of the AUTOSAR COM module.

5.3.6 CAN Transport Protocol error during reception

5.3.6.1 Summary

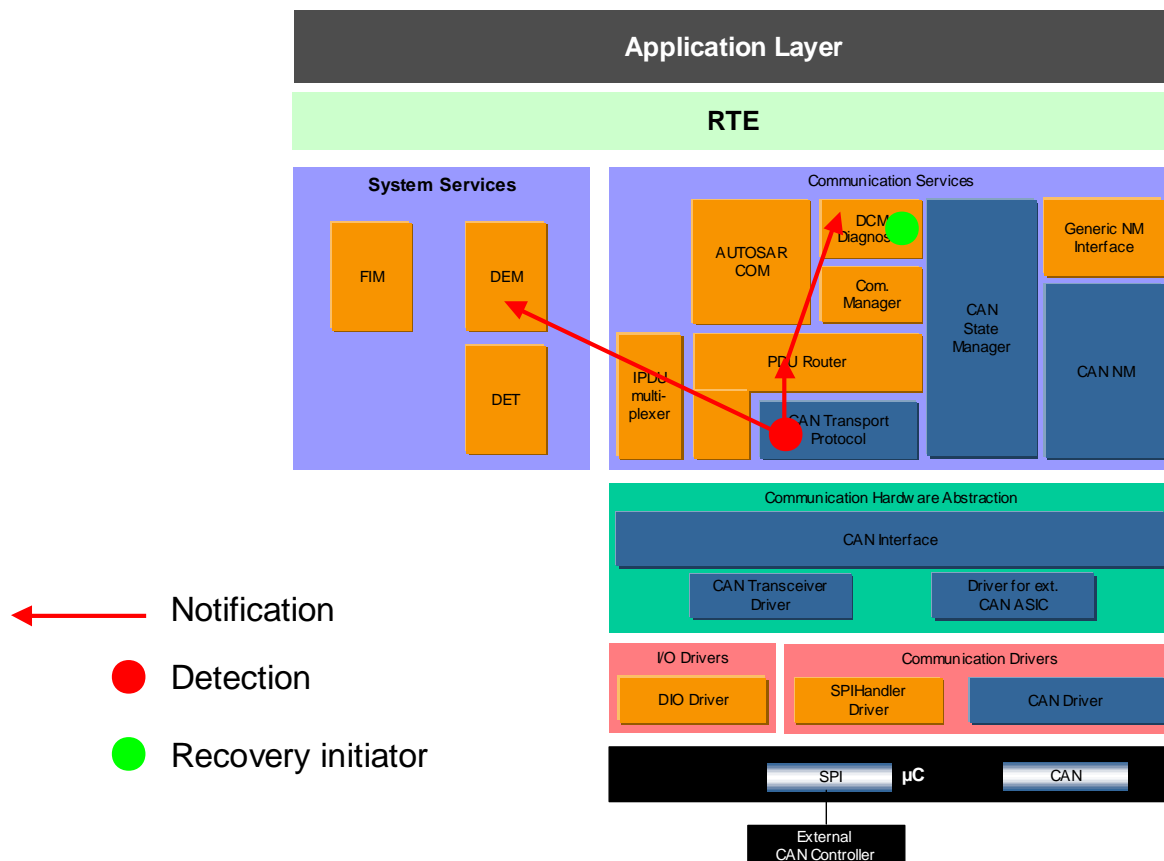

Figure 10: Information path for the CAN Transport Protocols errors during reception

Note: In the figure above, the DCM represent the CANTP user. Other users of CANTP should react similarly (they will receive the indication of failures, and are responsible for initiating a recovery). Another user could be a SWC, with the communication routed to AUTOSAR COM by the PDU Router, or a Complex Driver.

5.3.6.2 Roles of the modules

5.3.6.2.1 CANTP

Detection	The CANTP module implement the CAN Transport Layer protocol, and is responsible to detect any timeout during a reception.
Reaction	[SWS_CanTp_00205] If a timeout is detected, the reception is cancelled.
Report	[SWS_CanTp_00229] Any error is reported to the DEM (event CANTP_E_COM), with the DEM_EVENT_STATUS_PREFAILED status.

	<p>Note: this DEM event cannot be used to build a reaction for this error case because it does not differentiate different error cases or different communication channels.</p> <p>[SWS_CanTp_00205] The error is also reported to the user of the CANTP (for example, the DCM through the PDUR) with the PduR_CanTpRxIndication.</p>
Recovery	N/A

5.3.6.2.2 PDUR

Detection	The PDUR is informed via the PduR_CanTpRxIndication API (see CANTP above).
Reaction	N/A
Report	The error is routed to the CANTP user (for example, Dcm_RxIndication)
Recovery	N/A

5.3.6.2.3 DCM

Detection	The DCM is informed with the Dcm_RxIndication Result parameter. There is also an internal timeout handler for diagnostic sessions.
Reaction	Reception resources (receive buffer) are unlocked.
Report	N/A
Recovery	N/A

Note: Other users of CANTP should provide a similar notification callout and should react similarly. This is for example the case of the AUTOSAR COM module.

5.3.7 CANNM TX Deadline Monitoring

This use case is not really an error. It is a functionality of the Network Management, and is defined in the functional behavior of the CANNM module. It is mentioned here for completion of the use cases where a CAN frame fails to be transmitted.

5.3.8 PDU replication error

5.3.8.1 Summary

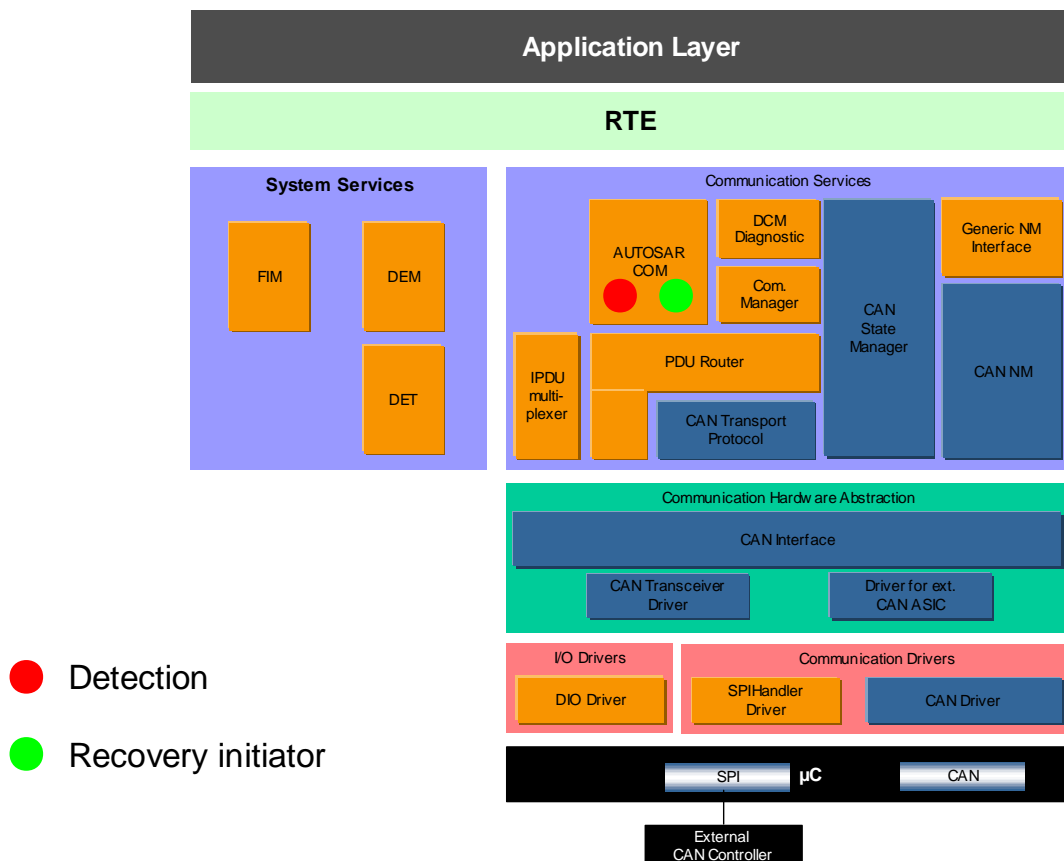

Figure 11: Information path for the PDU replication error

This mechanism is internal to the AUTOSAR COM module. No notifications exist specifically for this error.

Note: the PDU replication error mechanism can be used in combination with the COM RX Deadline Monitoring mechanism.

5.3.8.2 Roles of the modules

5.3.8.2.1 AUTOSAR COM

Detection	The detection is indirect since only voted signals or signal groups are reported to the RTE. <ul style="list-style-type: none"> Other PDU are discarded and may result in a detection by the COM RX Deadline Monitoring mechanism.
Reaction	[COM596] The PDU is reported to the RTE only after reception of a quorum of identical values. [COM597] signals and signal groups are reported only once to the RTE

Report	N/A
Recovery	If enough copies are received for a PDU, the voted PDU is reported to the RTE.

5.3.9 PDU counter error

5.3.9.1 Summary

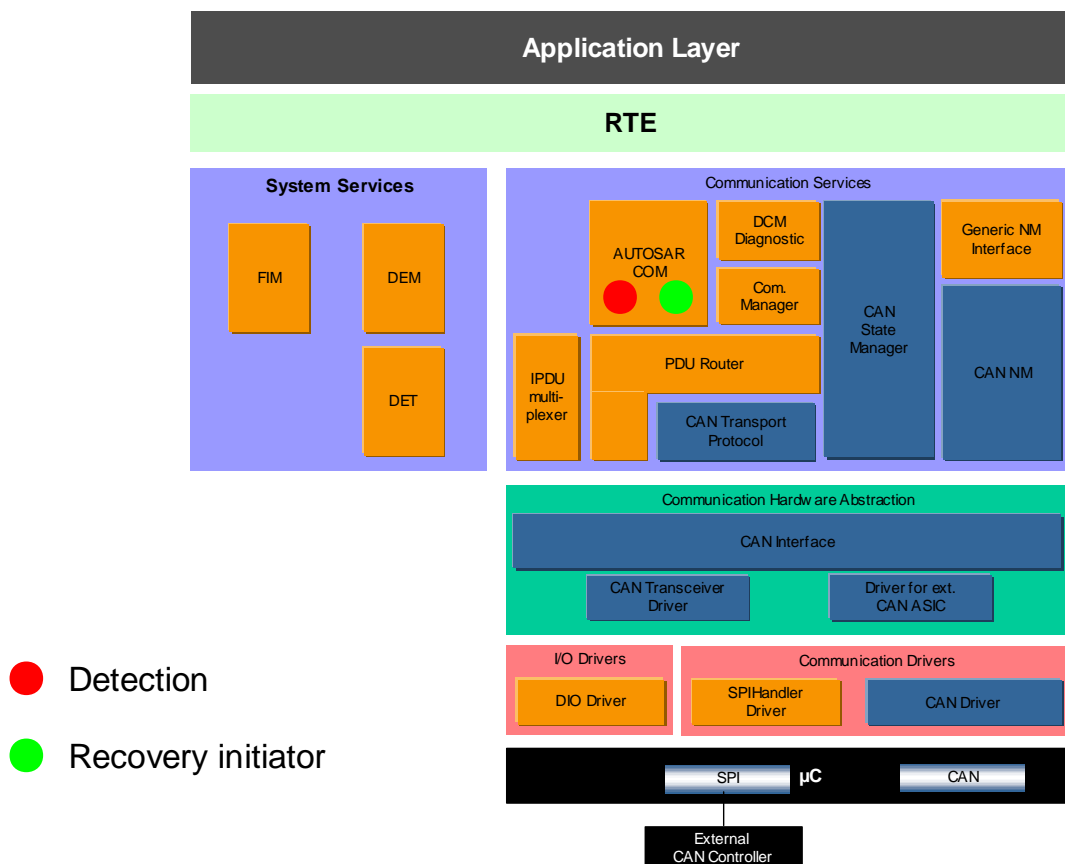

Figure 12: Information path for the PDU counter error

This mechanism is internal to the AUTOSAR COM module. No notifications exist specifically for this error.

Note: the PDU counter error mechanism can be used in combination with the COM RX Deadline Monitoring mechanism.

5.3.9.2 Roles of the modules

5.3.9.2.1 AUTOSAR COM

Detection	The AUTOSAR COM module is responsible for the detection of out of sequence PDUs
Reaction	[COM590] If the PDU counter of the received PDU does not match the

	expected one (within the defined threshold margin), the PDU is discarded.
Report	N/A
Recovery	This mechanisms does not introduce new mechanisms: as a result of a dropped PDU, an RX timeout may be detected.

5.3.10 Client / Server timeout

5.3.10.1 Summary

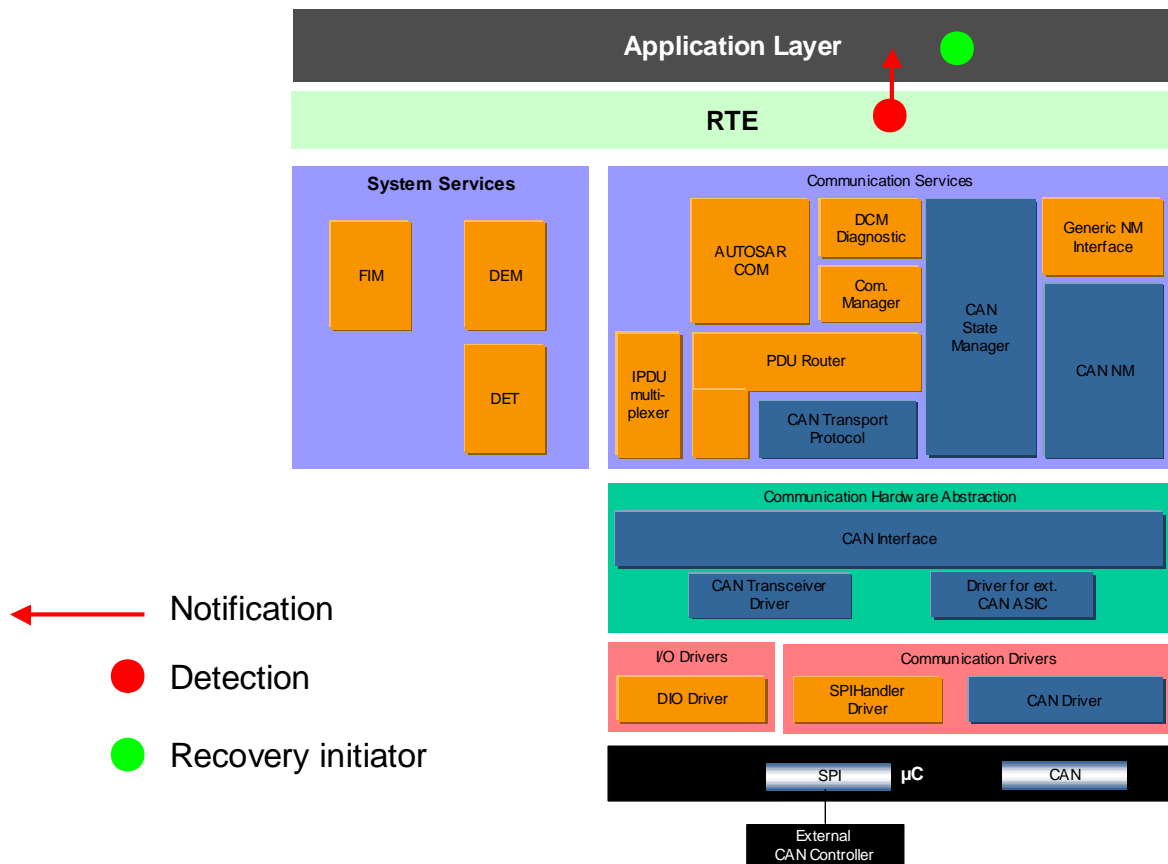

Figure 13: Information path for the client / server timeout

5.3.10.2 Roles of the modules

5.3.10.2.1 RTE

Detection	[SWS_Rte_3763] If configured, the RTE is responsible for the detection of timeouts. (Note that there are some exception for local inter-ECU communication where timeout are not taken into account)
Reaction	N/A

Report	[SWS_Rte_1107, SWS_Rte_1114] The RTE informs the SWC with a <code>AsynchronousServerCallReturnsEvent</code> , and provides the status with an <code>Rte_Call</code> or <code>Rte_Result</code> API.
Recovery	See SWC.

5.3.10.2.2 SWC

Detection	The SWC is notified by the RTE (<code>DataSendCompletedEvent</code>), the status of the transmission is returned with the <code>Rte_Call</code> or <code>Rte_Result</code> API.
Reaction	The SWC can decide to re-send the request, log or ignore the error.
Report	N/A
Recovery	The SWC can decide to re-send the request.

6 NVRAM related errors

6.1 Overview

6.1.1 Error handling mechanisms

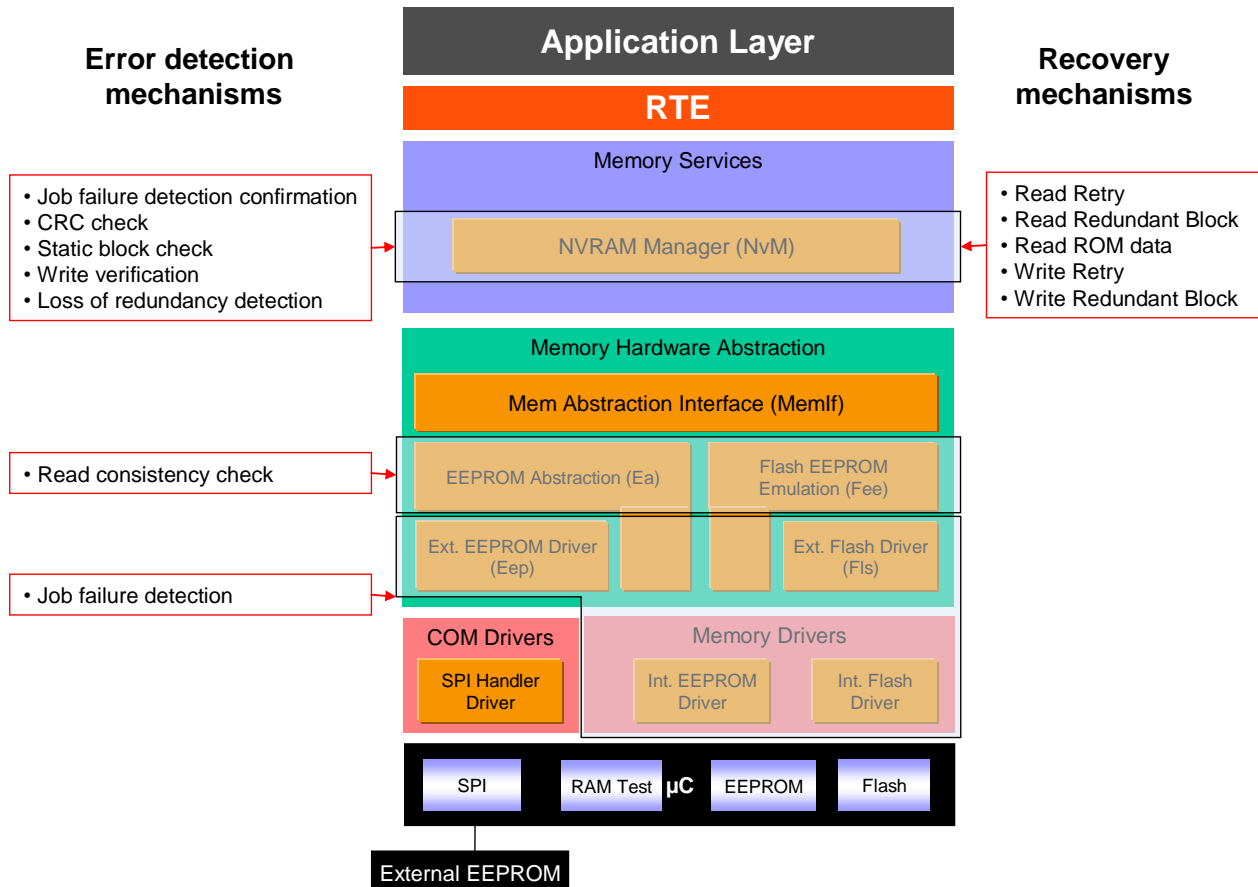

Figure 14: NVRAM Error Handling Mechanisms Overview

On the lower levels of the NVRAM stack, mechanisms are implemented in the drivers to detect hardware access problems. Detection mechanisms are harmonized between EEPROM and Flash drivers.

On the upper layers of the NVRAM stack (mainly in the NVRAM manager), mechanisms are implemented to detect data corruption, memory address corruption and loss of redundancy. All the recovery mechanisms for the detected errors in the NVRAM stack are handled by the NVRAM Manager.

The error can be reported in polling or interrupt mode. The whole memory stack must be configured consistently with the usage done by SWC and BSW users.

6.1.2 Error list for NVRAM stack

Error	Description	Detection module	DEM error (reporter in bold)	Mitigator with BSW recovery actions
Driver level errors				
Flash write job error	The flash write job failed due to a hardware error.	FLS	FLS_E_WRITE_FAILED	NVM : → Write Retry
Flash erase job error	The flash erase job failed due to a hardware error.	FLS	FLS_E_ERASE_FAILED	NVM : → Write Retry if write processing involved
Flash read job error	The flash read job failed due to a hardware error.	FLS	FLS_E_READ_FAILED	NVM : → Read Retry → Read Redundant Block → Read ROM block
Flash compare job error	The flash compare job failed due to a hardware error.	FLS	FLS_E_COMPARE_FAILED	None
External Flash Hardware ID Mismatch	Expected hardware ID not matched during initialization of the driver.	FLS	FLS_E_UNEXPECTED_FLASH_ID	None
EEPROM write job error	The EEPROM write job failed due to a hardware error.	EEP	EEP_E_WRITE_FAILED	NVM : → Write Retry
EEPROM erase job error	The EEPROM erase job failed due to a hardware error.	EEP	EEP_E_ERASE_FAILED	NVM : → Write Retry if write processing involved
EEPROM read job error	The EEPROM read job failed due to a hardware error.	EEP	EEP_E_READ_FAILED	NVM : → Read Retry → Read Redundant Block → Read ROM block
EEPROM compare job error	The EEPROM compare job failed due to a hardware error.	EEP	EEP_E_COMPARE_FAILED	None
EEPROM Abstraction / Flash Emulation level errors				
FEE consistency check error	The Flash Eeprom Emulation detects a problem of consistency in the block to read.	FEE	NVM_E_INTEGRITY_FAILURE	NVM : → Read Redundant Block → Read ROM block
EA consistency check error	The Eeprom Abstraction emulation detects a problem of consistency in the block to read.	EA	NVM_E_INTEGRITY_FAILURE	NVM : → Read Redundant Block → Read ROM block
NVRAM Manager level errors				

Error	Description	Detection module	DEM error (reporter in bold)	Mitigator with BSW recovery actions
NVM CRC Check	The CRC check on the RAM block failed.	NVM	NVM_E_INTEGRITY_FAILED	NVM : → Read Redundant Block → Read ROM block
NVM Write verification error	The NVRAM Block written to NVRAM is immediately read back and compared with the original content in RAM.	NVM	NVM_E_VERIFY_FAILED	NVM : → Write Retry
Static Block check Error	Static Block ID Check failed	NVM	NVM_E_WRONG_BLOCK_ID	NVM : → Read Retry → Read Redundant Block → Read ROM block
Loss of redundancy	Redundant block invalid during reading or writing.	NVM	NVM_E_LOSS_OF_REDUNDANCY	NVM : → Recovery of the corrupted NV Block.
NVM API request failure	Job failure is confirmed after recovery failure.	NVM	NVM_E_REQ_FAILED	None

Table 4: NVRAM stack error list

6.1.3 Mappings of EH mechanisms to NVRAM hardware failure modes

The following NVRAM hardware failure modes have been considered:

ID	Short name	Description
FM01	No access	The memory device cannot be accessed.
FM02	Read corrupt data	Data read from the memory is corrupted i.e. not as intended.
FM03	Read from incorrect address	The cells at the intended address are not read. The values from other cells are obtained instead.
FM04	Write corrupt data	Data written into the memory is corrupted by the memory device i.e. stored data is not as intended.
FM05	Write to incorrect address	The cells at the intended address are not written to. The values of other cells are overwritten instead.

Table 5: NVRAM hardware failures modes

The tables below show error handling mechanisms relevant for each FM and a qualitative estimation of the efficiency of the mechanisms. The qualitative measure is defined by:

- A – Full coverage for the considered FM

- P – Partial coverage for the considered FM
- N – No coverage for the considered FM

ID	Failure Mode	Description	Job Failure Detection	CRC Check	Static Block ID Check	Write Verification
FM01	No access	The memory device cannot be accessed.	A	N	N	N
FM02	Read corrupt data	Data read from the memory is corrupted i.e. not as intended.	N	P	N	N
FM03	Read from incorrect address	The cells at the intended address are not read. The values from other cells are obtained instead.	N	P	P	N
FM04	Write corrupt data	Data written into the memory is corrupted by the memory device i.e. stored data is not as intended.	N	N	N	A
FM05	Write to incorrect address	The cells at the intended address are not written to. The values of other cells are overwritten instead.	N	N	N	P

Table 6: Mappings of detection mechanisms to failure modes

ID	Failure Mode	Description	Read Retry ⁽¹⁾	Read Redundant Block	Read ROM data	Write Retry	Write Redundant Block
FM01	No access	The memory device cannot be accessed.	P	N	P	P	N
FM02	Read corrupt data	Data read from the memory is corrupted i.e. not as intended.	P	P	P	N	N
FM03	Read from incorrect address	The cells at the intended address are not read. The values from other cells are obtained instead.	P	P	P	N	N
FM04	Write corrupt data	Data written into the memory is corrupted by the memory device i.e. stored data is not as intended.	N	N	N	P	P
FM05	Write to incorrect address	The cells at the intended address are not written to. The values of other cells are overwritten instead.	N	N	N	P	P

Table 7: Mappings of recovery mechanisms to failure modes

(1) For transient errors

6.2 Driver level errors

6.2.1 Flash write job error

6.2.1.1 Summary

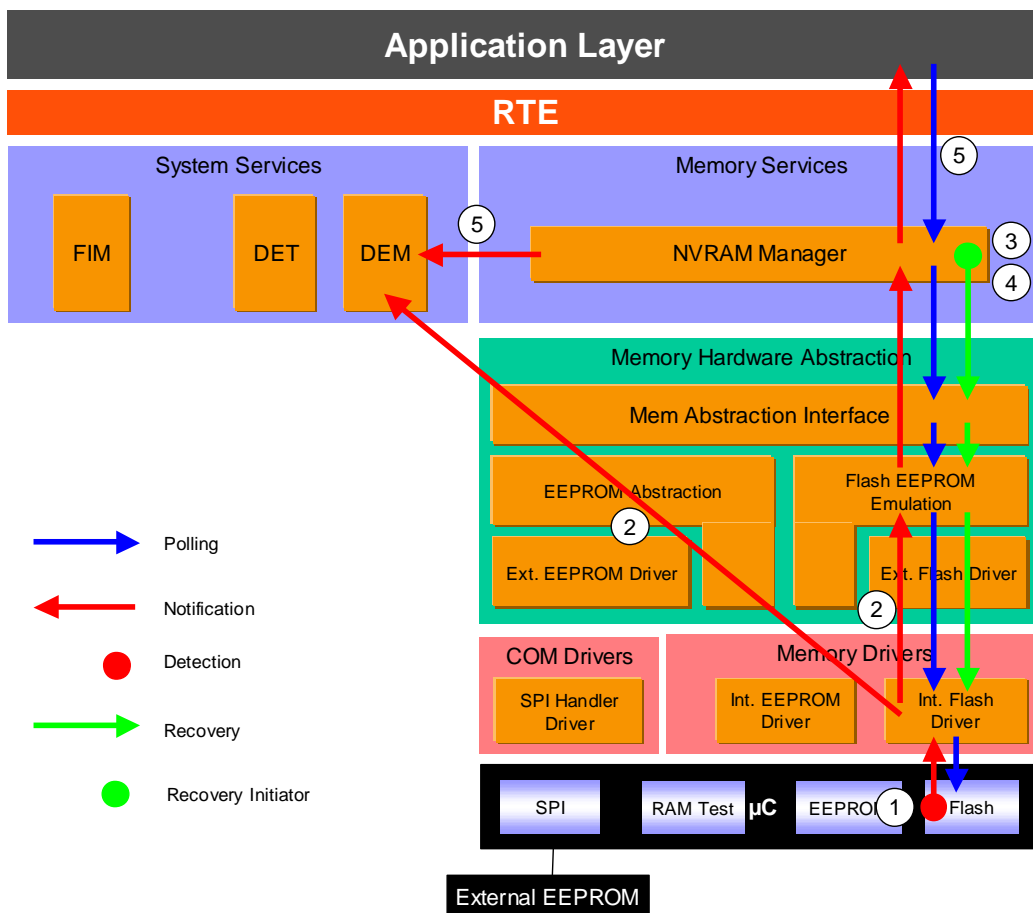

Figure 15: Information path for the Flash write job error (for internal flash)

Write job error is detected by HW (①). Flash Driver is the first SW module involved, and is responsible for the report to the DEM and to upper layers (②). Upper layers have to reset some internal states in order to accept new requests. A recovery mechanism is present in the NVM module which permits to retry a write job in case of failure (③). If the recovery also fails (④), the NVRAM manager reports NVM_E_REQ_FAILED error to the DEM and sets the job result to NOK (⑤), see [NVM API request failure](#).

6.2.1.2 Roles of the modules

6.2.1.2.1 Flash controller

Detection	HW dependent
Reaction	N/A
Report	Depending on the Driver configuration or HW implementation, the error can be reported in a register or the controller can report the error to the driver with an interrupt.
Recovery	See NVRAM Manager .

6.2.1.2.2 Flash driver

Detection	Reported by the Flash controller (see Flash controller above).
Reaction	<ul style="list-style-type: none"> [SWS_Fls_00105] The job is aborted. [FLS052] The module state is set to MEMIF_IDLE, ready to accept new jobs.
Report	<ul style="list-style-type: none"> [SWS_Fls_00004] [SWS_Fls_00105] The error is reported to the DEM with the error code FLS_E_WRITE_FAILED. Depending on the Flash Driver configuration: <ul style="list-style-type: none"> [SWS_Fls_00105] [SWS_Fls_00035] The error shall be polled by the Flash EEPROM Emulation with the function Fls_GetJobResult (job result set to MEMIF_JOB_FAILED). [SWS_Fls_00263] [FLS168] The error shall be reported to the Flash EEPROM Emulation by the callback function Fee_JobErrorNotification.
Recovery	See NVRAM Manager .

6.2.1.2.3 Flash Eeprom emulation

Detection	Reported by the Flash Driver (see Flash driver above).
Reaction	[SWS_Fee_00054] Implementation specific error handling.
Report	Depending on the configuration: <ul style="list-style-type: none"> [SWS_Fee_00091] [SWS_Fee_00035] The error shall be polled by the Memory Abstraction Interface with the function Fee_GetJobResult (job result set to MEMIF_JOB_FAILED). [SWS_Fee_00056] [SWS_Fee_00054] The error shall be reported to the NVRAM Manager via the Callback function NvM_JobErrorNotification.
Recovery	See NVRAM Manager .

6.2.1.2.4 Memory Abstraction Interface

Detection	Reported by the Flash Eeprom Emulation (see Flash Eeprom emulation above), only if the stack is configured in polling mode
Reaction	N/A

Report	Only if the stack is configured in polling mode : <ul style="list-style-type: none"> • [MemIf043] [MemIf053] The error shall be polled by the NVRAM manager with the function MemIf_GetJobResult (job result set to MEMIF_JOB_FAILED).
Recovery	See NVRAM Manager .

6.2.1.2.5 NVRAM Manager

Detection	Depending on the stack configuration: <ul style="list-style-type: none"> • Polling of the job result MEMIF_JOB_FAILED by the function MemIf_GetJobResult (see Memory Abstraction Interface above). • Notification by FEE with the callback function NvM_JobErrorNotification (see Flash Eeprom emulation above).
Reaction	[SWS_NvM_00213] [SWS_NvM_00296] Increment write retry counter. If the number of retries is exceeded, the request is aborted.
Report	<ul style="list-style-type: none"> • [SWS_NvM_00213] [SWS_NvM_00296] If recovery actions abort, the error NVM_E_REQ_FAILED is reported to the DEM. Depending on the configuration <ul style="list-style-type: none"> • [SWS_NvM_00451] [SWS_NvM_00213] [SWS_NvM_00296] The error shall be polled by the user with the function NvM_GetErrorStatus (job result set to NVM_REQ_NOT_OK). • [SWS_NvM_00113] [SWS_NvM_00260] The error shall be reported to the user via the configurable callbacks SingleBlockCallbackFunction or MultiBlockCallbackFunction.
Recovery	[SWS_NvM_00168] [SWS_NvM_00213] [SWS_NvM_00296] The NVRAM Manager controls the error recovery mechanism. The recovery mechanism is (if configured) “write retry”.

6.2.1.2.6 Application Software Component

Detection	If necessary for the design of an error handling strategy, the SWC can be designed in two different ways: <ul style="list-style-type: none"> • it polls the job status with the GetErrorStatus operation on the client port connected to the NVM • it provides a server runnables attached to a NvMNotifyJobFinished server port which shall be invoked by the NVM. See sections <ul style="list-style-type: none"> • 13.3.1.3 Port Interface • 13.3.2 Ports and Port Interface for Notifications of Autosar_SWS_NVRAMManager.pdf
------------------	---

6.2.2 Flash erase job error

6.2.2.1 Summary

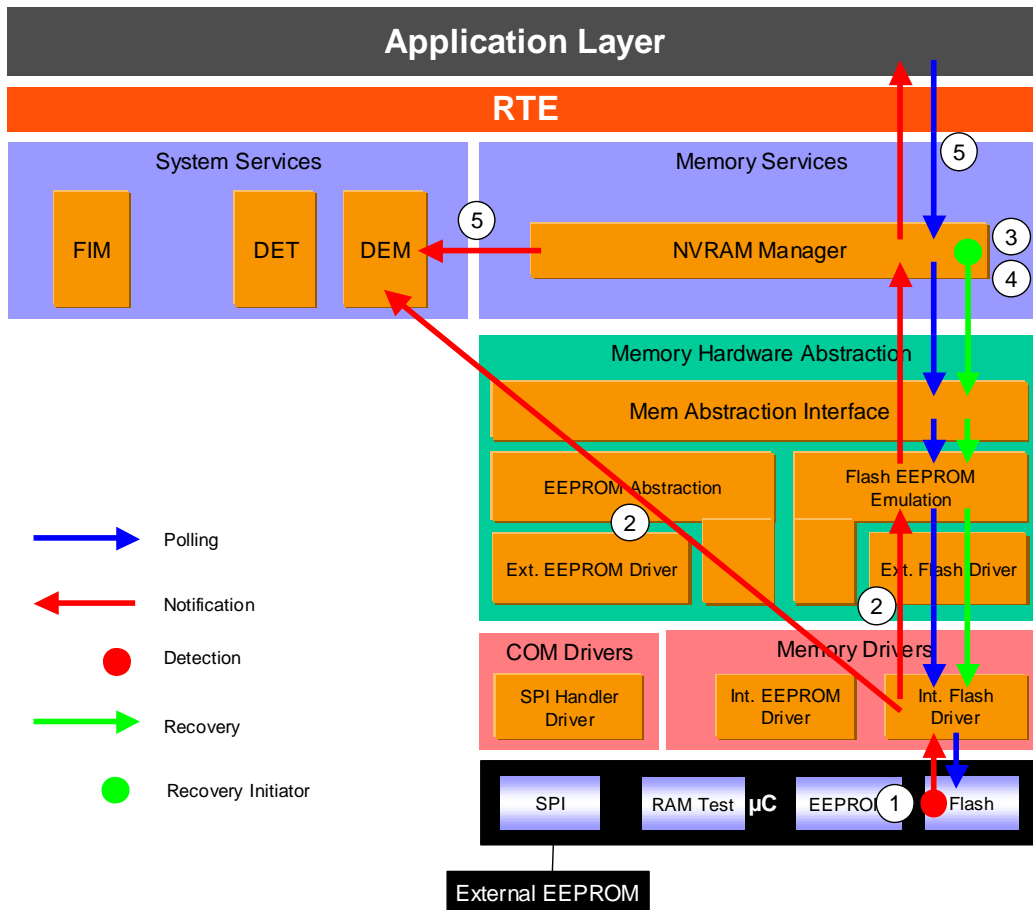

Figure 16: Information path for the flash erase job error (for internal flash)

Erase job error is detected by HW (①). Flash Driver is the first SW module involved, and is responsible for the report to the DEM and to upper layers (②). Upper layers have to reset some internal states in order to accept new requests. If the erase driver job is part of a write operation, write retries are initiated by the NVRAM manager (③) as soon as the error is reported to this layer. If the recovery also fails (④), the NVRAM manager reports NVM_E_REQ_FAILED error to the DEM and sets the job result to NOK (⑤), see [NVM API request failure](#).

6.2.2.2 Roles of the modules

6.2.2.2.1 Flash controller

Detection	HW dependent.
Reaction	N/A
Report	Depending on the Driver configuration or HW implementation, the

	error can be reported in a register or the controller can report the error to the driver with an interrupt.
Recovery	See NVRAM Manager.

6.2.2.2.2 Flash driver

Detection	Reported by the Flash controller (see Flash controller above).
Reaction	<ul style="list-style-type: none"> • [SWS_Fls_00104] The job is aborted. • [FLS052] The module state is set to MEMIF_IDLE, ready to accept new jobs.
Report	<ul style="list-style-type: none"> • [SWS_Fls_00004] [SWS_Fls_00104] The error is reported to the DEM with the error code FLS_E_ERASE_FAILED. Depending on the Flash Driver configuration: <ul style="list-style-type: none"> • [SWS_Fls_00104] [SWS_Fls_00035] The error shall be polled by the Flash EEPROM Emulation with the function Fls_GetJobResult (job result set to MEMIF_JOB_FAILED). • [SWS_Fls_00263] [FLS168] The error shall be reported to the Flash EEPROM Emulation by the callback function Fee_JobErrorNotification.
Recovery	See NVRAM Manager.

6.2.2.2.3 Flash Eeprom emulation

Detection	Reported by the Flash Driver (see Flash driver above).
Reaction	[SWS_Fee_00054] Implementation specific error handling.
Report	Depending on the configuration: <ul style="list-style-type: none"> • [SWS_Fee_00091] [SWS_Fee_00035] The error shall be polled by the Memory Abstraction Interface with the function Fee_GetJobResult (job result set to MEMIF_JOB_FAILED). • [SWS_Fee_00056] [SWS_Fee_00054] The error shall be reported to the NVRAM Manager via the Callback function NvM_JobErrorNotification.
Recovery	See NVRAM Manager.

6.2.2.2.4 Memory Abstraction Interface

Detection	Reported by the Flash Eeprom Emulation (see Flash Eeprom emulation above), only if the stack is configured in polling mode
Reaction	N/A
Report	Depending on the configuration: <ul style="list-style-type: none"> • [MemIf043] [MemIf053] The error shall be polled by the NVRAM manager with the function MemIf_GetJobResult (job result set to MEMIF_JOB_FAILED).
Recovery	See NVRAM Manager.

6.2.2.2.5 NVRAM Manager

Detection	Depending on the stack configuration: <ul style="list-style-type: none"> • Polling of the job result MEMIF_JOB_FAILED by the function MemIf_GetJobResult (see Memory Abstraction Interface above). • Notification by FEE with the callback function NvM_JobErrorNotification (see Flash Eeprom emulation above).
Reaction	If write processing involved : [SWS_NvM_00213] [SWS_NvM_00296] Increment write retry counter. If the number of retries is exceeded, the request is aborted.
Report	<ul style="list-style-type: none"> • [SWS_NvM_00271] [SWS_NvM_00269] The error NVM_E_REQ_FAILED is reported to the DEM. • The error can be available by polling the NVRAM Manager with the function NvM_GetErrorStatus (job result set to NVM_REQ_NOT_OK).
Recovery	If write processing involved : [SWS_NvM_00168] [SWS_NvM_00213] [SWS_NvM_00296] The NVRAM Manager controls the error recovery mechanism. The recovery mechanism is (if configured) “write retry”.

6.2.2.2.6 Application Software Component

Detection	<p>If necessary for the design of an error handling strategy, the SWC can be designed in two different ways:</p> <ul style="list-style-type: none"> • it polls the job status with the GetErrorStatus operation on the client port connected to the NVM • it provides a server runnables attached to a NvMNotifyJobFinished server port which shall be invoked by the NVM. <p>See sections</p> <ul style="list-style-type: none"> • 13.3.1.3 Port Interface • 13.3.2 Ports and Port Interface for Notifications of Autosar_SWS_NVRAMManager.pdf
------------------	---

6.2.3 Flash read job error

6.2.3.1 Summary

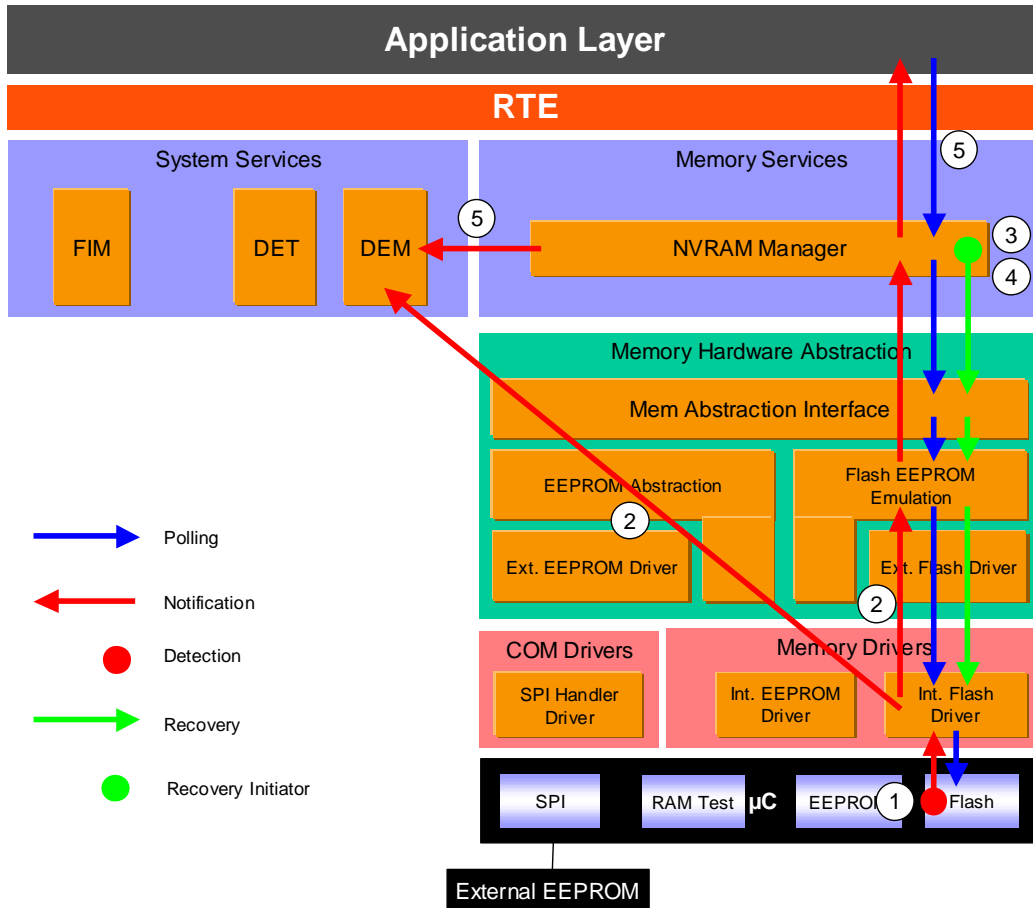

Figure 17: Information path for the flash read job error (internal flash)

Read job error is detected by HW. Flash Driver is the first SW module involved, and is responsible for the report to the DEM and to upper layers (②). Upper layers have to reset some internal states in order to accept new requests. Recovery is initiated by the NVRAM manager (③): one or more read attempts shall be made before continuing to read the redundant block or ROM data. If recovery actions imply a loss of redundancy or the use of ROM data, the NVRAM manager reports the loss of data quality via the job result. A DEM error is reported for the loss of redundancy (see Loss of redundancy). If the recovery also fails (④), the NVRAM manager reports NVM_E_REQ_FAILED error to the DEM and sets the job result to NOK (⑤), see [NVM API request failure](#).

6.2.3.2 Roles of the modules

6.2.3.2.1 Flash controller

Detection	HW dependent.
Reaction	N/A
Report	Depending on the Driver configuration or HW implementation, the error can be reported in a register or the controller can report the error to the driver with an interrupt.
Recovery	See NVRAM Manager.

6.2.3.2.2 Flash driver

Detection	Reported by the Flash controller (see Flash controller above).
Reaction	<ul style="list-style-type: none"> • [SWS_Fls_00106] The job is aborted. • [FLS052] The module state is set to MEMIF_IDLE, ready to accept new jobs.
Report	<ul style="list-style-type: none"> • [SWS_Fls_00004] [SWS_Fls_00106] The error is reported to the DEM with the error code FLS_E_READ_FAILED Depending on the Flash Driver configuration: <ul style="list-style-type: none"> • [SWS_Fls_00106] [SWS_Fls_00035] The error shall be polled by the Flash EEPROM Emulation with the function Fls_GetJobResult (job result set to MEMIF_JOB_FAILED). • [SWS_Fls_00263] [FLS168] The error shall be reported to the Flash EEPROM Emulation by the callback function Fee_JobErrorNotification.
Recovery	See NVRAM Manager.

6.2.3.2.3 Flash Eeprom emulation

Detection	Reported by the Flash Driver (see Flash driver above).
Reaction	[SWS_Fee_00054] Implementation specific error handling.
Report	Depending on the configuration: <ul style="list-style-type: none"> • [SWS_Fee_00091] [SWS_Fee_00035] The error shall be polled by the Memory Abstraction Interface with the function Fee_GetJobResult (job result set to MEMIF_JOB_FAILED). • [SWS_Fee_00056] [SWS_Fee_00054] The error shall be reported to the NVRAM Manager via the Callback function NvM_JobErrorNotification.
Recovery	See NVRAM Manager.

6.2.3.2.4 Memory Abstraction Interface

Detection	Reported by the Flash Eeprom Emulation (see Flash Eeprom emulation above), only if the stack is configured in polling mode
Reaction	N/A

Report	Depending on the configuration: <ul style="list-style-type: none"> • [MemIf043] [MemIf053] The error shall be polled by the NVRAM manager with the function MemIf_GetJobResult (job result set to MEMIF_JOB_FAILED).
Recovery	See NVRAM Manager.

6.2.3.2.5 NVRAM Manager

Detection	Depending on the stack configuration: <ul style="list-style-type: none"> • Polling of the job result MEMIF_JOB_FAILED by the function MemIf_GetJobResult (see Memory Abstraction Interface above). • Notification by FEE with the callback function NvM_JobErrorNotification (see Flash Eeprom emulation above).
Reaction	N/A
Report	<ul style="list-style-type: none"> • [SWS_NvM_00470] [SWS_NvM_00546] If a loss of redundancy is detected, the job result is set to NVM_REQ_REDUNDANCY_FAILED and NVM_E_LOSS_OF_REDUNDANCY error is reported to the DEM. • [SWS_NvM_00470] If there is use of ROM data during recovery the job result is set to NVM_REQ_RESTORED_FROM_ROM. • [SWS_NvM_00279] [SWS_NvM_00288] If the recovery mechanisms “read retry” “read redundant block” and “read ROM block” fail, the error NVM_E_REQ_FAILED is reported to the DEM. Depending on the configuration : <ul style="list-style-type: none"> • [SWS_NvM_00451] [SWS_NvM_00359] [SWS_NvM_00213] The error shall be polled by the user with the function NvM_GetErrorStatus (job result set to NVM_REQ_NOT_OK). • [SWS_NvM_00113] [SWS_NvM_00260] The error shall be reported to the user via the configurable callbacks SingleBlockCallbackFunction or MultiBlockCallbackFunction.
Recovery	<ul style="list-style-type: none"> • [SWS_NvM_00390] [SWS_NvM_00171] [SWS_NvM_00172] [SWS_NvM_00391] [SWS_NvM_00388] The NVRAM Manager controls the error recovery mechanism. The recovery mechanisms consist of (if configured) “read retry”, “read redundant block” and “read ROM block”.

6.2.3.2.6 Application Software Component

Detection	If necessary for the design of an error handling strategy, the SWC can be designed in two different ways: <ul style="list-style-type: none"> • it polls the job status with the GetErrorStatus operation on the client port connected to the NVM • it provides a server runnables attached to a NvMNotifyJobFinished server port which shall be invoked by the NVM. See sections <ul style="list-style-type: none"> • 13.3.1.3 Port Interface • 13.3.2 Ports and Port Interface for Notifications
------------------	---

6.2.4 Flash compare job error

6.2.4.1 Summary

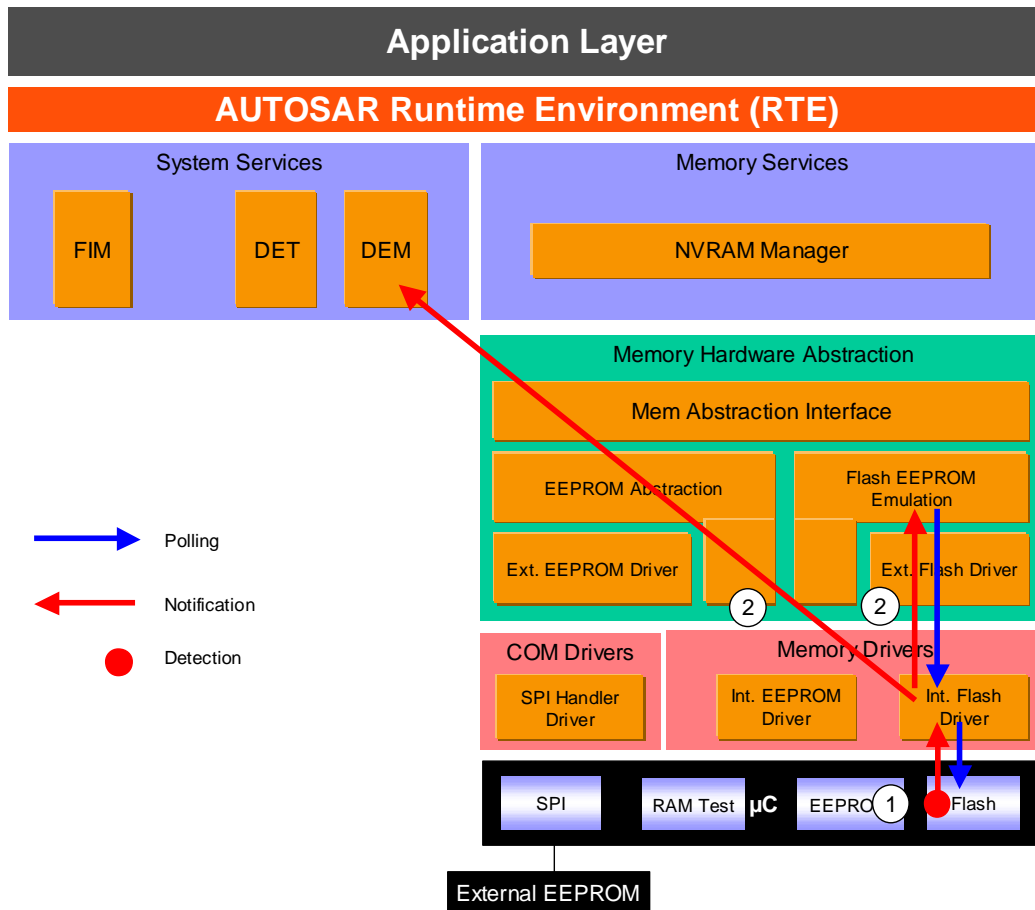

Figure 18: Information path for the flash compare job error (internal flash)

Note: Flash compare function is an internal mechanism for the Flash EEPROM Emulation to determine whether erasing / writing is needed or not.

Compare job error is detected by HW (①). Flash Driver is the first SW module involved, and is responsible for the report to the DEM and to the Flash EEPROM Emulation (②) which have to reset some internal states in order to accept new requests.

6.2.4.2 Roles of the modules

6.2.4.2.1 Flash controller

Detection	HW dependent
Reaction	N/A
Report	Depending on the Driver configuration or HW implementation, the error can be reported in a register or the controller can report the error to the driver with an interrupt.
Recovery	N/A

6.2.4.2.2 Flash driver

Detection	Reported by the Flash controller (see Flash controller above).
Reaction	<ul style="list-style-type: none"> • [SWS_Fls_00154] The job is aborted. • [FLS052] The module state is set to MEMIF_IDLE, ready to accept new jobs.
Report	<ul style="list-style-type: none"> • [SWS_Fls_00004] [SWS_Fls_00154] The error is reported to the DEM with the error code FLS_E_COMPARE_FAILED. Depending on the Flash Driver configuration: <ul style="list-style-type: none"> • [SWS_Fls_00154] [SWS_Fls_00035] The error shall be polled by the Flash EEPROM Emulation with the function Fls_GetJobResult (job result set to MEMIF_JOB_FAILED). • [SWS_Fls_00263] [FLS168] The error shall be reported to the Flash EEPROM Emulation by the callback function Fee_JobErrorNotification.
Recovery	N/A

6.2.4.2.3 Flash Eeprom emulation

Detection	Reported by the Flash Driver (see Flash driver above).
Reaction	[SWS_Fee_00054] Implementation specific error handling.
Report	N/A
Recovery	N/A

6.2.5 External Flash Hardware ID Mismatch

6.2.5.1 Summary

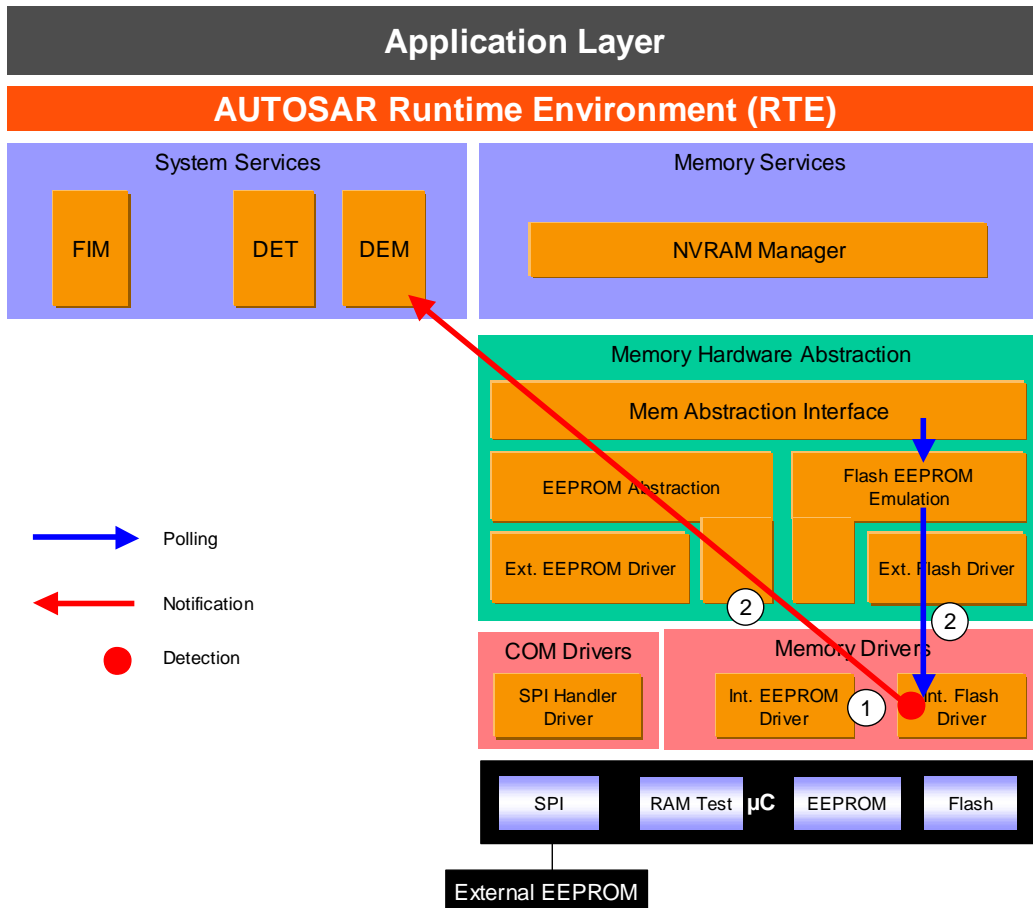

Figure 19: Information path for the External Flash Hardware ID Mismatch

During the initialization of the external flash driver, the FLS module checks if there is a mismatch between the hardware ID of the external flash device and the corresponding published parameter (①). If there is a mismatch, the module stays uninitialized. An error is reported to the DEM and error status can also be forwarded to upper layers via polling (②). No further reaction is described (error not taken into account at the NVRAM manager level). There is no recovery action.

6.2.5.2 Roles of the modules

6.2.5.2.1 External Flash driver

Detection	[SWS_Fls_00144] During the initialization of the external flash driver, the FLS module shall check if there is a mismatch between the hardware ID of the external flash device and the corresponding published parameter.
Reaction	• [FLS] Sets the FLS module status to FLS_E_UNINIT.

	<ul style="list-style-type: none"> • [SWS_Fls_00144] The FLS module shall not initialize itself.
Report	<ul style="list-style-type: none"> • [SWS_Fls_00144] [SWS_Fls_00004] The error is reported to the DEM with the error code FLS_E_UNEXPECTED_FLASH_ID. • [SWS_Fls_00034] The error can be polled with the function Fls_GetStatus (module status set to FLS_E_UNINIT).
Recovery	N/A

6.2.5.2.2 Flash Eeprom emulation

Detection	Reported by the Flash Driver.
Reaction	N/A
Report	[SWS_Fee_00090] The error can be polled by Memory Abstraction Interface with the function Fee_GetStatus (module status set to Memif_E_UNINIT).
Recovery	N/A

6.2.5.2.3 Memory Abstraction Interface

Detection	Reported by the Flash Eeprom emulation.
Reaction	N/A
Report	N/A
Recovery	N/A

6.2.6 EEPROM write job error

6.2.6.1 Summary

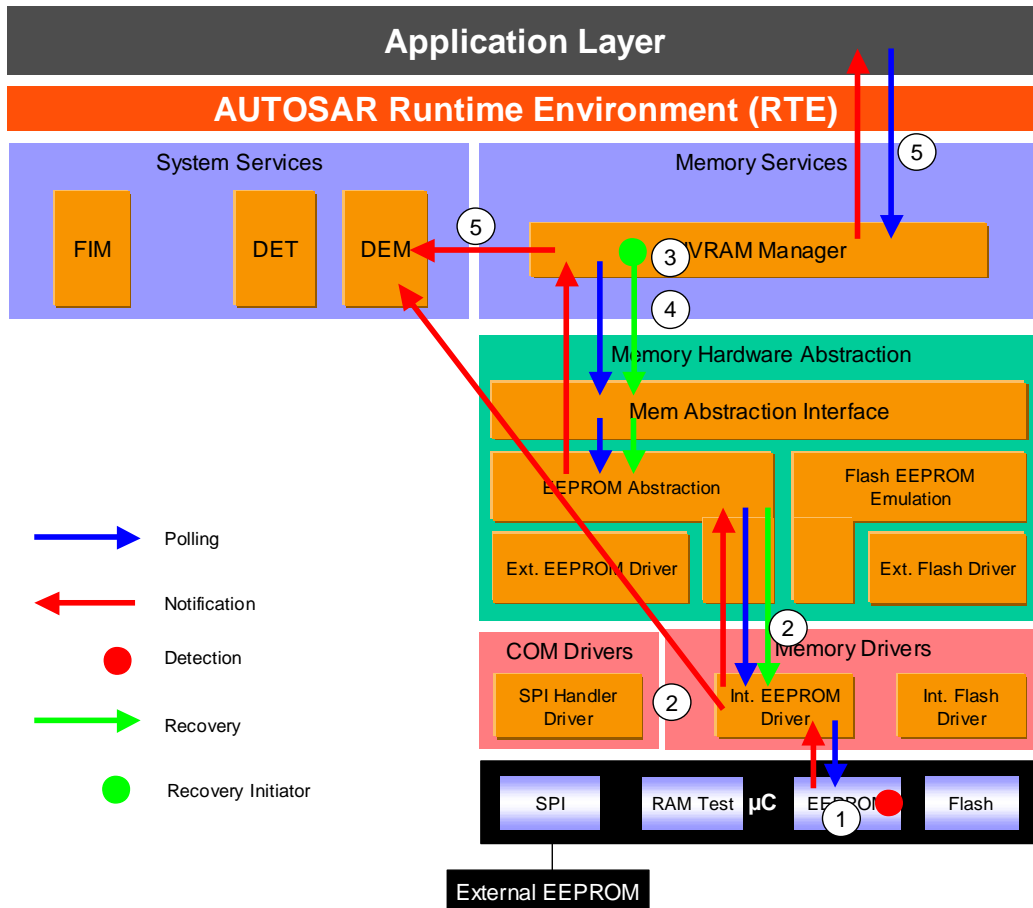

Figure 20: Information path for the EEPROM write job error (internal EEPROM)

Write job error is detected by HW (①). EEPROM Driver is the first SW module involved, and is responsible for the report to the DEM and to upper layers (②). Upper layers have to reset some internal states in order to accept new requests. A recovery mechanism is present in the NVM module which permits to retry a write job in case of failure (③). If the recovery also fails (④), the NVRAM manager reports NVM_E_REQ_FAILED error to the DEM and sets the job result to NOK (⑤), see [NVM API request failure](#).

6.2.6.2 Roles of the modules

6.2.6.2.1 EEPROM controller

Detection	HW dependent
Reaction	N/A
Report	Depending on the Driver configuration or HW implementation, the error

	can be reported in a register or the controller can report the error to the driver with an interrupt.
Recovery	See NVRAM Manager.

6.2.6.2.2 EEPROM driver

Detection	Reported by the EEPROM controller (see EEPROM controller above).
Reaction	<ul style="list-style-type: none"> • [SWS_Eep_00068] The job is aborted. • [SWS_Eep_00068] The module state is set to MEMIF_IDLE, ready to accept new jobs.
Report	<ul style="list-style-type: none"> • The error is reported to the DEM with the error code EEP_E_WRITE_FAILED. Depending on the EEPROM Driver configuration: <ul style="list-style-type: none"> • [SWS_Eep_00068] The error shall be polled by the EEPROM Abstraction with the function Eep_GetJobResult (job result set to MEMIF_JOB_FAILED). • [SWS_Eep_00068] The error shall be reported to the EEPROM Abstraction by the callback function Fee_JobErrorNotification.
Recovery	See NVRAM Manager.

6.2.6.2.3 EEPROM Abstraction

Detection	Reported by the Eeprom Driver (see EEPROM driver above).
Reaction	[SWS_Ea_00053] [SWS_Ea_00055] Implementation specific error handling.
Report	Depending on the configuration: <ul style="list-style-type: none"> • [SWS_Ea_00035] The error shall be polled by the Memory Abstraction Interface with the function Eep_GetJobResult (job result set to MEMIF_JOB_FAILED). • [SWS_Ea_00053] [SWS_Ea_00095] The error shall be reported to the NVRAM Manager via the Callback function NvM_JobErrorNotification.
Recovery	See NVRAM Manager.

6.2.6.2.4 Memory Abstraction Interface

Detection	Reported by the Eeprom Abstraction (see EEPROM Abstraction above), only if the stack is configured in polling mode
Reaction	N/A
Report	Only if the stack is configured in polling mode : <ul style="list-style-type: none"> • [MemIf043] [MemIf053] The error shall be polled by the NVRAM manager with the function MemIf_GetJobResult (job result set to MEMIF_JOB_FAILED).
Recovery	See NVRAM Manager.

6.2.6.2.5 NVRAM Manager

Detection	<p>Depending on the stack configuration:</p> <ul style="list-style-type: none"> • Polling of the job result MEMIF_JOB_FAILED by the function MemIf_GetJobResult (see Memory Abstraction Interface above). • Notification by EA with the callback function NvM_JobErrorNotification (see EEPROM Abstraction above).
Reaction	<ul style="list-style-type: none"> • [SWS_NvM_00213] [SWS_NvM_00296] Increment write retry counter. If the number of retries is exceeded, the request is aborted.
Report	<ul style="list-style-type: none"> • [SWS_NvM_00213] [SWS_NvM_00296] If the error is confirmed, the error NVM_E_REQ_FAILED is reported to the DEM. <p>Depending on the configuration</p> <ul style="list-style-type: none"> • [SWS_NvM_00451] [SWS_NvM_00213] [SWS_NvM_00296] The error shall be polled by the user with the function NvM_GetErrorStatus (job result set to NVM_REQ_NOT_OK). • [SWS_NvM_00113] [SWS_NvM_00260] The error shall be reported to the user via the configurable callbacks SingleBlockCallbackFunction or MultiBlockCallbackFunction.
Recovery	<p>[SWS_NvM_00168] [SWS_NvM_00213] [SWS_NvM_00296] The NVRAM Manager controls the error recovery mechanism. The recovery mechanism is (if configured) “write retry”.</p>

6.2.6.2.6 Application Software Component

Detection	<p>If necessary for the design of an error handling strategy, the SWC can be designed in two different ways:</p> <ul style="list-style-type: none"> • it polls the job status with the GetErrorStatus operation on the client port connected to the NVM • it provides a server runnables attached to a NvMNotifyJobFinished server port which shall be invoked by the NVM. <p>See sections</p> <ul style="list-style-type: none"> • 13.3.1.3 Port Interface • 13.3.2 Ports and Port Interface for Notifications of Autosar_SWS_NVRAMManager.pdf
------------------	---

6.2.7 EEPROM erase job error

6.2.7.1 Summary

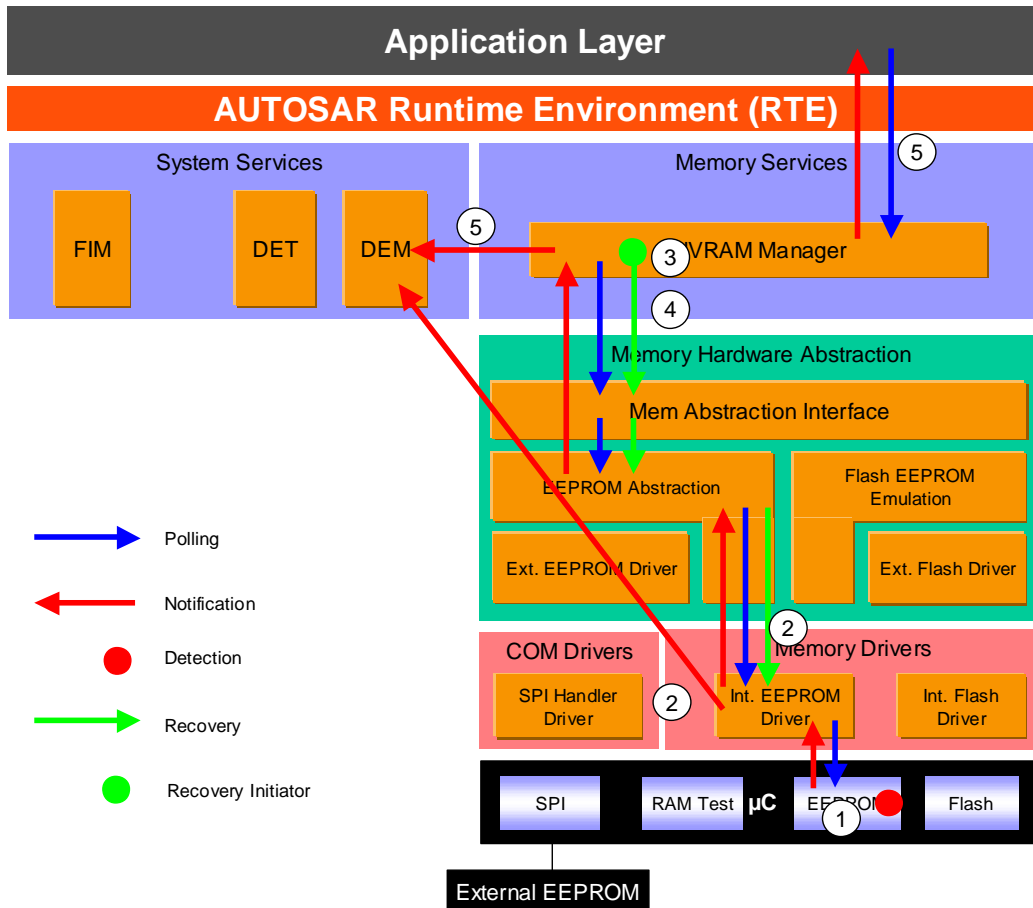

Figure 21: Information path for the EEPROM erase job error (for internal EEPROM)

Erase job error is detected by HW (①). EEPROM Driver is the first SW module involved, and is responsible for the report to the DEM and to upper layers (②). Upper layers have to reset some internal states in order to accept new requests. If the erase driver job is part of a write operation, write retries are initiated by the NVRAM manager (③) as soon as the error is reported to this layer. If the recovery also fails (④), the NVRAM manager reports NVM_E_REQ_FAILED error to the DEM and sets the job result to NOK (⑤), see [NVM API request failure](#).

6.2.7.2 Roles of the modules

6.2.7.2.1 EEPROM controller

Detection	HW dependent.
Reaction	N/A
Report	Depending on the Driver configuration or HW implementation, the

	error can be reported in a register or the controller can report the error to the driver with an interrupt.
Recovery	See NVRAM Manager.

6.2.7.2.2 EEPROM driver

Detection	Reported by the EEPROM controller (see EEPROM controller above).
Reaction	<ul style="list-style-type: none"> • [SWS_Eep_00068] The job is aborted. • [SWS_Eep_00068] The module state is set to MEMIF_IDLE, ready to accept new jobs.
Report	<ul style="list-style-type: none"> • The error is reported to the DEM with the error code EEP_E_ERASE_FAILED. Depending on the EEPROM Driver configuration: <ul style="list-style-type: none"> • [SWS_Eep_00068] The error shall be polled by the EEPROM Abstraction with the function Eep_GetJobResult (job result set to MEMIF_JOB_FAILED). • [SWS_Eep_00068] The error shall be reported to the EEPROM Abstraction by the callback function Fee_JobErrorNotification.
Recovery	See NVRAM Manager.

6.2.7.2.3 EEPROM Abstraction

Detection	Reported by the Eeprom Driver (see EEPROM driver above).
Reaction	[SWS_Ea_00053] [SWS_Ea_00055] Implementation specific error handling.
Report	Depending on the configuration: <ul style="list-style-type: none"> • [SWS_Ea_00035] The error shall be polled by the Memory Abstraction Interface with the function Eep_GetJobResult (job result set to MEMIF_JOB_FAILED). • [SWS_Ea_00053] [SWS_Ea_00095] The error shall be reported to the NVRAM Manager via the Callback function NvM_JobErrorNotification.
Recovery	See NVRAM Manager.

6.2.7.2.4 Memory Abstraction Interface

Detection	Reported by the Eeprom Abstraction (see EEPROM Abstraction above), only if the stack is configured in polling mode
Reaction	N/A
Report	Depending on the configuration: <ul style="list-style-type: none"> • [MemIf043] [MemIf053] The error shall be polled by the NVRAM manager with the function MemIf_GetJobResult (job result set to MEMIF_JOB_FAILED).
Recovery	See NVRAM Manager.

6.2.7.2.5 NVRAM Manager

Detection	Depending on the stack configuration: <ul style="list-style-type: none"> • Polling of the job result MEMIF_JOB_FAILED by the function MemIf_GetJobResult (see Memory Abstraction Interface above). • Notification by EA with the callback function NvM_JobErrorNotification (see EEPROM Abstraction above).
Reaction	If write processing involved : [SWS_NvM_00213] [SWS_NvM_00296] Increment write retry counter. If the number of retries is exceeded, the request is aborted.
Report	<ul style="list-style-type: none"> • [SWS_NvM_00271] [SWS_NvM_00269] The error NVM_E_REQ_FAILED is reported to the DEM. • The error can be reported by polling to the Memory Abstraction Interface with the function NvM_GetErrorStatus (job result set to NVM_REQ_NOT_OK).
Recovery	If write processing involved : [SWS_NvM_00168] [SWS_NvM_00213] [SWS_NvM_00296] The NVRAM Manager controls the error recovery mechanism. The recovery mechanism is (if configured) “write retry”.

6.2.7.2.6 Application Software Component

Detection	<p>If necessary for the design of an error handling strategy, the SWC can be designed in two different ways:</p> <ul style="list-style-type: none"> • it polls the job status with the GetErrorStatus operation on the client port connected to the NVM • it provides a server runnables attached to a NvMNotifyJobFinished server port which shall be invoked by the NVM. <p>See sections</p> <ul style="list-style-type: none"> • 13.3.1.3 Port Interface • 13.3.2 Ports and Port Interface for Notifications of Autosar_SWS_NVRAMManager.pdf
------------------	---

6.2.8 EEPROM read job error

6.2.8.1 Summary

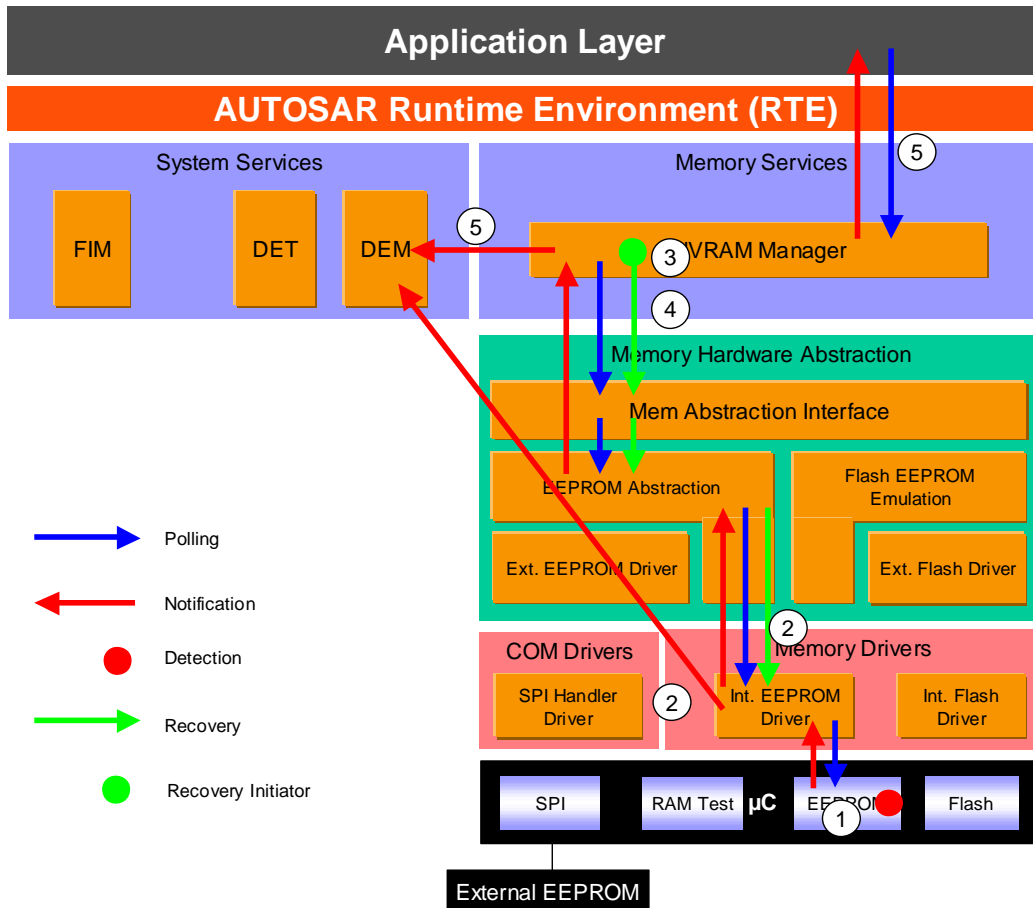

Figure 22: Information path for the EEPROM read job error (for internal EEPROM)

Read job error is detected by HW. EEPROM Driver is the first SW module involved, and is responsible for the report to the DEM and to upper layers (②). Upper layers have to reset some internal states in order to accept new requests. Recovery is initiated by the NVRAM manager (③): one or more read attempts shall be made before continuing to read the redundant block or ROM data. If recovery actions imply a loss of redundancy or the use of ROM data, the NVRAM manager reports the loss of data quality via the job result. A DEM error is reported for the loss of redundancy (see Loss of redundancy). If the recovery also fails (④), the NVRAM manager reports NVM_E_REQ_FAILED error to the DEM and sets the job result to NOK (⑤), see [NVM API request failure](#).

6.2.8.2 Roles of the modules

6.2.8.2.1 EEPROM controller

Detection	HW dependent.
Reaction	N/A
Report	Depending on the Driver configuration or HW implementation, the error can be reported in a register or the controller can report the error to the driver with an interrupt.
Recovery	See NVRAM Manager.

6.2.8.2.2 EEPROM driver

Detection	Reported by the EEPROM controller (see EEPROM controller above).
Reaction	<ul style="list-style-type: none"> • [SWS_Eep_00068] The job is aborted. • [SWS_Eep_00068] The module state is set to MEMIF_IDLE, ready to accept new jobs.
Report	<ul style="list-style-type: none"> • The error is reported to the DEM with the error code EEP_E_READ_FAILED. Depending on the EEPROM Driver configuration: <ul style="list-style-type: none"> • [SWS_Eep_00068] The error shall be polled by the EEPROM Abstraction with the function Eep_GetJobResult (job result set to MEMIF_JOB_FAILED). • [SWS_Eep_00068] The error shall be reported to the EEPROM Abstraction by the callback function Fee_JobErrorNotification.
Recovery	See NVRAM Manager.

6.2.8.2.3 EEPROM Abstraction

Detection	Reported by the Eeprom Driver (see EEPROM driver above).
Reaction	[SWS_Ea_00053] [SWS_Ea_00055] Implementation specific error handling.
Report	Depending on the configuration: <ul style="list-style-type: none"> • [SWS_Ea_00035] The error shall be polled by the Memory Abstraction Interface with the function Eep_GetJobResult (job result set to MEMIF_JOB_FAILED). • [SWS_Ea_00053] [SWS_Ea_00095] The error shall be reported to the NVRAM Manager via the Callback function NvM_JobErrorNotification.
Recovery	See NVRAM Manager.

6.2.8.2.4 Memory Abstraction Interface

Detection	Reported by the Eeprom Abstraction (see EEPROM Abstraction above), only if the stack is configured in polling mode
Reaction	N/A

Report	Depending on the configuration: <ul style="list-style-type: none"> • [MemIf043] [MemIf053] The error shall be polled by the NVRAM manager with the function MemIf_GetJobResult (job result set to MEMIF_JOB_FAILED).
Recovery	See NVRAM Manager.

6.2.8.2.5 NVRAM Manager

Detection	Reported by the Memory Abstraction Interface.
Reaction	N/A
Report	<ul style="list-style-type: none"> • [SWS_NvM_00470] [SWS_NvM_00546] If a loss of redundancy is detected, the job result is set to NVM_REQ_REDUNDANCY_FAILED and NVM_E_LOSS_OF_REDUNDANCY error is reported to the DEM. • [SWS_NvM_00470] If there is use of ROM data during recovery the job result is set to NVM_REQ_RESTORED_FROM_ROM. • [SWS_NvM_00279] [SWS_NvM_00288] If the recovery mechanisms “read retry” and “read redundant block” and “read ROM block” fail, the error NVM_E_REQ_FAILED is reported to the DEM. Depending on the configuration : <ul style="list-style-type: none"> • [SWS_NvM_00451] [SWS_NvM_00359] [SWS_NvM_00213] The error shall be polled by the user with the function NvM_GetErrorStatus (job result set to NVM_REQ_NOT_OK). • [SWS_NvM_00113] [SWS_NvM_00260] The error shall be reported to the user via the configurable callbacks SingleBlockCallbackFunction or MultiBlockCallbackFunction.
Recovery	<ul style="list-style-type: none"> • [SWS_NvM_00390] [SWS_NvM_00171] [SWS_NvM_00172] [SWS_NvM_00391] [SWS_NvM_00388] The NVRAM Manager controls the error recovery mechanism. The recovery mechanisms consist of (if configured) “read retry” ; “read redundant block” and “read ROM block”.

6.2.8.2.6 Application Software Component

Detection	If necessary for the design of an error handling strategy, the SWC can be designed in two different ways: <ul style="list-style-type: none"> • it polls the job status with the GetErrorStatus operation on the client port connected to the NVM • it provides a server runnables attached to a NvMNotifyJobFinished server port which shall be invoked by the NVM. See sections <ul style="list-style-type: none"> • 13.3.1.3 Port Interface • 13.3.2 Ports and Port Interface for Notifications of Autosar_SWS_NVRAMManager.pdf
------------------	---

6.2.9 EEPROM compare job error

6.2.9.1 Summary

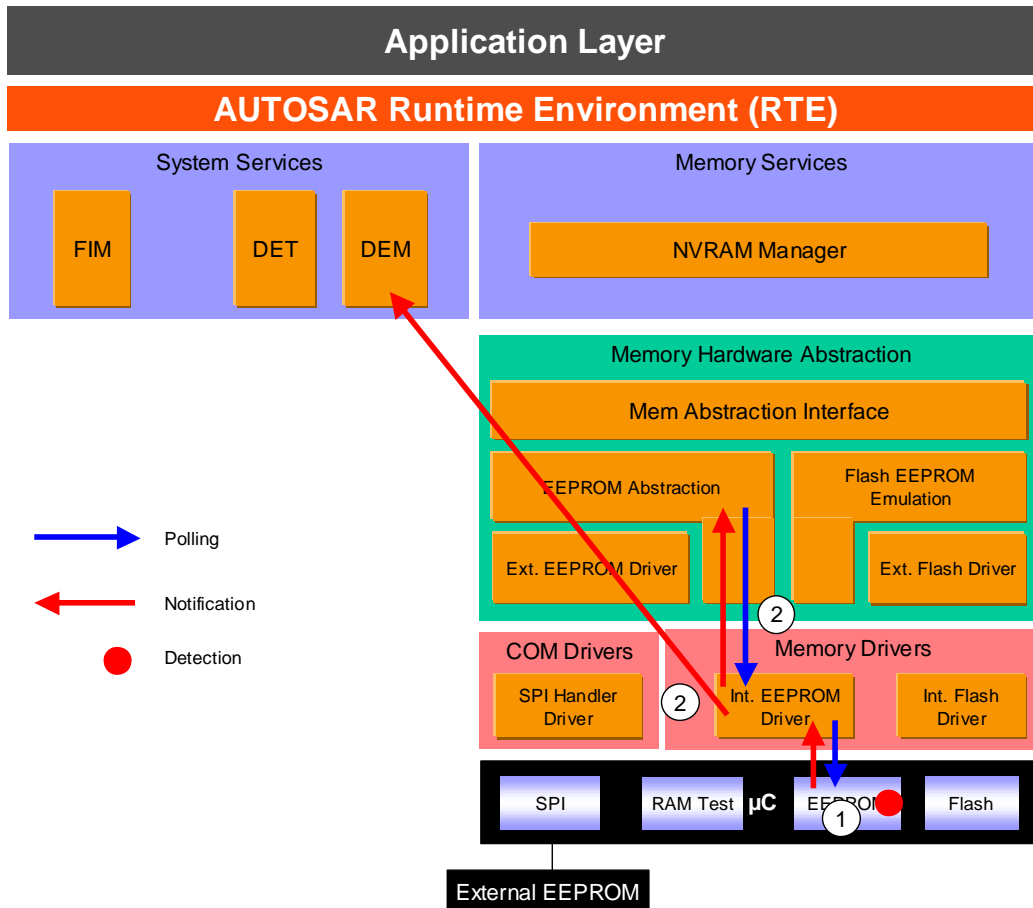

Figure 23: Information path for the EEPROM compare job error (for internal EEPROM)

Note: EEPROM compare function is an internal mechanism for the EEPROM Abstraction to determine whether erasing / writing is needed or not.

Compare job error is detected by HW (①). EEPROM Driver is the first SW module involved, and is responsible for the report to the DEM and to the Flash EEPROM Emulation (②) which have to reset some internal states in order to accept new requests.

6.2.9.2 Roles of the modules

6.2.9.2.1 EEPROM controller

Detection	HW dependent
Reaction	N/A
Report	Depending on the Driver configuration or HW implementation, the error can be reported in a register or the controller can report the error to the driver with an interrupt.

Recovery	N/A
-----------------	-----

6.2.9.2.2 EEPROM driver

Detection	Reported by the EEPROM controller (see EEPROM controller above).
Reaction	<ul style="list-style-type: none"> • [SWS_Eep_00068] The job is aborted. • [SWS_Eep_00068] The module state is set to MEMIF_IDLE, ready to accept new jobs.
Report	<ul style="list-style-type: none"> • The error is reported to the DEM with the error code EEP_E_COMPARE_FAILED. <p>Depending on the EEPROM Driver configuration:</p> <ul style="list-style-type: none"> • [SWS_Eep_00068] The error shall be polled by the EEPROM Abstraction with the function Eep_GetJobResult (job result set to MEMIF_JOB_FAILED). • [SWS_Eep_00068] The error shall be reported to the EEPROM Abstraction by the callback function Fee_JobErrorNotification.
Recovery	N/A

6.2.9.2.3 EEPROM Abstraction

Detection	Reported by the Eeprom Driver (see EEPROM driver above).
Reaction	[SWS_Ea_00053] [SWS_Ea_00055] Implementation specific error handling.
Report	<p>Depending on the configuration:</p> <ul style="list-style-type: none"> • [SWS_Ea_00035] The error shall be polled by the Memory Abstraction Interface with the function Eep_GetJobResult (job result set to MEMIF_JOB_FAILED). • [SWS_Ea_00053] [SWS_Ea_00095] The error shall be reported to the NVRAM Manager via the Callback function NvM_JobErrorNotification.
Recovery	N/A

6.3 EEPROM Abstraction / Flash Emulation level errors

6.3.1 FEE consistency check error

6.3.1.1 Summary

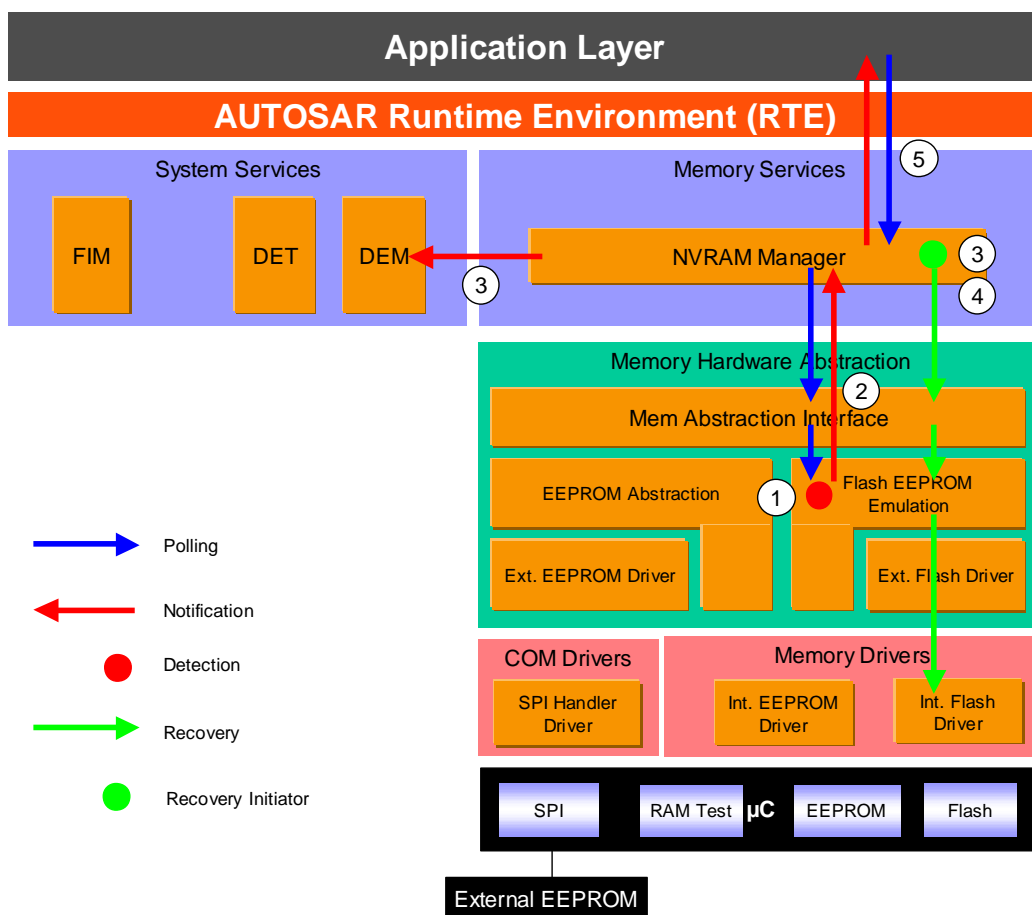

Figure 24: Information path for the Fee consistency check

The Flash EEPROM Emulation checks the consistency of the read data (①). If a consistency error is detected, error status is forwarded to the NVRAM manager (②). The NVRAM manager reports NVM_E_INTEGRITY_FAILED to the DEM (③). Recovery is also initiated: “read retry”, “read redundant block” and “read ROM block”, if configured (③). If recovery actions imply a loss of redundancy or the use of ROM data, the NVRAM manager reports the loss of data quality via the job result. A DEM error is reported for the loss of redundancy (see Loss of redundancy). If the recovery fails (④), the job result is set to NVM_REQ_INTEGRITY_FAILED (⑤).

6.3.1.2 Roles of the modules

6.3.1.2.1 Flash Eeprom emulation

Detection	[SWS_Fee_00023] Fee module checks the consistency of the read data.
Reaction	N/A
Report	Depending on the configuration: <ul style="list-style-type: none"> • [SWS_Fee_00091] [SWS_Fee_00023] The error shall be polled by the Memory Abstraction Interface with the function Fee_GetJobResult (job result set to MEMIF_BLOCK_INCONSISTENT). • [SWS_Fee_00056] [SWS_Fee_00054] The error shall be reported to the NVRAM Manager via the Callback function
Recovery	See NVRAM Manager.

6.3.1.2.2 Memory Abstraction Interface

Detection	Reported by the Flash Eeprom emulation (see Flash Eeprom emulation above), only if the stack is configured in polling mode.
Reaction	N/A
Report	Depending on the configuration: <ul style="list-style-type: none"> • [MemIf043] [MemIf053] The error shall be polled by the NVRAM manager with the function MemIf_GetJobResult (job result set to MEMIF_JOB_FAILED).
Recovery	See NVRAM Manager.

6.3.1.2.3 NVRAM Manager

Detection	Reported by the Memory Abstraction Interface (see Memory Abstraction Interface above).
Reaction	N/A
Report	<ul style="list-style-type: none"> • [SWS_NvM_00470] [SWS_NvM_00546] If a loss of redundancy is detected, the job result is set to NVM_REQ_REDUNDANCY_FAILED and NVM_E_LOSS_OF_REDUNDANCY error is reported to the DEM. • [SWS_NvM_00470] If there is use of ROM data during recovery the job result is set to NVM_REQ_RESTORED_FROM_ROM. • [SWS_NvM_00358] [SWS_NvM_00360] If the recovery mechanisms fail, the NVM reports the error NVM_E_INTEGRITY_FAILED to the DEM. If the recovery mechanism fails, depending on the stack configuration : <ul style="list-style-type: none"> • [SWS_NvM_00451] [SWS_NvM_00358] [SWS_NvM_00360] The error shall be polled by the user with the function NvM_GetErrorStatus (job result set to NVM_REQ_INTEGRITY_FAILED). • [SWS_NvM_00113] [SWS_NvM_00260] The error shall be reported

	to the user via the configurable callbacks SingleBlockCallbackFunction or MultiBlockCallbackFunction.
Recovery	<ul style="list-style-type: none"> • [SWS_NvM_00390] [SWS_NvM_00171] [SWS_NvM_00172] [SWS_NvM_00391] [SWS_NvM_00388] The NVRAM Manager controls the error recovery mechanism. The recovery mechanisms consist of (if configured) “read redundant block” and “read ROM block”.

6.3.1.2.4 Application Software Component

Detection	<p>If necessary for the design of an error handling strategy, the SWC can be designed in two different ways:</p> <ul style="list-style-type: none"> • it polls the job status with the GetErrorStatus operation on the client port connected to the NVM • it provides a server runnables attached to a NvMNotifyJobFinished server port which shall be invoked by the NVM. <p>See sections</p> <ul style="list-style-type: none"> • 13.3.1.3 Port Interface • 13.3.2 Ports and Port Interface for Notifications of Autosar_SWS_NVRAMManager.pdf
------------------	---

6.3.2 EA consistency check error

6.3.2.1 Summary

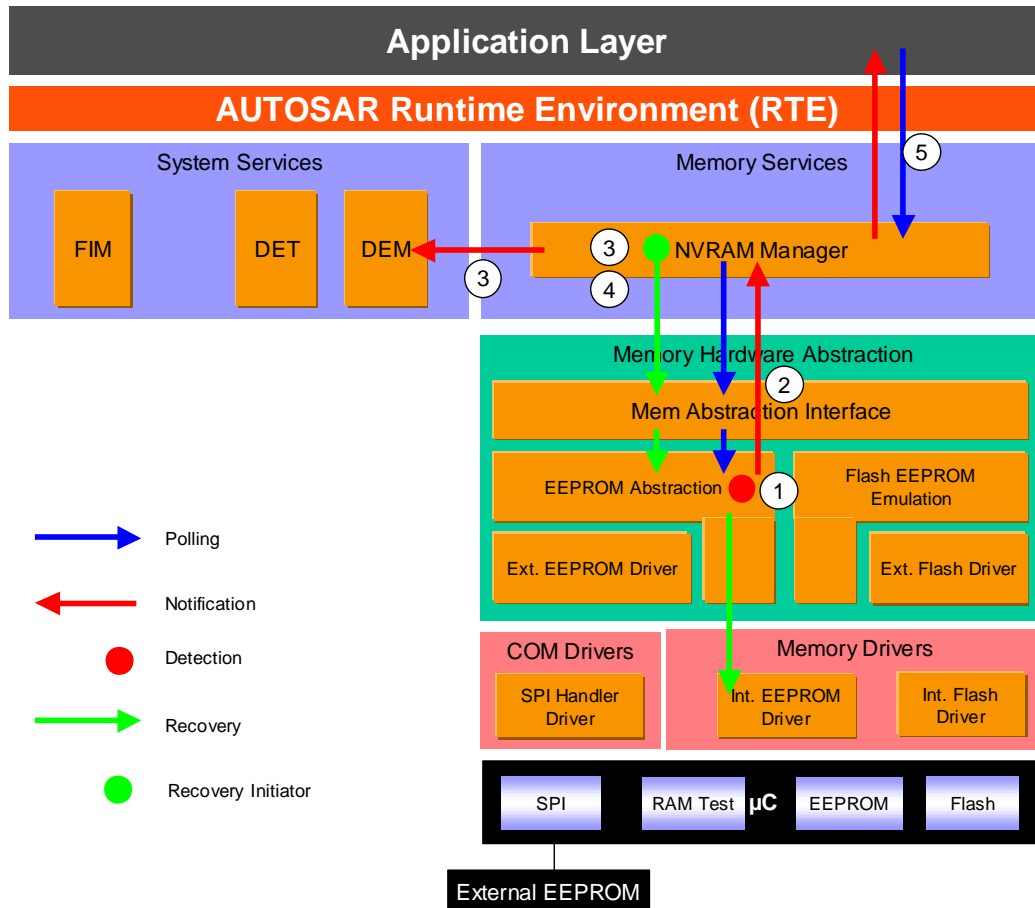

Figure 25: Information path for the EA consistency check error

The EEPROM Abstraction checks the consistency of the read data (①). If a consistency error is detected, error status is forwarded to the NVRAM manager (②). The NVRAM manager reports NVM_E_INTEGRITY_FAILED to the DEM and recovery is initiated: “read retry”, “read redundant block” and “read ROM block”, if configured (③). If recovery actions imply a loss of redundancy or the use of ROM data, the NVRAM manager reports the loss of data quality via the job result. A DEM error is reported for the loss of redundancy (see Loss of redundancy). If the recovery fails (④), the job result is set to NVM_REQ_INTEGRITY_FAILED (⑤).

6.3.2.2 Roles of the modules

6.3.2.2.1 Eeprom Abstraction

Detection	[SWS_Ea_00104] The Eeprom Abstraction module checks the consistency of the read data.
------------------	---

Reaction	N/A
Report	Depending on the configuration: <ul style="list-style-type: none"> • [SWS_Ea_00035] The error shall be polled by the Memory Abstraction Interface with the function Eep_GetJobResult (job result set to MEMIF_JOB_FAILED). • [SWS_Ea_00053] [SWS_Ea_00095] The error shall be reported to the NVRAM Manager via the Callback function NvM_JobErrorNotification.
Recovery	See NVRAM Manager.

6.3.2.2.2 Memory Abstraction Interface

Detection	Reported by the Eeprom Abstraction (see Eeprom Abstraction above), only if the stack is configured in polling mode.
Reaction	N/A
Report	Depending on the configuration: <ul style="list-style-type: none"> • [MemIf043] [MemIf053] The error shall be polled by the NVRAM manager with the function MemIf_GetJobResult (job result set to MEMIF_JOB_FAILED).
Recovery	See NVRAM Manager.

6.3.2.2.3 NVRAM Manager

Detection	Reported by the Memory Abstraction Interface.
Reaction	N/A
Report	<ul style="list-style-type: none"> • [SWS_NvM_00470] [SWS_NvM_00546] If a loss of redundancy is detected, the job result is set to NVM_REQ_REDUNDANCY_FAILED and NVM_E_LOSS_OF_REDUNDANCY error is reported to the DEM. • [SWS_NvM_00470] If there is use of ROM data during recovery the job result is set to NVM_REQ_RESTORED_FROM_ROM. • [SWS_NvM_00279] [SWS_NvM_00288] If the recovery mechanisms fail, the error NVM_E_REQ_FAILED is reported to the DEM. If the recovery mechanisms fail, depending on the configuration : <ul style="list-style-type: none"> • [SWS_NvM_00451] [SWS_NvM_00359] [SWS_NvM_00213] The error shall be polled by the user with the function NvM_GetErrorStatus (job result set to NVM_REQ_NOT_OK). • [SWS_NvM_00113] [SWS_NvM_00260] The error shall be reported to the user via the configurable callbacks SingleBlockCallbackFunction or MultiBlockCallbackFunction.
Recovery	<ul style="list-style-type: none"> • [SWS_NvM_00390] [SWS_NvM_00171] [SWS_NvM_00172] [SWS_NvM_00391] [SWS_NvM_00388] The NVRAM Manager controls the error recovery mechanism. The recovery mechanisms consist of (if configured) “read redundant block” and “read ROM block”.

6.3.2.2.4 Application Software Component

Detection	If necessary for the design of an error handling strategy, the SWC can be designed in two different ways: <ul style="list-style-type: none">• it polls the job status with the GetErrorStatus operation on the client port connected to the NVM• it provides a server runnables attached to a NvMNotifyJobFinished server port which shall be invoked by the NVM. See sections <ul style="list-style-type: none">• 13.3.1.3 Port Interface• 13.3.2 Ports and Port Interface for Notifications of Autosar_SWS_NVRAMManager.pdf
------------------	---

6.4 NVRAM manager level errors

6.4.1 NVM CRC check

6.4.1.1 Summary

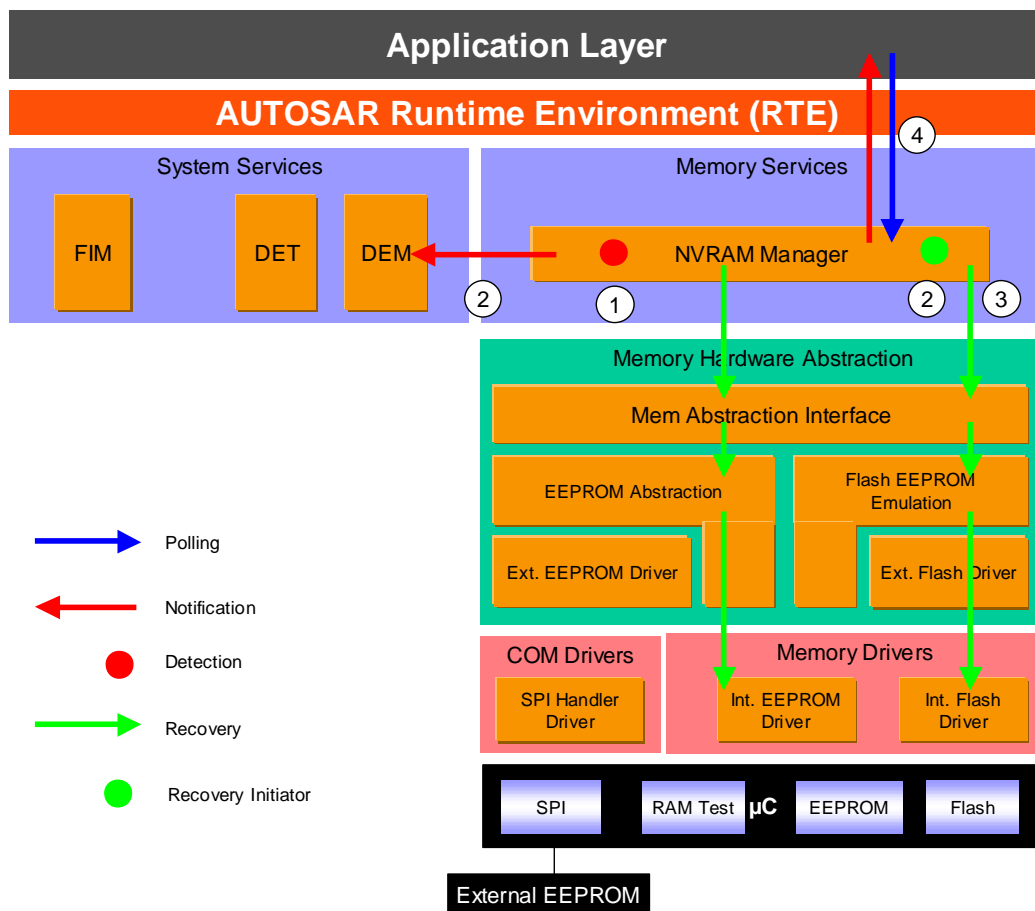

Figure 26: Information path for the NVRAM manager CRC check error

If the NV block is configured with CRC, the NVRAM Manager checks if there is a CRC mismatch on the RAM block at the end of the reading operation (①). If so, NVM_E_INTEGRITY_FAILED error is reported to the DEM. Recovery is also initiated: “read retry”, “read redundant block” and “read ROM block”, if configured (②). If recovery actions imply a loss of redundancy or the use of ROM data, the NVRAM manager reports the loss of data quality via the job result. A DEM error is reported for the loss of redundancy (see Loss of redundancy). If the recovery fails (③), the job result is set to NVM_REQ_INTEGRITY_FAILED (④).

6.4.1.2 Roles of the modules

6.4.1.2.1 NVRAM Manager

Detection	[SWS_NvM_00292] [SWS_NvM_00201] [SWS_NvM_00292] A CRC Check is requested at the end of the read operation.
Reaction	N/A
Report	<ul style="list-style-type: none"> • [SWS_NvM_00470] [SWS_NvM_00546] If a loss of redundancy is detected, the job result is set to NVM_REQ_REDUNDANCY_FAILED and NVM_E_LOSS_OF_REDUNDANCY error is reported to the DEM. • [SWS_NvM_00470] If there is use of ROM data during recovery the job result is set to NVM_REQ_RESTORED_FROM_ROM. • [SWS_NvM_00294] [SWS_NvM_00203] [SWS_NvM_00204] [SWS_NvM_00294] If a CRC mismatch occurs, the NVM reports the error NVM_E_INTEGRITY_FAILED to the DEM and the job result is set to NVM_REQ_INTEGRITY_FAILED. <p>Depending on the configuration :</p> <ul style="list-style-type: none"> • [SWS_NvM_00451] [SWS_NvM_00295] [SWS_NvM_00204] The error shall be polled by the user with the function NvM_GetErrorStatus. • [SWS_NvM_00113] [SWS_NvM_00260] The error shall be reported to the user via the configurable callbacks SingleBlockCallbackFunction or MultiBlockCallbackFunction
Recovery	[SWS_NvM_00390] [SWS_NvM_00171] [SWS_NvM_00172] [SWS_NvM_00391] [SWS_NvM_00388] [SWS_NvM_00526] [SWS_NvM_00293] The NVRAM Manager controls the error recovery mechanism. The recovery mechanisms consist of (if configured) “read retry”, “read redundant block” and “read ROM block”.

6.4.2 NVM write verification error

6.4.2.1 Summary

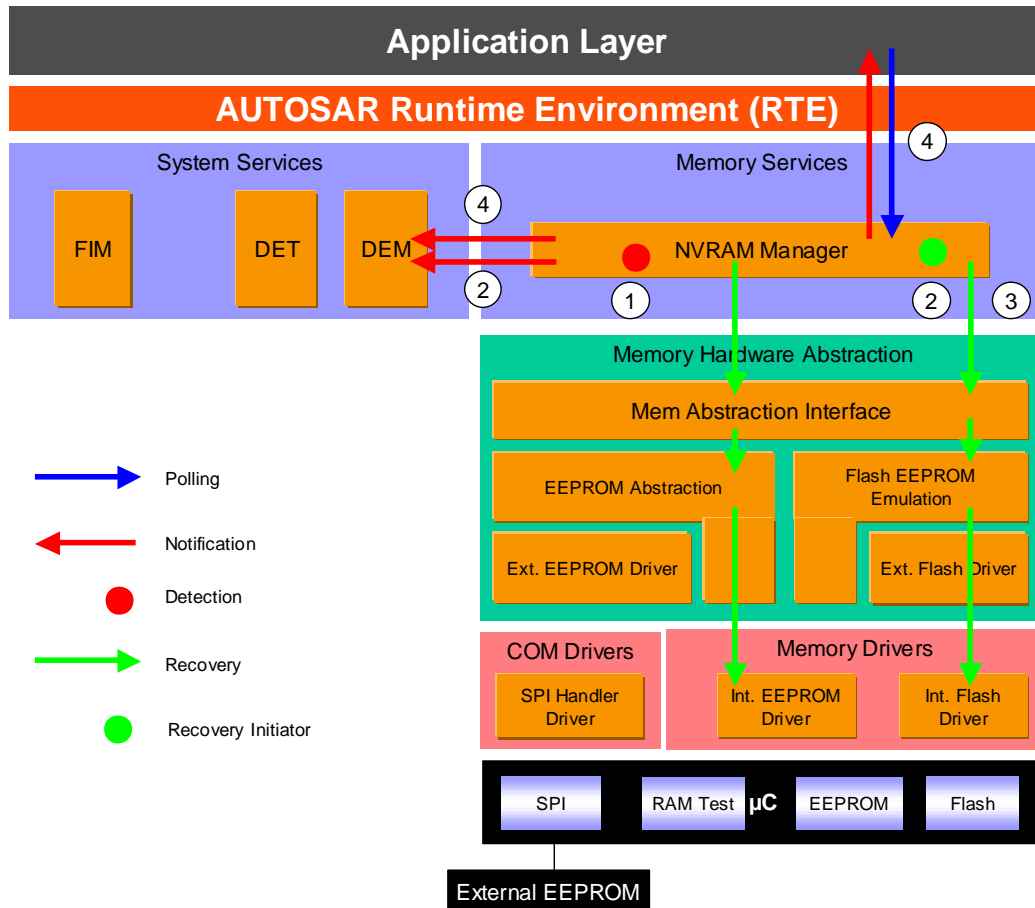

Figure 27: Information path for the write verification error

The NVRAM Block written to NV memory is immediately read back and compared with the original content in RAM (①). If the verification fails, NVM_E_VERIFY_FAILED error is reported to the DEM, and recovery is initiated with write retries if configured (②). If the recovery fails (③), the NVRAM manager reports NVM_E_REQ_FAILED error to the DEM and sets the job result to NVM_REQ_NOT_OK (④), see [NVM API request failure](#).

6.4.2.2 Roles of the modules

6.4.2.2.1 NVRAM Manager

Detection	[SWS_NvM_00528] [SWS_NvM_00530] The NVRAM Block written to NV memory is immediately read back and compared with the original content in RAM. Note: In case the read back fails then the write verification shall fail and no read retries shall be performed.
Reaction	N/A

Report	<ul style="list-style-type: none"> [SWS_NvM_00528] The error NVM_E_VERIFY_FAILED is reported to the DEM if there is a mismatch. [SWS_NvM_00213] If recovery actions fail, the job result is set to NVM_REQ_NOT_OK and the NVRAM manager reports NVM_E_REQ_FAILED to the DEM (see NVM API request failure).
Recovery	[SWS_NvM_00529] If the write verification fails then write retries are performed.

6.4.3 Static block check error

6.4.3.1 Summary

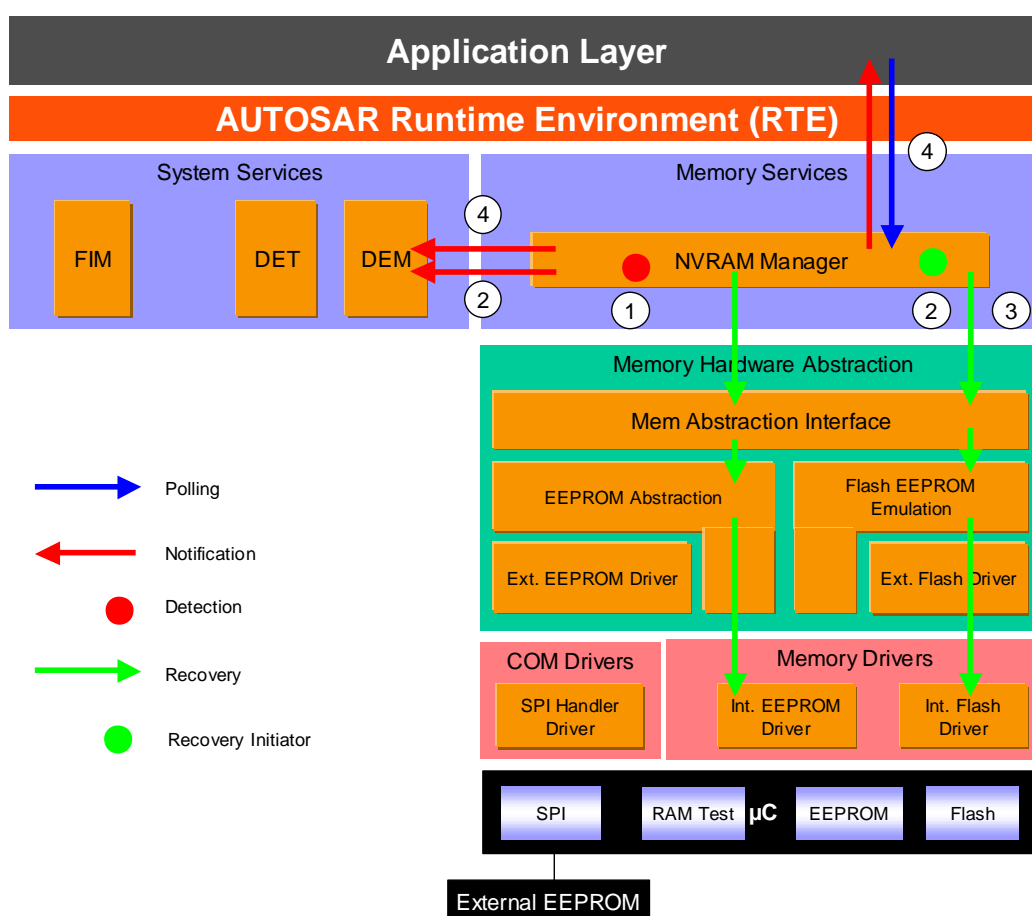

Figure 28: Information path for the Static Block check error

The Static Block ID check mechanism located in the NVRAM manager provides means to detect if the wrong block has been read from the NV memory due to an addressing problem. The NVRAM Manager stores the NV Block Header including the Static Block ID in the NV Block each time the block is written to NV memory. During read operation, the NV header is compared to the requested block ID (①).

If the static block ID check fails then the failure NVM_E_WRONG_BLOCK_ID is reported to DEM and read recovery is initiated (“read retry”, “read redundant block” and “read ROM block” if configured) (②). If recovery actions imply a loss of redundancy or the use of ROM data, the NVRAM manager reports the loss of data

quality via the job result. A DEM error is reported for the loss of redundancy (see Loss of redundancy). If the recovery also fails (③), the NVRAM manager reports NVM_E_REQ_FAILED error to the DEM and sets the job result to NVM_REQ_NOT_OK (④), see [NVM API request failure](#).

6.4.3.2 Roles of the modules

6.4.3.2.1 NVRAM Manager

Detection	[SWS_NvM_00524] The NVRAM manager checks the block ID stored in the NVRAM Block header.
Reaction	N/A
Report	<ul style="list-style-type: none"> • [SWS_NvM_00470] [SWS_NvM_00546] If a loss of redundancy is detected, the job result is set to NVM_REQ_REDUNDANCY_FAILED and NVM_E_LOSS_OF_REDUNDANCY error is reported to the DEM. • [SWS_NvM_00470] If there is use of ROM data during recovery the job result is set to NVM_REQ_RESTORED_FROM_ROM. • [SWS_NvM_00525] The error NVM_E_WRONG_BLOCK_ID is reported to the DEM. • If recovery actions fail, the job result is set to NVM_REQ_NOT_OK and the NVRAM manager reports NVM_E_REQ_FAILED to the DEM (see NVM API request failure).
Recovery	[SWS_NvM_00525] [SWS_NvM_00526] If the static block ID check fails, read recovery is initiated (“read retry”, “read redundant block” and “read ROM block”).

6.4.4 Loss of redundancy

6.4.4.1 Summary

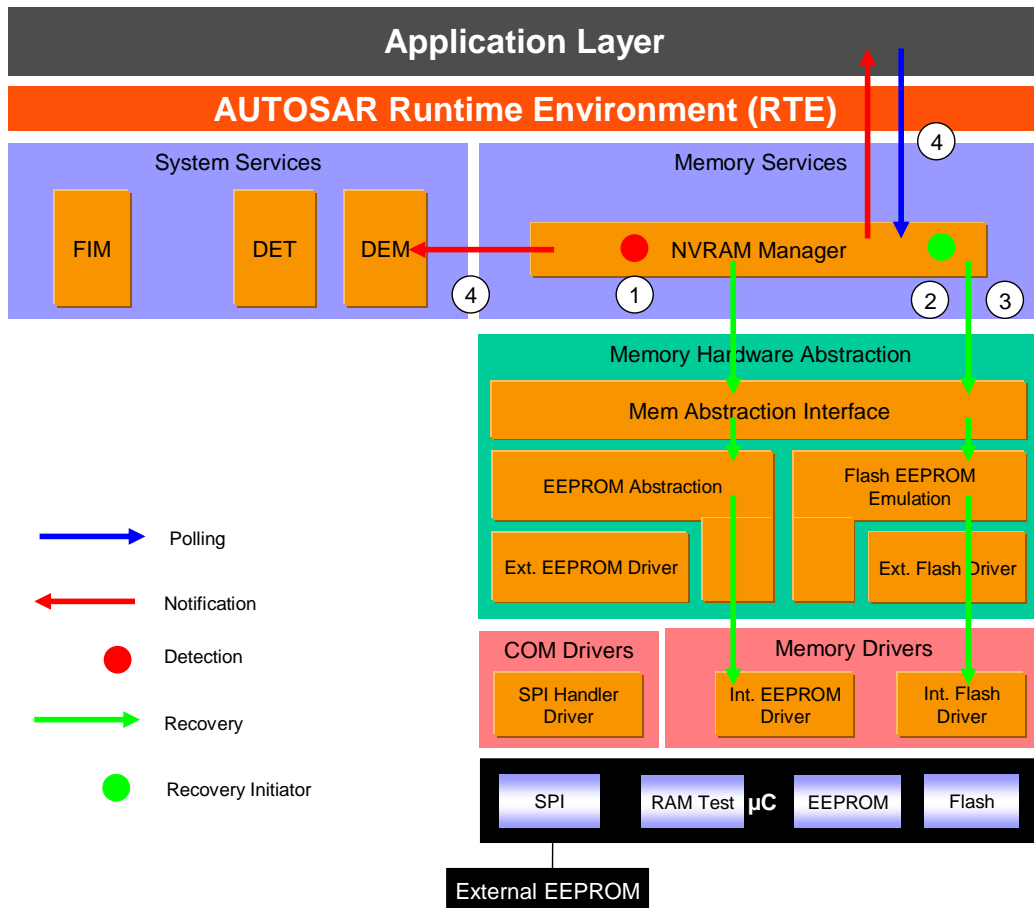

Figure 29: Information path for the loss of redundancy error

In case one redundant block is invalid during read or write (①), an attempt is made by the NVRAM manager to immediately recover the NV Block using data from the corrupt NV Block (②). If the recovery fails (③), the error code NVM_E_LOSS_OF_REDUNDANCY is reported to the DEM and the NVRAM manager sets the job result to NVM_REQ_REDUNDANCY_FAILED (④).

6.4.4.2 Roles of the modules

6.4.4.2.1 NVRAM Manager

Detection	[SWS_NvM_00531] The NVRAM manager detects a loss of redundancy during a read operation or a write operation.
Reaction	N/A
Report	[SWS_NvM_00546] In case recovery fails (see below), the error code NVM_E_LOSS_OF_REDUNDANCY is reported to the DEM. Depending on the configuration :

	<ul style="list-style-type: none"> • [SWS_NvM_00451] [SWS_NvM_00470] The error shall be polled by the user with the function NvM_GetErrorStatus (job result set to NVM_REQ_REDUNDANCY_FAILED). • [SWS_NvM_00113] [SWS_NvM_00260] The error shall be reported to the user via the configurable callbacks SingleBlockCallbackFunction or MultiBlockCallbackFunction.
Recovery	[SWS_NvM_00531] An attempt is made to immediately recover the NV Block using data from the incorrupt NV Block.

6.4.4.2.2 Application Software Component

Detection	<p>If necessary for the design of an error handling strategy, the SWC can be designed in two different ways:</p> <ul style="list-style-type: none"> • it polls the job status with the GetErrorStatus operation on the client port connected to the NVM • it provides a server runnables attached to a NvMNotifyJobFinished server port which shall be invoked by the NVM. <p>See sections</p> <ul style="list-style-type: none"> • 13.3.1.3 Port Interface • 13.3.2 Ports and Port Interface for Notifications of Autosar_SWS_NVRAMManager.pdf
------------------	---

6.4.5 NVM API request failure

6.4.5.1 Summary

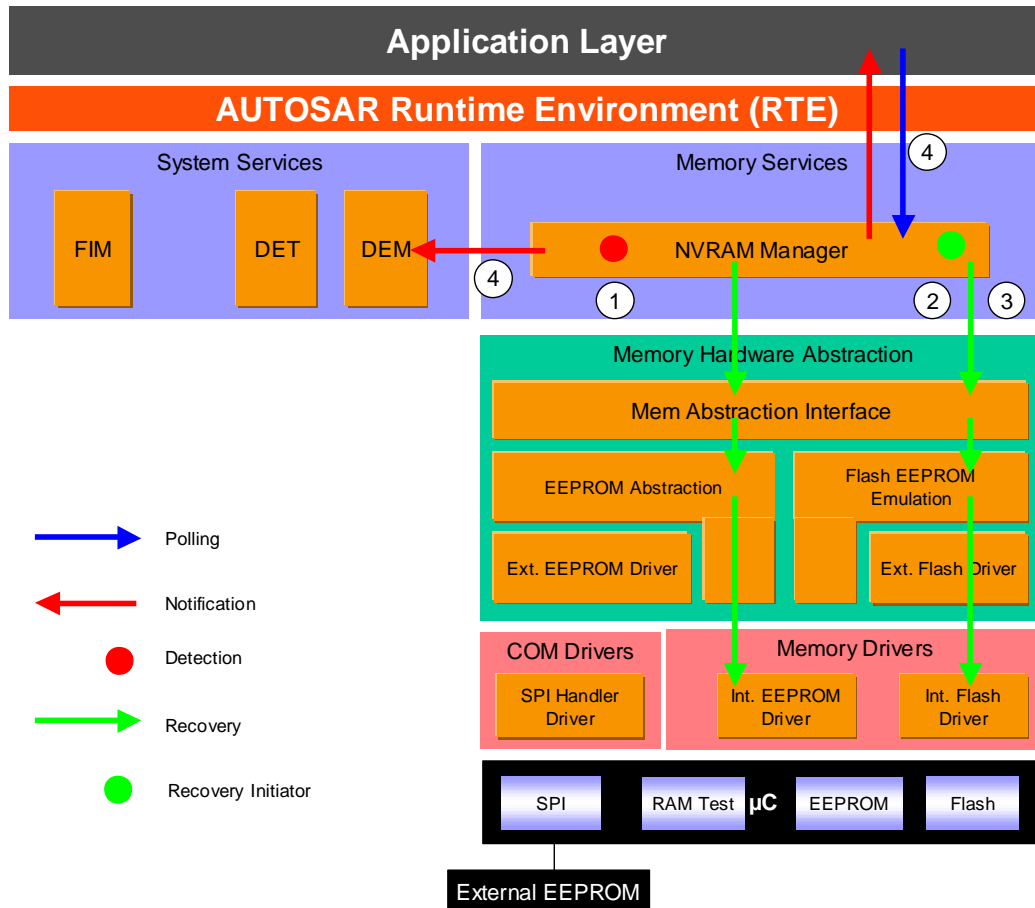

Figure 30: Information path for the NVM API request failure

The NVRAM manager is notified of an error detected by the subsequent layers during the process of a NVM function or by an internal detection mechanism, write verification static block check, or config ID mismatch (①).

Different recovery mechanisms are available at the NVRAM manager level depending on the type of function involved, writing or reading (②). If the available recovery mechanisms fail (③), the NVM manager reports NVM_E_REQ_FAILED error to the DEM and sets the job result to NVM_REQ_NOT_OK (④).

6.4.5.2 Roles of the modules

6.4.5.2.1 NVRAM Manager

Detection	[SWS_NvM_00275] [SWS_NvM_00305] [SWS_NvM_00361] [SWS_NvM_00302] [SWS_NvM_00296] [SWS_NvM_00023]
------------------	--

	[SWS_NvM_00359] [SWS_NvM_00213] [SWS_NvM_00271] The NVRAM manager is notified of an error detected by the subsequent layers during the process of a NVM function (NvM_ReadAll, NvM_InvalidateNvBlock, NvM_WriteAll, NvM_ReadBlock, NvM_WriteBlock, NvM_EraseNvBlock)
Reaction	N/A
Report	<ul style="list-style-type: none"> • [SWS_NvM_00213] [SWS_NvM_00296] [SWS_NvM_00279] [SWS_NvM_00288] If the recovery mechanisms fail (see below), the error NVM_E_REQ_FAILED is reported to the DEM. <p>Depending on the configuration :</p> <ul style="list-style-type: none"> • [SWS_NvM_00451] [SWS_NvM_00295] [SWS_NvM_00204] The error shall be polled by the user with the function NvM_GetErrorStatus (job result set to NVM_REQ_NOT_OK). • [SWS_NvM_00113] [SWS_NvM_00260] The error shall be reported to the user via the configurable callbacks SingleBlockCallbackFunction or MultiBlockCallbackFunction.
Recovery	[SWS_NvM_00168] [SWS_NvM_00213] [SWS_NvM_00296] [SWS_NvM_00390] [SWS_NvM_00171] [SWS_NvM_00172] [SWS_NvM_00391] [SWS_NvM_00388] The NVRAM Manager controls the error recovery mechanism. Recovery actions depend on the type of operations in progress: write operation, read operation or other. For read operation, the recovery mechanisms consist of (if configured) “read retry”, “read redundant block” and “read rom block”. For write operation, the recovery mechanism is (if configured) “write retry”.

6.4.5.2.2 Application Software Component

Detection	<p>If necessary for the design of an error handling strategy, the SWC can be designed in two different ways:</p> <ul style="list-style-type: none"> • it polls the job status with the GetErrorStatus operation on the client port connected to the NVM • it provides a server runnables attached to a NvMNotifyJobFinished server port which shall be invoked by the NVM. <p>See sections</p> <ul style="list-style-type: none"> • 13.3.1.3 Port Interface • 13.3.2 Ports and Port Interface for Notifications <p>of Autosar_SWS_NVRAMManager.pdf</p>
------------------	--