

<b>Document Title</b>	Specification of Port Driver
<b>Document Owner</b>	AUTOSAR
<b>Document Responsibility</b>	AUTOSAR
<b>Document Identification No</b>	040
<b>Document Classification</b>	Standard

<b>Document Version</b>	3.2.0
<b>Document Status</b>	Final
<b>Part of Release</b>	4.0
<b>Revision</b>	2

<b>Document Change History</b>			
<b>Date</b>	<b>Version</b>	<b>Changed by</b>	<b>Change Description</b>
03.11.2010	3.2.0	AUTOSAR Administration	<ul style="list-style-type: none"> <li>• Removed Port132 and updated Figure 1</li> <li>• Rephrased Port114 and Port075</li> <li>• Removed Port210</li> <li>• Added Chapter 12</li> </ul>
30.11.2009	3.1.0	AUTOSAR Administration	<ul style="list-style-type: none"> <li>• A lot of requirements are changed to make them atomic or /and more clear. No technical content changes. Look Chapter 14 for the complete list.</li> <li>• Debugging Concept Inserted.</li> <li>• Insertion of the new configuration parameter to enable or disable the mode of the port pins at run time.</li> <li>• Checking of Port_GetVersionInfo.</li> <li>• Legal disclaimer revised</li> </ul>
23.06.2008	3.0.2	AUTOSAR Administration	Legal disclaimer revised
23.01.2008	3.0.1	AUTOSAR Administration	Table formatting corrected

Document Change History			
27.11.2007	3.0.0	AUTOSAR Administration	<ul style="list-style-type: none"> <li>• Update to Chapter 10 configuration.</li> <li>• Inclusion of Port Container</li> <li>• Inclusion of new SRS general requirements</li> <li>• Removal of redundant function: Dem_ReportErrorEvent()</li> <li>• Development errors and error codes added</li> <li>• Rewording of requirements (as part of the SWS Improvements)</li> <li>• Renaming of configuration parameter (PORT_PIN_DIRECTION_CHANGES_ALLOWED -&gt; PORT_SEP_PIN_DIRECTION_API)</li> <li>• Technical Office Improvements: wording improvements, alignment of API description.</li> <li>• Document meta information extended</li> <li>• Small layout adaptations made</li> </ul>
31.01.2007	2.1.0	AUTOSAR Administration	<ul style="list-style-type: none"> <li>• New API introduced: Port_SetPinMode()</li> <li>• New Module type definition: Port_PinModeType</li> <li>• Updated to section 5.1.2: Inclusion of new file structure information</li> <li>• Inclusion of new pre-processor switch PortSetPinModeApi</li> <li>• New configurable parameter introduced: PortPinInitialMode</li> <li>• Rewording of requirement PORT105.</li> <li>• Removal of redundant requirements PORT119 and PORT026 in requirements matrix.</li> <li>• Legal disclaimer revised</li> <li>• Release Notes added</li> <li>• “Advice for users” revised</li> <li>• “Revision Information” added</li> </ul>
28.04.2006	2.0.0	AUTOSAR Administration	Document structure adapted to common Release 2.0 SWS Template. <ul style="list-style-type: none"> <li>• Major changes in chapter 10</li> <li>• Structure of document changed partly</li> <li>• Other changes see chapter 11</li> </ul>
30.06.2005	1.0.0	AUTOSAR Administration	Initial Release

## **Disclaimer**

This specification and the material contained in it, as released by AUTOSAR, is for the purpose of information only. AUTOSAR and the companies that have contributed to it shall not be liable for any use of the specification.

The material contained in this specification is protected by copyright and other types of Intellectual Property Rights. The commercial exploitation of the material contained in this specification requires a license to such Intellectual Property Rights.

This specification may be utilized or reproduced without any modification, in any form or by any means, for informational purposes only.  
For any other purpose, no part of the specification may be utilized or reproduced, in any form or by any means, without permission in writing from the publisher.

The AUTOSAR specifications have been developed for automotive applications only. They have neither been developed, nor tested for non-automotive applications.

The word AUTOSAR and the AUTOSAR logo are registered trademarks.

## **Advice for users**

AUTOSAR specifications may contain exemplary items (exemplary reference models, "use cases", and/or references to exemplary technical solutions, devices, processes or software).

Any such exemplary items are contained in the specifications for illustration purposes only, and they themselves are not part of the AUTOSAR Standard. Neither their presence in such specifications, nor any later documentation of AUTOSAR conformance of products actually implementing such exemplary items, imply that intellectual property rights covering such exemplary items are licensed under the same rules as applicable to the AUTOSAR Standard.

## Table of Contents

1	Introduction and functional overview .....	6
2	Acronyms and abbreviations .....	8
3	Related documentation.....	9
3.1	Input documents.....	9
3.2	Related standards and norms .....	9
4	Constraints and assumptions .....	10
4.1	Limitations .....	10
4.2	Applicability to car domains.....	10
5	Dependencies to other modules.....	11
5.1	File structure .....	11
5.1.1	Code file structure .....	11
5.1.2	Header file structure.....	11
6	Requirements traceability .....	14
7	Functional specification .....	23
7.1	General Behaviour .....	23
7.1.1	Background & Rationale .....	23
7.1.2	Requirements.....	23
7.1.2.1	Configuration of Port Pin Properties.....	23
7.1.2.2	Switch port pin direction.....	24
7.1.2.3	Refresh port direction.....	24
7.1.2.4	Configuration of unused Ports and Port Pins .....	24
7.1.2.5	Configuration of symbolic names .....	24
7.1.2.6	Atomicity of port access .....	24
7.1.3	Version Check.....	25
7.1.3.1	Background and Rationale.....	25
7.1.3.2	Requirements.....	25
7.2	Error classification .....	25
7.3	Error detection.....	26
7.4	Error notification .....	26
7.5	API Parameter checking.....	26
7.6	Debugging Support .....	27
8	API specification.....	29
8.1	Imported types.....	29
8.2	Type definitions .....	29
8.2.1	Port_ConfigType .....	29
8.2.2	Port_PinType .....	30
8.2.3	Port_PinDirectionType .....	30
8.2.4	Port_PinModeType .....	30
8.3	Function definitions .....	31
8.3.1	Port_Init.....	31
8.3.2	Port_SetPinDirection.....	33

8.3.3	Port_RefreshPortDirection .....	34
8.3.4	Port_GetVersionInfo.....	34
8.3.5	Port_SetPinMode .....	35
8.4	Call-back notifications .....	36
8.5	Scheduled functions .....	36
8.6	Expected Interfaces.....	36
8.6.1	Mandatory Interfaces .....	36
8.6.2	Optional Interfaces .....	36
8.6.3	Configurable Interfaces .....	36
9	Sequence diagrams .....	37
9.1	Overall Configuration of Ports .....	37
9.2	Set the direction of a Port Pin.....	37
9.3	Refresh the direction of all Port Pins .....	38
9.4	Change the mode of a Port Pin .....	38
10	Configuration specification.....	39
10.1	How to read this chapter .....	39
10.1.1	Configuration and configuration parameters .....	39
10.1.2	Containers.....	39
10.2	Containers and configuration parameters .....	40
10.2.1	Variants.....	40
10.2.2	Port .....	40
10.2.3	PortContainer.....	40
10.2.4	PortGeneral.....	41
10.2.5	PortPin .....	42
10.2.6	PortConfigSet.....	44
10.3	Published Information.....	46
11	Changes to Release 3.0 .....	47
11.1	Deleted SWS Items .....	47
11.2	Replaced SWS Items .....	47
11.3	Changed SWS Items.....	47
11.4	Added SWS Items .....	47
12	Changes to Release 4.0 Rev 1 .....	49
12.1	Deleted SWS Items .....	49
12.2	Replaced SWS Items .....	49
12.3	Changed SWS Items.....	49
12.4	Added SWS Items .....	49

# 1 Introduction and functional overview

This specification specifies the functionality, API and the configuration of the AUTOSAR Basic Software module PORT Driver.

This driver specification is applicable for on-chip ports and port pins.

This module shall provide the service for initializing the whole PORT structure of the microcontroller. Many ports and port pins can be assigned to various functionalities, e.g.

- General purpose I/O
- ADC
- SPI
- SCI
- PWM
- CAN
- LIN
- etc

For this reason, there shall be an overall configuration and initialization of this port structure. The configuration and mode of these port pins is microcontroller and ECU dependent.

Port initialisation data shall be written to each port as efficiently as possible.

This PORT driver module shall complete the overall configuration and initialisation of the port structure which is used in the DIO driver module. Therefore, the DIO driver works on pins and ports which are configured by the PORT driver.

The PORT driver shall be initialised prior to use of the DIO functions. Otherwise DIO functions will exhibit undefined behaviour.

The diagram below identifies the PORT driver functions, and the structure of the PORT driver and DIO driver within the MCAL software layer.

<i>Driver</i>	<i>Name for a Port Pin</i>	<i>Name for Subset of Adjacent pins on one port</i>	<i>Name for a whole port</i>
<b>DIO Driver</b>	Channel	Channel Group	Port
<b>PORT Driver</b>	Port pin	--	Port

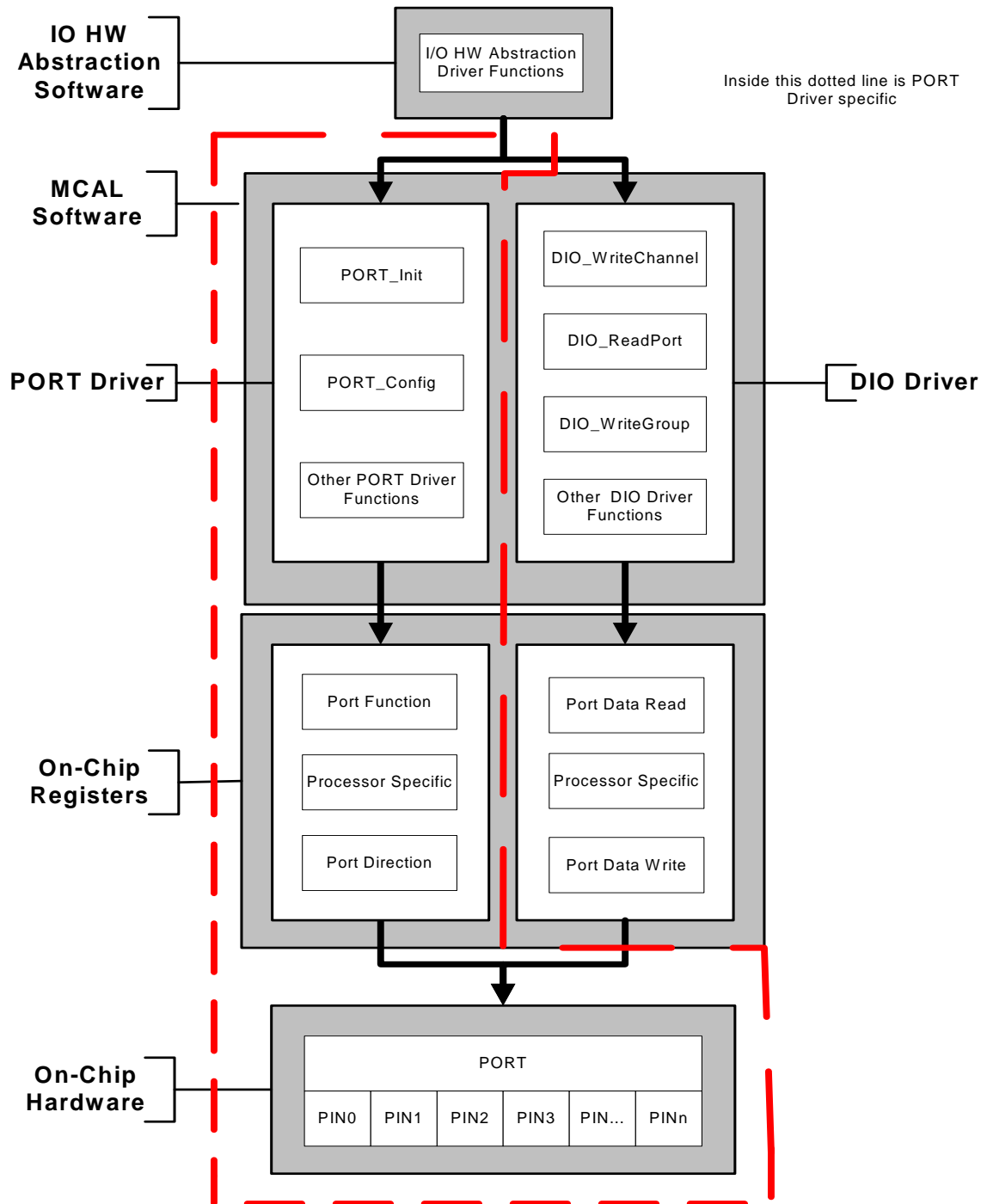

## 2 Acronyms and abbreviations

The following table summarizes the expressions used within the PORT driver.

<b>Abbreviation / Acronym:</b>	<b>Description:</b>
DEM	Diagnostic Event Manager
DET	Development Error Tracer
MCU	MicroController Unit
Port Pin	Represents a single configurable input or output pin on an MCU device.
Port	Represents a whole configurable port on an MCU device.
Physical Level (Input)	Two states are possible: LOW/HIGH
Physical Level (Output)	Two states are possible: LOW/HIGH



### 3 Related documentation

#### 3.1 Input documents

- [1] List of Basic Software Modules,  
AUTOSAR\_TR\_BSWModuleList.pdf
- [2] Layered Software Architecture,  
AUTOSAR\_EXP\_LayeredSoftwareArchitecture.pdf
- [3] General Requirements on Basic Software Modules,  
AUTOSAR\_SRS\_BSWGeneral.pdf
- [4] Specification of Development Error Tracer,  
AUTOSAR\_SWS\_DevelopmentErrorTracer.pdf
- [5] Specification of ECU Configuration,  
AUTOSAR\_TPS\_ECUConfiguration.pdf
- [6] Specification of Diagnostic Event Manager,  
AUTOSAR\_SWS\_DiagnosticEventManager.pdf
- [7] Specification of ECU State Manager,  
AUTOSAR\_SWS\_ECUCStateManager.pdf
- [8] General Requirements on SPAL,  
AUTOSAR\_SRS\_SPALGeneral.pdf
- [9] Requirements on PORT driver,  
AUTOSAR\_SRS\_PORTDriver.pdf
- [10] Specification of Standard Types,  
AUTOSAR\_SWS\_StandardTypes.pdf
- [11] Basic Software Module Description Template,  
AUTOSAR\_TPS\_BSWModuleDescriptionTemplate.pdf

#### 3.2 Related standards and norms

- [12] EC 7498-1 The Basic Model, IEC Norm, 1994

## 4 Constraints and assumptions

### 4.1 Limitations

Limitations for the PORT driver are specified as followed:

- It is the user's responsibility to ensure **that** the same Port/Port pin is not being accessed in parallel by different entities in the same system, e.g. **by** two tasks configuring the same port or two tasks configuring the same pin, or two tasks configuring different pins on the same port.

### 4.2 Applicability to car domains

No restrictions

## 5 Dependencies to other modules

Other driver modules may be dependent on the PORT driver depending on the available functionality of individual port pins on an MCU. For example, an MCU pin may be configurable as a DIO or SPI pin. Therefore, the DIO and/or the SPI driver modules may be dependent on the PORT module to configure the pin for the desired functionality.

### 5.1 File structure

#### 5.1.1 Code file structure

The code file structure shall not be defined within this specification completely.

**PORT108:** The code file structure shall include the following files named:

- `Port_Lcfg.c` – for link time configurable parameters and
- `Port_PBcfg.c` – for post build time configurable parameters.

These files shall contain all link time and post-build time configurable parameters.

#### 5.1.2 Header file structure

**PORT080:** The include file structure of the Port Driver shall be as follows:

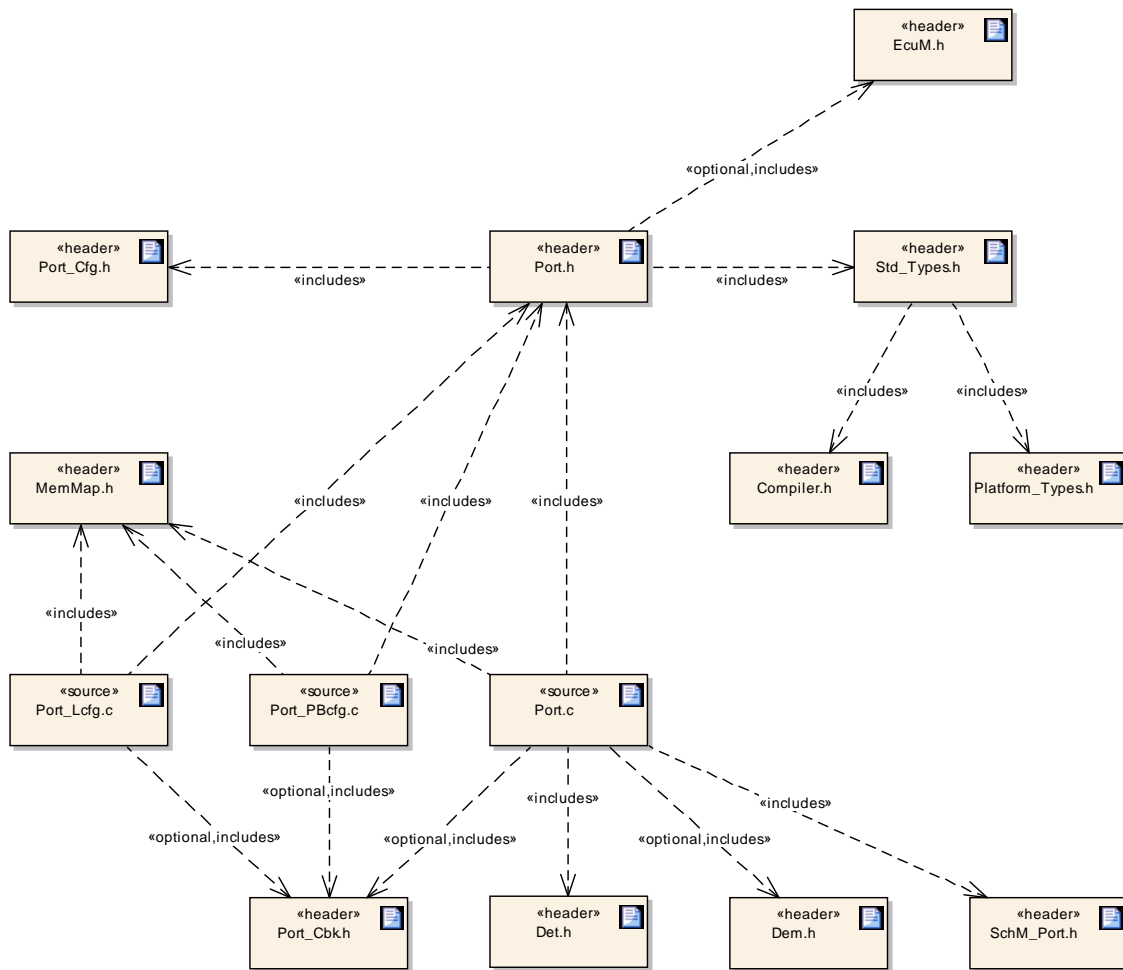

**Figure 1 Header File Structure**

**PORT130:** `Port.h` shall include `Port_Cfg.h` for the API pre-compiler switches, `Std_Types.h` and `EcuM.h`

**PORT131:** `Port.c` shall include `Port.h`, `MemMap.h`, `Det.h`, `SchM_Port.h` (see PORT114 for inclusion checking).

**PORT204:** `Port.c` shall optionally include `Port_Cbk.h` and `Dem.h`

`Port.c` has implicit access to the `Port_Cfg.h` file through the `Port.h` file.

**PORT205:** `Port_Lcfg.c` shall include `MemMap.h` and `Port.h`

**PORT133:** `Port_PBcfg.c` shall include `MemMap.h` and `Port.h`

The implicit include of `Port_Cfg.h` via `Port.h` in the files `Port_Lcfg.c` and `Port_PBcfg.c` is necessary to solve the following construct:

```
Port.h
-----
#ifdef xxx_VERSION_INFO_API
xxx_GetVersionInfo(...)
#endif

Port_Cfg.h
-----
#define xxx_VERSION_INFO_API
```

Note: A separate file type is not required for the PORT driver as the Port Types depend on the platform and are not configurable.

## 6 Requirements traceability

This chapter refers to the input requirements specified in the SRS documents (Software Requirements Specifications) that are applicable for this software module.

The table below lists the specification items of the PORT driver SWS document that satisfy the input requirements. Only functional requirements are referenced.

Document: AUTOSAR requirements on Basic Software, general [\[3\]](#)

<b>Requirement</b>	<b>Satisfied by</b>
[BSW003] Version identification	<a href="#">PORT222</a>
[BSW004] Version check	<a href="#">PORT114</a> , <a href="#">Chapter 7.1.3</a>
[BSW005] No hard coded horizontal interfaces within MCAL	Not applicable (Because architectural AUTOSAR concept is the basis for this concept)
[BSW006] Platform independency	Not applicable (because the module is not above the MCAL)
[BSW007] HIS MISRA C	Not applicable (Because it is requirement on implementation)
[BSW009] Module User Documentation	<a href="#">Section 3.1</a>
[BSW010] Memory resource documentation	Not applicable (Because this is a requirement for the implementer)
[BSW101] Initialization interface	<a href="#">PORT001</a> , <a href="#">PORT002</a> , <a href="#">PORT041</a> , <a href="#">PORT042</a>
[BSW158] Separation of configuration from implementation	<a href="#">Figure 5.1: Header File</a>
[BSW159] Tool-based configuration	<a href="#">PORT004</a>
[BSW160] Human-readable configuration data	Not applicable (Because it only applies to the configuration. Requirement on implementation)
[BSW161] Microcontroller abstraction	Not applicable (Because architectural AUTOSAR concept is the basis for this concept)
[BSW162] ECU layout abstraction	Not applicable (Because architectural AUTOSAR concept is the basis for this concept)
[BSW164] Implementation of interrupt service routines	Not applicable (Because the PORT does not provide interrupt functionality)
[BSW167] Static configuration checking	Not Applicable (Because this is a requirement for the configuration tool).
[BSW168] Diagnostic Interface of SW components	Not applicable (Because the PORT does not provide diagnostic capabilities)
[BSW170] Data for reconfiguration of AUTOSAR SW-Components	Not applicable (Because it only affects the configuration)

[BSW171] Configurability of optional functionality	<a href="#">PORT117 Conf</a> , <a href="#">PORT118 Conf</a>
[BSW172] Compatibility and documentation of scheduling strategy	Not applicable (Because PORT does not have any special scheduling requirements)
[BSW00300] Module naming convention	<a href="#">Figure 5.1</a>
[BSW00301] Limit imported information	<a href="#">Figure 5.1</a>
[BSW00302] Limit exported information	<a href="#">Figure 5.1</a>
[BSW00304] AUTOSAR integer data types	<a href="#">Section 8.2</a>
[BSW00305] Self-defined data types naming convention	<a href="#">Section 8.2</a>
[BSW00306] Avoid direct use of compiler and platform specific keywords	<a href="#">Figure 5.1</a>
[BSW00307] Global variables naming convention	Not applicable (Because it is a requirement on implementation)
[BSW00308] Definition of global data	Not applicable (Because this is a requirement for the implementer)
[BSW00309] Global data with read-only constraint	Not applicable (Req for the implementer)
[BSW00310] API naming convention	<a href="#">Section 8.3</a>
[BSW00312] Shared code shall be reentrant	<a href="#">Section 8.3</a>
[BSW00314] Separation of interrupt frames and service routines	<a href="#">Figure 5.1</a>
[BSW00318] Format of module version numbers	<a href="#">PORT222</a>
[BSW00321] Enumeration of module version numbers	Not applicable (Because this is a requirement for the Implementer)
[BSW00323] API parameter checking	<a href="#">PORT087</a>
[BSW00325] Runtime of interrupt service routines	Not applicable (Because the PORT driver does not provide interrupt capabilities. This is a requirement for implementation)
[BSW00326] Transition from ISRs to OS tasks	Not applicable (Because PORT does not provide interrupt capabilities. This is a requirement on implementation)
[BSW00327] Error values naming convention	<a href="#">PORT051</a>
[BSW00328] Avoid duplication of code	Not applicable (Because this is a requirement for the implementer)
[BSW00329] Avoidance of generic interfaces	Not applicable (Because there are no generic interfaces specified within this SWS)
[BSW00330] Usage of macros / inline functions instead of functions	Not applicable (Because this is a requirement for the implementer)
[BSW00331] Separation of error and status values	Not applicable (Because there are no status values specified within this SWS)

[BSW00333] Documentation of callback function context	Not applicable (Because it is a non functional requirement. There is no callback functionality in the PORT module)
[BSW00334] Provision of XML file	Not applicable (Because this is specified by WP ECU Configuration)
[BSW00335] Status values naming convention	Not applicable (Because there are no status values specified within the SWS)
[BSW00336] Shutdown interface	Not applicable (Because for the PORT driver there is no need for this requirement.)
[BSW00337] Classification of errors	<a href="#">PORT051</a>
[BSW00338] Detection and Reporting of development errors	<a href="#">PORT100</a>
[BSW00339] Reporting of production relevant error status	<a href="#">PORT037</a>
[BSW00341] Microcontroller compatibility documentation	Not applicable (Because this is a requirement for the Implementer)
[BSW00342] Usage of source code and object code	Not applicable (Because it is requirement on implementation)
[BSW00343] Specification and configuration of time	Not applicable (Because it is a non functional requirement. Time configuration is not a requirement of the PORT driver.)
[BSW00344] Reference to Link-time configuration	Not applicable (PORT driver does not support Link-time configuration)
[BSW00345] Pre-compile-time configuration	<a href="#">Figure 5.1: Header File</a> , <a href="#">PORT117_Conf</a>
[BSW00346] Basic set of module files	<a href="#">Figure 5.1: Header File</a>
[BSW00347] Naming separation of different instances of BSW drivers	Not applicable (Because it is a requirement on implementation)
[BSW00348] Standard type header	<a href="#">Figure 5.1</a>
[BSW00350] Development error detection keyword	<a href="#">PORT123_Conf</a>
[BSW00353] Platform specific type header	<a href="#">Figure 5.1</a>
[BSW00355] Do not redefine AUTOSAR integer data types	Not applicable (Because no integer data types are redefined in this specification)
[BSW00357] Standard API return type	Not applicable (Because this type is not used within the SWS)
[BSW00358] Return type of init() functions	<a href="#">Section 8.3.1</a> , <a href="#">PORT140</a>
[BSW00359] Return type of callback functions	Not applicable (Because the PORT module does not provide a callback mechanism)
[BSW00360] Parameters of callback functions	Not applicable (Because the PORT module does not provide a callback mechanism)
[BSW00361] Compiler specific language extension header	<a href="#">Figure 5.1</a>



[BSW00369] Do not return development error codes via API	<a href="#">PORT107</a>
--	-------------------------

[BSW00370] Separation of callback interface from API	Not applicable (Because the PORT driver does not provide a callback mechanism)
[BSW00371] Do not pass function pointers via API	Not applicable (Because no function pointers are passed via API in this SWS)
[BSW00373] Main processing function naming convention	Not applicable (Because it is a non functional requirement. There is no main processing function specified in the PORT driver)
[BSW00374] Module vendor identification	<a href="#">PORT222</a>
[BSW00375] Notification of wake-up reason	Not applicable (Because the PORT driver does not provide a wake-up mechanism)
[BSW00376] Return type and parameters of main processing functions	Not applicable (Because there is no main processing function specified)
[BSW00377] Module specific API return types	Not applicable (Because this type is not used within the SWS)
[BSW00378] AUTOSAR boolean type	Not applicable (data type not defined inside this SWS)
[BSW00379] Module identification	<a href="#">PORT222</a>
[BSW00380] Separate C-File for configuration parameters	<a href="#">Figure 5.1: Header File</a>
[BSW00381] Separate configuration header file for pre-compile time parameters	<a href="#">Figure 5.1: Header File</a>
[BSW00383] List dependencies of configuration files	<a href="#">PORT080, Section 5.1.2</a>
[BSW00384] List dependencies to other modules	<a href="#">PORT080, Section 5.1.2</a>
[BSW00385] List possible error notifications	<a href="#">PORT051</a>
[BSW00386] Configuration for detecting an error	<a href="#">Chapter 7.2.1</a>
[BSW00387] Specify the configuration class of callback function	Not applicable (Because the PORT driver does not have any callback capability).
[BSW00388] Introduce containers	<a href="#">Chapter 10.2</a>
[BSW00389] Containers shall have names	<a href="#">Chapter 10.2</a>
[BSW00390] Parameter content shall be unique within the module	<a href="#">Chapter 8.3</a>
[BSW00391] Parameter shall have unique names	<a href="#">Chapter 8.3</a>
[BSW00392] Parameters shall have a type	<a href="#">Chapter 8.3</a>
[BSW00393] Parameters shall have a range	<a href="#">Chapter 8.3</a>
[BSW00394] Specify the scope of the parameters	<a href="#">Chapter 8.3</a>
[BSW00395] List the required parameters (per parameter)	Not applicable (Because none of the parameters of the PORT driver are dependent on other modules)
[BSW00396] Configuration classes	<a href="#">Chapter 10.2</a>
[BSW00397] Pre-compile-time parameters	<a href="#">PORT117_Conf</a>
[BSW00398] Link-time parameters	Not applicable (No Link-time parameter specified)
[BSW00399] Loadable Post-build time parameters	<a href="#">Chapter 10.2</a>
[BSW00400] Selectable Post-build time parameters	<a href="#">Chapter 10.2</a>
[BSW00401] Documentation of multiple instances of configuration parameters	<a href="#">Chapter 10.2</a>
[BSW00402] Published information	<a href="#">Chapter 10.3</a>
[BSW00404] Reference to post build time configuration	<a href="#">PORT041</a>
[BSW00405] Reference to multiple configuration sets	<a href="#">PORT121_Conf</a>

[BSW00406] Check module initialization	<a href="#">PORT051</a> , <a href="#">PORT087</a> (PORT_E_UNINIT)
[BSW00407] Function to read out published parameters	<a href="#">PORT102</a>
[BSW00408] Configuration parameter naming convention	<a href="#">Chapter 10.2</a>
[BSW00409] Header files for production code error IDs	<a href="#">PORT115</a>
[BSW00410] Compiler switches shall have defined values	<a href="#">Chapter 10.2</a>
[BSW00411] Get version info keyword	<a href="#">PORT103</a>
[BSW00412] Separate H-File for configuration parameters	<a href="#">Figure 5.1: Header file</a>
[BSW00413] Accessing instances of BSW modules	Not applicable (Because this is a requirement on implementation)
[BSW00414] Parameter of init function	<a href="#">PORT121</a>
[BSW00415] User dependent include files	<a href="#">Figure 5.1</a>
[BSW00416] Sequence of Initialization	Not applicable (Because this requirement describes the initialization of the whole SPAL layer).
[BSW00417] Reporting of Error Events by Non-Basic Software	Not applicable (Because this driver is part of the basic software layer. This requirement applies only for non-BSW modules).
[BSW00419] Separate C-Files for pre-compile time configuration parameters	Not applicable C file for pre-compile parameter is not defined in this SWS.
[BSW00420] Production relevant error event rate detection	Not applicable (Because it is a non functional requirement and applies only for DEM)
[BSW00421] Reporting of production relevant error events	Not applicable (Req rejected from the SRS General)
[BSW00422] Debouncing of production relevant error status	<a href="#">PORT037</a>
[BSW00423] Usage of SW-C template to describe BSW modules with AUTOSAR Interfaces	Not applicable (Because it is a non-functional requirement. The PORT driver has no AUTOSAR interface)
[BSW00424] BSW main processing function task allocation	Not applicable (Because the PORT driver does not contain any main processing functions)
[BSW00425] Trigger conditions for schedulable objects	Not applicable (Because the PORT driver does not contain any schedulable objects/services. This is a requirement for the Implementer).
[BSW00426] Exclusive areas in BSW modules	Not applicable (Because applies only for the module descriptions template)
[BSW00427] ISR description for BSW modules	Not applicable (Because this is a requirement for the implementer)
[BSW00428] Execution order dependencies of main processing functions	Not applicable (Because there is no main processing function specified).
[BSW00429] Restricted BSW OS functionality access	Not applicable (Requirement on the implementation )
[BSW00431] The BSW Scheduler module implements task bodies	Not applicable (Because this requirement is for an upper layer. There is no scheduling functionality in the PORT module).

[BSW00432] Modules should have separate main processing functions for read/receive and write/transmit data path	Not applicable (Because the PORT driver does not contain any main processing functions).
[BSW00433] Calling of main processing functions	Not applicable (Because for the PORT driver there is no main processing function specified).
[BSW00434] The Schedule Module shall provide an API for exclusive areas	Not applicable (Because it is a non functional requirement. There is no scheduling functionality in the PORT driver)
[BSW00435] Header files Structure for the Basic Software Scheduler.	See Section <a href="#">5.1.2 (PORT131)</a> )
[BSW00436] Module Header File Structure for the Basic Software Memory Mapping.	See Section <a href="#">5.1.2 (PORT131)</a>
[BSW00437] Nolnit—Area in RAM	Not applicable (Because this is a requirement for the implementer)
[BSW00438] Post build Configuration data Structure	See Section <a href="#">10</a> .
[BSW00439] Declaration of Interrupt Handler and ISR	Not applicable (Port driver does not have Interrupt or Isr to manage)
[BSW00440] Function prototype for callback functions	Not applicable (There aren't callbacks in the Port Driver )
[BSW00442] Debugging Support	<a href="#">PORT200</a> , <a href="#">PORT201</a> <a href="#">PORT202</a> , <a href="#">PORT203</a>

Document: AUTOSAR requirements on SPAL document [8]

<b>Requirement</b>	<b>Satisfied by</b>
[BSW12263] Object code compatible configuration concept	<a href="#">PORT041</a> and <a href="#">Port_ConfigType</a>
[BSW12056] Configuration of notification mechanism	Not Applicable (Because the PORT driver does not include notification functionality).
[BSW12267] Configuration of wakeup sources	Not Applicable (Because there is no wake-up functionality associated to the PORT driver).
[BSW12057] Driver module initialization	<a href="#">PORT041</a> , <a href="#">PORT042</a> , <a href="#">PORT043</a>
[BSW12125] Initialization of hardware resources	<a href="#">PORT041</a> , <a href="#">PORT042</a>
[BSW12163] Driver module deinitialization	<a href="#">PORT003</a>
[BSW12068] MCAL initialization sequence	Not applicable (Because this requirement describes the initialisation of the whole SPAL layer).
[BSW12069] Wake-up notification of ECU State Manager	Not applicable (Because the PORT driver has no wake-up functionality).
[BSW157] Notification mechanisms of drivers and handlers	Not applicable (Because there is no notification functionality associated to the PORT driver.
[BSW12169] Control of operation mode	Not applicable (Because there is no set mode functionality in the PORT driver).
[BSW12063] Raw value mode	Not applicable (Because there is no functionality in the PORT driver for the raw value mode).

[BSW12075] Use of application buffers	Not applicable (Because there is no random streaming capability)
[BSW12129] Resetting of interrupt flags	Not applicable (Because the interrupt functionality is not part of the PORT driver).
[BSW12064] Change of operation mode during running operation	Not applicable (Because this is a non-functional requirement concerning system design).
[BSW12067] Setting of wake-up conditions	Not applicable (Because the PORT driver has no wake-up conditions).
[BSW12448] Behaviour after development error detection	<a href="#">PORT077</a>
[BSW12077] Non-blocking implementation	Not applicable (Because this is a requirement for the implementer)
[BSW12078] Runtime and memory efficiency	Not applicable (Because this is a requirement for the implementer)
[BSW12092] Access to drivers	Not applicable (Because this is a non-functional requirement concerning the system design).
[BSW12265] Configuration data shall be kept constant	Not applicable (Because this is a requirement for the implementer)
[BSW12264] Specification of configuration items	Chapter 10 - Configuration specification.
[BSW12461] Responsibility for register initialisation	<a href="#">PORT113</a> , <a href="#">PORT214</a> , <a href="#">PORT215</a> , <a href="#">PORT217</a> , <a href="#">PORT218</a>
[BSW12462] Provide settings for register initialisation.	Not applicable (Requirement for the implementers)

[BSW12463] Combine and forward settings for register initialisation.	Not applicable (Because this is a requirement for a configuration tool).
--	---

Document: Requirements on PORT Driver SRS [9]

<b>Requirement</b>	<b>Satisfied by</b>
[BSW12001] Configuration of Port Pin Properties	<a href="#">PORT004</a> , <a href="#">PORT079</a> , <a href="#">PORT072</a>
[BSW12302] Configuration of symbolic names	<a href="#">PORT006</a>
[BSW12405] Set port pin direction	<a href="#">PORT063</a> , <a href="#">PORT086</a> , <a href="#">PORT138</a>
[BSW12406] Refresh port direction	<a href="#">PORT060</a> , <a href="#">PORT061</a>
[BSW12300] Configuration of unused port pins	<a href="#">PORT005</a>
[BSW12423] Provide atomicity of port access	<a href="#">PORT075</a>

## 7 Functional specification

### 7.1 General Behaviour

#### 7.1.1 Background & Rationale

**PORT001:** The PORT Driver module shall initialize the whole port structure of the microcontroller.

Note: Defining the order in which the ports and port pins are configured is the task of the configuration tool.

#### 7.1.2 Requirements

##### 7.1.2.1 Configuration of Port Pin Properties

**PORT004:** The PORT Driver module shall allow the configuration of different functionality for each port and port pin, e.g. ADC, SPI, DIO etc.

The configuration of the port (i.e. whole port or single port pin) is microcontroller dependent.

**PORT079:** The PORT Driver module shall provide additional configurations for the MCU port/port pins:

- Pin direction (input/output)
- Pin level initial value
- Pin direction changeable during runtime (yes/no).
- Port mode changeable during runtime.

**PORT081:** The PORT Driver module shall provide a number of optional configurations for the MCU ports and port pins (if supported by hardware):

- Slew rate control
- Activation of internal pull-ups
- Input Thresholds
- Pin driven mode (push-pull / open drain).
- Type of Readback support (pin level, output register value).

**PORT082:** The PORT Driver module shall not provide the facility to configure pin level inversion. The default value shall be set (i.e. not inverted).

Note: The IO Hardware Abstraction layer shall carry out level inversion.

### 7.1.2.2 Switch port pin direction

**PORT137:** For the port pins configured as changeable using the configuration tool, the PORT driver shall allow the user to change the direction of port pins during runtime.

**PORT138:** If the MCU port control hardware provides an output latch for setting the output level on a port pin, switching the port pin direction shall not alter the level set in this output latch.

### 7.1.2.3 Refresh port direction

**PORT066:** For refreshing of the port on the microcontroller, the PORT driver shall allow the user to refresh the direction of those port pins whose direction is set by configuration and cannot be changed dynamically.

### 7.1.2.4 Configuration of unused Ports and Port Pins

**PORT005:** The PORT Driver module shall configure all ports and port pins that are not used (neither as GPIO nor special purpose IO) to be set to a defined state by the PORT Driver module configuration.

### 7.1.2.5 Configuration of symbolic names

**PORT006:** The user of the PORT Driver module shall configure the symbolic names of the port pins of the MCU.

**PORT207:** These symbolic names for the individual port pins (e.g. PORT\_A\_PIN\_0) shall be defined in the configuration tool.

**PORT076:** The PORT Driver module's implementer shall define symbolic names in the file `Port_Cfg.h`

**PORT208:** The PORT Driver module's implementer shall publish the symbolic names through the file `Port.h`

### 7.1.2.6 Atomicity of port access

**PORT075:** The PORT Driver module shall provide atomic access to all ports and port pins.

Note:

An atomic access is a non interruptible access to Microcontroller registers by the use of either atomic instructions or the usage of an exclusive area (interrupt disabling for example) provided by the basic software scheduler module.



### 7.1.3 Version Check

#### 7.1.3.1 Background and Rationale

The integration of incompatible files shall be avoided. Minimum implementation is the version check of the header file inside the .c file (version numbers of .c and .h files shall be identical).

#### 7.1.3.2 Requirements

The Port module shall avoid the integration of incompatible files by the following pre-processor checks:

##### **PORT114:**

For included (external) header files,

- <MODULENAME>\_AR\_RELEASE\_MAJOR\_VERSION
- <MODULENAME>\_AR\_RELEASE\_MINOR\_VERSION

shall be verified.

## 7.2 Error classification

**PORT115:** Values for production code Event Ids are assigned externally by the configuration of the DEM. They are published in the file `Dem_IntErrId.h` and included via `Dem.h`.

By this inclusion the APIs to report errors as well as the required Event Id symbols are included. This specification defines the name of the Event Id symbols which are provided by XML to the DEM configuration tool. The DEM configuration tool assigns ECU dependent values to the Event Id symbols and publishes the symbols in `Dem_IntErrId.h`.

**PORT116:** Development error values are of type `uint8`.

**PORT051:** The following errors and exceptions shall be detectable by the PORT driver depending on its build version (development/production).

<i>Type or error</i>	<i>Relevance</i>	<i>Related error code</i>	<i>Value</i>
Invalid Port Pin ID requested	Development	PORT_E_PARAM_PIN	0x0A
Port Pin not configured as changeable	Development	PORT_E_DIRECTION_UNCHANGEABLE	0x0B
API Port_Init service	Development	PORT_E_PARAM_CONFIG	0x0C

called with wrong parameter.			
API Port_SetPinMode service called when mode is unchangeable.	Development	PORT_E_PARAM_INVALID_MODE	0x0D
		PORT_E_MODE_UNCHANGEABLE	0x0E
API service called without module initialization	Development	PORT_E_UNINIT	0x0F
APIs called with a Null Pointer	Development	PORT_E_PARAM_POINTER	0x10

### 7.3 Error detection

**PORT100:** The detection of development errors is configurable (ON/OFF) at pre-compile time.

**PORT211:** The switch `PortDevErrorDetect` (see Chapter 10) shall activate or deactivate the detection of all development errors.

**PORT101:** If the `PortDevErrorDetect` switch is enabled, API parameter checking is enabled. The detailed description of the detected errors can be found in Chapter 7.2 and Chapter 8.

**PORT139:** The detection of production code errors cannot be switched off.

### 7.4 Error notification

**PORT037:** Production errors shall be reported to the Diagnostic Event Manager [\[Ref.6\]](#).

**PORT038:** If it is possible to detect additional errors, because of specific implementation and/or specific hardware properties, then the PORT module's implementer shall add them to the PORT implementation specification. The classification and enumeration shall be compatible to the errors listed above [PORT051].

**PORT107:** Detected development errors shall be reported to the `Det_ReportError` service of the Development Error Tracer (DET) if the pre-processor switch `PortDevErrorDetect` is set (see Chapter 10).

### 7.5 API Parameter checking

**PORT077:** If development error detection is enabled the Port Driver module shall check the function parameters in the order in which they are passed and skip further parameter checking if one check fails.

Example: For the function `Port_SetPinDirection`, the first parameter to be passed is the pin ID. This parameter shall identify the relevant port pin of the MCU's

port. The second parameter passed corresponds to the direction to change on the port pin.

**PORT087:** If development error detection is enabled and the Port Driver module has detected an error, the desired functionality shall be skipped and the requested service shall return without any action.

See table below for a list of the Det errors returned by each function.

<b>Function</b>	<b>Error Condition</b>	<b>Related error value</b>
Port_SetPinDirection	Incorrect Port Pin ID passed	PORT_E_PARAM_PIN
	Port Pin not configured as changeable	PORT_E_DIRECTION_UNCHANGEABLE
Port_Init	Port_Init service called with wrong parameter.	PORT_E_PARAM_CONFIG
Port_SetPinMode	Incorrect Port Pin ID passed	PORT_E_PARAM_PIN
	Port Pin Mode passed not valid	PORT_E_PARAM_INVALID_MODE
	Port_SetPinMode service called when the mode is unchangeable	PORT_E_MODE_UNCHANGEABLE
Port_SetPinDirection, Port_SetPinMode Port_GetVersionInfo Port_RefreshPortDirection	API service called prior to module initialization	PORT_E_UNINIT
Port_GetVersionInfo	Api called with a NULL Pointer Parameter	PORT_E_PARAM_POINTER

## 7.6 Debugging Support

The following requirements deal with the definition of variables and the description of debug information.

PORT200: Each variable that shall be accessible by AUTOSAR Debugging shall be defined as global variable.

PORT201: All type definitions of variables that shall be debugged, shall be accessible by the header file Port.h.

PORT202: The declaration of variables in the header file shall allow to calculate the size of the variables by C-"sizeof".

PORT203: Variables available for debugging shall be described in the respective Basic Software Module Description.



## 8 API specification

### 8.1 Imported types

In this chapter, all types included from the following files are listed:

**PORT129:**

<i>Module</i>	<i>Imported Type</i>
Dem	Dem_EventIdType
	Dem_EventStatusType
Std_Types	Std_ReturnType
	Std_VersionInfoType

### 8.2 Type definitions

#### 8.2.1 Port\_ConfigType

<b>Name:</b>	Port_ConfigType	
<b>Type:</b>	Structure	
<b>Range:</b>	Hardware Dependent Structure	The contents of the initialization data structure are specific to the microcontroller.
<b>Description:</b>	Type of the external data structure containing the initialization data for this module.	

**PORT073:** The type `Port_ConfigType` is a type for the external data structure containing the initialization data for the PORT Driver.

Note: The user shall use the symbolic names defined in the configuration tool.

Note: The configuration of each port pin is MCU specific. Therefore, it is not possible to include a complete list of different configurations in this specification.

**PORT072:** A list of possible port configurations for the structure `Port_ConfigType` is given below:

- Pin mode (e.g. DIO, ADC, SPI ...) – this port pin configuration is mandatory unless the port pin is configured for DIO.
- Pin direction (input, output) – this port pin configuration is mandatory when the port pin is to be used for DIO.
- Pin level init value (see [PORT055](#)) – this port pin configuration is mandatory when the port pin is used for DIO.

- Pin direction changeable during runtime (STD\_ON/STD\_OFF) – this port pin configuration is MCU dependent.
- Pin mode changeable during runtime (STD\_ON/STD\_OFF) – configuration is MCU dependent.

Optional parameters (if supported by hardware)

- Slew rate control.
- Activation of internal pull-ups.
- Microcontroller specific port pin properties.

### 8.2.2 Port\_PinType

<b>Name:</b>	Port_PinType	
<b>Type:</b>	uint	
<b>Range:</b>	0 - <number of port pins:>	Shall cover all available port pins. The type should be chosen for the specific MCU platform (best performance).
<b>Description:</b>	Data type for the symbolic name of a port pin.	

**PORT013:** The type `Port_PinType` shall be used for the symbolic name of a Port Pin.

**PORT219:** The type `Port_PinType` shall be `uint8`, `uint16` or `uint32` based on the specific MCU platform.

Note: The user shall use the symbolic names provided by the configuration tool.

### 8.2.3 Port\_PinDirectionType

<b>Name:</b>	Port_PinDirectionType	
<b>Type:</b>	Enumeration	
<b>Range:</b>	PORT_PIN_IN	Sets port pin as input.
	PORT_PIN_OUT	Sets port pin as output.
<b>Description:</b>	Possible directions of a port pin.	

**PORT046:** The type `Port_PinDirectionType` is a type for defining the direction of a Port Pin.

**PORT220:** The type `Port_PinDirectionType` shall be of enumeration type having range as `PORT_PIN_IN` and `PORT_PIN_OUT`.

### 8.2.4 Port\_PinModeType

<b>Name:</b>	Port_PinModeType
--------------	------------------

<b>Type:</b>	uint	
<b>Range:</b>	Implementation specific	As several port pin modes shall be configurable on one pin, the range shall be determined by the implementation.
<b>Description:</b>	Different port pin modes.	

**PORT124:** A port pin shall be configurable with a number of port pin modes (type `Port_PinModeType`).

**PORT212:** The type `Port_PinModeType` shall be used with the function call `Port_SetPinMode` (see Section 8.3.5).

**PORT221:** The type `Port_PinModeType` shall be `uint8`, `uint16` or `uint32`.

## 8.3 Function definitions

This is a list of functions provided for upper layer modules.

### 8.3.1 Port\_Init

#### PORT140:

<b>Service name:</b>	Port_Init	
<b>Syntax:</b>	<pre>void Port_Init(     const Port_ConfigType* ConfigPtr )</pre>	
<b>Service ID[hex]:</b>	0x00	
<b>Sync/Async:</b>	Synchronous	
<b>Reentrancy:</b>	Non Reentrant	
<b>Parameters (in):</b>	ConfigPtr	Pointer to configuration set.
<b>Parameters (inout):</b>	None	
<b>Parameters (out):</b>	None	
<b>Return value:</b>	None	
<b>Description:</b>	Initializes the Port Driver module.	

**PORT041:** The function `Port_Init` shall initialize ALL ports and port pins with the configuration set pointed to by the parameter `ConfigPtr`.

**PORT078:** The Port Driver module's environment shall call the function `Port_Init` first in order to initialize the port for use.

**PORT213:** If `Port_Init` function is not called first, then no operation can occur on the MCU ports and port pins.

**PORT042:** The function `Port_Init` shall initialize all configured resources.

The function `Port_Init` shall apply the following rules regarding initialisation of controller registers.

- **PORT113:** If the hardware allows for only one usage of the register, the driver module implementing that functionality is responsible for initializing the register.
- **PORT214:** If the register can affect several hardware modules and if it is an I/O register it shall be initialised by this PORT driver.
- **PORT215:** If the register can affect several hardware modules and if it is not an I/O register, it shall be initialised by the MCU driver.
- **PORT217:** One-time writable registers that require initialisation directly after reset shall be initialised by the startup code.
- **PORT218:** All the other registers not mentioned before, shall be initialised by the start-up code.

**PORT043:** The function `Port_Init` shall avoid glitches and spikes on the affected port pins.

**PORT071:** The Port Driver module's environment shall call the function `Port_Init` after a reset in order to reconfigure the ports and port pins of the MCU.

**PORT002:** The function `Port_Init` shall initialize all variables used by the PORT driver module to an initial state.

**PORT003:** The Port Driver module's environment may also use the function `Port_Init` to initialize the driver software and reinitialize the ports and port pins to another configured state depending on the configuration set passed to this function.

Note: In some cases, MCU port control hardware provides an output latch for setting the output level on a port pin that may be used as a DIO port pin.

**PORT055:** The function `Port_Init` shall set the port pin output latch to a default level (defined during configuration) before setting the port pin direction to output.

Requirement PORT055 ensures that the default level is immediately output on the port pin when it is set to an output port pin.

Example: On some MCU's, after a power-on-reset, a DIO configurable port pin will be configured as an input pin. If the required configuration of the port pin is an output pin, then the function `Port_Init` shall ensure that the default level is set before switching the functionality of the port pin from input to output.

**PORT105:** If development error detection for the Port Driver module is enabled: In case the function `Port_Init` is called with a NULL `ConfigPtr` and if a variant containing postbuild multiple selectable configuration parameters is used (`VARIANT-POST-BUILD`), the function `Port_Init` shall raise the development error `PORT_E_PARAM_CONFIG` and return without any action.



**PORT121:** The function `Port_Init` shall always have a pointer as a parameter, even though for the configuration variant `VARIANT-PRE-COMPILE`, no configuration set shall be given. In this case, the Port Driver module's environment shall pass a `NULL` pointer to the function `Port_Init`.

The Port Driver module's environment shall not call the function `Port_Init` during a running operation. This shall only apply if there is more than one caller of the `PORT` module.

Configuration of `Port_Init`: All port pins and their functions, and alternate functions shall be configured by the configuration tool.

### 8.3.2 Port\_SetPinDirection

#### PORT141:

<b>Service name:</b>	Port_SetPinDirection	
<b>Syntax:</b>	<pre>void Port_SetPinDirection(     Port_PinType Pin,     Port_PinDirectionType Direction )</pre>	
<b>Service ID[hex]:</b>	0x01	
<b>Sync/Async:</b>	Synchronous	
<b>Reentrancy:</b>	Reentrant	
<b>Parameters (in):</b>	Pin	Port Pin ID number
	Direction	Port Pin Direction
<b>Parameters (inout):</b>	None	
<b>Parameters (out):</b>	None	
<b>Return value:</b>	None	
<b>Description:</b>	Sets the port pin direction	

**PORT063:** The function `Port_SetPinDirection` shall set the port pin direction during runtime.

**PORT054:** The function `Port_SetPinDirection` shall be re-entrant if accessing different pins independent of a port.

**PORT086:** The function `Port_SetPinDirection` shall only be available to the user if the pre-compile parameter `PortSetPinDirectionApi` is set to `TRUE`. If set to `FALSE`, the function `Port_SetPinDirection` is not available. (see also section 8.3.2).

Configuration of `Port_SetPinDirection`: All ports and port pins shall be configured by the configuration tool. See [PORT117](#).

### 8.3.3 Port\_RefreshPortDirection

#### PORT142:

<b>Service name:</b>	Port_RefreshPortDirection
<b>Syntax:</b>	void Port_RefreshPortDirection( void )
<b>Service ID[hex]:</b>	0x02
<b>Sync/Async:</b>	Synchronous
<b>Reentrancy:</b>	Non Reentrant
<b>Parameters (in):</b>	None
<b>Parameters (inout):</b>	None
<b>Parameters (out):</b>	None
<b>Return value:</b>	None
<b>Description:</b>	Refreshes port direction.

**PORT060:** The function `Port_RefreshPortDirection` shall refresh the direction of all configured ports to the configured direction (`PortPinDirection`).

**PORT061:** The function `Port_RefreshPortDirection` shall exclude those port pins from refreshing that are configured as ‘pin direction changeable during runtime’.

The configuration tool shall provide names for each configured port pin.

### 8.3.4 Port\_GetVersionInfo

#### PORT143:

<b>Service name:</b>	Port_GetVersionInfo
<b>Syntax:</b>	void Port_GetVersionInfo( Std_VersionInfoType* versioninfo )
<b>Service ID[hex]:</b>	0x03
<b>Sync/Async:</b>	Synchronous
<b>Reentrancy:</b>	Non Reentrant
<b>Parameters (in):</b>	None
<b>Parameters (inout):</b>	None
<b>Parameters (out):</b>	versioninfo   Pointer to where to store the version information of this module.
<b>Return value:</b>	None
<b>Description:</b>	Returns the version information of this module.

**PORT102:** The function `Port_GetVersionInfo` shall return the version information of this module. The version information includes:

- Module Id
- Vendor Id
- Vendor specific version numbers (BSW00407).

**PORT103:** The function `Port_GetVersionInfo` shall be pre compile time configurable On/Off by the configuration parameter `PortVersionInfoApi`.

**PORT144:** If source code for caller and callee of `Port_GetVersionInfo` is available, the PORT Driver module should realize `Port_GetVersionInfo` as a macro, defined in the module's header file.

**PORT225:** if Det is enabled, the parameter `versioninfo` shall be checked for being NULL. The error `PORT_E_PARAM_POINTER` shall be reported in case the value is a NULL pointer.

### 8.3.5 Port\_SetPinMode

**PORT145:**

<b>Service name:</b>	Port_SetPinMode	
<b>Syntax:</b>	<pre>void Port_SetPinMode(     Port_PinType Pin,     Port_PinModeType Mode )</pre>	
<b>Service ID[hex]:</b>	0x04	
<b>Sync/Async:</b>	Synchronous	
<b>Reentrancy:</b>	Reentrant	
<b>Parameters (in):</b>	Pin	Port Pin ID number
	Mode	New Port Pin mode to be set on port pin.
<b>Parameters (inout):</b>	None	
<b>Parameters (out):</b>	None	
<b>Return value:</b>	None	
<b>Description:</b>	Sets the port pin mode.	

**PORT125:** The function `Port_SetPinMode` shall set the port pin mode of the referenced pin during runtime.

**PORT128:** The function `Port_SetPinMode` shall be re-entrant if accessing different pins, independent of a port.

**PORT223:** If Det is enabled, the function `Port_SetPinMode` shall return `PORT_E_MODE_UNCHANGEABLE` and return without any action, if the parameter `PortPinModeChangeable` is set to `FALSE`.

Configuration of `Port_SetPinMode`: All ports and port pins shall be configured by the configuration tool. See [PORT117](#).

## 8.4 Call-back notifications

There are no callback notifications from the PORT driver. The callback notifications are implemented in another module (ICU Driver and/or complex drivers).

## 8.5 Scheduled functions

There are no scheduled functions within the PORT Driver.

## 8.6 Expected Interfaces

In this chapter, all interfaces required from other modules are listed.

### 8.6.1 Mandatory Interfaces

None

### 8.6.2 Optional Interfaces

This chapter defines all interfaces which are required to fulfill an optional functionality of the module.

#### PORT146:

<i>API function</i>	<i>Description</i>
Dem_ReportErrorStatus	Queues the reported events from the BSW modules (API is only used by BSW modules). The interface has an asynchronous behavior, because the processing of the event is done within the Dem main function.
Det_ReportError	Service to report development errors.

### 8.6.3 Configurable Interfaces

None

## 9 Sequence diagrams

### 9.1 Overall Configuration of Ports

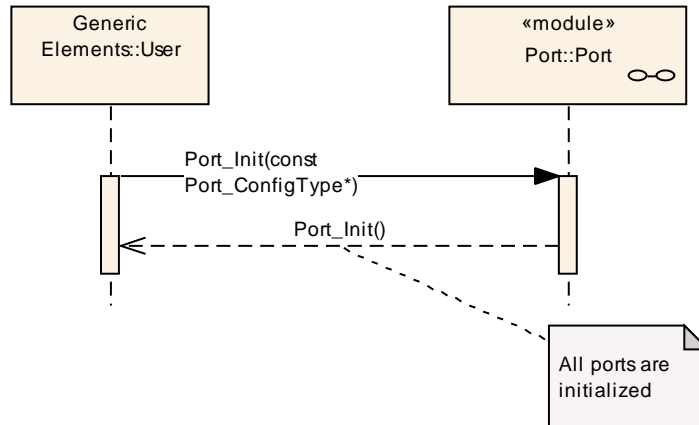

### 9.2 Set the direction of a Port Pin

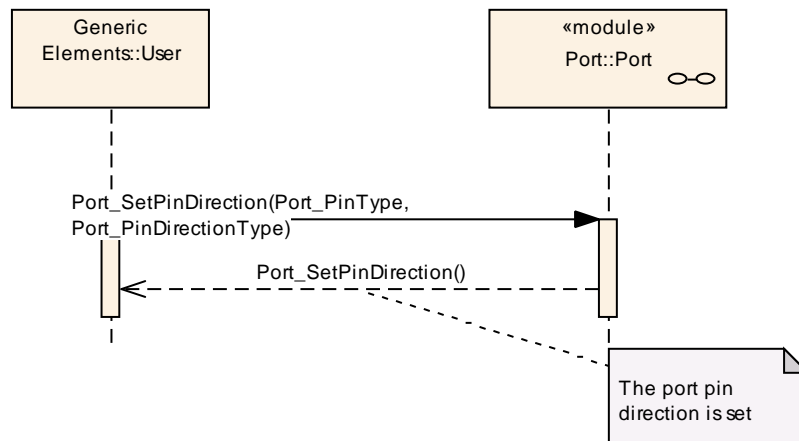

### 9.3 Refresh the direction of all Port Pins

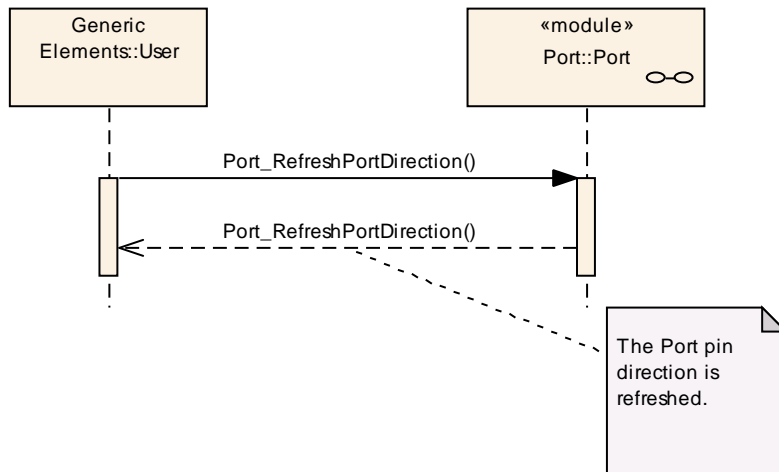

### 9.4 Change the mode of a Port Pin

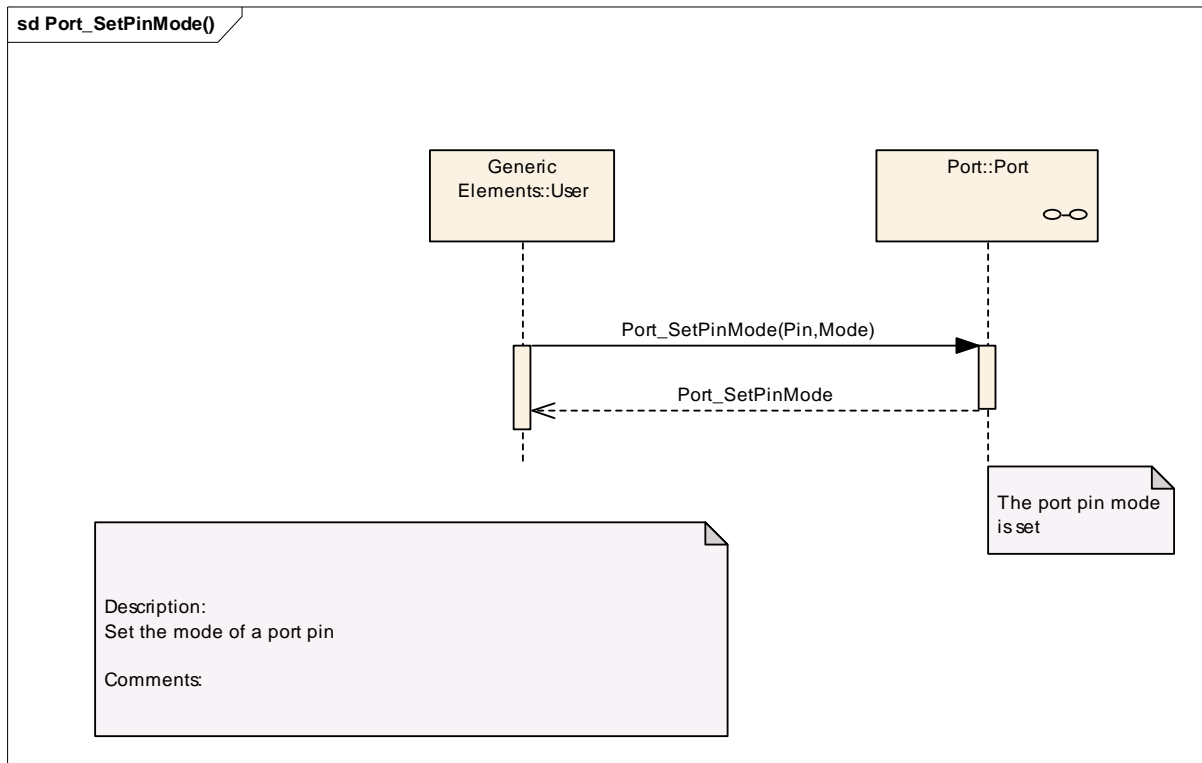

## 10 Configuration specification

In general, this chapter defines configuration parameters and their clustering into containers. In order to support the specification Chapter 10.1 describes fundamentals. It also specifies a template (table) you shall use for the parameter specification. We intend to leave Chapter 10.1 in the specification to guarantee comprehension.

Chapter [10.2](#) specifies the structure (containers) and the parameters of the module PORT

Chapter [10.3](#) specifies published information of the module PORT.

### 10.1 How to read this chapter

In addition to this section, it is highly recommended to read the documents:

- AUTOSAR Layered Software Architecture [\[2\]](#).
- AUTOSAR ECU Configuration Specification [\[5\]](#)  
This document describes the AUTOSAR configuration methodology and the AUTOSAR configuration metamodel in detail.

The following is only a short survey of the topic and it will not replace the ECU Configuration Specification document.

#### 10.1.1 Configuration and configuration parameters

Configuration parameters define the variability of the generic part(s) of an implementation of a module. This means that only generic or configurable module implementation can be adapted to the environment (software/hardware) in use during system and/or ECU configuration.

The configuration of parameters can be achieved at different times during the software process: before compile time, before link time or after build time. In the following, the term “configuration class” (of a parameter) shall be used in order to refer to a specific configuration point in time.

#### 10.1.2 Containers

Containers structure the set of configuration parameters. This means:

- *all* configuration parameters are kept in containers.

(sub-) containers can reference (sub-) containers. It is possible to assign a multiplicity to these references. The multiplicity then defines the possible number of instances of the contained parameters.

## 10.2 Containers and configuration parameters

The following chapters summarize all configuration parameters. The detailed meanings of the parameters describe Chapters 7 and Chapter 8.

### 10.2.1 Variants

#### PORT147: VARIANT-PRE-COMPILE.

Only parameters with "Pre-compile time" configuration are allowed in this variant. The intention of this variant is to optimize the parameters configuration for a source code delivery.

#### PORT148: VARIANT-POST-BUILD.

Parameters with "Pre-compile time", "Link time" and "Post-build time" are allowed in this variant.

The intention of this variant is to optimize the parameters configuration for a reloadable binary.

### 10.2.2 Port

<b>Module Name</b>	Port
<b>Module Description</b>	Configuration of the Port module.

Included Containers		
Container Name	Multiplicity	Scope / Dependency
PortConfigSet	1	This container is the base of a multiple configuration set
PortGeneral	1	Module wide configuration parameters of the PORT driver.

### 10.2.3 PortContainer

<b>SWS Item</b>	PORT122_Conf :	
<b>Container Name</b>	PortContainer	
<b>Description</b>	Container collecting the PortPins.	
<b>Configuration Parameters</b>		

<b>SWS Item</b>	PORT124_Conf :		
<b>Name</b>	PortNumberOfPortPins		
<b>Description</b>	The number of specified PortPins in this PortContainer.		
<b>Multiplicity</b>	1		
<b>Type</b>	EcucIntegerParamDef		
<b>Range</b>	1 .. 65535		
<b>Default value</b>	--		
<b>ConfigurationClass</b>	<b>Pre-compile time</b>	X	All Variants
	<b>Link time</b>	--	
	<b>Post-build time</b>	--	
<b>Scope / Dependency</b>			



<b>Included Containers</b>		
<b>Container Name</b>	<b>Multiplicity</b>	<b>Scope / Dependency</b>
PortPin	1..*	Configuration of the individual port pins.

## 10.2.4 PortGeneral

<b>SWS Item</b>	<b>PORT117_Conf :</b>		
<b>Container Name</b>	PortGeneral{PORT General configuration}		
<b>Description</b>	Module wide configuration parameters of the PORT driver.		
<b>Configuration Parameters</b>			

<b>SWS Item</b>	<b>PORT123_Conf :</b>		
<b>Name</b>	PortDevErrorDetect {PORT_DEV_ERROR_DETECT}		
<b>Description</b>	Switches the Development Error Detection and Notification on or off. true: Enabled. false: Disabled.		
<b>Multiplicity</b>	1		
<b>Type</b>	EcucBooleanParamDef		
<b>Default value</b>	--		
<b>ConfigurationClass</b>	<b>Pre-compile time</b>	X	All Variants
	<b>Link time</b>	--	
	<b>Post-build time</b>	--	
<b>Scope / Dependency</b>	scope: Module		

<b>SWS Item</b>	<b>PORT131_Conf :</b>		
<b>Name</b>	PortSetPinDirectionApi {PORT_SET_PIN_DIRECTION_API}		
<b>Description</b>	Pre-processor switch to enable / disable the use of the function Port_SetPinDirection(). TRUE: Enabled - Function Port_SetPinDirection() is available. FALSE: Disabled - Function Port_SetPinDirection() is not available.		
<b>Multiplicity</b>	1		
<b>Type</b>	EcucBooleanParamDef		
<b>Default value</b>	--		
<b>ConfigurationClass</b>	<b>Pre-compile time</b>	X	All Variants
	<b>Link time</b>	--	
	<b>Post-build time</b>	--	
<b>Scope / Dependency</b>	scope: Module		

<b>SWS Item</b>	<b>PORT132_Conf :</b>		
<b>Name</b>	PortSetPinModeApi {PORT_SET_PIN_MODE_API}		
<b>Description</b>	Pre-processor switch to enable / disable the use of the function Port_SetPinMode(). true: Enabled - Function Port_SetPinMode() is available. false: Disabled - Function Port_SetPinMode() is not available.		
<b>Multiplicity</b>	1		
<b>Type</b>	EcucBooleanParamDef		
<b>Default value</b>	--		
<b>ConfigurationClass</b>	<b>Pre-compile time</b>	X	All Variants
	<b>Link time</b>	--	
	<b>Post-build time</b>	--	
<b>Scope / Dependency</b>	scope: Module		

<b>SWS Item</b>	<b>PORT133_Conf :</b>		
<b>Name</b>	PortVersionInfoApi {PORT_VERSION_INFO_API}		
<b>Description</b>	Pre-processor switch to enable / disable the API to read out the modules version information. true: Version info API enabled. false: Version info API disabled.		
<b>Multiplicity</b>	1		
<b>Type</b>	EcucBooleanParamDef		
<b>Default value</b>	--		
<b>ConfigurationClass</b>	<b>Pre-compile time</b>	X	All Variants
	<b>Link time</b>	--	
	<b>Post-build time</b>	--	
<b>Scope / Dependency</b>	scope: Module		

**No Included Containers**

The top level Port Driver container holds parameters that apply to the PORT configuration.

### 10.2.5 PortPin

<b>SWS Item</b>	<b>PORT118_Conf :</b>		
<b>Container Name</b>	PortPin		
<b>Description</b>	Configuration of the individual port pins.		
<b>Configuration Parameters</b>			

<b>SWS Item</b>	<b>PORT125_Conf :</b>		
<b>Name</b>	PortPinDirection {PORT_PIN_DIRECTION}		
<b>Description</b>	The initial direction of the pin (IN or OUT). If the direction is not changeable, the value configured here is fixed. The direction must match the pin mode. E.g. a pin used for an ADC must be configured to be an in port. Implementation Type: Port_PinDirectionType		
<b>Multiplicity</b>	1		
<b>Type</b>	EcucEnumerationParamDef		
<b>Range</b>	PORT_PIN_IN	Port Pin direction set as input	
	PORT_PIN_OUT	Port Pin direction set as output	
<b>ConfigurationClass</b>	<b>Pre-compile time</b>	X	VARIANT-PRE-COMPILE
	<b>Link time</b>	--	
	<b>Post-build time</b>	X	VARIANT-POST-BUILD
<b>Scope / Dependency</b>	scope: Module		

<b>SWS Item</b>	<b>PORT126_Conf :</b>		
<b>Name</b>	PortPinDirectionChangeable {PORT_PIN_DIRECTION_CHANGEABLE}		
<b>Description</b>	Parameter to indicate if the direction is changeable on a port pin during runtime. true: Port Pin direction changeable enabled. false: Port Pin direction changeable disabled.		
<b>Multiplicity</b>	1		
<b>Type</b>	EcucBooleanParamDef		
<b>Default value</b>	--		
<b>ConfigurationClass</b>	<b>Pre-compile time</b>	X	VARIANT-PRE-COMPILE
	<b>Link time</b>	--	
	<b>Post-build time</b>	X	VARIANT-POST-BUILD
<b>Scope / Dependency</b>	scope: Module		

<b>SWS Item</b>	<b>PORT127_Conf :</b>		
<b>Name</b>	PortPinId		

<b>Description</b>	Pin Id of the port pin. This value will be assigned to the symbolic name derived from the port pin container short name.		
<b>Multiplicity</b>	1		
<b>Type</b>	EcucIntegerParamDef (Symbolic Name generated for this parameter)		
<b>Range</b>	1 .. 65535		
<b>Default value</b>	--		
<b>ConfigurationClass</b>	<b>Pre-compile time</b>	X	All Variants
	<b>Link time</b>	--	
	<b>Post-build time</b>	--	
<b>Scope / Dependency</b>	scope: Module		

<b>SWS Item</b>	<b>PORT128_Conf :</b>		
<b>Name</b>	PortPinInitialMode {PORT_PIN_INITIAL_MODE}		
<b>Description</b>	Port pin mode from mode list for use with Port_Init() function.		
<b>Multiplicity</b>	1		
<b>Type</b>	EcucEnumerationParamDef		
<b>Range</b>	PORT_PIN_MODE_ADC		Port Pin used by ADC
	PORT_PIN_MODE_CAN		Port Pin used for CAN
	PORT_PIN_MODE_DIO		Port Pin configured for DIO. It shall be used under control of the DIO driver.
	PORT_PIN_MODE_DIO_GPT		Port Pin configured for DIO. It shall be used under control of the general purpose timer driver.
	PORT_PIN_MODE_DIO_WDG		Port Pin configured for DIO. It shall be used under control of the watchdog driver.
	PORT_PIN_MODE_FLEXRAY		Port Pin used for FlexRay
	PORT_PIN_MODE_ICU		Port Pin used by ICU
	PORT_PIN_MODE_LIN		Port Pin used for LIN
	PORT_PIN_MODE_MEM		Port Pin used for external memory under control of a memory driver.
	PORT_PIN_MODE_PWM		Port Pin used by PWM
	PORT_PIN_MODE_SPI		Port Pin used by SPI
<b>ConfigurationClass</b>	<b>Pre-compile time</b>	X	VARIANT-PRE-COMPILE
	<b>Link time</b>	--	
	<b>Post-build time</b>	X	VARIANT-POST-BUILD
<b>Scope / Dependency</b>	scope: Module		

<b>SWS Item</b>	<b>PORT129_Conf :</b>		
<b>Name</b>	PortPinLevelValue {PORT_PIN_LEVEL_VALUE}		
<b>Description</b>	Port Pin Level value from Port pin list.		
<b>Multiplicity</b>	1		
<b>Type</b>	EcucEnumerationParamDef		
<b>Range</b>	PORT_PIN_LEVEL_HIGH		Port Pin level is High
	PORT_PIN_LEVEL_LOW		Port Pin level is LOW
<b>ConfigurationClass</b>	<b>Pre-compile time</b>	X	VARIANT-PRE-COMPILE
	<b>Link time</b>	--	
	<b>Post-build time</b>	X	VARIANT-POST-BUILD
<b>Scope / Dependency</b>	scope: Module		

<b>SWS Item</b>	<b>PORT130_Conf :</b>		
<b>Name</b>	PortPinMode {PORT_PIN_MODE}		
<b>Description</b>	Port pin mode from mode list. Note that more than one mode is allowed by		

	default. That way it is e.g. possible to combine DIO with another mode such as ICU. More HW specific literals may be added by module implementor. E.g. SPI may be further broken down into SpiCsHw, SpiCsSw, etc. if necessary.	
<b>Multiplicity</b>	1..*	
<b>Type</b>	EcucEnumerationParamDef	
<b>Range</b>	PORT_PIN_MODE_ADC	Port Pin used by ADC
	PORT_PIN_MODE_CAN	Port Pin used for CAN
	PORT_PIN_MODE_DIO	Port Pin configured for DIO. It shall be used under control of the DIO driver.
	PORT_PIN_MODE_DIO_GPT	Port Pin configured for DIO. It shall be used under control of the general purpose timer driver.
	PORT_PIN_MODE_DIO_WDG	Port Pin configured for DIO. It shall be used under control of the watchdog driver.
	PORT_PIN_MODE_FLEXRAY	Port Pin used for FlexRay
	PORT_PIN_MODE_ICU	Port Pin used by ICU
	PORT_PIN_MODE_LIN	Port Pin used for LIN
	PORT_PIN_MODE_MEM	Port Pin used for external memory under control of a memory driver.
	PORT_PIN_MODE_PWM	Port Pin used by PWM
	PORT_PIN_MODE_SPI	Port Pin used by SPI
<b>ConfigurationClass</b>	<b>Pre-compile time</b>	X VARIANT-PRE-COMPILE
	<b>Link time</b>	--
	<b>Post-build time</b>	X VARIANT-POST-BUILD
<b>Scope / Dependency</b>	scope: Module	

<b>SWS Item</b>	<b>PORT134_Conf :</b>	
<b>Name</b>	PortPinModeChangeable {PORT_PIN_MODE_CHANGEABLE}	
<b>Description</b>	Parameter to indicate if the mode is changeable on a port pin during runtime. True: Port Pin mode changeable allowed. False: Port Pin mode changeable not permitted.	
<b>Multiplicity</b>	1	
<b>Type</b>	EcucBooleanParamDef	
<b>Default value</b>	--	
<b>ConfigurationClass</b>	<b>Pre-compile time</b>	X VARIANT-PRE-COMPILE
	<b>Link time</b>	--
	<b>Post-build time</b>	X VARIANT-POST-BUILD
<b>Scope / Dependency</b>	scope: Module	

**No Included Containers**

### 10.2.6 PortConfigSet

<b>SWS Item</b>	<b>PORT121_Conf :</b>	
<b>Container Name</b>	PortConfigSet [Multi Config Container]	
<b>Description</b>	This container is the base of a multiple configuration set	
<b>Configuration Parameters</b>		

<b>Included Containers</b>		
<b>Container Name</b>	<b>Multiplicity</b>	<b>Scope / Dependency</b>

PortContainer	1..*	Container collecting the PortPins.
---------------	------	------------------------------------

### 10.3 Published Information

[PORT001\_PI] The standardized common published parameters as required by BSW00402 in the General Requirements on Basic Software Modules [3] shall be published within the header file of this module and need to be provided in the BSW Module Description. The according module abbreviation can be found in the List of Basic Software Modules [1].

Additional module-specific published parameters are listed below if applicable.

## 11 Changes to Release 3.0

### 11.1 Deleted SWS Items

<i>SWS Item</i>	<i>Rationale</i>
Port031	Redundant, it's already covered by Port051

### 11.2 Replaced SWS Items

<i>SWS Item</i>	<i>replaced by SWS Item</i>	<i>Rationale</i>
Port006	Port006,Port207	Made atomic
Port076	Port076,Port208	//
Port078	Port078, Port213	//
Port100	Port100,Port211	//
Port113	Port113, Port214, Port215, Port217, Port218	//
Port114	Port114, Port210	//
Port124	Port124, Port212	//

### 11.3 Changed SWS Items

<i>SWS Item</i>	<i>Rationale</i>
Port004	Made SWS item atomic
Port082	Rephrased
Port086	//
Port108	Made SWS Item atomic
Port114	Rephrased
Port130	CTPSEC issues
Port131	//
Port132	//
Port133	Made SWS Item atomic
Port147	Rephrased
Port148	Rephrased
Port038	//
Port124_Conf, Port127_Conf	Min and Max values in the Range field changed.

### 11.4 Added SWS Items

<i>SWS Item</i>	<i>Rationale</i>
Port200	Debugging Concept
Port201	//
Port202	//
Port203	//
Port204	Inclusion files modification - CTSPEC issues
Port205	//
Port219	Data Types changes - CTSPEC issues
Port220	//
Port221	//

Port222	ID added in the published information – CTSPEC issues
Port223, Port134_Conf	Addition of a new parameter to enable/disable pin mode changing at run time
Port225	Port_GetVersionInfo parameter checking.
PORT001_PI	Rework of Published Information



## 12 Changes to Release 4.0 Rev 1

### 12.1 Deleted SWS Items

<i>SWS Item</i>	<i>Rationale</i>
Port210	Due to a change to the General Requirement BSW004. (Autosar does not specify any version check for the internal files but this is completely left to the implementer)
Port132	Removed Reference to Port_Irq.c (Bugzilla

### 12.2 Replaced SWS Items

<i>SWS Item</i>	<i>replaced by SWS Item</i>	<i>Rationale</i>
Port222	Port001 PI	Rework of the published information by the AUTOSAR Administration

### 12.3 Changed SWS Items

<i>SWS Item</i>	<i>Rationale</i>
Port075	Made Requirement more clear and ready to be tested.

### 12.4 Added SWS Items

<i>SWS Item</i>	<i>Rationale</i>

