

Document Title	Specification of Module EEPROM Abstraction
Document Owner	AUTOSAR GbR
Document Responsibility	AUTOSAR GbR
Document Identification No	287
Document Classification	Standard

Document Version	1.2.1
Document Status	Final
Part of Release	3.1
Revision	0001

Document Change History			
Date	Version	Changed by	Change Description
23.06.2008	1.2.1	AUTOSAR Administration	Legal disclaimer revised
10.12.2007	1.2.0	AUTOSAR Administration	<ul style="list-style-type: none"> • EA_MAXIMUM_BLOCKING_TIME as published parameter • Small reformulations resulting from table generation • Tables in chapters 8 and 10 generated from UML model • Document meta information extended • Small layout adaptations made
14.02.2007	1.1.0	AUTOSAR Administration	<ul style="list-style-type: none"> • File include structure updated • API of initialization function adapted • Range of EA block numbers adapted • Legal disclaimer revised • Release Notes added • "Advice for users" revised • "Revision Information" added
23.03.2006	1.0.0	AUTOSAR Administration	Initial release

Page left intentionally blank

Disclaimer

This document of a specification as released by the AUTOSAR Development Partnership is intended **for the purpose of information only**. The commercial exploitation of material contained in this specification requires membership of the AUTOSAR Development Partnership or an agreement with the AUTOSAR Development Partnership. The AUTOSAR Development Partnership will not be liable for any use of this specification. Following the completion of the development of the AUTOSAR specifications commercial exploitation licenses will be made available to end users by way of written License Agreement only.

No part of this publication may be reproduced or utilized in any form or by any means, electronic or mechanical, including photocopying and microfilm, without permission in writing from the publisher." The word AUTOSAR and the AUTOSAR logo are registered trademarks.

Copyright © 2004-2008 AUTOSAR Development Partnership. All rights reserved.

Advice to users of AUTOSAR Specification Documents:

AUTOSAR Specification Documents may contain exemplary items (exemplary reference models, "use cases", and/or references to exemplary technical solutions, devices, processes or software).

Any such exemplary items are contained in the Specification Documents for illustration purposes only, and they themselves are not part of the AUTOSAR Standard. Neither their presence in such Specification Documents, nor any later documentation of AUTOSAR conformance of products actually implementing such exemplary items, imply that intellectual property rights covering such exemplary items are licensed under the same rules as applicable to the AUTOSAR Standard.

Table of Content

1	Introduction and functional overview	6
2	Acronyms and abbreviations	7
3	Related documentation.....	8
3.1	Input documents.....	8
3.2	Related standards and norms	8
4	Constraints and assumptions	10
4.1	Limitations.....	10
4.2	Applicability to car domains.....	10
5	Dependencies to other modules.....	11
5.1	File structure	11
5.1.1	Code file structure	11
5.1.2	Header file structure.....	12
6	Requirements traceability	13
7	Functional specification	20
7.1	General behavior.....	20
7.1.1	Addressing scheme and segmentation	20
7.1.2	Address calculation	21
7.1.3	Limitation of erase / write cycles	23
7.1.4	Handling of “immediate” data	23
7.1.5	Managing block consistency information.....	24
7.2	Error classification	24
7.3	Error detection.....	25
7.4	Error notification	25
7.5	Consistency checks.....	25
8	API specification.....	26
8.1	Imported Types	26
8.2	Type definitions	26
8.3	Function definitions	26
8.3.1	Ea_Init.....	26
8.3.2	Ea_SetMode	27
8.3.3	Ea_Read	27
8.3.4	Ea_Write	28
8.3.5	Ea_Cancel.....	29
8.3.6	Ea_GetStatus.....	30
8.3.7	Ea_GetJobResult	31
8.3.8	Ea_InvalidateBlock.....	31
8.3.9	Ea_GetVersionInfo.....	32
8.3.10	Ea_EraseImmediateBlock.....	33
8.4	Call-back notifications	33
8.4.1	Nvm_JobEndNotification	34
8.4.2	Nvm_JobErrorNotification	35
8.5	Scheduled functions	35

8.5.1	Ea_MainFunction	35
8.6	Expected Interfaces.....	36
8.6.1	Mandatory Interfaces	36
8.6.2	Optional Interfaces	36
8.6.3	Configurable interfaces	37
9	Sequence diagrams	39
9.1	Ea_Init	39
9.2	Ea_SetMode	40
9.3	Ea_Write	41
9.4	Ea_Cancel.....	42
10	Configuration specification	43
10.1	How to read this chapter	43
10.1.1	Configuration and configuration parameters	43
10.1.2	Containers.....	43
10.1.3	Specification template for configuration parameters	43
10.2	Containers and configuration parameters	44
10.2.1	Variants.....	44
10.2.2	Ea.....	45
10.2.3	EaBlockConfiguration.....	45
10.3	Published Information.....	46
10.3.1	EaPublishedInformation	47
11	Changes during SWS Improvements by Technical Office	49
11.1	Deleted SWS Items	49
11.2	Replaced SWS Items	49
11.3	Changed SWS Items.....	49
11.4	Added SWS Items	50

1 Introduction and functional overview

This specification describes the functionality, API and configuration of the EEPROM Abstraction Layer (see Figure 1).

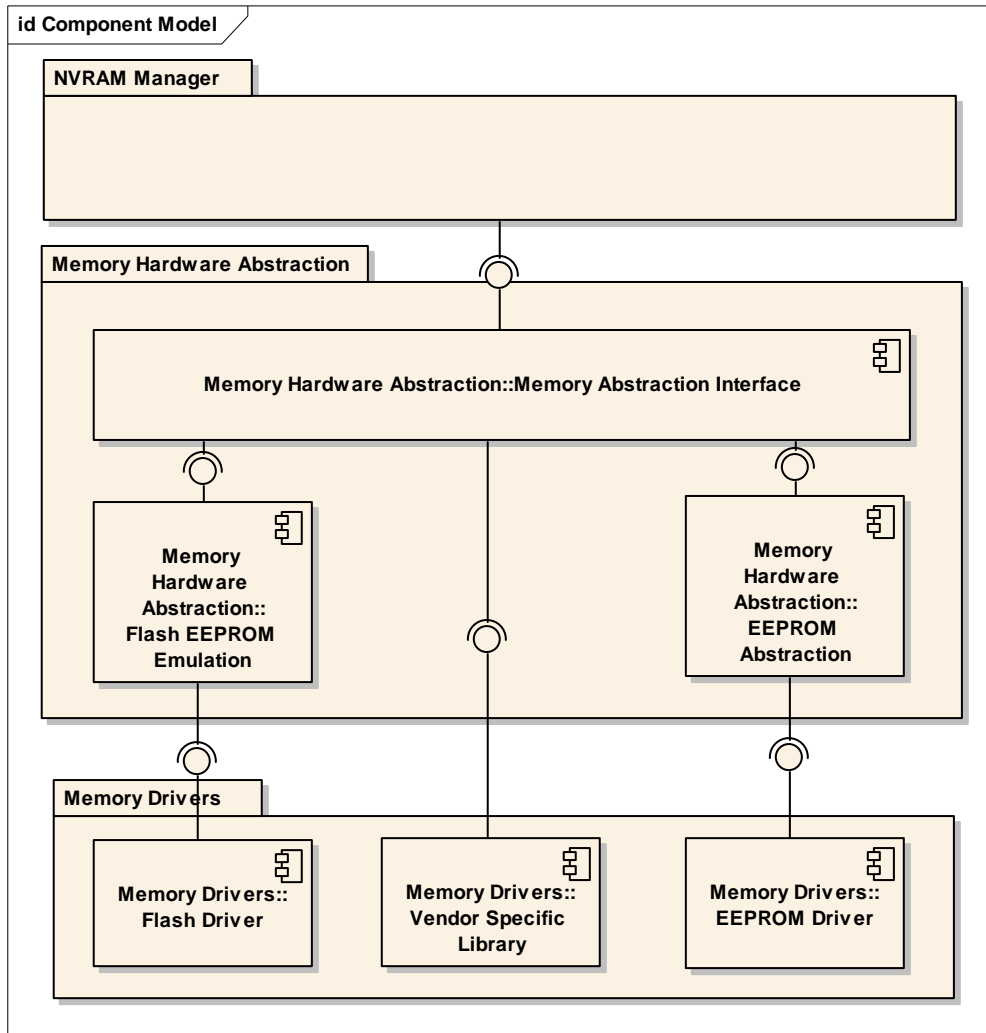

Figure 1: Module overview of memory hardware abstraction layer

The EEPROM Abstraction (EA) abstracts from the device specific addressing scheme and segmentation and provides the upper layers with a virtual addressing scheme and segmentation as well as a “virtually” unlimited number of erase cycles.

2 Acronyms and abbreviations

Acronyms and abbreviations which have a local scope and therefore are not contained in the AUTOSAR glossary must appear in a local glossary.

Abbreviation / Acronym:	Description:
EA	EEPROM Abstraction
EEPROM	Electrically Erasable and Programmable ROM (Read Only Memory)
FEE	Flash EEPROM Emulation
LSB	Least significant bit / byte (depending on context). Here it's bit.
MemIf	Memory Abstraction Interface
MSB	Most significant bit / byte (depending on context). Here it's bit.
NvM	NVRAM Manager
NVRAM	Non-volatile RAM (Random Access Memory)
NVRAM block	Management unit as seen by the NVRAM Manager
(Logical) block	Smallest writable / erasable unit as seen by the modules user. Consists of one or more virtual pages.
Virtual page	May consist of one or several physical pages to ease handling of logical blocks and address calculation.
Internal residue	Unused space at the end of the last virtual page if the configured block size isn't an integer multiple of the virtual page size (see Figure 3).
Virtual address	Consisting of 16 bit block number and 16 bit offset inside the logical block.
Physical address	Address information in device specific format (depending on the underlying EEPROM driver and device) that is used to access a logical block.
Dataset	Concept of the NVRAM manager: A user addressable array of blocks of the same size. E.g. could be used to provide different configuration settings for the CAN driver (CAN IDs, filter settings, ...) to an ECU which has otherwise identical application software (e.g. door module).
Redundant copy	Concept of the NVRAM manager: Storing the same information twice to enhance reliability of data storage.

3 Related documentation

3.1 Input documents

[1] List of Basic Software Modules

https://svn2.autosar.org/repos2/22_Releases

AUTOSAR_BasicSoftwareModules.pdf

[2] Layered Software Architecture

https://svn2.autosar.org/repos2/22_Releases

AUTOSAR_LayeredSoftwareArchitecture.pdf

[3] General Requirements on Basic Software Modules

https://svn2.autosar.org/repos2/22_Releases

AUTOSAR_SRS_General.pdf

[4] General Requirements on SPAL

https://svn2.autosar.org/repos2/22_Releases

AUTOSAR_SRS_SPAL_General.pdf

[5] Requirements on Memory Hardware Abstraction Layer

https://svn2.autosar.org/repos2/22_Releases

AUTOSAR_SRS_MemHW_AbstractionLayer.doc

[6] Specification of Development Error Tracer

https://svn2.autosar.org/repos2/22_Releases

AUTOSAR_SWS_DET.pdf

[7] Specification of ECU Configuration,

https://svn2.autosar.org/repos2/22_Releases

AUTOSAR_ECU_Configuration.pdf

[8] AUTOSAR Basic Software Module Description Template,

https://svn2.autosar.org/repos2/22_Releases

AUTOSAR_BSW_Module_Description.pdf

3.2 Related standards and norms

[7] Specification of NVRAM Manager

https://svn2.autosar.org/repos2/22_Releases

AUTOSAR_SWS_NVRAM_Manager.doc

[8] Specification of Memory Abstraction Interface

https://svn2.autosar.org/repos2/22_Releases

AUTOSAR_SWS_Mem_AbstractionInterface.pdf

[9] Specification of Flash EEPROM Emulation

https://svn2.autosar.org/repos2/22_Releases

AUTOSAR_SWS_Flash_EEPROM_Emulation.pdf

4 Constraints and assumptions

4.1 Limitations

No limitations.

4.2 Applicability to car domains

No restrictions.

5 Dependencies to other modules

This module depends on the capabilities of the underlying EEPROM driver as well as the configuration of the NVRAM manager.

5.1 File structure

5.1.1 Code file structure

EA057: The code file structure shall not be defined within this specification.

5.1.2 Header file structure

EA113: The Ea module shall comply with the following file include structure:

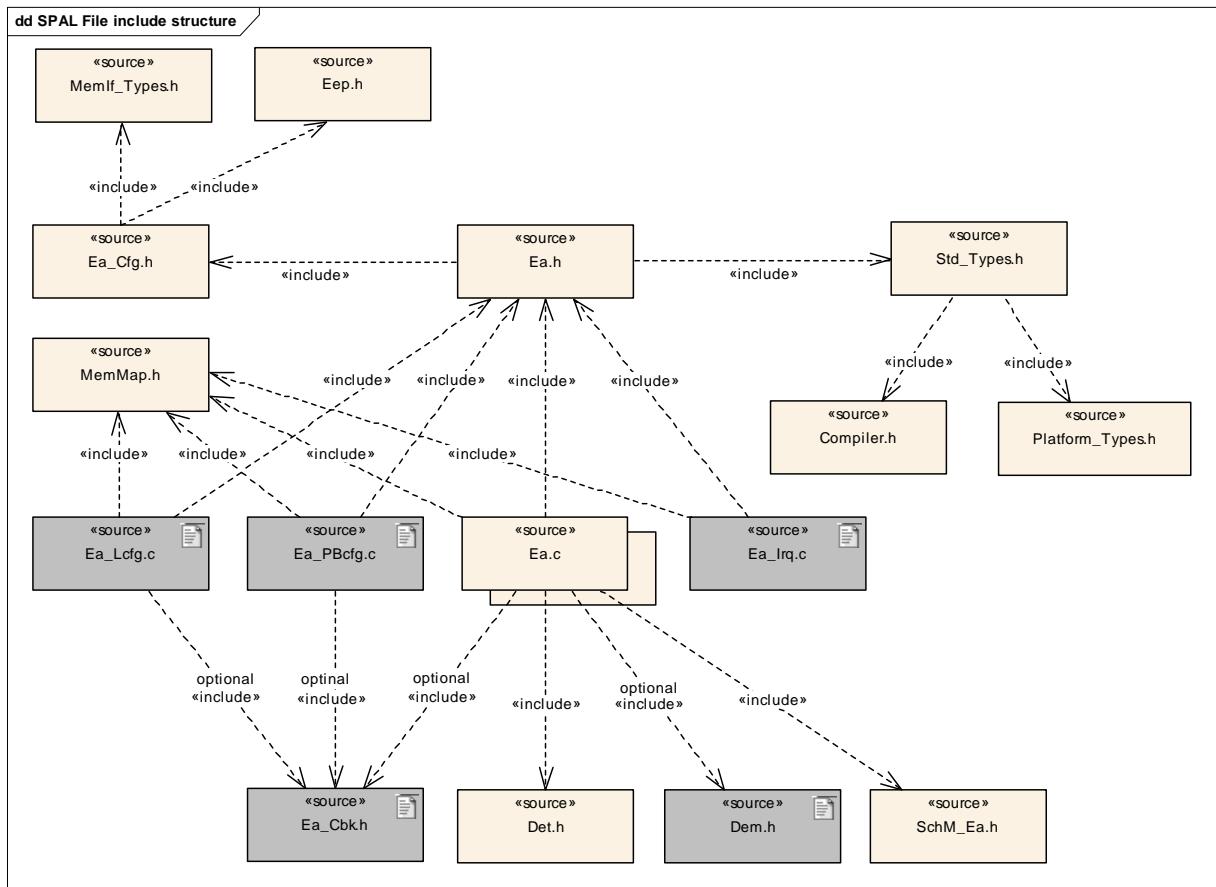

Figure 2: EEPROM Abstraction Layer File Include Structure

- Ea.h shall include Eep.h
- Ea.h shall include StdTypes.h and Ea_Cfg.h
- Ea_Cfg.h shall include MemIf_Types.h
- Ea_Lcfg.c shall include Ea_Cfg.h
- Ea.c shall include Ea.h, MemMap.h and other standard header files (if needed by the implementation).
- Ea.c shall include Ea_Cbk.h

EA112: The upper layer modules shall only include Ea.h

EA058: The EA module shall include the Dem.h file. By this inclusion the APIs to report errors as well as the required Event Id symbols are included. This specification defines the name of the Event Id symbols which are provided by XML to the DEM configuration tool. The DEM configuration tool assigns ECU dependent values to the Event Id symbols and publishes the symbols in Dem_IntErrId.h.

6 Requirements traceability

Document: General Requirements on Basic Software Modules

Requirement	Satisfied by
[BSW00344] Reference to link-time configuration	Not applicable (this module does not provide any post-build parameters)
[BSW00404] Reference to post build time configuration	Not applicable (this module does not provide post build time configuration)
[BSW00405] Reference to multiple configuration sets	Not applicable (this module does not support multiple configuration sets)
[BSW00345] Pre-compile-time configuration	EA039, EA040
[BSW159] Tool-based configuration	EA039, EA040
[BSW167] Static configuration checking	EA041
[BSW171] Configurability of optional functionality	Not applicable (no optional functionality)
[BSW170] Data for reconfiguration of AUTOSAR SW-Components	Not applicable (no reconfiguration supported)
[BSW00380] Separate C-File for configuration parameters	Not applicable (no link-time or post build time configuration parameters)
[BSW00381] Separate configuration header file for pre-compile time parameters	EA002
[BSW00412] Separate H-File for configuration parameters [approved]	Not applicable (no link-time or post build time configuration parameters)
[BSW00383] List dependencies of configuration files	EA002
[BSW00384] List dependencies to other modules	Chapter 5
[BSW00387] Specify the configuration class of callback function	Chapter 8.6
[BSW00388] Introduce containers	Chapter 10.2
[BSW00389] Containers shall have names	Chapter 10.2
[BSW00390] Parameter content shall be unique within the module	Chapter 8, Chapter 10.2.3, Chapter 10.2.4
[BSW00391] Parameter shall have unique names	Chapter 8, Chapter 10.2.3, Chapter 10.2.4
[BSW00392] Parameters shall have a type	Chapter 8, Chapter 10.2.3, Chapter 10.2.4
[BSW00393] Parameters shall have a range	Chapter 8, Chapter 10.2.3, Chapter 10.2.4
[BSW00394] Specify the scope of the parameters	Chapter 8, Chapter 10.2.3, Chapter 10.2.4
[BSW00395] List the required parameters (per parameter)	Chapter 8, Chapter 10.2.3, Chapter 10.2.4
[BSW00396] Configuration classes	Chapter 8, Chapter 10.2.3, Chapter 10.2.4
[BSW00397] Pre-compile-time parameters	Chapter 8, Chapter 10.2.3, Chapter 10.2.4
[BSW00398] Link-time parameters	Not applicable (no link-time configuration parameters)
[BSW00399] Loadable Post-build time parameters	Not applicable (no post build time configuration parameters)
[BSW00400] Selectable Post-build time parameters	Not applicable (no post build time configuration parameters)
[BSW00402] Published information	Chapter 10.3
[BSW00375] Notification of wake-up reason	Not applicable (this module does not provide wakeup capabilities)
[BSW101] Initialization interface	EA017

[BSW00416] Sequence of Initialization	Not applicable (requirement on system design, not a single module)
[BSW00406] Check module initialization	Not applicable (there are no standard parameters that could be checked)
[BSW168] Diagnostic Interface of SW components	Not applicable (this module does not provide special diagnostics support)
[BSW00407] Function to read out published parameters	Chapter 8.3.9, EA043
[BSW00423] Usage of SW-C template to describe BSW modules with AUTOSAR Interfaces	Not applicable (this module does not provide an AUTOSAR interface)
[BSW00424] BSW main processing function task allocation	Not applicable (requirement on system design, not on a single module)
[BSW00425] Trigger conditions for schedulable objects	Not applicable (requirement on the BSW module description template)
[BSW00426] Exclusive areas in BSW modules	Not applicable (no exclusive areas defined in this module)
[BSW00427] ISR description for BSW modules	Not applicable (this module does not implement any ISRs)
[BSW00428] Execution order dependencies of main processing functions	Not applicable (only one main processing function in this module)
[BSW00429] Restricted BSW OS functionality access	Not applicable (this module does not use any OS functionality)
[BSW00431] The BSW Scheduler module implements task bodies	Not applicable (requirement on the BSW scheduler)
[BSW00432] Modules should have separate main processing functions for read/receive and write/transmit data path	Not applicable (only one main processing function in this module)
[BSW00433] Calling of main processing functions	Not applicable (requirement on system design, not on a single module)
[BSW00434] The Schedule Module shall provide an API for exclusive areas	Not applicable (requirement on the schedule module - this is not it)
[BSW00336] Shutdown interface	Not applicable (this module does not provide shutdown capabilities)
[BSW00337] Classification of errors	EA010
[BSW00338] Detection and Reporting of development errors	EA011, EA012, EA045
[BSW00369] Do not return development error codes via API	EA045
[BSW00339] Reporting of production relevant error status	EA010
[BSW00421] Reporting of production relevant error events	Not applicable (no production relevant error events, only error status)
[BSW00422] Debouncing of production relevant error status	Not applicable (requirement on the DEM, not this module)
[BSW00420] Production relevant error event rate detection	Not applicable (requirement on the DEM, not this module)
[BSW00417] Reporting of Error Events by Non-Basic Software	Not applicable (requirement on non BSW modules)
[BSW00323] API parameter checking	EA038

[BSW004] Version check	EA013
[BSW00409] Header files for production code error IDs	EA048
[BSW00385] List possible error notifications	Chapter 8.6
[BSW00386] Configuration for detecting an error	EA010, EA011, EA045
[BSW161] Microcontroller abstraction	Not applicable (requirement on AUTOSAR architecture, not a single module)
[BSW162] ECU layout abstraction	Not applicable (requirement on AUTOSAR architecture, not a single module)
[BSW00324] Do not use HIS I/O Library	Not applicable (architecture decision)
[BSW005] No hard coded horizontal interfaces within MCAL	Not applicable (requirement on AUTOSAR architecture, not a single module)
[BSW00415] User dependent include files	Not applicable (only one user for this module)
[BSW164] Implementation of interrupt service routines	Not applicable (this module does not implement any ISRs)
[BSW00325] Runtime of interrupt service routines	EA069
[BSW00326] Transition from ISRs to OS tasks	Not applicable (requirement on implementation, not on specification)
[BSW00342] Usage of source code and object code	Not applicable (requirement on AUTOSAR architecture, not a single module)
[BSW00343] Specification and configuration of time	EA070
[BSW160] Human-readable configuration data	Not applicable (requirement on documentation, not on specification)
[BSW007] HIS MISRA C	Not applicable (requirement on implementation, not on specification)
[BSW00300] Module naming convention	Not applicable (requirement on implementation, not on specification)
[BSW00413] Accessing instances of BSW modules	Requirement can not be implemented in R2.0 timeframe.
[BSW00347] Naming separation of different instances of BSW drivers	Not applicable (requirement on the implementation, not on the specification)
[BSW00305] Self-defined data types naming convention	Chapter 8.2
[BSW00307] Global variables naming convention	Not applicable (requirement on the implementation, not on the specification)
[BSW00310] API naming convention	Chapter 8.3
[BSW00373] Main processing function naming convention	Chapter 8.5.1
[BSW00327] Error values naming convention	EA010, EA012
[BSW00335] Status values naming convention	Chapter 8.1
[BSW00350] Development error detection keyword	EA011, EA059, EA039
[BSW00408] Configuration parameter naming convention	Chapter 10.2
[BSW00410] Compiler switches shall have defined values	Chapter 10.2

[BSW00411] Get version info keyword	Chapter 10.2.3
[BSW00346] Basic set of module files	EA002
[BSW158] Separation of configuration from implementation	EA002
[BSW00314] Separation of interrupt frames and service routines	Not applicable (this module does not implement any ISRs)
[BSW00370] Separation of callback interface from API	Chapter 8.4
[BSW00348] Standard type header	Not applicable (requirement on the standard header file)
[BSW00353] Platform specific type header	Not applicable (requirement on the platform specific header file)
[BSW00361] Compiler specific language extension header	Not applicable (requirement on the compiler specific header file)
[BSW00301] Limit imported information	EA002
[BSW00302] Limit exported information	Not applicable (requirement on the implementation, not on the specification)
[BSW00328] Avoid duplication of code	Not applicable (requirement on the implementation, not on the specification)
[BSW00312] Shared code shall be reentrant	Not applicable (requirement on the implementation, not on the specification)
[BSW006] Platform independency	Not applicable (this is a module of the microcontroller abstraction layer)
[BSW00357] Standard API return type	Chapter 8.3.3, Chapter 8.3.4. Chapter 8.3.8, Chapter 8.3.10
[BSW00377] Module specific API return types	Chapter 8.3.6, Chapter 0
[BSW00304] AUTOSAR integer data types	Not applicable (requirement on implementation, not for specification)
[BSW00355] Do not redefine AUTOSAR integer data types	Not applicable (requirement on implementation, not for specification)
[BSW00378] AUTOSAR boolean type	Not applicable (requirement on implementation, not for specification)
[BSW00306] Avoid direct use of compiler and platform specific keywords	Not applicable (requirement on implementation, not for specification)
[BSW00308] Definition of global data	Not applicable (requirement on implementation, not for specification)
[BSW00309] Global data with read-only constraint	Not applicable (requirement on implementation, not for specification)
[BSW00371] Do not pass function pointers via API	Not applicable (no function pointers in this specification)
[BSW00358] Return type of init() functions	Chapter 8.3.1
[BSW00414] Parameter of init function	Chapter 8.3.1
[BSW00376] Return type and parameters of main processing functions	Chapter 8.5.1
[BSW00359] Return type of callback functions	Not applicable (this module does not provide any callback routines)
[BSW00360] Parameters of callback functions	Not applicable (this module does not provide any callback routines)

[BSW00329] Avoidance of generic interfaces	Chapter 8.3 (explicit interfaces defined)
[BSW00330] Usage of macros / inline functions instead of functions	Not applicable (requirement on implementation, not for specification)
[BSW00331] Separation of error and status values	EA010, EA045
[BSW009] Module User Documentation	Not applicable (requirement on documentation, not on specification)
[BSW00401] Documentation of multiple instances of configuration parameters	Not applicable (all configuration parameters are single instance only)
[BSW172] Compatibility and documentation of scheduling strategy	Not applicable (no internal scheduling policy)
[BSW010] Memory resource documentation	Not applicable (requirement on documentation, not on specification)
[BSW00333] Documentation of callback function context	Not applicable (requirement on documentation, not for specification)
[BSW00374] Module vendor identification	EA043
[BSW00379] Module identification	EA043
[BSW003] Version identification	EA043
[BSW00318] Format of module version numbers	EA043
[BSW00321] Enumeration of module version numbers	Not applicable (requirement on implementation, not for specification)
[BSW00341] Microcontroller compatibility documentation	Not applicable (requirement on documentation, not on specification)
[BSW00334] Provision of XML file	Not applicable (requirement on documentation, not on specification)

Document: General Requirements on SPAL

Requirement	Satisfied by
[BSW12263] Object code compatible configuration concept	Not applicable (this module does not provide any post-build parameters)
[BSW12056] Configuration of notification mechanisms	Not applicable (this module does not provide any notification mechanisms)
[BSW12267] Configuration of wake-up sources	Not applicable (this module does not provide any wakeup capabilities)
[BSW12057] Driver module initialization	EA017
[BSW12125] Initialization of hardware resources	Not applicable (this module has no direct hardware access)
[BSW12163] Driver module de-initialization	Not applicable (this module does not provide any shutdown capabilities)
[BSW12058] Individual initialization of overall registers	Not applicable (this module has no direct hardware access)
[BSW12059] General initialization of overall registers	Not applicable (this module has no direct hardware access)
[BSW12060] Responsibility for initialization of one-time writable registers	Not applicable (this module has no direct hardware access)

[BSW12461] Responsibility for register initialization [approved]	Not applicable (this module has no direct hardware access)
[BSW12462] Provide settings for register initialization [approved]	Not applicable (this module has no direct hardware access)
[BSW12463] Combine and forward settings for register initialization	Not applicable (this module has no direct hardware access)
[BSW12062] Selection of static configuration sets	Not applicable (this module does not have configuration data)
[BSW12068] MCAL initialization sequence	Not applicable (this module belongs to the ECU abstraction layer)
[BSW12069] Wake-up notification of ECU State Manager	Not applicable (this module does not provide any wakeup capabilities)
[BSW157] Notification mechanisms of drivers and handlers	Not applicable (this module does not provide any notification mechanisms)
[BSW12155] Prototypes of callback functions	Not applicable (this module does not implement any callback routines)
[BSW12169] Control of operation mode	EA020
[BSW12063] Raw value mode	Not applicable (this module does not handle or mishandle any data)
[BSW12075] Use of application buffers	Chapters 8.3.3, and 8.3.4
[BSW12129] Resetting of interrupt flags	Not applicable (this module does not implement any ISRs)
[BSW12064] Change of operation mode during running operation	Not applicable (this module has no internal operation mode)
[BSW12448] Behavior after development error detection	Chapter 7.4
[BSW12067] Setting of wake-up conditions	Not applicable (this module does not provide any wakeup capabilities)
[BSW12077] Non-blocking implementation	Not applicable (this module does not implement any schedulable services)
[BSW12078] Runtime and memory efficiency	Not applicable (requirement on implementation, not on specification)
[BSW12092] Access to drivers	Not applicable (this module is the EEPROM driver's "manager")
[BSW12265] Configuration data shall be kept constant	Not applicable (this module does not have configuration data)
[BSW12264] Specification of configuration items	EA039, EA040, EA043
[BSW12081] Use HIS requirements as input	Not applicable (no corresponding HIS requirements available)

Document: Requirements on Memory Hardware Abstraction Layer

Requirement	Satisfied by
BSW14001 Configuration of address alignment	EA004, EA039
BSW14002 Configuration of number of required write cycles	EA079, EA080, EA040
BSW14003 Configuration of maximum blocking time	EA039
BSW14004 Configuration of "immediate" data blocks	EA040

BSW14026 Don't use certain block numbers	EA006
BSW14027 Publish overhead for internal management data per block	EA043
BSW14005 Virtual linear address space and segmentation	EA003
BSW14006 Alignment of block erase / write addresses	EA004, EA024 EA027
BSW14007 Alignment of block read addresses	EA021
BSW14008 Checking block read addresses	EA038
BSW14009 Conversion of logical to physical addresses	EA007
BSW14010 Block-wise write service	Chapter 8.3.4
BSW14029 Block-wise read service	Chapter 8.3.3
BSW14031 Service to cancel an ongoing asynchronous operation	Chapter 8.3.5
BSW14028 Service to invalidate a memory block	Chapter 8.3.8
BSW14012 Spreading of write access	EA079, EA080
BSW14013 Writing of "immediate" data must not be delayed	EA009
BSW14032 Block-wise erase service for immediate data	EA063, EA064, EA065
BSW14014 Detection of data inconsistencies	EA104, EA105, EA046, EA047
BSW14015 Reporting of data inconsistencies	EA104, EA105,
BSW14016 Don't return inconsistent data to the caller	EA104, EA105,
BSW14017 Scope of EEPROM Abstraction Layer	Chapter EA0011
BSW14018 Scope of Flash EEPROM Emulation	Not applicable (this is the EA modules specification)

7 Functional specification

7.1 General behavior

7.1.1 Addressing scheme and segmentation

The EEPROM Abstraction (EA) provides upper layers with a 32bit virtual linear address space and uniform segmentation scheme. This virtual 32bit addresses consists of

- a 16bit block number – allowing a (theoretical) number of 65536 logical blocks
- a 16bit block offset – allowing a (theoretical) block size of 64KByte per block

The 16bit block number represents a configurable (virtual) paging mechanism. The values for this address alignment can be derived from that of the underlying EEPROM driver and device. This virtual paging is configurable via the parameter `EA_VIRTUAL_PAGE_SIZE`.

EA075: The configuration of the Ea module shall be such that the virtual page size (defined in `EA_VIRTUAL_PAGE_SIZE`) is an integer multiple of the physical page size, i.e. it is not allowed to configure a smaller virtual page than the actual physical page size.

Example:

The size of a virtual page is configured to be eight bytes, thus the address alignment is eight bytes. The logical block with block number 1 is placed at physical address x. The logical block with the block number 2 then would be placed at x+8, block number 3 would be placed at x+16.

Note: This specification requirement allows the physical start address of a logical block to be calculated rather than making a lookup table necessary for the address mapping.

EA005: Each configured logical block shall take up an integer multiple of the configured virtual page size (see also Chapter 10.2.3, configuration parameter `EA_VIRTUAL_PAGE_SIZE`).

EA068: Logical blocks must not overlap each other and must not be contained within one another.

Example:

The address alignment / virtual paging is configured to be eight bytes by setting the parameter `EA_VIRTUAL_PAGE_SIZE` accordingly. The logical block number 1 is configured to have a size of 32 bytes (see Figure 3). This logical block would use exactly 4 virtual pages. The next logical block thus would get the block number 5, since block numbers 2, 3 and 4 are “blocked” by the first logical block. This second block is configured to have a size of 100 bytes, taking up 13 virtual pages and leaving 4 bytes of the last page unused. The next available logical block number thus would be 17.

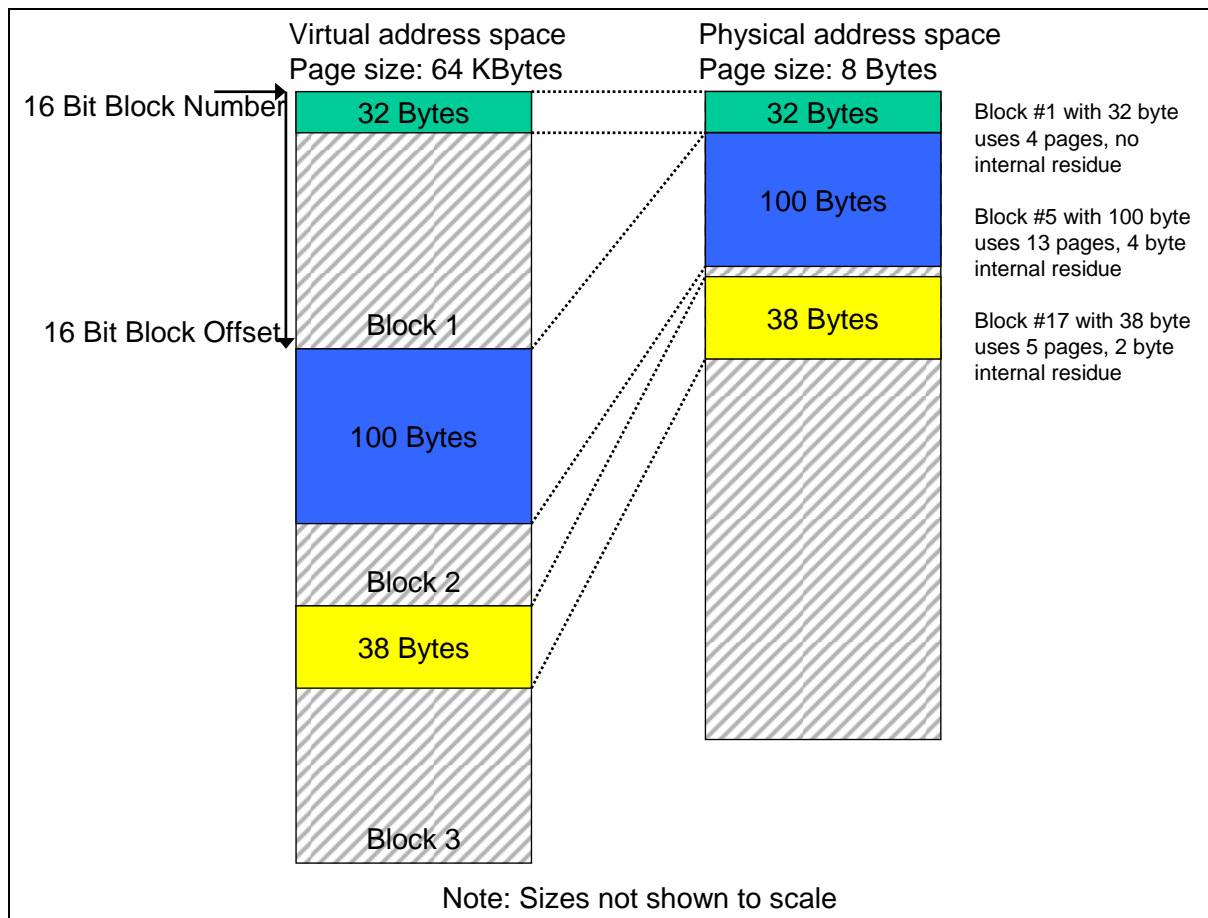

Figure 3: Virtual vs. physical memory layout

EA006: The block numbers 0x0000 and 0xFFFF shall not be configurable for a logical block (see chapter 10.2.3, `EaBlockNumber` for details).

7.1.2 Address calculation

EA007: Depending on the implementation of the EA module and the exact address format used, the functions of the EA module shall combine the 16bit block number and 16bit block offset to derive the physical EEPROM address needed for the underlying EEPROM driver.

Note: The exact address format needed by the underlying EEPROM driver and therefore the mechanism how to derive the physical EEPROM address from the given 16bit block number and 16bit block offset depends on the EEPROM device and the implementation of this module and can therefore not be specified in this document.

EA066: Only those bits of the 16bit block number, that do not denote a specific dataset or redundant copy shall be used for address calculation.

Note: Since this information is needed by the NVRAM manager, the number of bits to encode this can be configured for the NVRAM manager with the parameter `NVM_DATASET_SELECTION_BITS`.

Example: Dataset information is configured to be encoded in the four LSB's of the 16bit block number (allowing for a maximum of 16 datasets per NVRAM block and a total of 4094 NVRAM blocks). An implementer decides to store all datasets of a logical block directly adjacent and using the length of the block and a pointer to access each dataset. To calculate the start address of the block (the address of the first dataset) she/he uses only the 12 MSB's, to access a specific dataset she/he adds the size of the block multiplied by the dataset index (the four MSB's) to this start address (Figure 4).

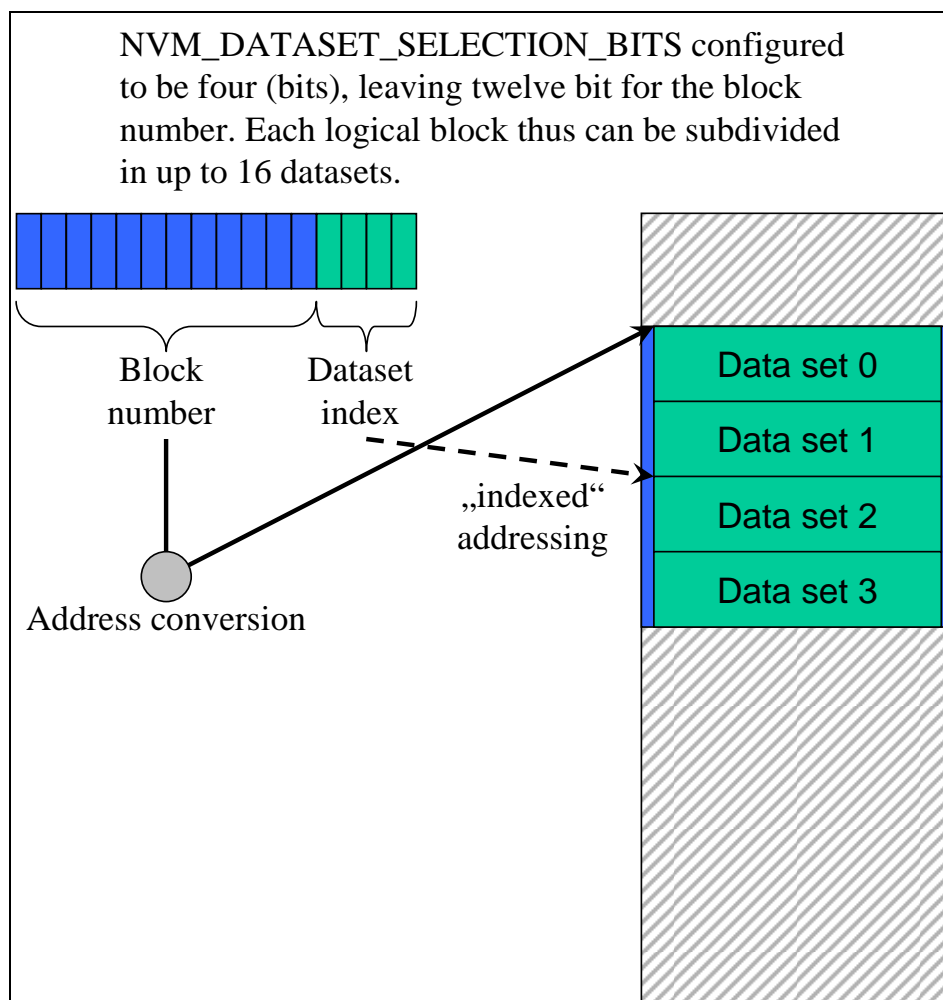

Figure 4: Block number and dataset index

7.1.3 Limitation of erase / write cycles

EA079: The configuration of the Ea module shall define the expected number of erase/write cycles for each logical block in the configuration parameter `EaNumberOfWriteCycles`.

EA080: If the underlying EEPROM device or device driver does not provide at least the configured number of erase/write cycles per physical memory cell, the Ea module shall provide mechanisms to spread the erase/ write access such that the physical device is not overstressed. This shall also apply to all management data used internally by the EA module.

Example:

The logical block number 1 is configured for an expected 500.000 write cycles, the underlying EEPROM device and device driver are only specified for 100.000 erase cycles. In this case the EA module has to provide (at least) five separate memory areas and alternate the access between those areas internally, so that each physical memory location is only erased for a maximum of the specified 100.000 cycles.

7.1.4 Handling of “immediate” data

EA009: Blocks, containing immediate data, have to be written instantaneously, i.e. the EA module has to ensure that it can write such blocks without the need to erase the corresponding memory area (e.g. by using pre-erased memory) and that the write request is not delayed by currently running module internal management operations.

Note: An ongoing lower priority read / erase / write or compare job shall be cancelled by the NVRAM manager before immediate data is written. This module only has to ensure that this write than can be performed immediately.

Note: A running operation on the hardware (e.g. writing one page or erasing one sector) can usually not be aborted once it has been started. The maximum time of the longest hardware operation thus has to be accepted as delay even for immediate data.

Example: Three blocks with 10 bytes each have been configured for immediate data. The EA module / configuration tool reserves these 30 bytes (plus the implementation specific overhead per block / page if needed) for use by this immediate data only. That is this memory area shall not be used for storage of other data blocks.

Now, the NVRAM manager has requested the EA module to write a data block of 100 bytes. While this block is being written a situation occurs that one (or several) of the immediate data blocks need to be written. Therefore the NVRAM manager cancels the ongoing write request and subsequently issues the write request for the (first) block containing immediate data. The cancellation of the ongoing write request is performed synchronously by the EA module and the underlying EEPROM driver that is the write request for the immediate data can be started without any further delay. However, before the first bytes of immediate data can be written however, the EA module respectively the underlying driver have to wait for the end of an ongoing

hardware access from the previous write request (e.g. writing of a page, erasing of a sector, transfer via SPI, ...).

7.1.5 Managing block consistency information

EA046: The Ea module shall manage for each block the information, whether this block is “correct” from the point of view of the EA module or not. This consistency information shall only concern the internal handling of the block, not the block’s contents.

EA047: When a block write operation is started the Ea module shall mark the corresponding block as inconsistent¹. Upon the successful end of the block write operation, the Ea module shall mark the block as consistent (again).

Note: This internal management information should not be mixed up with the validity information of a block which can be manipulated by using the Ea_InvalidateBlock service, i.e. the EA shall be able to distinguish between an inconsistent block and a block that has been deliberately invalidated by the upper layer.

7.2 Error classification

EA048: Values for production code Event Ids are assigned externally by the configuration of the Dem. They are published in the file Dem_IntErrId.h and included via Dem.h.

EA049: Development error values are of type uint8.

EA010: The Ea module shall detect the following errors and exceptions depending on its configuration (development/production):

Type or error	Relevance	Related error code	Value [hex]
API service called with invalid block number	Development	EA_E_INVALID_BLOCK_NO	0x02

¹ This does not necessarily mean a write operation on the physical device. If there are other means to detect the consistency of a logical block, changing the management information stored with the block shall be avoided.

7.3 Error detection

EA011: The detection of development errors shall be configurable (on/off) at pre-compile time. The switch `EA_DEV_ERROR_DETECT` shall activate or deactivate the detection of all development errors.

EA059: If the `EA_DEV_ERROR_DETECT` switch is enabled, API parameter checking is enabled. The detailed description of the detected errors can be found in chapter 7.2 and chapter 8.

EA060: The detection of production code errors cannot be switched off.

EA012: Additional errors that are detected because of specific implementation and/or specific hardware properties shall be added in the module's implementation documentation. The classification and enumeration shall be compatible with the errors listed above.

7.4 Error notification

EA045: Detected development errors shall be reported to the `Det_ReportError` service of the Development Error Tracer (DET) if the pre-processor switch `PWM_DEV_ERROR_DETECT` is set (see chapter 10).

EA081: Production errors shall be reported to Diagnostic Event Manager.

7.5 Consistency checks

EA013: The EA module's implementation shall check its version numbers against the version information given in the modules header files to ensure compatibility between implementation and configuration of the module.

EA038: The EA module shall not implement any kind of parameter checks during runtime. Instead the parameter check of the underlying driver shall be enabled if needed.

Note: The configuration tool shall check all configuration parameters for being within the expected bounds. Also the dependencies between configuration parameters shall be checked by the configuration tool during system generation or during the build process (for details see chapter 10).

8 API specification

8.1 Imported Types

EA116: The EA module shall import the types mentioned in [EA083](#) from the header files `Eep.h`, `Std_Types.h` respectively `MemIf_Types.h`.

EA117: The types mentioned in [EA083](#) shall not be changed or extended for a specific EA module or hardware platform.

EA083:

<i>Header file</i>	<i>Imported Type</i>
Eep_Types.h	Eep_LengthType
	Eep_AddressType
MemIf_Types.h	MemIf_JobResultType
	MemIf_StatusType
	MemIf_ModeType
Std_Types.h	Std_ReturnType
	Std_VersionInfoType

8.2 Type definitions

This module does not define any module specific types.

8.3 Function definitions

8.3.1 Ea_Init

EA084:

Service name:	Ea_Init
Syntax:	void Ea_Init()
Service ID[hex]:	0x00
Sync/Async:	Synchronous
Reentrancy:	Non Reentrant
Parameters (in):	None
Parameters (inout):	None
Parameters (out):	None
Return value:	None
Description:	Initializes the EEPROM abstraction module.

EA017: The function `Ea_Init` shall initialize the EEPROM abstraction module.

EA076: The Ea module's environment shall not call the function Ea_Init during a running operation of the EA module.

8.3.2 Ea_SetMode

EA085:

Service name:	Ea_SetMode
Syntax:	void Ea_SetMode(MemIf_ModeType Mode)
Service ID[hex]:	0x01
Sync/Async:	Synchronous
Reentrancy:	Non Reentrant
Parameters (in):	Mode Desired mode for the underlying EEPROM driver
Parameters (inout):	None
Parameters (out):	None
Return value:	None
Description:	Sets the mode.

EA020: If supported by the underlying hardware and device driver, the function Ea_SetMode shall call the "Eep_SetMode" function of the EEPROM driver with the given "Mode" parameter.

8.3.3 Ea_Read

EA086:

Service name:	Ea_Read
Syntax:	Std_ReturnType Ea_Read(uint16 BlockNumber, uint16 BlockOffset, uint8* DataBufferPtr, uint16 Length)
Service ID[hex]:	0x02
Sync/Async:	Asynchronous
Reentrancy:	Non Reentrant
Parameters (in):	BlockNumber Number of logical block, also denoting start address of that block in EEPROM. BlockOffset Read address offset inside the block Length Number of bytes to read
Parameters (inout):	None
Parameters (out):	DataBufferPtr Pointer to data buffer
Return value:	Std_ReturnType E_OK - The read job was accepted by the underlying memory driver. E_NOT_OK - The read job has not been accepted by the underlying memory driver.
Description:	Reads Length bytes of block Blocknumber at offset BlockOffset into the buffer DataBufferPtr.

EA021: The function `Ea_Read` shall take the block number and offset and calculate the corresponding memory read address.

Note: The address offset and length parameter can take any value within the given types range, this allows reading of an arbitrary number of bytes from an arbitrary address inside a logical block.

EA115: The function `Ea_Read` shall check whether the requested block has been invalidated (see `Ea_InvalidateBlock`) by the application. In this case it shall set the job result to `MEMIF_BLOCK_INVALID` and return the value `E_NOT_OK` to the caller without reading the blocks contents.

EA022: The function `Ea_Read` shall call the read function of the underlying EEPROM driver with the calculated read address, the length and data buffer parameters provided by the caller.

EA072: The function `Ea_Read` shall pass the return value of the drivers read function back to the caller.

8.3.4 Ea_Write

EA087:

Service name:	Ea_Write	
Syntax:	<pre>Std_ReturnType Ea_Write(uint16 BlockNumber, uint8* DataBufferPtr)</pre>	
Service ID[hex]:	0x03	
Sync/Async:	Asynchronous	
Reentrancy:	Non Reentrant	
Parameters (in):	BlockNumber	Number of logical block, also denoting start address of that block in EEPROM.
	DataBufferPtr	Pointer to data buffer
Parameters (inout):	None	
Parameters (out):	None	
Return value:	Std_ReturnType	E_OK - The write job was accepted by the underlying memory driver. E_NOT_OK - The write job has not been accepted by the underlying memory driver.
Description:	Writes the contents of the DataBufferPtr to the block BlockNumber.	

EA024: The function `Ea_Write` shall take the block number and calculate the corresponding memory write address. The block offset shall be fixed to zero.

EA025: The function `Ea_Write` shall copy the given / computed parameters to module internal variables, initiate a write job, set the FEE module status to `MEMIF_BUSY`, set the job result to `MEMIF_JOB_PENDING` and return with `E_OK`.

EA026: The EA module shall execute the write job of the function `Ea_Write` asynchronously within the EA module's main function.

8.3.5 Ea_Cancel

EA088:

Service name:	Ea_Cancel
Syntax:	void Ea_Cancel()
Service ID[hex]:	0x04
Sync/Async:	Asynchronous
Reentrancy:	Non Reentrant
Parameters (in):	None
Parameters (inout):	None
Parameters (out):	None
Return value:	None
Description:	Cancels the ongoing asynchronous operation.

Sync/Async → see note below (this text should be deleted by the reviewer, please)

EA077: The function `Ea_Cancel` shall call the cancel function of the underlying EEPROM driver.

EA078: The function `Ea_Cancel` shall reset the Ea module's internal variables to make the module ready for a new job request.

Note: The function `Ea_Cancel` and the cancel function of the underlying EEPROM driver are asynchronous w.r.t. an ongoing read, erase or write job in the EEPROM memory. The cancel functions shall only reset their modules internal variables so that a new job can be accepted by the modules. They do not cancel an ongoing job in the hardware and they do not wait for an ongoing job to be finished by the hardware. This might lead to the situation in which the module's state is reported as IDLE while there is still an ongoing job being executed by the hardware. Therefore, the EEPROM driver's main function shall check that the hardware is indeed free before starting a new job (see chapter 9.4 for a detailed sequence diagram).

8.3.6 Ea_GetStatus

EA089:

Service name:	Ea_GetStatus	
Syntax:	MemIf_StatusType Ea_GetStatus()	
Service ID[hex]:	0x05	
Sync/Async:	Synchronous	
Reentrancy:	Non Reentrant	
Parameters (in):	None	
Parameters (inout):	None	
Parameters (out):	None	
Return value:	MemIf_StatusType	MEMIF_UNINIT - The underlying EEPROM driver has not been initialized. MEMIF_IDLE - The underlying EEPROM driver is currently idle. MEMIF_BUSY - The underlying EEPROM driver is currently busy. MEMIF_BUSY_INTERNAL - The EA module is busy with internal management operations.
Description:	Service to return the Status.	

EA034: If no internal operation is currently ongoing, the function Ea_GetStatus shall call the “GetStatus” function of the underlying EEPROM driver and pass its return value back to the caller.

EA073: The function Ea_GetStatus shall return MEMIF_BUSY_INTERNAL, if an internal operation is currently ongoing. In this case the “GetStatus” function of the underlying driver shall not be called.

8.3.7 Ea_GetJobResult

EA090:

Service name:	Ea_GetJobResult	
Syntax:	MemIf_JobResultType Ea_GetJobResult()	
Service ID[hex]:	0x06	
Sync/Async:	Synchronous	
Reentrancy:	Non Reentrant	
Parameters (in):	None	
Parameters (inout):	None	
Parameters (out):	None	
Return value:	MemIf_JobResultType	MEMIF_JOB_OK - The last job has been finished successfully. MEMIF_JOB_PENDING - The last job is waiting for execution or currently being executed. MEMIF_JOB_CANCELLED - The last job has been cancelled (which means it failed). MEMIF_JOB_FAILED - The last read/erase/write/compare job failed. MEMIF_BLOCK_INCONSISTENT - The requested block is inconsistent, it may contain corrupted data. MEMIF_BLOCK_INVALID - The requested block has been invalidated, the requested operation can not be performed.
Description:	Service to return the JobResult.	

EA035: The function Ea_GetJobResult shall call the “GetJobResult” function of the underlying EEPROM driver and pass the return value back to the caller.

8.3.8 Ea_InvalidateBlock

EA091:

Service name:	Ea_InvalidateBlock	
Syntax:	Std_ReturnType Ea_InvalidateBlock(uint16 BlockNumber)	
Service ID[hex]:	0x07	
Sync/Async:	Asynchronous	
Reentrancy:	Non Reentrant	
Parameters (in):	BlockNumber	Number of logical block, also denoting start address of that block in EEPROM.
Parameters (inout):	None	
Parameters (out):	None	
Return value:	Std_ReturnType	E_OK - The job was accepted by the underlying memory driver E_NOT_OK - The job has not been accepted by the underlying memory driver
Description:	Invalidates the block BlockNumber.	

EA036: The function `Ea_InvalidateBlock` shall take the block number and calculate the corresponding memory block address.

EA037: The function `Ea_InvalidateBlock` shall invalidate the block `<BlockNumber>` by either calling the erase function of the underlying device driver or changing some module internal management information accordingly.

Note: This internal management information has to be stored in NV memory since it has to be resistant against resets. What this information is and how it is stored is not further detailed by this specification.

8.3.9 Ea_GetVersionInfo

EA092:

Service name:	Ea_GetVersionInfo	
Syntax:	<pre>void Ea_GetVersionInfo(Std_VersionInfoType* VersionInfoPtr)</pre>	
Service ID[hex]:	0x08	
Sync/Async:	Synchronous	
Reentrancy:	Non Reentrant	
Parameters (in):	None	
Parameters (inout):	None	
Parameters (out):	VersionInfoPtr	Pointer to standard version information structure.
Return value:	None	
Description:	Service to get the version information of this module.	

EA061: The function `Ea_GetVersionInfo` shall return the version information of this module. The version information includes:

- Module Id
- Vendor Id
- Vendor specific version numbers (BSW00407).

EA062: The function `Ea_GetVersionInfo` shall be pre compile time configurable On/Off by the configuration parameter `EA_VERSION_INFO_API`.

EA082: If source code for caller and callee of the function `Ea_GetVersionInfo` is available, the Ea module should realize this function as a macro, defined in the modules header file.

8.3.10 Ea_EraseImmediateBlock

EA093:

Service name:	Ea_EraseImmediateBlock	
Syntax:	Std_ReturnType Ea_EraseImmediateBlock(uint16 BlockNumber)	
Service ID[hex]:	0x09	
Sync/Async:	Asynchronous	
Reentrancy:	Non Reentrant	
Parameters (in):	BlockNumber	Number of logical block, also denoting start address of that block in EEPROM.
Parameters (inout):	None	
Parameters (out):	None	
Return value:	Std_ReturnType	E_OK - The addressed block has been erased. E_NOT_OK - The addressed block could not be erased.
Description:	Erases the block BlockNumber.	

EA063: The function Ea_EraseImmediateBlock shall take the block number and calculate the corresponding memory block address.

EA064: The function Ea_EraseImmediateBlock shall ensure that the EA module can write immediate data. Whether this involves physically erasing a memory area and therefore calling the erase function of the underlying driver depends on the implementation.

EA065: If development error detection for the EA module is enabled, the function Ea_EraseImmediateBlock shall check whether the addressed logical block is configured as containing immediate data (configuration parameter EaImmediateData == TRUE). If not, the function Ea_EraseImmediateBlock shall report the error code EA_E_INVALID_BLOCK_NO to the DET, shall not erase the addressed logical block and shall return E_NOT_OK.

Note: The function Ea_EraseImmediateBlock shall only be called by e.g. diagnostic or similar system service to pre-erase the area for immediate data if necessary.

8.4 Call-back notifications

This chapter lists all functions provided by the Ea module to lower layer modules.

EA114: The Ea module shall provide function prototypes of the callback functions in the file Ea_Cbk.h

Note: Depending on the implementation of the modules making up the NV memory stack, callback routines provided and/or invoked by the EA module may be called on

interrupt level. The EA module providing those routines therefore has to make sure that their runtime is reasonably short, i.e. since callbacks may be propagated upward through several software layers.

Note: Whether callback routines are allowable / feasible on interrupt level depends on the project specific needs (reaction time) and limitations (runtime in interrupt context). Therefore system design has to make sure that the configuration of the involved modules meets those requirements.

8.4.1 Nvm_JobEndNotification

EA094:

Service name:	NvM_JobEndNotification
Syntax:	void NvM_JobEndNotification()
Service ID[hex]:	0x10
Sync/Async:	Synchronous
Reentrancy:	Non Reentrant
Parameters (in):	None
Parameters (inout):	None
Parameters (out):	None
Return value:	None
Description:	Service to report this module the successful end of an asynchronous operation.

EA050: The underlying EEPROM driver shall call the function `Ea_JobEndNotification` to report the successful end of an asynchronous operation.

EA051: The function `NvM_JobEndNotification` shall perform any necessary block management operations and shall call the corresponding callback routine of the upper layer module.

EA101: The function `NvM_JobEndNotification` shall be callable on interrupt level.

8.4.2 Nvm_JobErrorNotification

EA095:

Service name:	NvM_JobErrorNotification
Syntax:	void NvM_JobErrorNotification())
Service ID[hex]:	0x11
Sync/Async:	Synchronous
Reentrancy:	Non Reentrant
Parameters (in):	None
Parameters (inout):	None
Parameters (out):	None
Return value:	None
Description:	Service to report this module the failure of an asynchronous operation.

EA052: The underlying EEPROM driver shall call the function `Ea_JobErrorNotification` to report the failure of an asynchronous operation.

EA053: The function `NvM_JobErrorNotification` shall perform any necessary block management and error handling operations and shall call the corresponding callback routine of the upper layer module.

EA102: The function `NvM_JobErrorNotification` shall be callable on interrupt level.

8.5 Scheduled functions

These functions are directly called by the Basic Software Scheduler. The following functions shall have no return value and no parameter. All functions shall be non re-entrant.

8.5.1 Ea_MainFunction

EA096:

Service name:	Ea_MainFunction
Syntax:	void Ea_MainFunction())
Service ID[hex]:	0x12
Timing:	ON_PRE_CONDITION
Description:	Service to handle the requested jobs and the internal management operations.

EA056: The function `Ea_MainFunction` shall asynchronously handle the requested read / write / erase jobs respectively the internal management operations.

EA074: The function `Ea_MainFunction` shall check, whether the block requested for reading has been invalidated by the upper layer module. If so, the function `Ea_MainFunction` shall set the job result to `MEMIF_BLOCK_INVALID` and call the job error notification function if configured.

EA104: The function `Ea_MainFunction` shall check the consistency of the logical block being read before notifying the caller. If an inconsistency of the block is detected (see [EA046](#) and [EA047](#)), the function `Ea_MainFunction` shall set the job result to `MEMIF_BLOCK_INCONSISTENT` and call the error notification routine of the upper layer.

Note: In this case the upper layer shall not use the contents of the data buffer.

8.6 Expected Interfaces

In this chapter all interfaces required from other modules are listed.

8.6.1 Mandatory Interfaces

This chapter defines all interfaces which are required to fulfill the core functionality of the module.

EA097:

<i>API function</i>	<i>Description</i>
<code>Eep_SetMode</code>	Sets the mode.
<code>Eep_Erase</code>	Service for erasing EEPROM sections.
<code>Eep_Read</code>	Reads from EEPROM.
<code>Eep_Write</code>	Writes to EEPROM.
<code>Eep_GetStatus</code>	Returns the EEPROM status.
<code>Eep_GetJobResult</code>	This service returns the result of the last job.
<code>Eep_Cancel</code>	Cancels a running job.

8.6.2 Optional Interfaces

This chapter defines all interfaces which are required to fulfill an optional functionality of the module.

EA098:

<i>API function</i>	<i>Description</i>
<code>Det_ReportError</code>	Service to report development errors.

8.6.3 Configurable interfaces

In this chapter all interfaces are listed where the target function could be configured. The target function is usually a call-back function. The names of this kind of interfaces is not fixed because they are configurable.

WRONG NAMES → MH: This has to be fixed by generating the tables anew. Currently the import of those tables results in an error (Ungültiger Dateiname). TO, please check and advice.

EA099:

Service name:	NvM_JobEndNotification	
Syntax:	void NvM_JobEndNotification()	
Service ID[hex]:	0x10	
Sync/Async:	Synchronous	
Reentrancy:	Non Reentrant	
Parameters (in):	None	
Parameters (inout):	None	
Parameters (out):	None	
Return value:	None	
	Description:	Service to report this module the successful end of an asynchronous operation.

EA054: The Ea module shall call the function defined in the configuration parameter EA_JOB_END_NOTIFICATION upon successful end of an asynchronous operation after performing all necessary internal management operations.

- Read job finished & OK
- Write job finished & OK & block marked as valid
- Erase job for immediate data finished & OK (see [EA064](#))

EA106: The function defined in the configuration parameter EA_JOB_END_NOTIFICATION shall be callable on interrupt level.

EA100:

Service name:	NvM_JobErrorNotification
Syntax:	void NvM_JobErrorNotification()
Service ID[hex]:	0x11
Sync/Async:	Synchronous
Reentrancy:	Non Reentrant
Parameters (in):	None
Parameters (inout):	None
Parameters (out):	None
Return value:	None
Description:	Service to report this module the failure of an asynchronous operation.

EA055: The Ea module shall call the function defined in the configuration parameter EA_JOB_ERROR_NOTIFICATION upon failure of an asynchronous operation after performing all necessary internal management and error handling operations:

- Read job finished & failed (e.g. block invalid or inconsistent)
- Write job finished & failed & block marked as invalid
- Erase job for immediate data finished & failed (see [EA064](#))

EA107: The function defined in the configuration parameter EA_NVM_JOB_ERROR_NOTIFICATION shall be callable on interrupt level.

9 Sequence diagrams

Note: For a vendor specific library the following sequence diagrams are valid only insofar as they show the relation to the calling modules (Ecu_StateManager resp. memory abstraction interface). The calling relations from a memory abstraction module to an underlying driver are not relevant / binding for a vendor specific library.

9.1 Ea_Init

The following figure shows the call sequence for the Ea_Init routine. It is different from that of all other services of this module as it is not called by the NVRAM manager and not called via the memory abstraction interface.

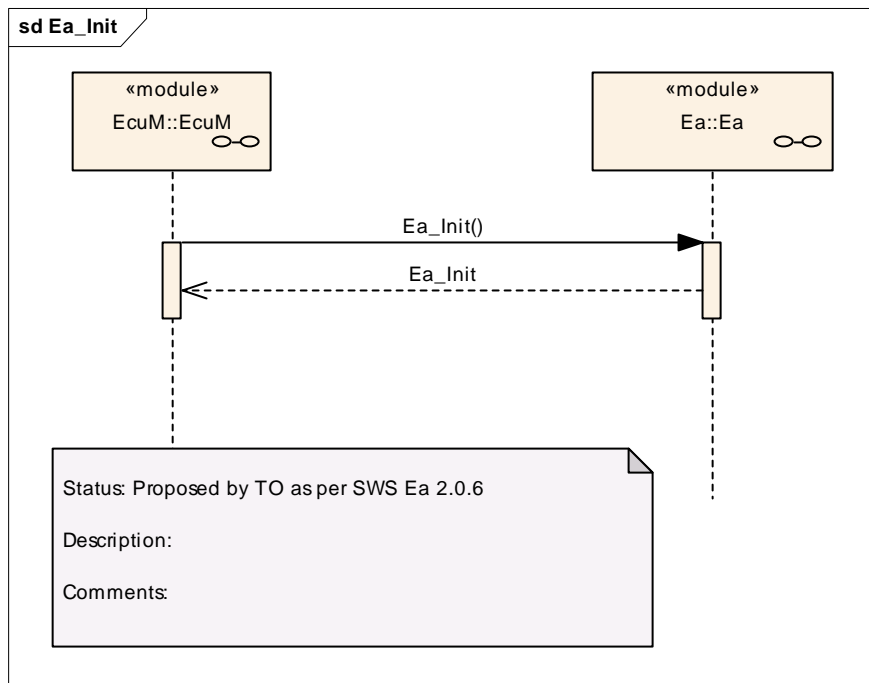

Figure 5: Sequence diagram of "Ea_Init" service

9.2 Ea_SetMode

The following figure shows as an example the call sequence for the Ea_SetMode service. This sequence diagram also applies to the other synchronous services of this module with exception of the Ea_Init routine (see above).

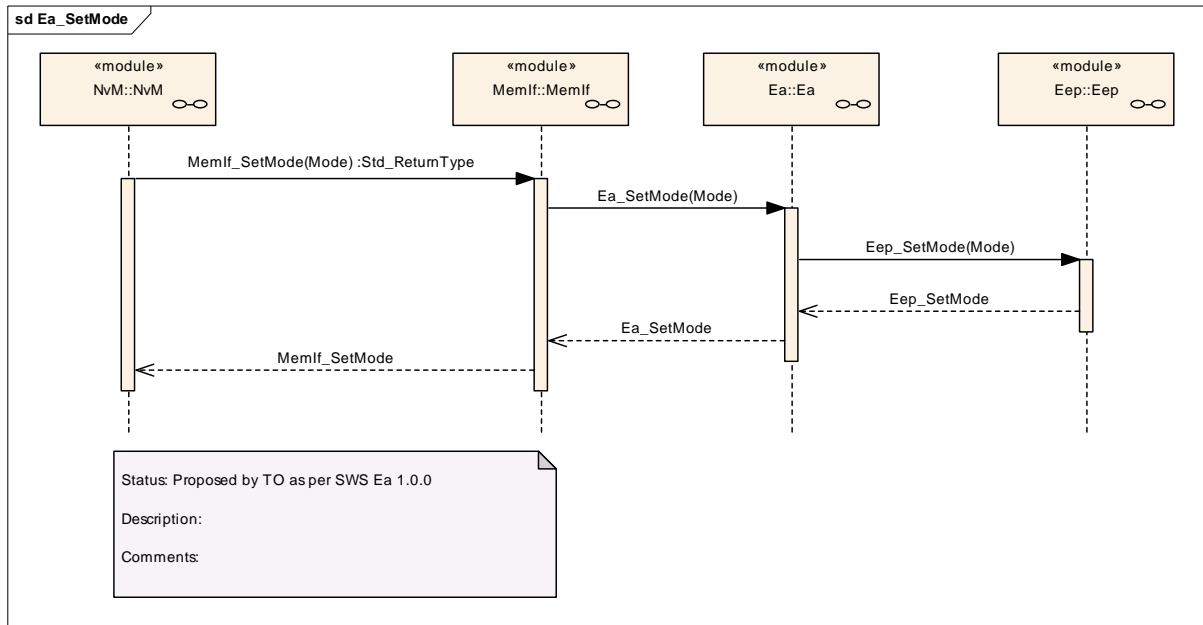

Figure 6: Sequence diagram of the "Ea_SetMode" service

9.3 Ea_Write

The following figure shows as an example the call sequence for the Ea_Write service. This sequence diagram also applies to the other asynchronous services of this module.

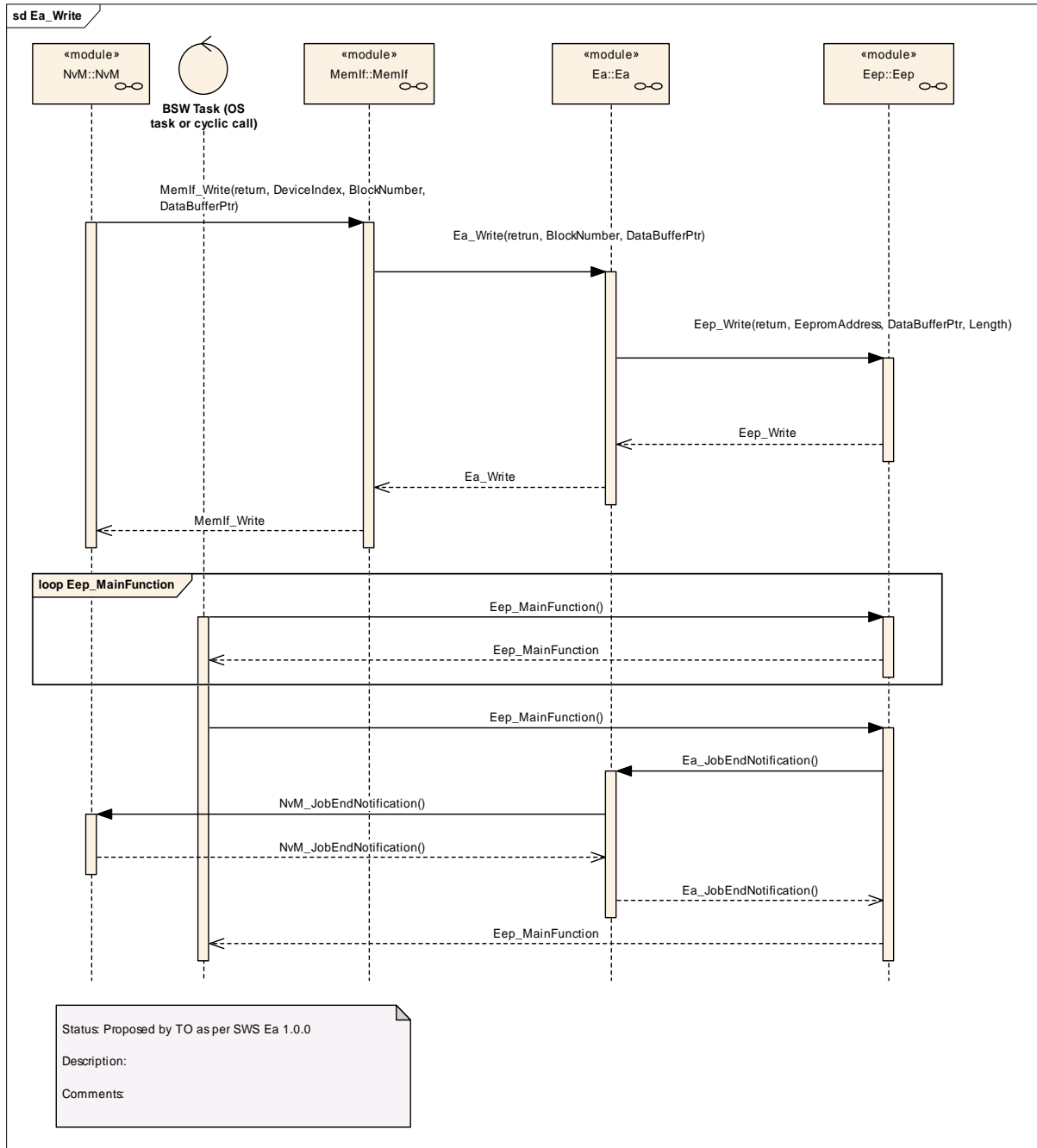
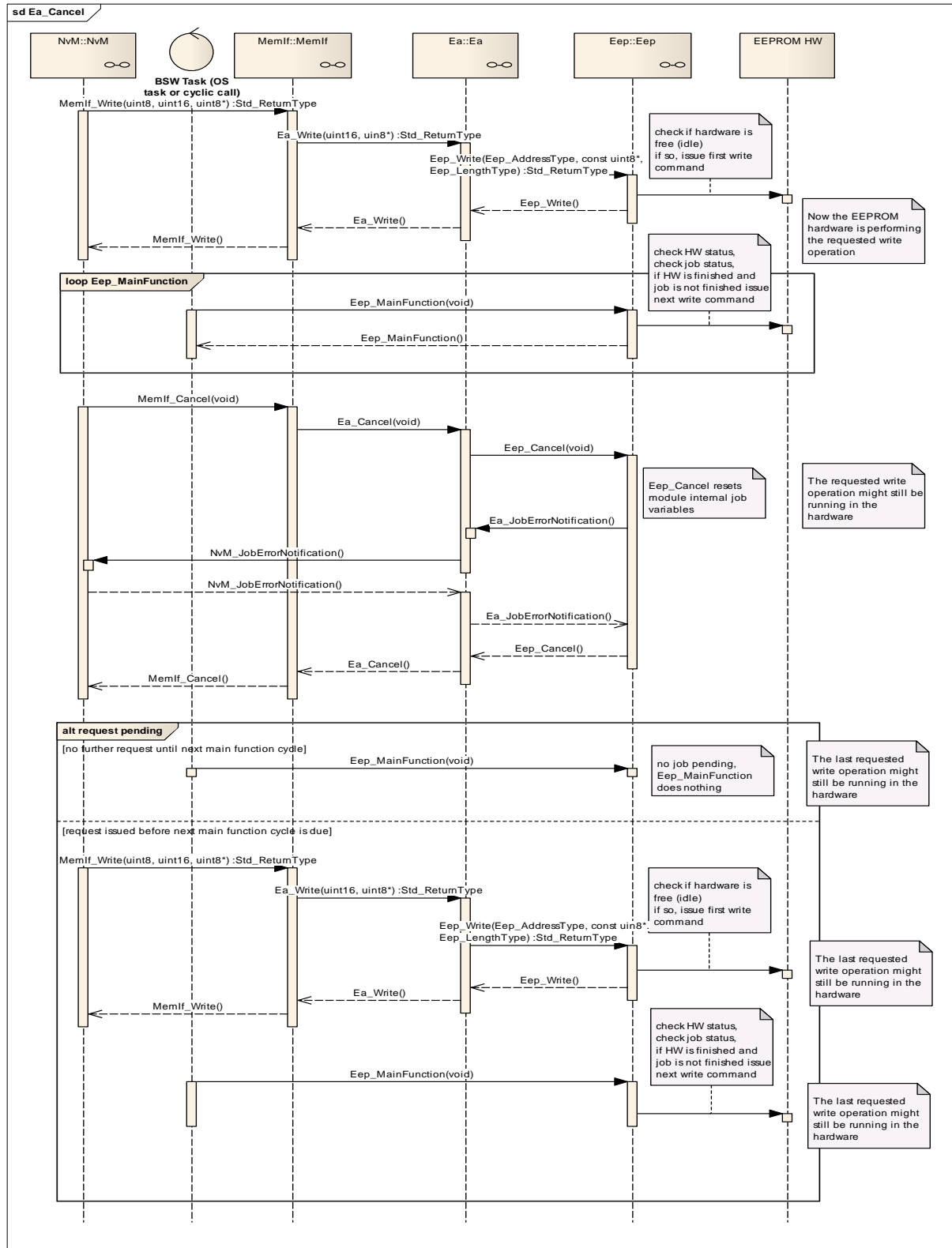

Figure 7: Sequence diagram "Ea_Write"

9.4 Ea_Cancel

The following figure shows as an example the call sequence for a cancelled Ea_Write service. This sequence diagram shows that Ea_Cancel is asynchronous w.r.t. the underlying hardware while itself being synchronous.



10 Configuration specification

10.1 How to read this chapter

In addition to this section, it is highly recommended to read the documents:

- AUTOSAR Layered Software Architecture [2]
 - AUTOSAR ECU Configuration Specification [7]
- This document describes the AUTOSAR configuration methodology and the AUTOSAR configuration metamodel in detail.

The following is only a short survey of the topic and it will not replace the ECU Configuration Specification document.

10.1.1 Configuration and configuration parameters

Configuration parameters define the variability of the generic part(s) of an implementation of a module. This means that only generic or configurable module implementation can be adapted to the environment (software/hardware) in use during system and/or ECU configuration.

The configuration of parameters can be achieved at different times during the software process: before compile time, before link time or after build time. In the following, the term “configuration class” (of a parameter) shall be used in order to refer to a specific configuration point in time.

10.1.2 Containers

Containers structure the set of configuration parameters. This means:

- *all* configuration parameters are kept in containers.
- (sub-) containers can reference (sub-) containers. It is possible to assign a multiplicity to these references. The multiplicity then defines the possible number of instances of the contained parameters.

10.1.3 Specification template for configuration parameters

The following tables consist of three sections:

- the general section
- the configuration parameter section
- the section of included/referenced containers

Pre-compile time - specifies whether the configuration parameter shall be of configuration class *Pre-compile time* or not

Label	Description
x	The configuration parameter shall be of configuration class <i>Pre-compile time</i> .
--	The configuration parameter shall never be of configuration class <i>Pre-compile time</i> .

Link time - specifies whether the configuration parameter shall be of configuration class *Link time* or not

Label	Description
x	The configuration parameter shall be of configuration class <i>Link time</i> .
--	The configuration parameter shall never be of configuration class <i>Link time</i> .

Post Build - specifies whether the configuration parameter shall be of configuration class *Post Build* or not

Label	Description
x	The configuration parameter shall be of configuration class <i>Post Build</i> and no specific implementation is required.
L	<i>Loadable</i> - the configuration parameter shall be of configuration class <i>Post Build</i> and only one configuration parameter set resides in the ECU.
M	<i>Multiple</i> - the configuration parameter shall be of configuration class <i>Post Build</i> and is selected out of a set of multiple parameters by passing a dedicated pointer to the init function of the module.
--	The configuration parameter shall never be of configuration class <i>Post Build</i> .

10.2 Containers and configuration parameters

The following chapters summarize all configuration parameters. The detailed meanings of the parameters describe Chapters 7 and Chapter 8.

10.2.1 Variants

No variants specified.

10.2.2 Ea

Module Name	Ea
Module Description	Configuration of the Ea (EEPROM Abstraction) module. The module shall abstract from the device specific addressing scheme and segmentation and provide the upper layers with a virtual addressing scheme and segmentation as well as a "virtually" unlimited number of erase cycles.

Included Containers		
Container Name	Multiplicity	Scope / Dependency
EaBlockConfiguration	1..*	Configuration of block specific parameters for the EEPROM abstraction module.
EaGeneral	1	General configuration of the EEPROM abstraction module. This container lists block independent configuration parameters.
EaPublishedInformation	1	Additional published parameters not covered by CommonPublishedInformation container. Note that these parameters do not have any configuration class setting, since they are published information.

10.2.3 EaBlockConfiguration

SWS Item	EA040 :
Container Name	EaBlockConfiguration{EA_BlockConfiguration}
Description	Configuration of block specific parameters for the EEPROM abstraction module.
Configuration Parameters	

SWS Item	EA116 :		
Name	EaBlockNumber {EA_BLOCK_NUMBER}		
Description	Block identifier (handle). 0x0000 and 0xFFFF shall not be used for block numbers (see EA006). Range: min = 2 ^{NVM_DATA_SELECTION_BITS} max = 0xFFFF -2 ^{NVM_DATA_SELECTION_BITS} Note: Depending on the number of bits set aside for dataset selection several other block numbers shall also be left out to ease implementation.		
Multiplicity	1		
Type	IntegerParamDef (Symbolic Name generated for this parameter)		
Range	0 .. 65535		
Default value	--		
ConfigurationClass	Pre-compile time	X	All Variants
	Link time	--	
	Post-build time	--	
Scope / Dependency	scope: module		

SWS Item	EA117 :		
Name	EaBlockSize {EA_BLOCK_SIZE}		
Description	Size of a logical block in bytes.		
Multiplicity	1		
Type	IntegerParamDef		
Range	0 .. 65535		
Default value	--		
ConfigurationClass	Pre-compile time	X	All Variants
	Link time	--	
	Post-build time	--	

Scope / Dependency	scope: module
---------------------------	---------------

SWS Item	EA118 :		
Name	EaImmediateData {EA_IMMEDIATE_DATA}		
Description	Marker for high priority data. true: Block contains immediate data. false: Block does not contain immediate data.		
Multiplicity	1		
Type	BooleanParamDef		
Default value	--		
ConfigurationClass	Pre-compile time	X	All Variants
	Link time	--	
	Post-build time	--	
Scope / Dependency	scope: module		

SWS Item	EA119 :		
Name	EaNumberOfWriteCycles {EA_NUMBER_OF_WRITE_CYCLES}		
Description	Number of write cycles required for this block.		
Multiplicity	1		
Type	IntegerParamDef		
Default value	--		
ConfigurationClass	Pre-compile time	X	All Variants
	Link time	--	
	Post-build time	--	
Scope / Dependency	scope: module		

SWS Item	EA115 :		
Name	EaDeviceIndex {EA_DEVICE_INDEX}		
Description	Device index (handle). Range: 0 .. 254 (0xFF reserved for broadcast call to GetStatus function).		
Multiplicity	1		
Type	Reference to EepGeneral		
ConfigurationClass	Pre-compile time	X	All Variants
	Link time	--	
	Post-build time	--	
Scope / Dependency	scope: module dependency: This information is needed by the NVRAM manager respectively the Memory Abstraction Interface to address a certain logical block. It is listed in this specification to give a complete overview over all block related configuration parameters.		

No Included Containers

10.3 Published Information

Published information contains data defined by the implementer of the SW module that does not change when the module is adapted (i.e. configured) to the actual HW/SW environment. It thus contains version and manufacturer information.

The standard common published information like

- vendorId EA_VENDOR_ID),
- moduleId (EA_MODULE_ID),
- arMajorVersion EA_AR_MAJOR_VERSION),

- arMinorVersion (EA_AR_MINOR_VERSION),
- arPatchVersion (EA_AR_PATCH_VERSION),
- swMajorVersion (EA_SW_MAJOR_VERSION),
- swMinorVersion (EA_SW_MINOR_VERSION),
- swPatchVersion (EA_SW_PATCH_VERSION),
- vendorApiInfix (EA_VENDOR_API_INFIX)

is provided in the BSW Module Description Template (see [8], Figure 4.1 and Figure 7.1). Additional published parameters are listed below if applicable for this module.

10.3.1 EaPublishedInformation

SWS Item	EA043 :
Container Name	EaPublishedInformation
Description	Additional published parameters not covered by CommonPublishedInformation container. Note that these parameters do not have any configuration class setting, since they are published information.
Configuration Parameters	

SWS Item	EA126 :									
Name	EaBlockOverhead {EA_BLOCK_OVERHEAD}									
Description	Management overhead per logical block in bytes. Note: If the management overhead depends on the block size or block location a formula has to be provided that allows the configurator to calculate the management overhead correctly.									
Multiplicity	1									
Type	IntegerParamDef									
Default value	--									
ConfigurationClass	<table border="1"> <tr> <td>Pre-compile time</td> <td>--</td> <td></td> </tr> <tr> <td>Link time</td> <td>--</td> <td></td> </tr> <tr> <td>Post-build time</td> <td>--</td> <td></td> </tr> </table>	Pre-compile time	--		Link time	--		Post-build time	--	
Pre-compile time	--									
Link time	--									
Post-build time	--									
Scope / Dependency	scope: module									

SWS Item	EA070 :									
Name	EaMaximumBlockingTime {EA_MAXIMUM_BLOCKING_TIME}									
Description	The maximum time the EA module's API routines shall be blocked (delayed) by internal operations. (EA070) Note: Internal operations in that case means operations that are not explicitly invoked from the upper layer module but need to be handled for proper operation of this module or the underlying memory driver.									
Multiplicity	1									
Type	FloatParamDef									
Default value	--									
ConfigurationClass	<table border="1"> <tr> <td>Pre-compile time</td> <td>X</td> <td>All Variants</td> </tr> <tr> <td>Link time</td> <td>--</td> <td></td> </tr> <tr> <td>Post-build time</td> <td>--</td> <td></td> </tr> </table>	Pre-compile time	X	All Variants	Link time	--		Post-build time	--	
Pre-compile time	X	All Variants								
Link time	--									
Post-build time	--									
Scope / Dependency	scope: module									

SWS Item	EA127 :
Name	EaPageOverhead {EA_PAGE_OVERHEAD}
Description	Management overhead per page in bytes. Note: If the management overhead depends on the block size or block location a formula has to be provided that allows the configurator to calculate the management

	overhead correctly.		
Multiplicity	1		
Type	IntegerParamDef		
Default value	--		
ConfigurationClass	Pre-compile time	--	
	Link time	--	
	Post-build time	--	
Scope / Dependency	scope: module		

No Included Containers

11 Changes during SWS Improvements by Technical Office

11.1 Deleted SWS Items

<i>SWS Item</i>	<i>Rationale</i>
EA003	No requirement, statement left in
EA004	No requirement, statement left in
EA001	No requirement, statement left in

11.2 Replaced SWS Items

<i>SWS Item of Release</i>	<i>replaced by SWS Item</i>	<i>Rationale</i>
EA033	<u>EA077</u> , <u>EA078</u>	Made requirement atomic
EA008	<u>EA079</u> , <u>EA080</u>	Made requirement atomic
EA015, EA016	<u>EA083</u>	UML Model linking of imported types
EA069	<u>EA101</u> , <u>EA102</u>	Made requirement atomic and avoided redundancies
EA023	<u>EA104</u> , <u>EA105</u>	Made requirement atomic
EA002	EA112, EA113	Made requirement more atomic

11.3 Changed SWS Items

Many requirements have been changed to improve understanding, without modification to the technical contents

<i>SWS Item</i>	<i>Rationale</i>
EA057	RfC #17166: Replaced with appropriate wording from SWS template

11.4 Added SWS Items

SWS Item	Rationale
EA076	Caveat for Ecu_Init.
EA081	Standard requirement for every module.
EA082	Hint in Ea_GetVersionInfo
EA084	UML Model linking of Ea_Init
EA085	UML Model linking of Ea_SetMode
EA0 6	UML Model linking of Ea_Read
EA087	UML Model linking of Ea_Write
EA088	UML Model linking of Ea_Cancel
EA089	UML Model linking of Ea_GetStatus
EA090	UML Model linking of Ea_GetJobResult
EA091	UML Model linking of Ea_InvalidateBlock
EA092	UML Model linking of Ea_GetVersionInfo
EA093	UML Model linking of Ea_EraseImmediateBlock
EA094	UML Model linking of Ea_JobEndNotification
EA095	UML Model linking of Ea_JobErrorNotification
EA096	UML Model linking of Ea_MainFunction
EA097	UML Model linking of mandatory interfaces
EA098	UML Model linking of optional interfaces
EA099	UML Model linking of NvM_JobEndNotification
EA100	UML Model linking of NvM_JobErrorNotification
EA106	Gave ID to existing requirement
EA107	Gave ID to existing requirement
EA114	Gave ID to existing requirement
EA115	RfC #18566: Requirement added for clarification