

<b>Document Title</b>	Specification of ADC Driver
<b>Document Owner</b>	AUTOSAR GbR
<b>Document Responsibility</b>	AUTOSAR GbR
<b>Document Identification No</b>	010
<b>Document Classification</b>	Standard

<b>Document Version</b>	3.0.2
<b>Document Status</b>	Final
<b>Part of Release</b>	3.1
<b>Revision</b>	0001

<b>Document Change History</b>			
<b>Date</b>	<b>Version</b>	<b>Changed by</b>	<b>Change Description</b>
23.06.2008	3.0.2	AUTOSAR Administration	Legal disclaimer revised
22.01.2008	3.0.1	AUTOSAR Administration	• Correction of: Table of Content

<b>Document Change History</b>			
<b>Date</b>	<b>Version</b>	<b>Changed by</b>	<b>Change Description</b>
13.12.2007	3.0.0	AUTOSAR Administration	<ul style="list-style-type: none"> <li>• New API Adc_ReadGroup introduced</li> <li>• Removed API Adc_ValueReadGroup</li> <li>• Modified API Adc_GetStreamLastPointer</li> <li>• New configuration parameter added</li> <li>*AdcGroupReplacement</li> <li>*AdcPriorityImplementation</li> <li>*AdcResultBufferPointer</li> <li>*AdcEnableQueuing</li> <li>*AdcReadGroupApi</li> <li>• Cconfiguration parameter removed</li> <li>*ADC_GRP_PRIORITY_IMP_LEVEL</li> <li>*ADC_STREAMING_BUFFER_POINTER</li> <li>• Priority mechanism improved</li> <li>• Type definitions modified and extended</li> <li>• State diagrams added</li> <li>• New state transitions defined</li> <li>• New state ADC_STREAM_COMPLETED added</li> <li>• State based requirements added</li> <li>• Sequence charts modified and extended</li> <li>• ADC buffer access mode example added</li> <li>• New DET's defined</li> <li>*new DET ADC_E_ALREADY_INITIALIZED</li> <li>*new DET ADC_E_PARAM_CONFIG</li> <li>*new DET ADC_E_BUFFER_UNINIT</li> <li>• Part of existing requirments reformulated</li> <li>• Added new requirement ID's ADC321-ADC43'</li> <li>• Document meta information extended</li> <li>• Small layout adaptations made</li> </ul>
24.01.2007	2.1.1	AUTOSAR Administration	<ul style="list-style-type: none"> <li>• "Advice for users" revised</li> <li>• "Revision Information" added</li> </ul>

<b>Document Change History</b>			
<b>Date</b>	<b>Version</b>	<b>Changed by</b>	<b>Change Description</b>
23.11.2006	2.1.0	AUTOSAR Administration	<ul style="list-style-type: none"><li>• Removed the "On Demand" functionality. Related services not available anymore.</li><li>• Removed the "Gated Continuous" conversion mode. Related services not available anymore.</li><li>• Removed the distinction between internal and external hardware trigger.</li><li>• Introduced a priority mechanism for channel groups for allowing channel groups with higher priority to interrupt ongoing conversions (can cover also the "On demand" functionality).</li><li>• Reworked the "Streaming Access Mode". A dedicated data structure for the returned values of a conversion is now clearly defined.</li><li>• Conversion values access now allowed only through channel groups (no single channel value available. Related service not available anymore).</li></ul>
27.03.2006	2.0.0	AUTOSAR Administration	Document structure adapted to common Release 2.0 SWS Template.
30.06.2005	1.0.0	AUTOSAR Administration	Initial Release.

Page left intentionally blank

## Disclaimer

This document of a specification as released by the AUTOSAR Development Partnership is intended **for the purpose of information only**. The commercial exploitation of material contained in this specification requires membership of the AUTOSAR Development Partnership or an agreement with the AUTOSAR Development Partnership. The AUTOSAR Development Partnership will not be liable for any use of this specification. Following the completion of the development of the AUTOSAR specifications commercial exploitation licenses will be made available to end users by way of written License Agreement only.

No part of this publication may be reproduced or utilized in any form or by any means, electronic or mechanical, including photocopying and microfilm, without permission in writing from the publisher." The word AUTOSAR and the AUTOSAR logo are registered trademarks.

Copyright © 2004-2008 AUTOSAR Development Partnership. All rights reserved.

## Advice to users of AUTOSAR Specification Documents:

AUTOSAR Specification Documents may contain exemplary items (exemplary reference models, "use cases", and/or references to exemplary technical solutions, devices, processes or software).

Any such exemplary items are contained in the Specification Documents for illustration purposes only, and they themselves are not part of the AUTOSAR Standard. Neither their presence in such Specification Documents, nor any later documentation of AUTOSAR conformance of products actually implementing such exemplary items, imply that intellectual property rights covering such exemplary items are licensed under the same rules as applicable to the AUTOSAR Standard.

## Table of Contents

1	Introduction and functional overview .....	10
2	Acronyms and abbreviations .....	11
3	Related documentation .....	12
3.1	Input documents.....	12
4	Constraints and assumptions .....	14
4.1	Limitations .....	14
4.2	Applicability to car domains.....	14
5	Dependencies to other modules.....	15
5.1	File structure .....	15
5.1.1	Code file structure .....	15
5.1.2	Header file structure .....	15
6	Requirements traceability.....	17
7	Functional specification .....	24
7.1	General behavior.....	24
7.1.1	Background & Rationale .....	24
7.1.2	Requirements.....	24
7.1.3	ADC Buffer Access Mode Example.....	29
7.1.3.1	Example: Configuration .....	30
7.1.3.2	Example: Initialization .....	30
7.1.3.3	Example: Adc_GetStreamLastPointer Usage .....	30
7.1.3.4	Example: Adc_ReadGroup Usage .....	31
7.2	Conversion processing and interaction .....	32
7.2.1	Background & Rationale .....	32
7.2.2	Requirements.....	33
7.3	State Diagrams .....	34
7.3.1	ADC State Diagram for One-Shot/Continuous Group Conversion Mode ....	34
7.3.2	ADC State Diagram for HW/SW Trigger in One-Shot Group Conversion Mode.....	35
7.3.3	ADC State Diagram for SW Trigger in Continuous Conversion Mode.....	36
7.3.4	ADC State Diagram for One-Shot Conversion Mode, Software Trigger Source, Single Access Mode .....	37
7.3.5	ADC State Diagram for One-Shot Conversion, Hardware Trigger Source, Single Access Mode .....	38
7.3.6	ADC State Diagram for One-Shot Conversion Mode, Hardware Trigger Source, Linear and Circular Streaming Access Mode.....	39
7.3.7	ADC State Diagram for Continuous Conversion Mode, Software Trigger Source, Single Access Mode .....	40
7.3.8	ADC State Diagram for Continuous Conversion Mode, Software Trigger Source, Linear and Circular Streaming Access Mode.....	41
7.4	Version check.....	42
7.4.1	Background & Rationale .....	42
7.4.2	Requirements.....	42
7.5	Error classification.....	42

7.6	Error detection.....	44
7.7	Error notification .....	47
8	API specification.....	48
8.1	Imported types .....	48
8.2	Type definitions .....	48
8.2.1	Adc_ConfigType.....	48
8.2.2	Adc_ChannelType.....	48
8.2.3	Adc_GroupType .....	48
8.2.4	Adc_ValueGroupType .....	48
8.2.5	Adc_ClockSourceType.....	49
8.2.6	Adc_PrescaleType .....	49
8.2.7	Adc_ConversionTimeType .....	49
8.2.8	Adc_SamplingTimeType .....	49
8.2.9	Adc_VoltageSourceType.....	50
8.2.10	Adc_ResolutionType .....	50
8.2.11	Adc_StatusType.....	50
8.2.12	Adc_TriggerSourceType .....	50
8.2.13	Adc_GroupConvModeType.....	50
8.2.14	Adc_GroupPriorityType .....	51
8.2.15	Adc_GroupDefType .....	51
8.2.16	Adc_StreamNumSampleType.....	51
8.2.17	Adc_HwUnitType .....	51
8.2.18	Adc_StreamBufferModeType .....	51
8.2.19	Adc_GroupAccessModeType.....	52
8.2.20	Adc_HwTriggerSignalType.....	52
8.2.21	Adc_HwTriggerTimerType .....	52
8.2.22	Adc_PriorityImplementationType .....	53
8.2.23	Adc_GroupReplacementType .....	53
8.3	Function definitions .....	54
8.3.1	Adc_Init .....	54
8.3.2	Adc_SetupResultBuffer .....	56
8.3.3	Adc_DeInit.....	57
8.3.4	Adc_StartGroupConversion .....	58
8.3.5	Adc_StopGroupConversion.....	61
8.3.6	Adc_ReadGroup .....	63
8.3.7	Adc_EnableHardwareTrigger .....	65
8.3.8	Adc_DisableHardwareTrigger .....	67
8.3.9	Adc_EnableGroupNotification .....	69
8.3.10	Adc_DisableGroupNotification .....	70
8.3.11	Adc_GetGroupStatus .....	71
8.3.12	Adc_GetStreamLastPointer.....	73
8.3.13	Adc_GetVersionInfo .....	75
8.4	Call-back Notifications.....	75
8.5	Scheduled functions .....	75
8.6	Expected Interfaces .....	76
8.6.1	Mandatory Interfaces .....	76
8.6.2	Optional Interfaces .....	76
8.6.3	Configurable interfaces .....	76
9	Sequence diagrams .....	78

9.1	Initialization of the ADC Driver .....	78
9.2	De-Initialization of the ADC Driver.....	79
9.3	Software triggered One-Shot conversion without notification .....	80
9.4	Software triggered continuous conversion with notification .....	81
9.5	Hardware triggered One-Shot conversion with notification.....	82
9.6	HW Trigger - One-Shot conversion - Linear Streaming.....	83
9.7	No Priority Mechanism – No Queuing .....	84
9.8	No Priority Mechanism – SW Queuing .....	85
9.9	HW_SW Priority Mechanism – SW Queuing.....	86
9.10	HW Priority Mechanism – HW Queuing .....	87
9.11	HW_SW Priority Mechanism – HW/SW Queuing .....	88
10	Configuration specification .....	90
10.1	How to read this chapter .....	90
10.1.1	Configuration and configuration parameters .....	90
10.1.2	Containers.....	90
10.1.3	Specification template for configuration parameters .....	91
10.2	Configuration and configuration parameters .....	91
10.2.1	Variants.....	91
10.2.2	Adc.....	91
10.2.3	AdcGeneral .....	92
10.2.4	AdcConfigSet .....	94
10.2.5	AdcChannel.....	95
10.2.6	AdcGroup .....	96
10.2.7	AdcHwUnit .....	102
10.3	Published information.....	103
10.3.1	AdcPublishedInformation .....	103
10.4	Configuration of symbolic names .....	104
11	Changes to Release 1 .....	105
11.1	Deleted SWS Items .....	105
11.2	Replaced SWS Items .....	105
11.3	Changed SWS Items.....	105
11.4	Added SWS Items.....	106
12	Changes to Release 2.0.0.....	109
12.1	Deleted SWS Items .....	109
12.2	Replaced SWS Items .....	109
12.3	Changed SWS Items.....	109
12.4	Added SWS Items.....	110
13	Changes to Release 2.0.1 .....	111
13.1	Deleted SWS Items .....	111
13.2	Replaced SWS Items .....	111
13.3	Changed SWS Items.....	111
13.4	Added SWS Items.....	111
14	Changes to Release 2.1.1 .....	113
14.1	Deleted SWS Items .....	113
14.2	Replaced SWS Items .....	113
14.3	Changed SWS Items.....	113



14.4	Added SWS Items.....	114
15	Changes during SWS Improvements by Technical Office.....	115
15.1	Deleted SWS Items.....	115
15.2	Replaced SWS Items.....	115
15.3	Changed SWS Item.....	115
15.4	Added SWS Items.....	115
16	Changes to Release 2.1.3.....	116
16.1	Deleted SWS Items.....	116
16.2	Replaced SWS Items.....	116
16.3	Changed SWS Item.....	116
16.4	Added SWS Items.....	117
17	Changes to Release 2.1.4.....	118
17.1	Deleted SWS Items.....	118
17.2	Replaced SWS Items.....	118
17.3	Changed SWS Item.....	118
17.4	Added SWS Items.....	118

## 1 Introduction and functional overview

This specification describes the functionality, API and the configuration of the AUTOSAR Basic Software module ADC Driver.

The ADC module initializes and controls the internal Analogue Digital Converter Unit(s) of the microcontroller. It provides services to start and stop a conversion respectively to enable and disable the trigger source for a conversion. Furthermore it provides services to enable and disable a notification mechanism and routines to query the status and result of a conversion.

The ADC module works on so called ADC Channel Groups, which are build from so called ADC Channels. An ADC Channel Group combines an analogue input pin (ADC Channel), the needed ADC circuitry itself and conversion result register into an entity that can be individually controlled and accessed via the ADC module.

## 2 Acronyms and abbreviations

<b>Abbreviation / Acronym:</b>	<b>Description:</b>
DEM	Diagnostic Event Manager
DET	Development Error Tracer
ADC	Analogue Digital Converter
MCU	Microcontroller Unit
API	Application Programming Interface
HW	Hardware
SW	Software
ADC HW Unit	Represents a microcontroller input electronic device that includes all parts necessary to perform an “analogue to digital conversion”.
ADC Module	ADC Basic Software module ADC Driver, abbreviated also with ADC Driver
ADC Channel	Represents a logical ADC entity bound to one port pin. Multiple ADC entities can be mapped to the same port pin.
ADC Channel Group	A group of ADC channels linked to the same ADC hardware unit (e.g. one Sample&Hold and one A/D converter). The conversion of the whole group is triggered by one trigger source.
ADC Result Buffer (ADC Streaming Buffer, ADC Stream Buffer)	The user of the ADC Driver has to provide a buffer for every group. This buffer can hold multiple samples of the same group channel if streaming access mode is selected. If single access mode is selected one sample of each group channel is held in the buffer.
Software Trigger	Software API call that starts the conversion of one ADC channel group or a continuous series of ADC channel group conversions.
Hardware Trigger	ADC internal trigger signal that starts one conversion of an ADC channel group. ADC hardware trigger are generated internally in the ADC hardware, e.g. based on an ADC timer or a trigger edge signal. The trigger hardware is tightly coupled or integrated in the ADC hardware. No software is required to start the ADC channel group conversion after the hardware trigger is detected. <i>Note: If the ADC hardware does not support hardware trigger, a similar behavior can be realized with software trigger in combination with the GPT/ICU driver. E.g. in a GPT timer notification function a software triggered ADC channel group conversion can be started.</i>
Conversion Mode	<u>One-Shot:</u> The conversion of an ADC channel group is performed once after a trigger and the results are written to the assigned result buffer. A trigger can be a software API call or a hardware event. <u>Continuous:</u> The conversions of an ADC channel group are performed continuously after a software API call (start) and the results are written to the assigned result buffer. The conversions themselves are running automatically (hardware/interrupt controlled). The Continuous conversions can be stopped by a software API call (stop).
Sampling Time, Sample Time	Time during which the analogue value is sampled (e.g. loading the capacitor, ...)
Conversion Time	Time during which the sampled analogue value is converted into digital representation.
Acquisition Time	Sample Time + Conversion Time.

**Table 1: Acronyms and abbreviations used in this document**

### 3 Related documentation

#### 3.1 Input documents

- [1] General Requirements on Basic Software Modules,  
[https://svn2.autosar.org/repos2/22\\_Releases](https://svn2.autosar.org/repos2/22_Releases)  
AUTOSAR\_SRS\_General.pdf
- [2] General Requirements on SPAL,  
[https://svn2.autosar.org/repos2/22\\_Releases](https://svn2.autosar.org/repos2/22_Releases)  
AUTOSAR\_SRS\_SPAL\_General.pdf
- [3] Specification of Standard Types,  
[https://svn2.autosar.org/repos2/22\\_Releases](https://svn2.autosar.org/repos2/22_Releases)  
AUTOSAR\_SWS\_StandardTypes.pdf
- [4] List of Basic Software Modules,  
[https://svn2.autosar.org/repos2/22\\_Releases](https://svn2.autosar.org/repos2/22_Releases)  
AUTOSAR\_BasicSoftwareModules.pdf
- [5] Specification of Diagnostics Event Manager,  
[https://svn2.autosar.org/repos2/22\\_Releases](https://svn2.autosar.org/repos2/22_Releases)  
AUTOSAR\_SWS\_DEM.pdf
- [6] Specification of Development Error Tracer,  
[https://svn2.autosar.org/repos2/22\\_Releases](https://svn2.autosar.org/repos2/22_Releases)  
AUTOSAR\_SWS\_DET.pdf
- [7] Requirements on ADC Driver,  
[https://svn2.autosar.org/repos2/22\\_Releases](https://svn2.autosar.org/repos2/22_Releases)  
AUTOSAR\_SRS\_ADC\_Driver.pdf
- [8] Specification of ECU Configuration,  
[https://svn2.autosar.org/repos2/22\\_Releases](https://svn2.autosar.org/repos2/22_Releases)  
AUTOSAR\_ECU\_Configuration.pdf
- [9] Layered Software Architecture,  
[https://svn2.autosar.org/repos2/22\\_Releases](https://svn2.autosar.org/repos2/22_Releases)  
AUTOSAR\_LayeredSoftwareArchitecture.pdf
- [10] Specification of ECU State Manager,  
[https://svn2.autosar.org/repos2/22\\_Releases](https://svn2.autosar.org/repos2/22_Releases)  
AUTOSAR\_SWS\_ECU\_StateManager.pdf
- [11] Specification of I/O Hardware Abstraction,  
[https://svn2.autosar.org/repos2/22\\_Releases](https://svn2.autosar.org/repos2/22_Releases)  
AUTOSAR\_SWS\_IOHW\_Abstraction.pdf

- [12] AUTOSAR Basic Software Module Description Template,  
[https://svn2.autosar.org/repos2/22\\_Releases  
AUTOSAR\\_BSW\\_Module\\_Description.pdf](https://svn2.autosar.org/repos2/22_Releases/AUTOSAR_BSW_Module_Description.pdf)

## **4 Constraints and assumptions**

### **4.1 Limitations**

No limitations.

### **4.2 Applicability to car domains**

No restrictions.

## 5 Dependencies to other modules

### Module DET

**ADC354:** If development error detection for the ADC module is enabled: The ADC module shall raise errors to the Development Error Tracer (DET) whenever a development error is encountered by this module.

### Module DEM

**ADC355:** The ADC module shall report production errors to the Diagnostic Event Manager (DEM).

### Module MCU Driver

The Microcontroller Unit Driver (MCU Driver) is primarily responsible for initializing and controlling the chip's internal clock sources and clock prescalers. The clock frequency may affect:

- Trigger frequency
- Conversion time
- Sampling time

### Module PORT driver

**ADC379:** The PORT module shall configure the port pins used by the ADC module. Both analogue input pins and external trigger pins have to be considered.

## 5.1 File structure

### 5.1.1 Code file structure

**ADC240:** The code file structure shall not be defined within this specification completely. At this point it shall be pointed out that the code-file structure shall include the following file named:

- Adc\_PBcfg.c – for post build time configurable parameters.

This file shall contain all post-build time configurable parameters.

### 5.1.2 Header file structure

**ADC267:** The file include structure shall be as follows.

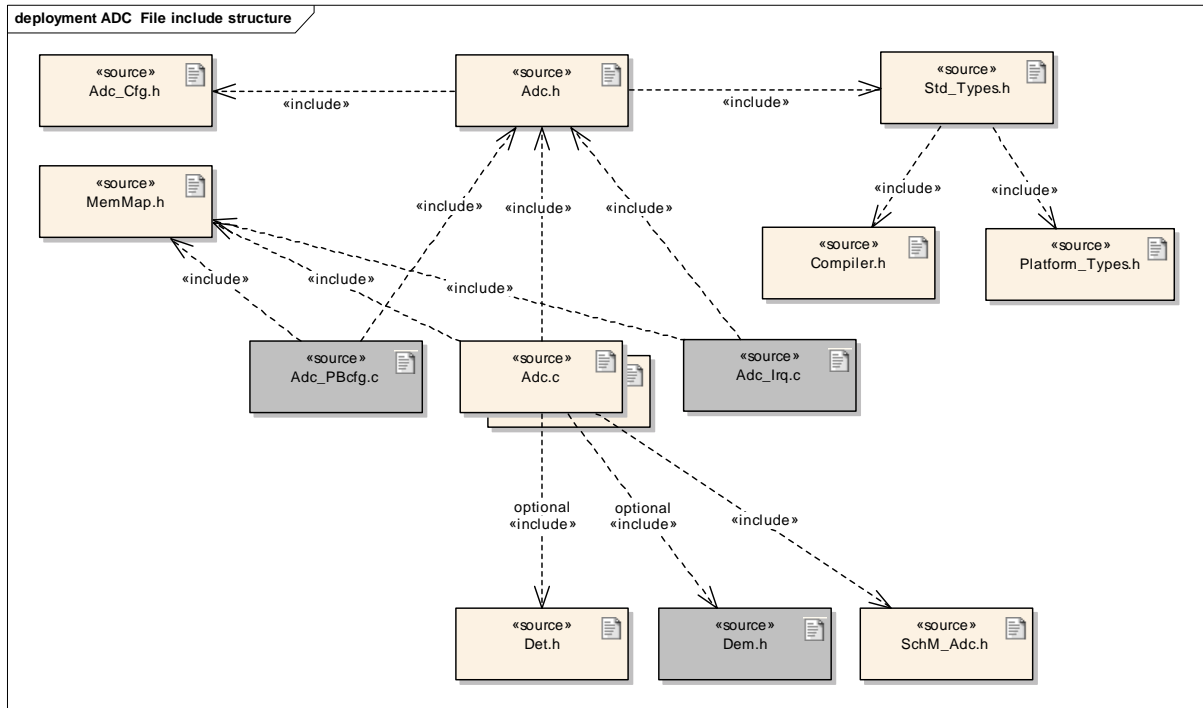

**Figure 1: ADC Driver file include structure**

**ADC239:** The module shall optionally include the Dem.h file if any production error will be issued by the implementation.

*Note:*

*By this inclusion the APIs to report errors as well as the required Event Id symbols are included. This specification defines the name of the Event Id symbols which are provided by XML to the DEM configuration tool. The DEM configuration tool assigns ECU dependent values to the Event Id symbols and publishes the symbols in Dem\_IntErrId.h.*



## 6 Requirements traceability

Document: General Requirements on Basic Software Modules

<b>Requirements</b>	<b>Satisfied</b>
[BSW00344] Reference to link-time configuration	Not applicable. (No link time configuration parameters defined for this module).
[BSW00404] Reference to post build time configuration	<a href="#">ADC028</a>
[BSW00405] Reference to multiple configuration sets	<a href="#">ADC054</a> , <a href="#">ADC242</a>
[BSW00345] Pre-compile-time configuration	<a href="#">ADC027</a> , <a href="#">ADC342</a>
[BSW159] Tool-based configuration	Both static and runtime configuration parameters are located outside the source code of the module. This is the prerequisite for automatic configuration.
[BSW167] Static configuration checking	Not applicable. (Requirement on configuration tool).
[BSW171] Configurability of optional functionality	<a href="#">ADC120</a> , <a href="#">ADC121</a> , <a href="#">ADC228</a> , <a href="#">ADC237</a> , <a href="#">ADC259</a> , <a href="#">ADC260</a> , <a href="#">ADC265</a> , <a href="#">ADC266</a>
[BSW170] Data for reconfiguration of AUTOSAR SW-Components	Not applicable. (No reconfiguration and not a SWC)
[BSW00380] Separate C-File for configuration parameters	<a href="#">ADC240</a>
[BSW00419] Separate C-Files for pre-compile time configuration parameters	<a href="#">ADC240</a>
[BSW00381] Separate configuration header file for pre-compile time parameters	<a href="#">ADC267</a>
[BSW00412] Separate H-File for configuration parameters	<a href="#">ADC267</a>
[BSW00383] List dependencies of configuration files	<a href="#">ADC267</a>
[BSW00384] List dependencies to other modules	See chapter 5.
[BSW00387] Specify the configuration class of call-back function	Not applicable. (This module does not provide any callback routines).
[BSW00388] Introduce containers	<a href="#">ADC027</a> , <a href="#">ADC028</a> , <a href="#">ADC242</a> , <a href="#">ADC268</a>
[BSW00389] Containers shall have names	<a href="#">ADC027</a> , <a href="#">ADC028</a> , <a href="#">ADC242</a> , <a href="#">ADC268</a>
[BSW00390] Parameter content shall be unique within the module	<a href="#">ADC027</a> , <a href="#">ADC028</a> , <a href="#">ADC242</a> , <a href="#">ADC268</a>
[BSW00391] Parameter shall have unique names	<a href="#">ADC027</a> , <a href="#">ADC028</a> , <a href="#">ADC242</a> , <a href="#">ADC268</a>
[BSW00392] Parameters shall have a type	<a href="#">ADC027</a> , <a href="#">ADC028</a> , <a href="#">ADC242</a> , <a href="#">ADC268</a>
[BSW00393] Parameters shall have a range	<a href="#">ADC027</a> , <a href="#">ADC028</a> , <a href="#">ADC242</a> , <a href="#">ADC268</a>
[BSW00394] Specify the scope of the parameters	<a href="#">ADC027</a> , <a href="#">ADC028</a> , <a href="#">ADC242</a> , <a href="#">ADC268</a>
[BSW00395] List the required parameters (per parameter)	<a href="#">ADC027</a> , <a href="#">ADC028</a> , <a href="#">ADC242</a> , <a href="#">ADC268</a>
[BSW00396] Configuration classes	<a href="#">ADC027</a> , <a href="#">ADC028</a> , <a href="#">ADC242</a> , <a href="#">ADC268</a>
[BSW00397] Pre-compile-time parameters	<a href="#">ADC027</a> , <a href="#">ADC242</a> , <a href="#">ADC268</a>
[BSW00398] Link-time parameters	Not applicable. (No link time configuration parameters defined for this module).
[BSW00399] Loadable Post-build time parameters	<a href="#">ADC028</a>

<b>Requirements</b>	<b>Satisfied</b>
[BSW00400] Selectable Post-build time parameters	<a href="#">ADC028</a>
[BSW00402] Published information	<a href="#">ADC030</a>
[BSW00375] Notification of wake-up reason	Not applicable. (This module does not provide any wake-up reason).
[BSW101] Initialization interface	<a href="#">ADC054</a>
[BSW00416] Sequence of Initialization	Not applicable. (SW Integration requirement).
[BSW00406] Check module initialization	<a href="#">ADC068</a> , <a href="#">ADC107</a> , <a href="#">ADC154</a> , <a href="#">ADC294</a> , <a href="#">ADC295</a> , <a href="#">ADC297</a> , <a href="#">ADC298</a> , <a href="#">ADC299</a> , <a href="#">ADC300</a> , <a href="#">ADC301</a> , <a href="#">ADC 302</a> , <a href="#">ADC324</a>
[BSW168] Diagnostic Interface of SW components	Not applicable (This module does not support a special diagnostic interface).
[BSW00407] Function to read out published parameters	<a href="#">ADC236</a> , <a href="#">ADC237</a>
[BSW00423] Usage of SW-C template to describe BSW modules with AUTOSAR Interfaces	Not applicable. (driver has no AUTOSAR interfaces).
[BSW00424] BSW main processing function task allocation	Not applicable (This module does not provide a schedulable main function).
[BSW00425] Trigger conditions for schedulable objects	Not applicable. (Requirement on implementation, not on specification).
[BSW00426] Exclusive areas in BSW modules	Not applicable. (Requirement on implementation, not on specification).
[BSW00427] ISR description for BSW modules	Not applicable. (Requirement on implementation, not on specification).
[BSW00428] Execution order dependencies of main processing functions	Not applicable. (Requirement on implementation, not on specification).
[BSW00429] Restricted BSW OS functionality access	Not applicable. (Requirement on implementation, not on specification).
[BSW00431] The BSW Scheduler module implements task bodies	Not applicable. (Requirement on implementation, not on specification).
[BSW00432] Modules should have separate main processing functions for read/receive and write/transmit data path	Not applicable. (This module does not provide a schedulable main function).
[BSW00433] Calling of main processing functions	Not applicable. (This is a general requirement).
[BSW00434] The Schedule Module shall provide an API for exclusive areas	Not applicable. (This is a special requirement for the BSW scheduler).
[BSW00336] Shutdown interface	<a href="#">ADC111</a>
[BSW00337] Classification of errors	<a href="#">ADC065</a> , <a href="#">ADC069</a> , <a href="#">ADC229</a> , <a href="#">ADC230</a>
[BSW00338] Detection and Reporting of development errors	<a href="#">ADC233</a> , <a href="#">ADC234</a> , <a href="#">ADC067</a>
[BSW00369] Do not return development error codes via API	<a href="#">ADC233</a> , <a href="#">ADC234</a> , <a href="#">ADC067</a>
[BSW00339] Reporting of production relevant error and exceptions	<a href="#">ADC068</a> , <a href="#">ADC069</a> , <a href="#">ADC235</a> , <a href="#">ADC239</a>
[BSW00417] Reporting of Error Events by Non-Basic Software	Not applicable. (Module is a BSW).
[BSW00323] API parameter checking	<a href="#">ADC065</a> , <a href="#">ADC125</a> , <a href="#">ADC126</a> ,

<b>Requirements</b>	<b>Satisfied</b>
	<a href="#">ADC128</a> , <a href="#">ADC129</a> , <a href="#">ADC130</a> , <a href="#">ADC131</a> , <a href="#">ADC152</a> , <a href="#">ADC225</a> , <a href="#">ADC241</a> , <a href="#">ADC269</a>
[BSW004] Version check	<a href="#">ADC030</a> , <a href="#">ADC124</a>
[BSW00409] Header files for production code error IDs	<a href="#">ADC239</a>
[BSW00385] List possible error notifications	<a href="#">ADC065</a> , <a href="#">ADC069</a>
[BSW00386] Configuration for detecting an error	<a href="#">ADC068</a> , <a href="#">ADC069</a> , <a href="#">ADC107</a> , <a href="#">ADC112</a> , <a href="#">ADC125</a> , <a href="#">ADC126</a> , <a href="#">ADC128</a> , <a href="#">ADC129</a> , <a href="#">ADC130</a> , <a href="#">ADC131</a> , <a href="#">ADC133</a> , <a href="#">ADC136</a> , <a href="#">ADC137</a> , <a href="#">ADC152</a> , <a href="#">ADC154</a> , <a href="#">ADC164</a> , <a href="#">ADC165</a> , <a href="#">ADC166</a> , <a href="#">ADC225</a> , <a href="#">ADC233</a> , <a href="#">ADC241</a> , <a href="#">ADC269</a> , <a href="#">ADC218</a>
[BSW161] Microcontroller abstraction	Not applicable. (Architectural AUTOSAR concept is the basis for this driver).
[BSW162] ECU layout abstraction	Not applicable. (Architectural AUTOSAR concept is the basis for this driver).
[BSW005] No hard coded horizontal interfaces within MCAL	Not applicable. (Architectural AUTOSAR concept is the basis for this driver).
[BSW00415] User dependent include files	<a href="#">ADC267</a>
[BSW164] Implementation of interrupt service routines	Not applicable. (ADC driver is a part of microcontroller abstraction layer).
[BSW00325] Runtime of interrupt service routines	Not applicable. (Requirement on implementation, not on specification).
[BSW00326] Transition from ISRs to OS tasks	Not applicable. (Requirement on implementation, not on specification).
[BSW00342] Usage of source code and object code	Not applicable. (Requirement on implementation, not on specification).
[BSW00343] Specification and configuration of time	Not applicable. (Requirement on implementation, not on specification).
[BSW160] Human-readable configuration data	Not applicable. (Requirement on implementation, not on specification).
[BSW007] HIS MISRA C	Not applicable. (Requirement on implementation, not on specification).
[BSW00300] Module naming convention	<a href="#">ADC267</a>
[BSW00413] Accessing instances of BSW modules	Not applicable (requirement on implementation, not on specification)
[BSW00347] Naming separation of different instances of BSW drivers	Not applicable. (Requirement on implementation, not on specification).
[BSW00305] Self-defined data types naming convention	Chapter 8.2.
[BSW00307] Global variables naming convention	Not applicable. (Requirement on implementation, not on specification).
[BSW00310] API naming convention	Chapter 8.2.23.
[BSW00373] Main processing function naming convention	Not applicable.

<b>Requirements</b>	<b>Satisfied</b>
	(Requirement on implementation, not on specification).
[BSW00327] Error values naming convention	<a href="#">ADC065</a>
[BSW00335] Status values naming convention	<a href="#">ADC221</a> , <a href="#">ADC222</a> , <a href="#">ADC224</a>
[BSW00350] Development error detection keyword	<a href="#">ADC027</a> , <a href="#">ADC233</a>
[BSW00408] Configuration parameter naming convention	Chapter 10.2.
[BSW00410] Compiler switches shall have defined values	Chapter 10.2.
[BSW00411] Get version info keyword	<a href="#">ADC237</a>
[BSW00346] Basic set of module files	<a href="#">ADC267</a>
[BSW158] Separation of configuration from implementation	<a href="#">ADC027</a> , <a href="#">ADC028</a> , <a href="#">ADC242</a> , <a href="#">ADC267</a>
[BSW00314] Separation of interrupt frames and service routines	<a href="#">ADC267</a>
[BSW00370] Separation of call-back interface from API	<a href="#">ADC267</a> , Chapter 8.4.
[BSW00348] Standard type header	<a href="#">ADC267</a> , Chapter 8.1.1
[BSW00353] Platform specific type header	<a href="#">ADC267</a> , Chapter 8.1.1
[BSW00361] Compiler specific language extension header	<a href="#">ADC267</a>
[BSW00301] Limit imported information	Not applicable. (Requirement on implementation, not on specification).
[BSW00302] Limit exported information	Not applicable. (Requirement on implementation, not on specification).
[BSW00328] Avoid duplication of code	Not applicable. (Requirement on implementation, not on specification).
[BSW00312] Shared code shall be reentrant	Not applicable. (Requirement on implementation, not on specification).
[BSW006] Platform independency	Not applicable. (Requirement on implementation, not on specification).
[BSW00357] Standard API return type	Not applicable. (Type not used in this module).
[BSW00377] Module specific API return types	Chapter 1.1.1.
[BSW00304] AUTOSAR integer data types	Chapter 8.2, Chapter 0.
[BSW00355] Do not redefine AUTOSAR integer data types	Not applicable. (No integer data types redefined in this specification).
[BSW00378] AUTOSAR boolean type	Chapter 10.2.
[BSW00306] Avoid direct use of compiler and platform specific keywords	Not applicable. (Requirement on implementation, not on specification).
[BSW00308] Definition of global data	Not applicable. (Requirement on implementation, not on specification).
[BSW00309] Global data with read-only constraint	Chapter 8.3.1.
[BSW00371] Do not pass function pointers via API	Not applicable. (Requirement on implementation, not on specification).
[BSW00358] Return type of init() functions	Chapter 8.3.1.
[BSW00414] Parameter of init function	Chapter 8.3.1, <a href="#">ADC054</a> , <a href="#">ADC342</a>
[BSW00376] Return type and parameters of main processing functions	Not applicable. (This module does not provide a schedulable main function).
[BSW00359] Return type of call-back functions	<a href="#">ADC082</a>
[BSW00360] Parameters of call-back functions	<a href="#">ADC082</a>
[BSW00329] Avoidance of generic interfaces	Not applicable. (No generic interface in this module).

<b>Requirements</b>	<b>Satisfied</b>
	See chapter 8.2.23).
[BSW00330] Usage of macros / inline functions instead of functions	Not applicable. (Requirement on implementation, not on specification).
[BSW00331] Separation of error and status values	<a href="#">ADC065</a> , <a href="#">ADC269</a>
[BSW009] Module User Documentation	Not applicable. (Requirement for documentation not for module specification).
[BSW00401] Documentation of multiple instances of configuration parameters	Chapter 10.2
[BSW172] Compatibility and documentation of scheduling strategy	Chapter 8.2.23
[BSW010] Memory resource documentation	Not applicable. (Requirement on implementation, not on specification).
[BSW00333] Documentation of call-back function context	Chapter 8.6.3, <a href="#">ADC153</a>
[BSW00374] Module vendor identification	<a href="#">ADC030</a>
[BSW00379] Module identification	<a href="#">ADC030</a>
[BSW003] Version identification	<a href="#">ADC030</a>
[BSW00318] Format of module version numbers	<a href="#">ADC030</a>
[BSW00321] Enumeration of module version numbers	<a href="#">ADC030</a>
[BSW00341] Microcontroller compatibility documentation	Not applicable. (Requirement on implementation, not on specification).
[BSW00334] Provision of XML file	Not applicable. (Requirement on implementation, not on specification).
[BSW00435] Module header file structure for the basic software scheduler	<a href="#">ADC267</a>
[BSW00436] Module header file structure for the basic software memory mapping	<a href="#">ADC267</a>

## Document: General Requirements on SPAL

<b>Requirements</b>	<b>Satisfied by</b>
[BSW12263] Object code compatible configuration concept	<a href="#">ADC028</a> , <a href="#">ADC268</a>
[BSW12056] Configuration of notification mechanisms	<a href="#">ADC080</a> , <a href="#">ADC084</a> , <a href="#">ADC085</a> ,
[BSW12267] Configuration of wake-up sources	Not applicable. (This module does not provide any wake-up reason).
[BSW12057] Driver module initialization	<a href="#">ADC054</a>
[BSW12125] Initialization of hardware resources	<a href="#">ADC056</a>
[BSW12163] Driver module deinitialization	<a href="#">ADC110</a> , <a href="#">ADC111</a>
[BSW12461] Responsibility for register initialization	<a href="#">ADC054</a> , <a href="#">ADC246</a> , <a href="#">ADC247</a> , <a href="#">ADC248</a> , <a href="#">ADC249</a> , <a href="#">ADC250</a>
[BSW12462] Provide settings for register initialization	Chapter 10.2.
[BSW12463] Combine and forward settings for register initialization	Not applicable. (Applies only for configuration tool).
[BSW12068] MCAL initialization sequence	Not applicable. (This is a general software integration requirement).
[BSW12069] Wake-up notification of ECU State Manager	Not applicable. (This module does not provide any wake-up reason).
[BSW157] Notification mechanisms of drivers and handlers	<a href="#">ADC057</a> , <a href="#">ADC058</a> , <a href="#">ADC082</a> , <a href="#">ADC083</a> , <a href="#">ADC104</a>

<b>Requirements</b>	<b>Satisfied by</b>
[BSW12169] Control of operation mode	Not applicable. (The module does not support different modes).
[BSW12063] Raw value mode	<a href="#">ADC113</a>
[BSW12075] Use of application buffers	<a href="#">ADC291</a>
[BSW12129] Resetting of interrupt flags	<a href="#">ADC078</a>
[BSW12064] Change of operation mode during running operation	Not applicable. (The module does not support different modes).
[BSW12448] Behavior after development error detection	<a href="#">ADC065</a> , <a href="#">ADC107</a> , <a href="#">ADC112</a> , <a href="#">ADC125</a> , <a href="#">ADC126</a> , <a href="#">ADC128</a> , <a href="#">ADC129</a> , <a href="#">ADC130</a> , <a href="#">ADC131</a> , <a href="#">ADC133</a> , <a href="#">ADC136</a> , <a href="#">ADC137</a> , <a href="#">ADC152</a> , <a href="#">ADC154</a> , <a href="#">ADC164</a> , <a href="#">ADC165</a> , <a href="#">ADC166</a> , <a href="#">ADC225</a> , <a href="#">ADC241</a> , <a href="#">ADC269</a>
[BSW12067] Setting of wake-up conditions	Not applicable. (This module does not provide any wake-up reason).
<b>Non Functional Requirements</b>	<b>Satisfied by</b>
[BSW12077] Non-blocking implementation	Not applicable. (Requirement on implementation, not on specification).
[BSW12078] Runtime and memory efficiency	Not applicable. (Requirement on implementation, not on specification).
[BSW12092] Access to drivers	Not applicable. (Requirement on implementation, not on specification).
[BSW12265] Configuration data shall be kept constant	Not applicable. (Requirement on implementation, not on specification).
[BSW12264] Specification of configuration items	Chapter 10.2.
<b>Requirements (module specific)</b>	<b>Satisfied by</b>
[BSW12307] ADC channel configuration	<a href="#">ADC011</a> , <a href="#">ADC019</a> , <a href="#">ADC290</a> , <a href="#">ADC023</a> , <a href="#">ADC089</a> , <a href="#">ADC099</a> , <a href="#">ADC268</a> , <a href="#">ADC087</a> , <a href="#">ADC088</a>
[BSW12447] ADC channel group configuration	<a href="#">ADC397</a> , <a href="#">ADC014</a> , <a href="#">ADC399</a> , <a href="#">ADC099</a> , <a href="#">ADC100</a> , <a href="#">ADC101</a> , <a href="#">ADC104</a> , <a href="#">ADC105</a> , <a href="#">ADC287</a> , <a href="#">ADC280</a> , <a href="#">ADC090</a> , <a href="#">ADC291</a> , <a href="#">ADC292</a> , <a href="#">ADC277</a> , <a href="#">ADC098</a> , <a href="#">ADC091</a>
[BSW12817] Configuration of group trigger source	<a href="#">ADC399</a> , <a href="#">ADC146</a> , <a href="#">ADC279</a> , <a href="#">ADC356</a> , <a href="#">ADC357</a> , <a href="#">ADC283</a>
[BSW12818] Assignment of an ADC channel to multiple ADC channle groups	<a href="#">ADC092</a>
[BSW12821] Buffer configuration for stream conversion mode	<a href="#">ADC291</a>
[BSW12820] ADC priority for channel groups	<a href="#">ADC288</a> , <a href="#">ADC289</a> , <a href="#">ADC287</a> , <a href="#">ADC340</a> , <a href="#">ADC341</a> , <a href="#">ADC310</a>
[BSW12280] ADC channel group results access mode	<a href="#">ADC140</a> , <a href="#">ADC382</a> , <a href="#">ADC383</a> , <a href="#">ADC382</a> , <a href="#">ADC383</a> , <a href="#">ADC291</a> , <a href="#">ADC292</a> , <a href="#">ADC317</a>
[BSW12283] Mask out information bits	<a href="#">ADC122</a>
[BSW12819] ADC channel group read service	<a href="#">ADC113</a> , <a href="#">ADC122</a> , <a href="#">ADC141</a> , <a href="#">ADC291</a> , <a href="#">ADC292</a> , <a href="#">ADC318</a>
[BSW12822] ADC uniform result structure	<a href="#">ADC291</a> , <a href="#">ADC320</a>
[BSW12317] ADC channel group notification function	<a href="#">ADC104</a> , <a href="#">ADC155</a> , <a href="#">ADC156</a> ,

<b>Requirements</b>	<b>Satisfied by</b>
	<a href="#">ADC157</a>
[BSW12291] ADC channel group status service	<a href="#">ADC220</a> , <a href="#">ADC221</a> , <a href="#">ADC222</a> , <a href="#">ADC224</a> , <a href="#">ADC226</a> , <a href="#">ADC219</a> , <a href="#">ADC325</a> , <a href="#">ADC326</a> , <a href="#">ADC327</a> , <a href="#">ADC328</a> , <a href="#">ADC329</a> , <a href="#">ADC330</a> , <a href="#">ADC331</a>
[BSW12318] Enable / disable notification functions	<a href="#">ADC057</a> , <a href="#">ADC058</a> , <a href="#">ADC077</a> , <a href="#">ADC156</a> , <a href="#">ADC157</a>
[BSW12364] Start and stop conversion of an ADC channel group	<a href="#">ADC061</a> , <a href="#">ADC385</a> , <a href="#">ADC386</a> , <a href="#">ADC145</a> , <a href="#">ADC146</a> , <a href="#">ADC157</a> , <a href="#">ADC356</a> , <a href="#">ADC357</a> , <a href="#">ADC060</a> ,
[BSW12292] Handling of signed values	<a href="#">ADC113</a> , <a href="#">ADC214</a>
[BSW12288] ADC streaming buffer handling	<a href="#">ADC291</a> , <a href="#">ADC292</a>
[BSW12802] Identify most recent sample and number of available samples	<a href="#">ADC214</a> , <a href="#">ADC215</a> , <a href="#">ADC216</a> , <a href="#">ADC219</a>
[BSW12823] Enable / Disable Hardware Triggers	<a href="#">ADC114</a> , <a href="#">ADC144</a> , <a href="#">ADC273</a> , <a href="#">ADC281</a> , <a href="#">ADC116</a> , <a href="#">ADC282</a>
[BSW12824] Right-aligned results.	<a href="#">ADC113</a>
[BSW12825] Structure of result buffer for streaming conversion mode.	<a href="#">ADC319</a>

*Note: The module specific requirements are synchronized with document 'Requirements on ADC Driver, V2.1.2'.*

## 7 Functional specification

### 7.1 General behavior

#### 7.1.1 Background & Rationale

The table below shows a list of possible desired functionalities of an ADC user and in which way they are provided by the ADC module. Furthermore the table also depicts a possible realization and the mapping of these functionalities to the capabilities of a commercial microcontroller (C16x).

<i>Desired Functionality</i>	<i>ADC Driver Function</i>	<i>Example: C16x Derivate Wording</i>
Just one conversion result of a single channel.	Software triggered one-shot conversion where the converted group consists of exactly one channel.	Fixed channel, single conversion, software trigger.
Cyclic conversion of a single channel.	Hardware triggered one-shot conversion where the converted group consists of exactly one channel.	Fixed channel, single conversion, hardware trigger.
Repeated conversion of a single channel.	Continuous conversion where the converted group consists of exactly one channel.	Fixed channel, continuous conversion.
Just one conversion result of each channel within a group.	Software triggered one-shot conversion where the converted group consists of more than one channel.	Auto scan, single conversion, software trigger.
Cyclic conversion of each channel within a group.	Hardware triggered one-shot conversion where the converted group consists of more than one channel.	Auto scan, single conversion, hardware trigger.
Repeated conversion of each channel within a group.	Continuous conversion where the converted group consists of more than one channel.	Auto scan, continuous conversion.

**Table 2: Different possibilities of One-shot and Continuous conversions**

#### 7.1.2 Requirements

**ADC090:** The ADC module shall allow grouping of one or more ADC channels into so called ADC Channel groups.

**ADC091:** The ADC module's configuration shall be such that an ADC Channel group contains at least one ADC Channel.

**ADC092:** The ADC module shall allow the assignment of an ADC channel to more than one group.

**ADC277:** The ADC module's configuration shall be such that all channels contained in one ADC Channel group shall belong to the same ADC HW Unit.

The ADC module supports the following conversion modes:

- **ADC380:** The ADC module shall support the conversion mode "One-shot Conversion" for all ADC Channel groups. One-shot conversion means that



exactly one conversion is executed for each channel configured for the group being converted.

- **ADC381:** The ADC module shall support the conversion mode “Continuous Conversion<sup>1</sup>” for all ADC Channel groups with trigger source software. “Continuous Conversion” means that after the conversion has been completed, the conversion of the whole group is repeated. The conversions of the individual ADC channels within the group as well as the repetition of the whole group don’t need any additional trigger events to be executed. Converting the individual channels within the group can be done sequentially or in parallel depending on hardware and/or software capabilities.

The ADC module supports the following start conditions or trigger sources:

- **ADC356:** The ADC module shall support the start condition “Software API Call” for all conversion modes. The trigger source “Software API Call” means that the conversion of an ADC Channel group is started/stopped with a service provided by the ADC module.
- **ADC357:** The ADC module shall support the start condition “Hardware Event” for groups configured in One-Shot conversion mode. The trigger source “Hardware Event” means that the conversion of an ADC Channel group can be started by a hardware event, e.g. an expired timer or an edge detected on an input line.

**ADC279:** The ADC module shall allow configuring exactly one trigger source for each ADC Channel group.

The ADC module supports the following result access modes:

- **ADC382:** The ADC module shall support result access using the API function `Adc_GetStreamLastPointer`. Calling `Adc_GetStreamLastPointer` informs the user about the position of the group conversion results of the latest conversion round in the result buffer and about the number of valid conversion results in the result buffer. The result buffer is an external buffer provided from the application.

*Note: The function is used for both types of groups, configured in Streaming Access Mode and in Single Access Mode (Single Access Mode is handled equal to Streaming Access Mode with Streaming Counter equal to 1).*

- **ADC383:** The ADC module shall support result access using the API function `Adc_ReadGroup`, if the generation of this API function is statically configured. Calling `Adc_ReadGroup` copies the group conversion results of the latest conversion round to an application buffer which start address is specified as API parameter of `Adc_ReadGroup`.

*Note: The function is used for both types of groups, configured in Streaming Access Mode and in Single Access Mode.*

---

<sup>1</sup> On some microcontroller also called „auto-scan mode“.

**ADC140:** The ADC module shall guarantee the consistency of the returned result value for each completed conversion.

*Note:*

*The consistency of the group channel results can be obtained with the following methods on the application side:*

- *Using group notification mechanism*
- *Polling via API function `Adc_GetGroupStatus`*

*In any case, new result data must be read out from the result buffer (e.g. via `Adc_ReadGroup`) before they are overwritten. If the function `Adc_GetGroupStatus` reports state `ADC_STREAM_COMPLETED` and conversions for the same group are still ongoing (continuous conversion or hardware triggered conversion), the user is responsible to access the results in the result buffer, before the ADC driver overwrites the group result buffer.*

**ADC384:** The ADC module's environment shall ensure that a conversion has been completed for the requested channel before requesting the conversion result.

*Note: If no conversion has been completed for the requested channel group (e.g. because the conversion of the ADC Channel group has been stopped by the user) the value returned by the ADC module will be arbitrary (`Adc_GetStreamLastPointer` will return 0 and read `NULL_PTR`; `Adc_ReadGroup` will return `E_NOT_OK`).*

**ADC288:** The ADC module shall allow the configuration of a priority level for each channel group.

*Note: This implies a prioritization mechanism, implemented in SW, or where available, supported by the HW. Groups with trigger source HW are prioritized always with the HW prioritization mechanism.*

**ADC310:** The ADC module's priority mechanism shall allow aborting and restarting of channel group conversions.

**ADC345:** The ADC module's priority mechanism shall allow suspending and resuming of channel group conversions.

**ADC430:** The ADC module shall allow a group specific configuration whether the abort/restart or suspend/resume mechanism is used for interrupted channel groups.

*Note: In contrast to the software controlled abort/restart or suspend/resume mechanism on channel group level, the ADC hardware can support abort/restart and suspend/resume mechanism on ADC channel level. It is up to the implementation which of both mechanisms is implemented on channel level.*

**ADC311:** The ADC module's priority mechanism shall allow the queuing of requests for different groups.

*Note: Higher priority groups can abort or suspend lower priority groups. In this case the priority handler should put the interrupted channel group conversion in the queue*

*and this channel group conversion will be restarted or resumed later, transparently to the user.*

**ADC312:** In the ADC module's priority mechanism the lowest priority is 0.

**ADC289:** The ADC module's priority mechanism shall allow the configuration of 256 priority levels (0...255).

**ADC315:** The ADC module shall support the static configuration option to disable the priority mechanism.

**ADC340:** The ADC module shall support the static configuration option to enable the priority mechanism `ADC_PRIORITY_HW_SW`, using both hardware and software prioritization mechanism. If the hardware does not provide the hardware prioritization mechanism a pure software prioritization mechanism shall be implemented.

**ADC341:** If the priority mechanism is supported by the hardware: The ADC module shall support the static configuration option `ADC_PRIORITY_HW` to enable the priority mechanism using only the hardware priority mechanism.

*Note: If hardware priority mechanism is selected, also groups with software trigger source are prioritized from the hardware prioritization mechanism.*

**ADC339:** If hardware priority mechanism is supported and selected: The ADC module shall allow the mapping of the configured priority levels (0-255) to the available hardware priority levels.

*Note: The specific implementation of the ADC module describes restrictions concerning the available hardware priority levels and the possible mapping of the available hardware priorities to the priorities of the ADC channel groups.*

**ADC332:** If the priority mechanism is active, the ADC module shall support a queuing of conversion requests, if channel groups with higher priority interrupt channel groups with lower priority or channel group conversion requests can not immediately be handled, because a higher priority channel group conversion is ongoing.

**ADC417:** If the priority mechanism is active, the ADC module shall handle channel group conversion requests for groups with the same priority level, in a 'first come first served' order.

**ADC333:** If the priority mechanism is not active and if the static configuration parameter `AdcEnableQueuing` is set to ON, the ADC module shall support a queuing of conversion requests and shall service the software groups in a 'first come first served' order.

*Note: Software conversion requests storage shall be supported in a software implemented queue or by the hardware.*

**ADC335:** If the queuing mechanism is active (priority mechanism active or queuing explicitly activated), the ADC module shall store each software conversion request per channel group at most one time in the software queue.

*Note: The ADC module shall only store one conversion request per channel group, not multiple requests, which may occur if a high priority long-term conversion blocks the hardware.*

**ADC336:** 'Enable hardware trigger requests', generated with API function `Adc_EnableHardwareTrigger`, shall not be stored in any queue.

**ADC337:** Hardware triggered conversion request storage shall be supported by the hardware prioritization mechanism.

*Note: The number of hardware triggered requests which can be stored simultaneously, is dependant from the ADC hardware module.*

**ADC338:** The ADC module shall not store software conversion requests for a group, whose group status is not equal to `ADC_IDLE`.

**ADC060:** The ADC module shall call the group notification function, whenever a conversion of all channels of the requested group is completed and if the notification is configured and enabled.

**ADC413:** The ADC module functions shall be reentrant, if the functions are called for different channel groups. This requirement shall be applicable for all API functions, except `Adc_Init`, `Adc_DeInit` and `Adc_GetVersionInfo`.

*Note: The reentrancy of the API functions applies only if the caller takes care that there is no simultaneous usage of the same group.*

**ADC414:** The ADC module's environment shall check the integrity (see Note ADC413) if several calls for the same ADC group are used during runtime in different tasks or ISR's.

**ADC415:** The ADC module shall not check the integrity (see Note ADC413) if several calls for the same ADC group are used during runtime in different tasks or ISRs.



**4. Result access with Adc\_ReadGroup API function**

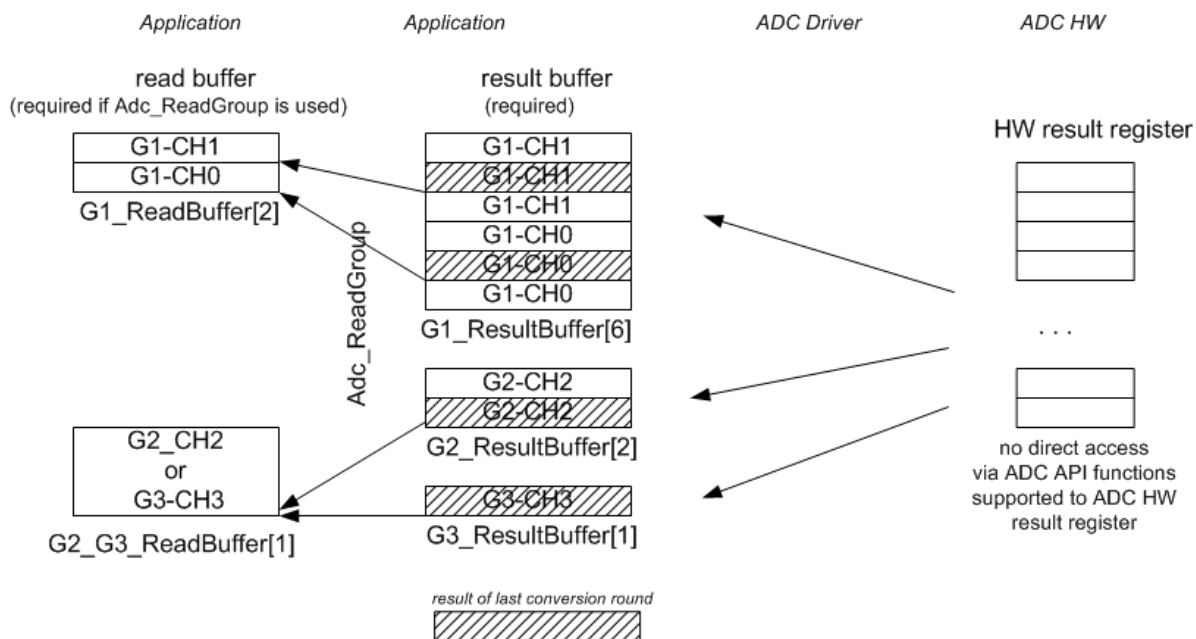

**Figure 3: Example for calling Adc\_ReadGroup which copies results from Result Buffer to optional Read Buffer**

**7.1.3.1 Example: Configuration**

The example configuration consists of three ADC groups. Group 1 consists of 2 channels, group 2 and group 3 consist of one channel each. For group 1 and 2 the group access mode `ADC_ACCESS_MODE_STREAMING` is configured. The group access mode of group 3 is `ADC_ACCESS_MODE_SINGLE`. The ADC driver will store the conversion results of group 1-3 in three application buffers, accessed with three configured `ADC_RESULT_POINTER` : `G1_ResultPtr`, `G2_ResultPtr` and `G3_ResultPtr`.

**7.1.3.2 Example: Initialization**

The user has to provide application result buffers for the ADC group results. One buffer is required for each group. The buffer size depends on the number of group channels, the group access mode and from the number of streaming samples, if streaming access mode is selected. Before starting a group conversion, the user has to initialize the group result pointer using API function `Adc_SetupResultBuffer` which initializes the group result pointer to point to the specified application result buffer.

**7.1.3.3 Example: Adc\_GetStreamLastPointer Usage**

The ADC driver stores the conversion results of group G1, G2 and G3 in the according result buffer `G1_ResultBuffer[]`, `G2_ResultBuffer[]` and `G3_ResultBuffer[]`. A direct access from the ADC API functions to the ADC hardware result register is not supported from the ADC driver.

The user provides three pointers `G1_SamplePtr`, `G2_SamplePtr` and `G3_SamplePtr`

which will point to the ADC application result buffer after calling `Adc_GetStreamLastPointer`. Precisely pointer `G1_SamplePtr` points, after calling `Adc_GetStreamLastPointer`, to the latest `G1_CH0` result of the latest completed conversion round (`G1_CH0` is the first channel in `G1` group definition). The application result buffer layout is shown in Figure 2. The application result buffer of group 1 holds three times the streaming results of `G1_CH0` and then three times the streaming results of `G1_CH1`. Knowing the application result buffer layout, the user is able to access all group channel results of the latest conversion round. `G2_SamplePtr` and `G3_SamplePtr` are also aligned, after calling `Adc_GetStreamLastPointer`, to point to the latest result of the first group channel of the according group. Both groups have only one channel. `G2_SamplePtr` points to one of the `G2_CH2` results (the latest result). Because group 3 is configured in single access mode, `G3_SamplePtr` points always to `G3_CH3`.

`Adc_GetStreamLastPointer` returns the number of valid samples per channel, stored in the application result buffer (number of complete group conversion rounds). If the return value is equal to the configured parameter 'number of streaming samples', all conversion results in the streaming buffer are valid. If the return value is 0, no conversion results are available in the streaming buffer (the sample pointer will be aligned to NULL).

To enable `Adc_GetStreamLastPointer` to align the sample pointer (`G1_SamplePtr`, `G2_SamplePtr` and `G3_SamplePtr`) to point to the latest channel result, the API is defined to pass a pointer to the result pointer instead the result pointer itself.

#### **7.1.3.4 Example: Adc\_ReadGroup Usage**

If the optional API function `Adc_ReadGroup` is enabled, the user has to provide additional buffers for the selected groups, which can hold the results of one group conversion round. Calling `Adc_ReadGroup` copies the latest results from the application result buffer to the application read group buffer. In the example, one application read buffer (`G2_G3_ReadBuffer`) is used for group `G2` and `G3`.

## 7.2 Conversion processing and interaction

### 7.2.1 Background & Rationale

The following examples specify the order of channel conversion depending on group and conversion type:

- **Example 1:** Channel group containing channels [CH0, CH1, CH2, CH3, and CH4] is configured in Continuous conversion mode. After finishing each scan, the notification (if enabled) is called. Then a new scan is started automatically.
- **Example 2:** Channel group containing channels [CH0, CH1, CH2, CH3, and CH4] is configured in One-Shot conversion mode. After finishing the scan the notification (if enabled) is called.
- **Example 3:** Channel group containing channel [CH3] is configured in Continuous conversion mode. After finishing each scan the notification (if enabled) is called. Then a new scan is started automatically.
- **Example 4:** Channel group containing channel [CH4] is configured in One-Shot conversion mode. After finishing the scan the notification (if enabled) is called.

Channel Type	Conversion Type	Process
Multi-channel Group	Continuous	
Multi-channel Group	One-Shot	
Single Channel Group	Continuous	
Single Channel Group	One-Shot	

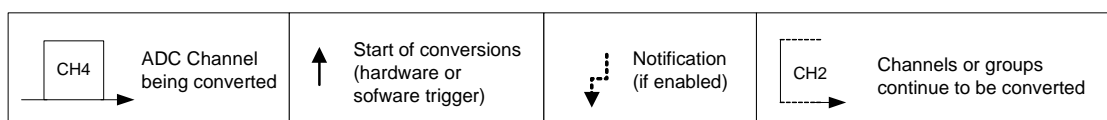

**Figure 4: Conversion Mode behavior examples**



## 7.2.2 Requirements

**ADC280:** The ADC module shall convert only one ADC Channel group per ADC HW Unit at a time. The ADC module shall not support the concurrent conversion of different (even exclusive) ADC Channel groups on the same ADC HW Unit.

*Note: Concurrent conversion of ADC Channel groups on different ADC HW Units may be possible, depending on the capabilities of the hardware. Also concurrent conversion of individual channels within one channel group may be possible if supported by the hardware.*

*Note: If a channel shall be used in different conversion modes (e.g. continuous conversion mode during normal operation and one-shot conversion mode for a special conversion at a dedicated point in time), this channel shall be assigned to different groups configured with the respective conversion modes.*

*Note: In order to request the conversion of a channel shared between two groups, the ADC user has to stop the conversion of the first group containing the specified channel and then start the conversion of the second group containing the specified channel.*

### 7.3 State Diagrams

The ADC module has a state machine that is shown in the following figures. The states are group specific and not module specific. The diagrams show all possible configuration options for ADC groups. The state transitions depend on the ADC group configuration.

#### 7.3.1 ADC State Diagram for One-Shot/Continuous Group Conversion Mode

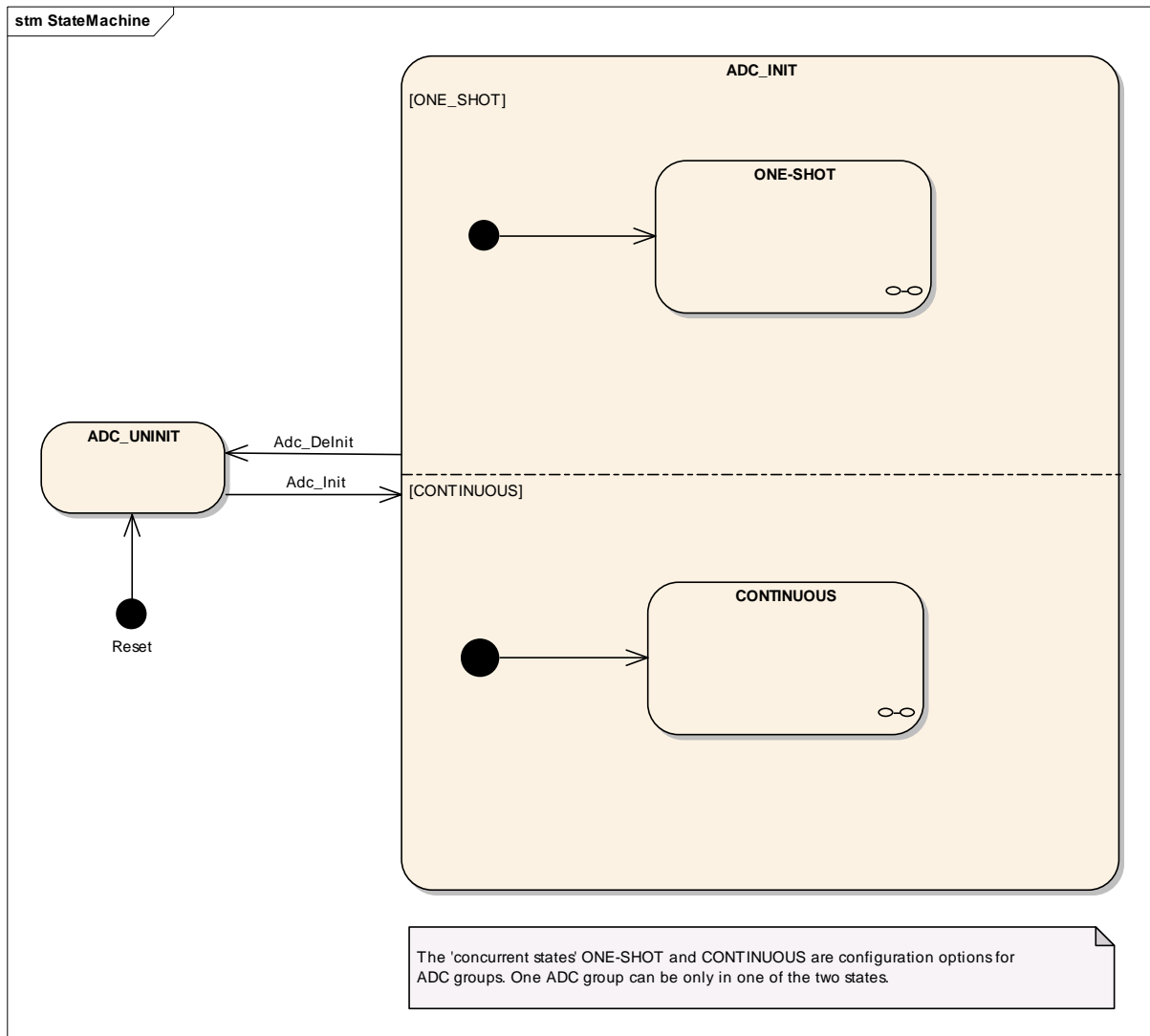

**Figure 5: ADC State Diagram for One-Shot/Continuous Group Conversion Mode**

**7.3.2 ADC State Diagram for HW/SW Trigger in One-Shot Group Conversion Mode**

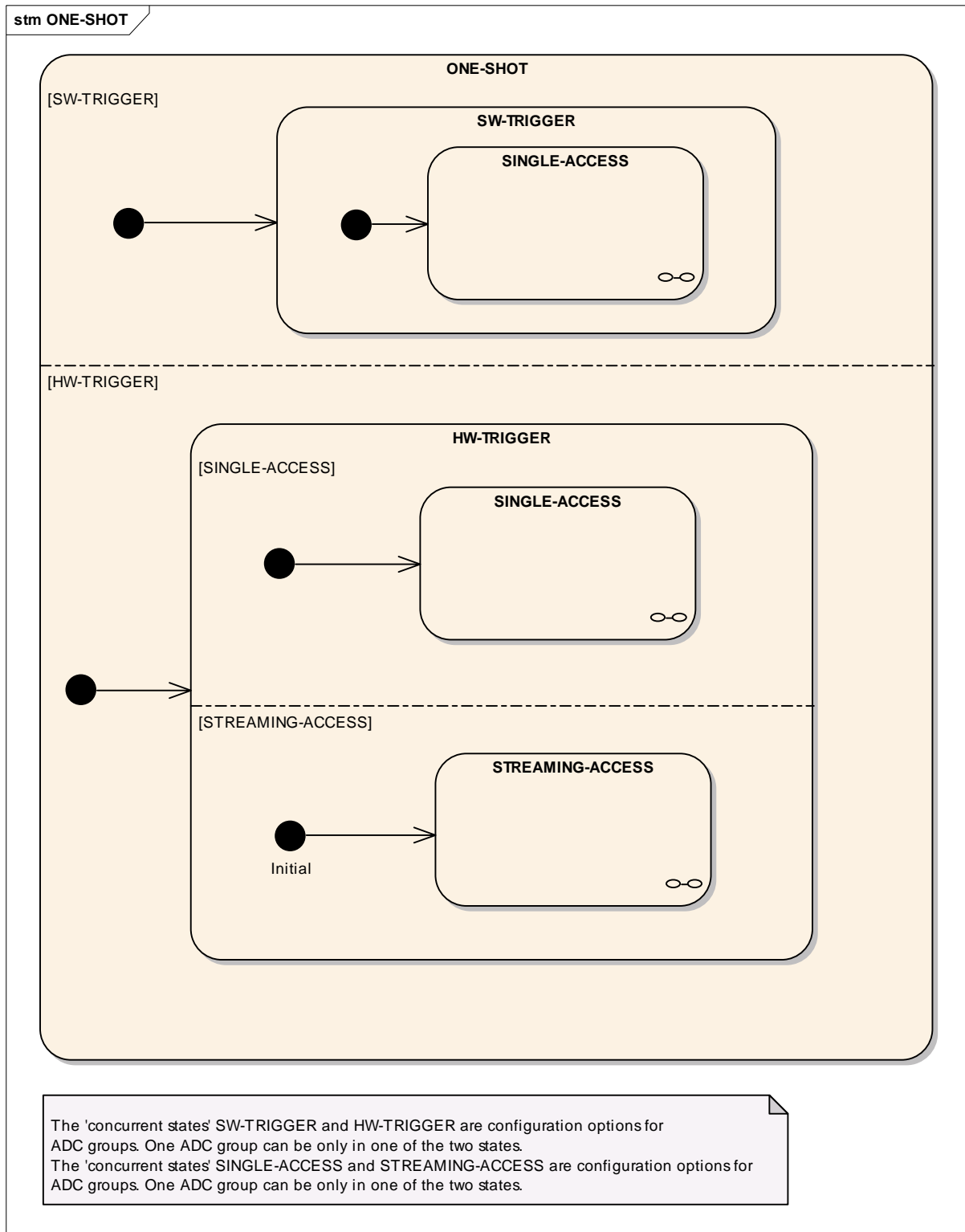

**Figure 6: State Diagram HW/SW Trigger in One-Shot Group Conversion Mode**

**7.3.3 ADC State Diagram for SW Trigger in Continuous Conversion Mode**

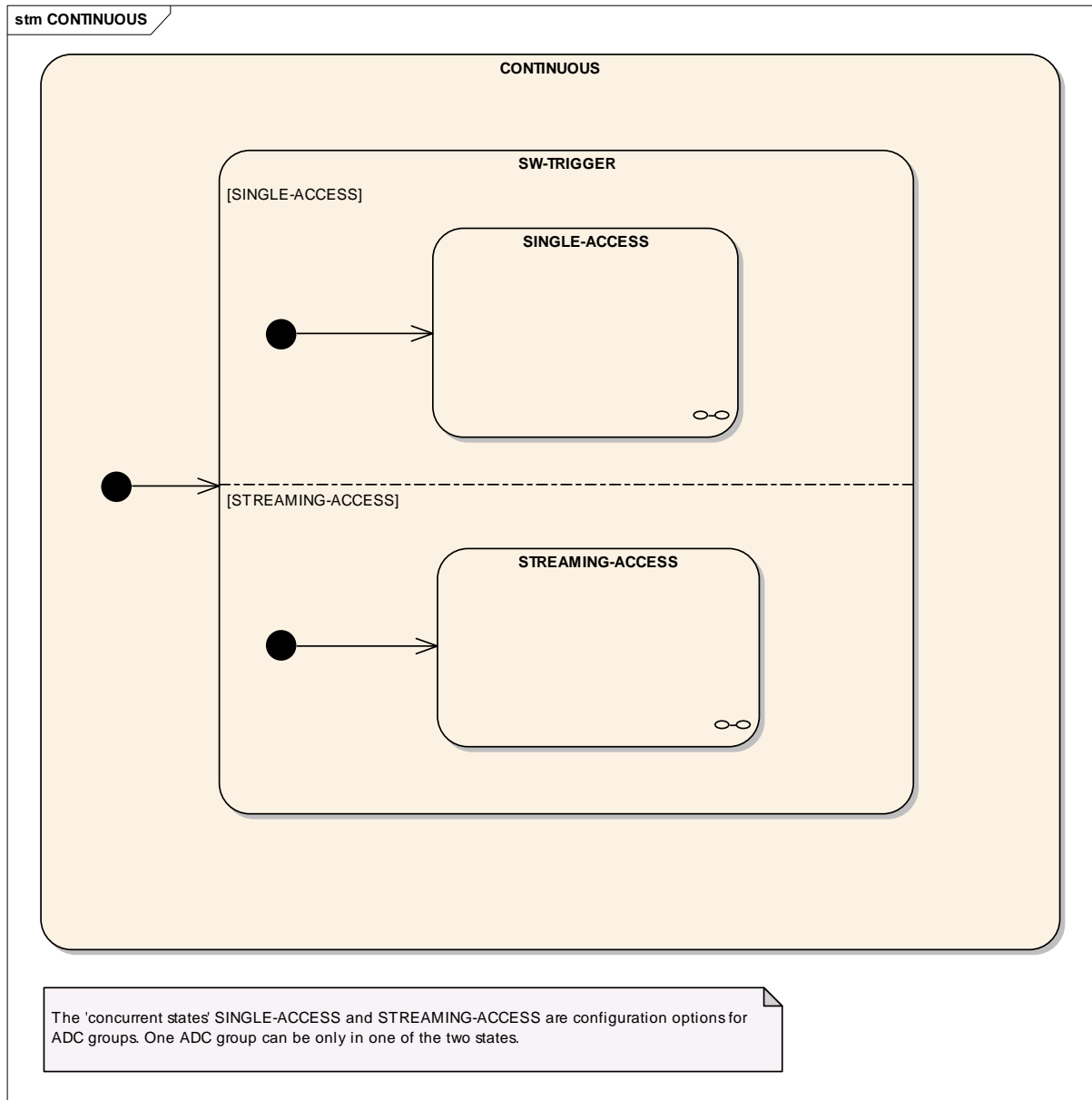

**Figure 7: State Diagram SW Trigger in Continuous Conversion Mode**

**7.3.4 ADC State Diagram for One-Shot Conversion Mode, Software Trigger Source, Single Access Mode**

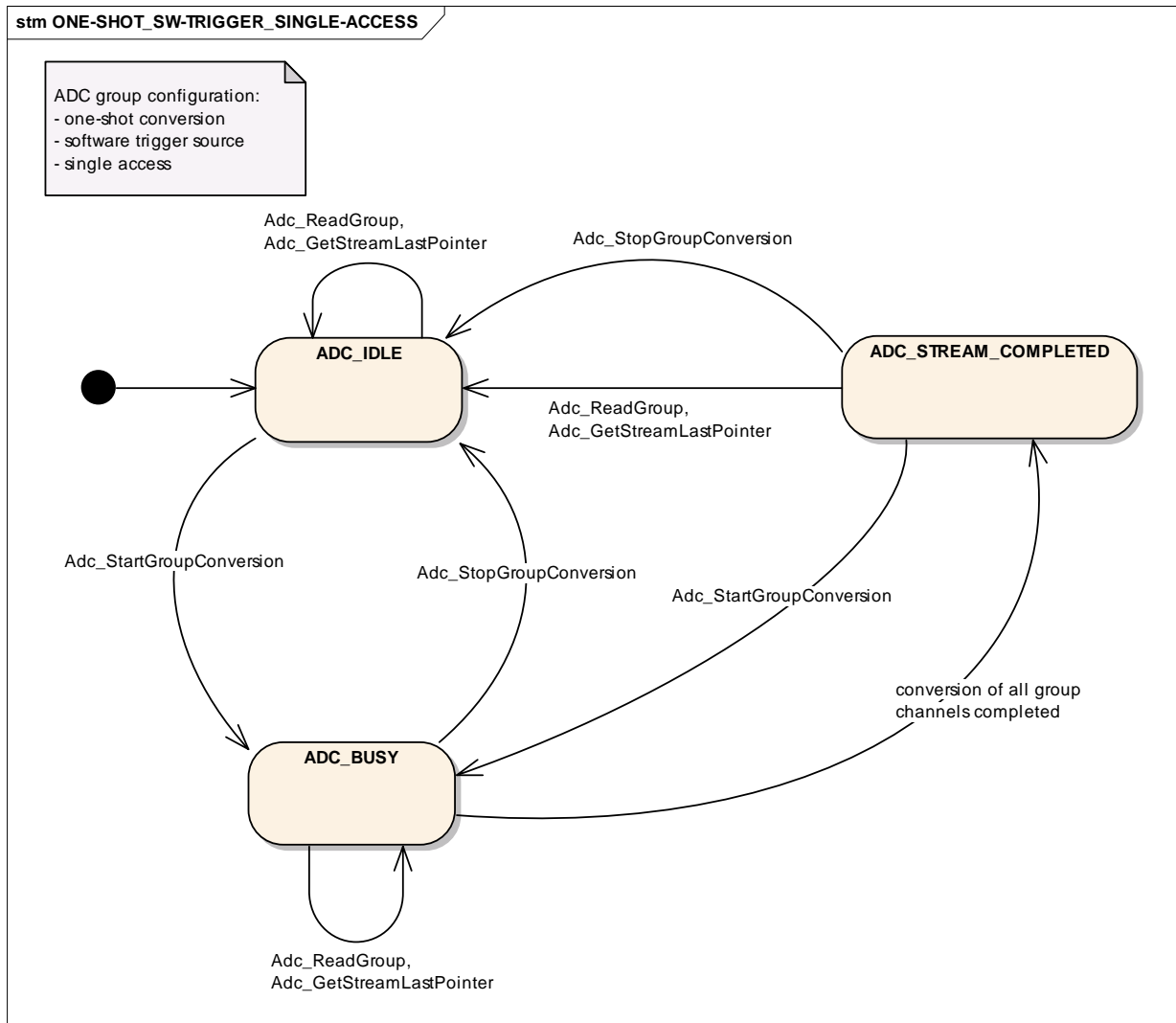

**Figure 8: State Diagram On-Shot, SW Trigger, Single Access**

**7.3.5 ADC State Diagram for One-Shot Conversion, Hardware Trigger Source, Single Access Mode**

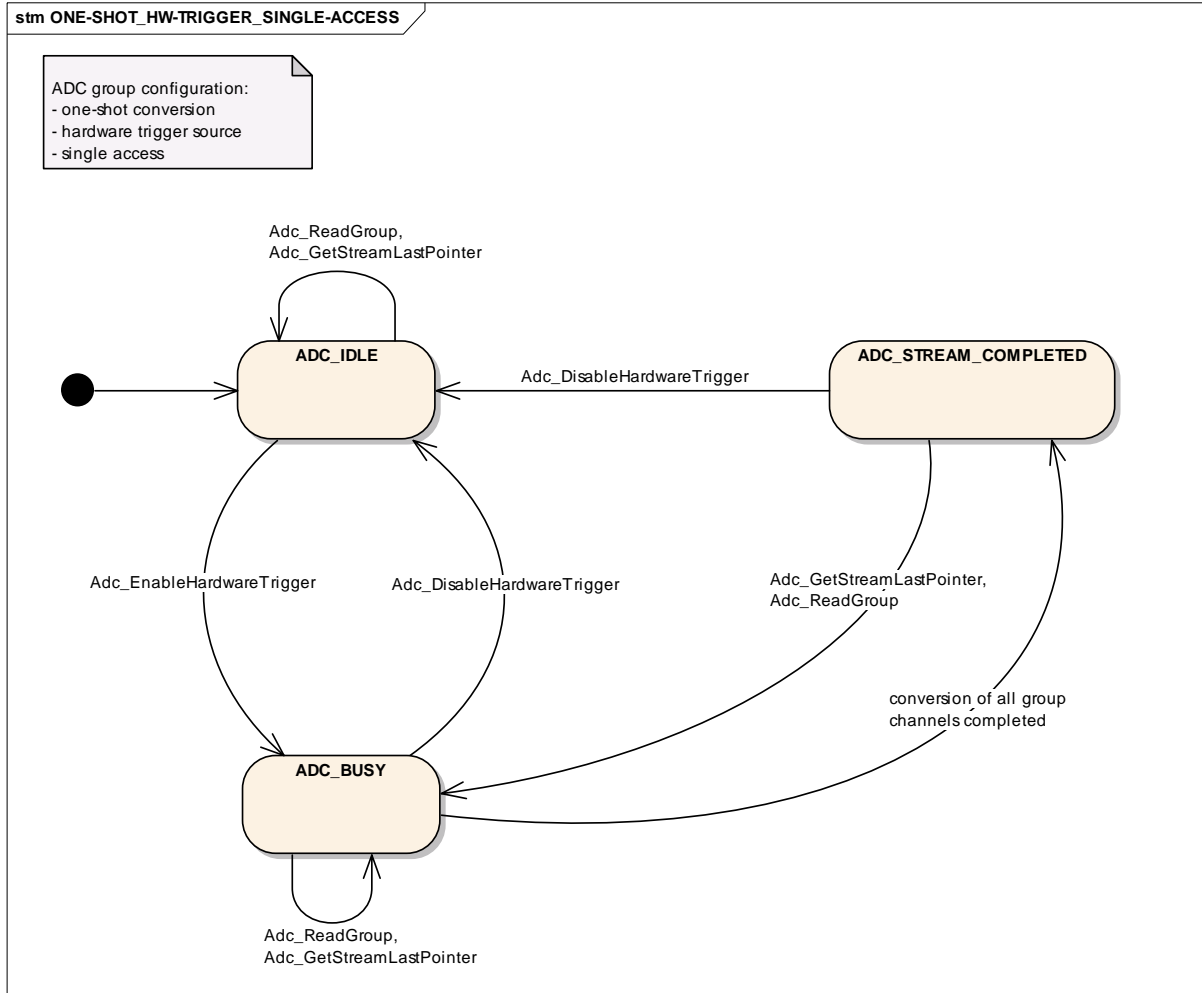

**Figure 9: State Diagram One-Shot, HW Trigger, Single Access**

**7.3.6 ADC State Diagram for One-Shot Conversion Mode, Hardware Trigger Source, Linear and Circular Streaming Access Mode**

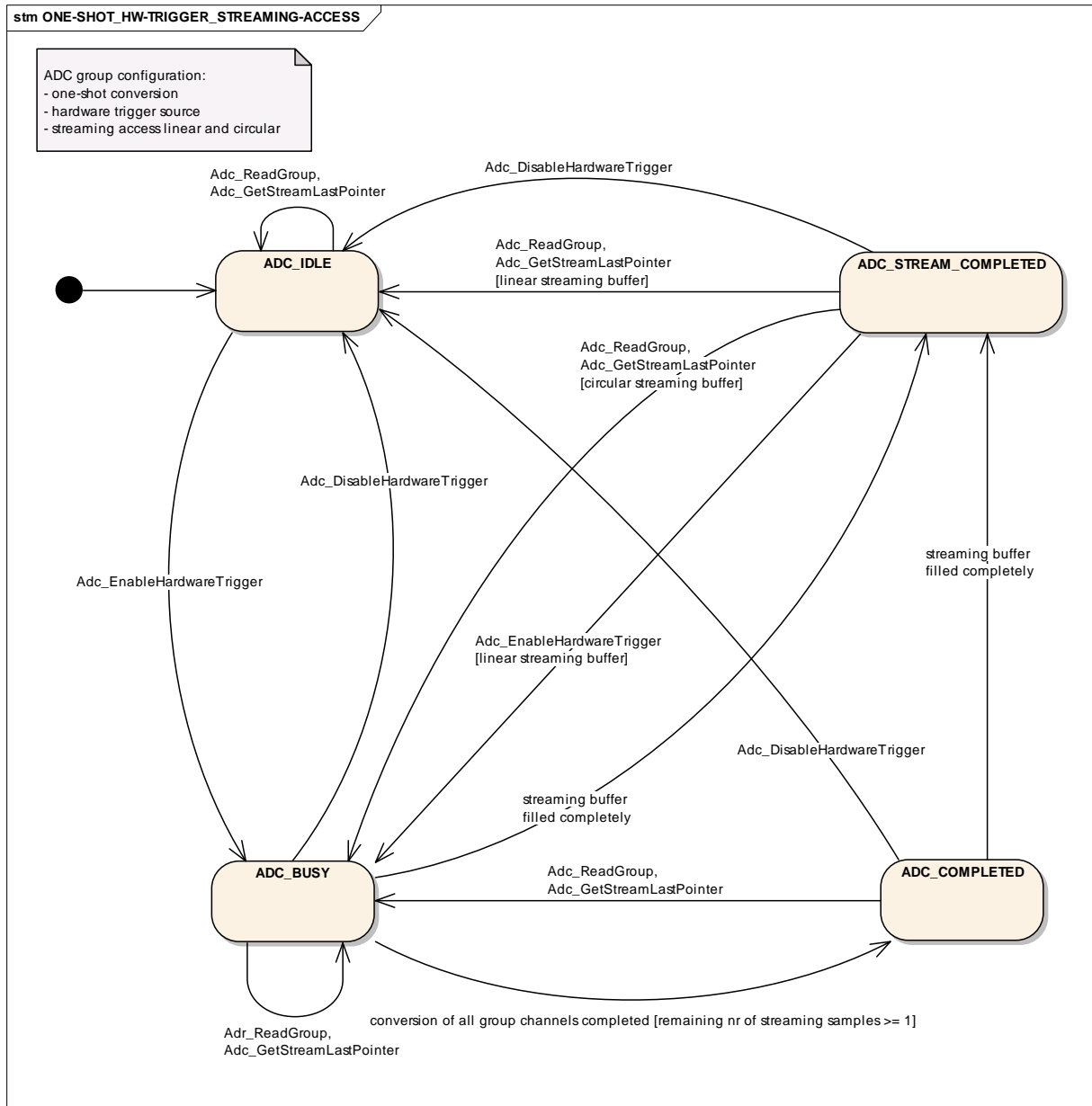

**Figure 10: State Diagram One-Shot, HW Trigger, Streaming Access**

**7.3.7 ADC State Diagram for Continuous Conversion Mode, Software Trigger Source, Single Access Mode**

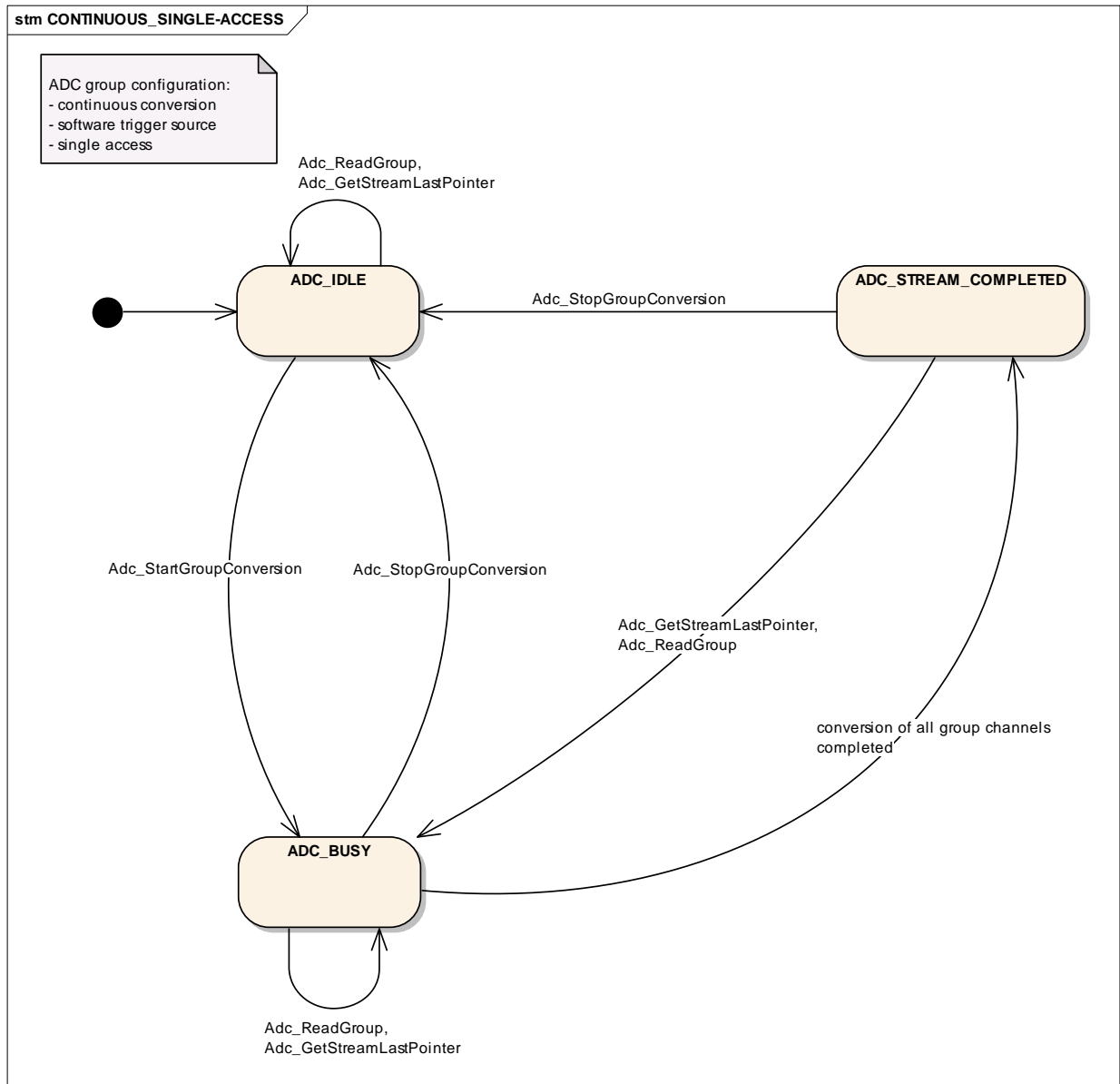

**Figure 11: State Diagram Continuous, SW Trigger, Single Access**



**7.3.8 ADC State Diagram for Continuous Conversion Mode, Software Trigger Source, Linear and Circular Streaming Access Mode**

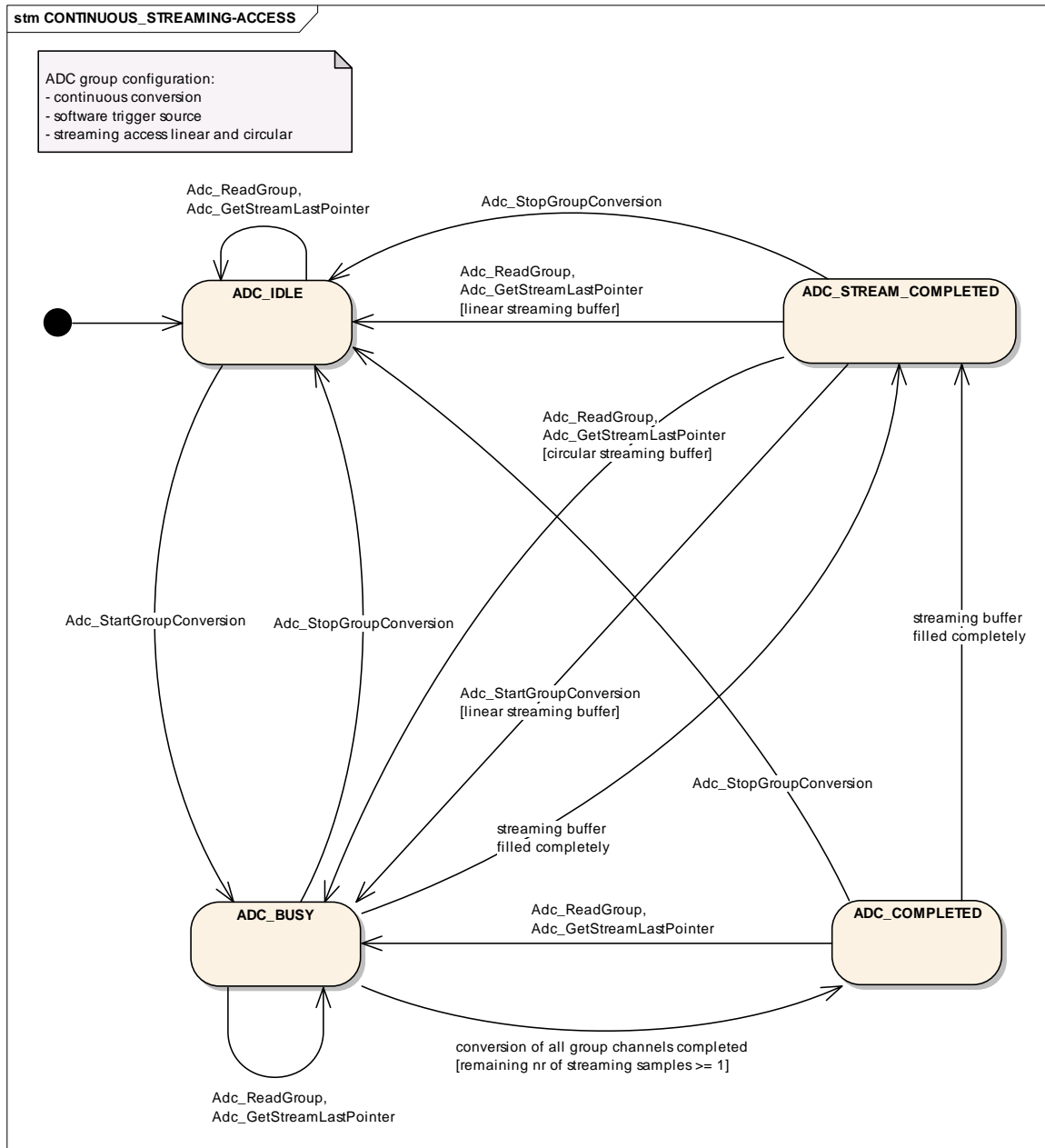

**Figure 12: State Diagram Conversion, SW Trigger, Streaming Access**

## 7.4 Version check

### 7.4.1 Background & Rationale

The integration of incompatible files is to be avoided. Minimum implementation is the version check of the header file inside the .c file (version numbers of .c and .h files must be identical).

### 7.4.2 Requirements

**ADC124:**For included header files

ADC\_AR\_MAJOR\_VERSION  
ADC\_AR\_MINOR\_VERSION  
shall be identical.

For the module internal .c and .h files

ADC\_SW\_MAJOR\_VERSION  
ADC\_SW\_MINOR\_VERSION  
ADC\_AR\_MAJOR\_VERSION  
ADC\_AR\_MINOR\_VERSION  
ADC\_AR\_PATCH\_VERSION  
shall be identical.

## 7.5 Error classification

**ADC230:** Values for production code Event Ids are assigned externally by the configuration of the Dem. They are published in the file Dem\_IntErrId.h and included via Dem.h.

**ADC229:** Development error values are of type uint8.

**ADC065:** The following errors shall be detectable by the ADC module depending on its configuration (development / production mode).

<b>Type of error</b>	<b>Relevance</b>	<b>Related error code</b>	<b>Value [hex]</b>
<p>Adc_Init has not been called prior to another function call (see <a href="#">ADC154</a>, <a href="#">ADC294</a>, <a href="#">ADC295</a>, <a href="#">ADC296</a>, <a href="#">ADC297</a>, <a href="#">ADC298</a>, <a href="#">ADC299</a>, <a href="#">ADC300</a>, <a href="#">ADC301</a>, <a href="#">ADC302</a>, <a href="#">ADC324</a>).</p>	Development	ADC_E_UNINIT	0x0A
<p>Adc_StartGroupConversion was called while another conversion is already running or a HW trigger is already enabled or a request is already stored in the queue (see <a href="#">ADC346</a>, <a href="#">ADC348</a>, <a href="#">ADC350</a>, <a href="#">ADC351</a>, <a href="#">ADC352</a>).</p> <p>Adc_EnableHardwareTrigger was called while a conversion is ongoing or a HW trigger is already enabled or the maximum number of HW triggers is already enabled (see <a href="#">ADC321</a>, <a href="#">ADC349</a>, <a href="#">ADC353</a>).</p> <p>Adc_DeInit was called while a conversion is still ongoing (see <a href="#">ADC112</a>).</p>	Development	ADC_E_BUSY	0x0B
<p>Adc_StopGroupConversion was called while no conversion was running (see <a href="#">ADC241</a>).</p> <p>Adc_DisableHardwareTrigger was called while group is not enabled (see <a href="#">ADC304</a>).</p>	Development	ADC_E_IDLE	0x0C
Adc_Init has been called while ADC is already initialized (see <a href="#">ADC107</a> )	Development	ADC_E_ALREADY_INITIALIZED	0x0D
Adc_Init has been called with incorrect configuration parameter (configuration pointer is NULL_PTR for post-build configuration <a href="#">ADC343</a> or configuration pointer is not equal NULL_PTR for pre-compile configuration <a href="#">ADC344</a> )	Development	ADC_E_PARAM_CONFIG	0x0E
Invalid group ID requested (see <a href="#">ADC125</a> , <a href="#">ADC126</a> , <a href="#">ADC152</a> , <a href="#">ADC128</a> , <a href="#">ADC129</a> , <a href="#">ADC130</a> , <a href="#">ADC131</a> , <a href="#">ADC225</a> , <a href="#">ADC218</a> ).	Development	ADC_E_PARAM_GROUP	0x15
Adc_EnableHardwareTrigger or Adc_DisableHardwareTrigger called on a group with conversion mode configured as continuous (see <a href="#">ADC281</a> , <a href="#">ADC282</a> ).	Development	ADC_E_WRONG_CONV_MODE	0x16
Adc_StartGroupConversion or Adc_StopGroupConversion called on a group with trigger source configured as hardware (see <a href="#">ADC133</a> , <a href="#">ADC164</a> ).	Development	ADC_E_WRONG_TRIGG_SRC	0x17
Adc_EnableHardwareTrigger or Adc_DisableHardwareTrigger called on a group with trigger source configured as software API			

(see <a href="#">ADC136</a> , <a href="#">ADC137</a> ).			
Enable/disable notification function for a group whose configuration set has no notification available (see <a href="#">ADC165</a> , <a href="#">ADC166</a> ).	Development	ADC_E_NOTIF_CAPABILIT Y	0x18
Conversion started and result buffer pointer is not initialized (see <a href="#">ADC424</a> , <a href="#">ADC425</a> ).	Development	ADC_E_BUFFER_UNINIT	0x19
--	Production	--	Assigned by DEM

**Table 3: Error classification**

**ADC069:** Additional errors that are detected because of specific implementation and/or specific hardware properties shall be added in the ADC device specific implementation specification. The classification and enumeration shall be compatible to the errors listed above.

## 7.6 Error detection

**ADC233:** The detection of development errors is configurable (ON/OFF) at pre-compile time. The switch `AdcDevErrorDetect` (see chapter 10.2) shall activate or deactivate the detection of all development errors.

**ADC234:** If the switch `AdcDevErrorDetect` is enabled, API parameter checking is enabled.

*Note: The detailed description of the detected errors can be found in chapter 7.5 and chapter 8.3.*

**ADC235:** The detection of production code errors cannot be switched off.

**ADC269:** If development error detection is enabled for the ADC module, the following API parameter checking shall be performed according to the respective functions (see table below). The error shall be reported to the Development Error Tracer.

*Note: For description and values of the error codes refer to chapter 7.5.*

*Note: For description of boundary conditions for the criteria of the development error detection refer to chapter 8.3.*

<b>Function</b>	<b>Criteria of detection</b>	<b>Related error code</b>
Adc_Init	ADC driver and hardware already initialized.  ADC initialization API called with incorrect configuration pointer	ADC_E_ALREADY_INITIALIZED  ADC_E_PARAM_CONFIG
Adc_DeInit	Function called prior to initialization.  Function called while conversion is running.	ADC_E_UNINIT  ADC_E_BUSY
Adc_StartGroupConversion	Function called prior to initialization.  Function called while any group is not in state ADC_IDLE.  Function called while conversion request already stored in queue.  Function called while conversion of same group is already running.  Function called with non existing group.  Function called for a group configured for hardware trigger source.  Function called while result buffer pointer is not initialized	ADC_E_UNINIT  ADC_E_BUSY    ADC_E_PARAM_GROUP  ADC_E_WRONG_TRIGG_SRC  ADC_E_BUFFER_UNINIT
Adc_StopGroupConversion	Function called prior to initialization.  Function called while group is in state ADC_IDLE.  Function called with non existing group.  Function called for a group configured for hardware trigger source.	ADC_E_UNINIT  ADC_E_IDLE  ADC_E_PARAM_GROUP  ADC_E_WRONG_TRIGG_SRC
Adc_GetGroupStatus	Function called prior to initialization.  Function called with non existing group.	ADC_E_UNINIT  ADC_E_PARAM_GROUP
Adc_ReadGroup	Function called prior to initialization.  Function called with non existing group.  Function called while group status is ADC_IDLE	ADC_E_UNINIT  ADC_E_PARAM_GROUP  ADC_E_IDLE

<p>Adc_EnableHardwareTrigger</p>	<p>Function called prior to initialization.</p> <p>Function called with non existing group.</p> <p>Function called for a group configured for software API trigger source.</p> <p>Function called for a group configured for Continuous conversion mode.</p> <p>Function called while any group is not in state ADC_IDLE.</p> <p>Function called while HW trigger for the group is already enabled.</p> <p>Function called while maximum number of available hardware triggers is already enabled.</p> <p>Function called while result buffer pointer is not initialized</p>	<p>ADC_E_UNINIT</p> <p>ADC_E_PARAM_GROUP</p> <p>ADC_E_WRONG_TRIGG_SRC</p> <p>ADC_E_WRONG_CONV_MODE</p> <p>ADC_E_BUSY</p> <p>ADC_E_BUFFER_UNINIT</p>
<p>Adc_DisableHardwareTrigger</p>	<p>Function called prior to initialization.</p> <p>Function called with non existing group.</p> <p>Function called for a group configured for software API trigger source.</p> <p>Function called for a group configured for Continuous conversion mode.</p> <p>Function called for a non enabled group.</p>	<p>ADC_E_UNINIT</p> <p>ADC_E_PARAM_GROUP</p> <p>ADC_E_WRONG_TRIGG_SRC</p> <p>ADC_E_WRONG_CONV_MODE</p> <p>ADC_E_IDLE</p>
<p>Adc_EnableGroupNotification</p>	<p>Function called prior to initialization.</p> <p>Function called with non existing group.</p> <p>Function called and notification function pointer is NULL.</p>	<p>ADC_E_UNINIT</p> <p>ADC_E_PARAM_GROUP</p> <p>ADC_E_NOTIF_CAPABILITY</p>
<p>Adc_DisableGroupNotification</p>	<p>Function called prior to initialization.</p> <p>Function called with non existing group.</p> <p>Function called and notification function pointer is NULL.</p>	<p>ADC_E_UNINIT</p> <p>ADC_E_PARAM_GROUP</p> <p>ADC_E_NOTIF_CAPABILITY</p>
<p>Adc_GetStreamLastPointer</p>	<p>Function called prior to initialization.</p> <p>Function called with non existing group.</p> <p>Function called while group status is ADC_IDLE</p>	<p>ADC_E_UNINIT</p> <p>ADC_E_PARAM_GROUP</p> <p>ADC_E_IDLE</p>
<p>Adc_GetVersionInfo</p>	<p>Function called prior to initialization.</p>	<p>ADC_E_UNINIT</p>

**Table 4: Error detection**

## 7.7 Error notification

**ADC067:** Detected development errors shall be reported to the *Det\_ReportError* service of the Development Error Tracer (DET) if the pre-processor switch `AdcDevErrorDetect` is set (see chapter 10)

**ADC068:** Production errors shall be reported to the Diagnostic Event Manager (DEM).

## 8 API specification

### 8.1 Imported types

In this chapter all types included from the following files are listed:

#### ADC364:

Header file	Imported Type
Dem_Types.h	Dem_EventIdType
Std_Types.h	Std_ReturnType
	Std_VersionInfoType

### 8.2 Type definitions

#### 8.2.1 Adc\_ConfigType

<b>Name:</b>	Adc_ConfigType	
<b>Type:</b>	Structure	
<b>Range:</b>	--	Implementation specific configuration data structure.
<b>Description:</b>	Data structure containing the set of configuration parameters required for initializing the ADC Driver and ADC HW Unit(s).	

#### 8.2.2 Adc\_ChannelType

<b>Name:</b>	Adc_ChannelType	
<b>Type:</b>	uint8, uint16, uint32	
<b>Range:</b>	--	The range of this type is $\mu$ C specific and has to be described by the supplier.
<b>Description:</b>	Numeric ID of an ADC channel.	

#### 8.2.3 Adc\_GroupType

<b>Name:</b>	Adc_GroupType	
<b>Type:</b>	uint8, uint16, uint32	
<b>Range:</b>	--	The range of this type is $\mu$ C specific and has to be described by the supplier.
<b>Description:</b>	Numeric ID of an ADC channel group.	

#### 8.2.4 Adc\_ValueGroupType

<b>Name:</b>	Adc_ValueGroupType	
<b>Type:</b>	sint8, sint16, sint32, uint8, uint16, uint32	
<b>Range:</b>	--	-- Implementation specific.
<b>Description:</b>	Type for reading the converted values of a channel group (raw, without further scaling, right aligned).	

The result values shall be stored in an integer buffer, i.e. an array of integers.

The following rules shall apply to the driver implementation:



- **ADC318:** In single value access mode the result buffer shall have as many elements as channels belonging to the group. In this way each buffer element corresponds to a channel, in the order the channels are defined in the group.
- **ADC319:** In streaming access mode the result buffer shall have  $m \cdot n$  elements, where  $n$  is the number of channels belonging to the group,  $m$  the number of samples acquired per channel. In this way the first  $m$  elements belong to the first channel in the group, the second  $m$  elements to the second channel and so on.
- **ADC320:** The dimension (in number of bits) of each buffer element (of type integer) shall be uniform, tailored on the largest (in number of bits) channel belonging to any group.

*Note: Only if all ADC channels of all ADC groups have 8 bit resolution, Adc\_ValueGroupType can be configured as 8 bit data type.*

*Note: The information about number of channels belonging to the group and number of samples acquired per channel can be derived from the group configuration data.*

### 8.2.5 Adc\_ClockSourceType

<b>Name:</b>	Adc_ClockSourceType	
<b>Type:</b>	uint8, uint16, uint32	
<b>Range:</b>	--	The range of this type is $\mu$ C specific and has to be described by the supplier.
<b>Description:</b>	Type of clock input for the conversion unit to select different clock sources, if provided by hardware. (This is not an API type).	

### 8.2.6 Adc\_PrescaleType

<b>Name:</b>	Adc_PrescaleType	
<b>Type:</b>	uint8, uint16, uint32	
<b>Range:</b>	--	The range of this type is $\mu$ C specific and has to be described by the supplier.
<b>Description:</b>	Type of clock prescaler factor. (This is not an API type).	

### 8.2.7 Adc\_ConversionTimeType

<b>Name:</b>	Adc_ConversionTimeType	
<b>Type:</b>	uint8, uint16, uint32	
<b>Range:</b>	--	The range of this type is $\mu$ C specific and has to be described by the supplier.
<b>Description:</b>	Type of conversion time, i.e. the time during which the sampled analogue value is converted into digital representation. (This is not an API type).	

### 8.2.8 Adc\_SamplingTimeType

<b>Name:</b>	Adc_SamplingTimeType	
--------------	----------------------	--

<b>Type:</b>	uint8, uint16, uint32	
<b>Range:</b>	--	The range of this type is $\mu$ C specific and has to be described by the supplier.
<b>Description:</b>	Type of sampling time, i.e. the time during which the value is sampled, (in clock-cycles). (This is not an API type).	

## 8.2.9 Adc\_VoltageSourceType

<b>Name:</b>	Adc_VoltageSourceType	
<b>Type:</b>	sint8, sint16, sint32, uint8, uint16, uint32	
<b>Range:</b>	--	The range of this type is $\mu$ C specific and has to be described by the supplier.
<b>Description:</b>	Type of reference voltage source. (This is not an API type).	

## 8.2.10 Adc\_ResolutionType

<b>Name:</b>	Adc_ResolutionType	
<b>Type:</b>	uint8	
<b>Range:</b>	--	The range of this type is $\mu$ C specific and has to be described by the supplier.
<b>Description:</b>	Type of channel resolution in number of bits. (This is not an API type).	

## 8.2.11 Adc\_StatusType

<b>Name:</b>	Adc_StatusType	
<b>Type:</b>	Enumeration	
<b>Range:</b>	ADC_IDLE	- The conversion of the specified group has not been started. - No result is available.
	ADC_BUSY	- The conversion of the specified group has been started and is still going on. - So far no result is available.
	ADC_COMPLETED	- A conversion round (which is not the final one) of the specified group has been finished. - A result is available for all channels of the group.
	ADC_STREAM_COMPLETED	- The result buffer is completely filled - For each channel of the selected group the number of samples to be acquired is available
<b>Description:</b>	Current status of the conversion of the requested ADC Channel group.	

## 8.2.12 Adc\_TriggerSourceType

<b>Name:</b>	Adc_TriggerSourceType	
<b>Type:</b>	Enumeration	
<b>Range:</b>	ADC_TRIGG_SRC_SW	Group is triggered by a software API call.
	ADC_TRIGG_SRC_HW	Group is triggered by a hardware event.
<b>Description:</b>	Type for configuring the trigger source for an ADC Channel group.	

## 8.2.13 Adc\_GroupConvModeType

<b>Name:</b>	Adc_GroupConvModeType	
--------------	-----------------------	--

<b>Type:</b>	Enumeration	
<b>Range:</b>	ADC_CONV_MODE_ONESHOT	Exactly one conversion of each channel in an ADC channel group is performed after the configured trigger event. In case of 'group trigger source software', a started One-Shot conversion can be stopped by a software API call. In case of 'group trigger source hardware', a started One-Shot conversion can be stopped by disabling the trigger event (if supported by hardware).
	ADC_CONV_MODE_CONTINUOUS	Repeated conversions of each ADC channel in an ADC channel group are performed. 'Continuous conversion mode' is only available for 'group trigger source software'. A started 'Continuous conversion' can be stopped by a software API call.
<b>Description:</b>	Type for configuring the conversion mode of an ADC Channel group.	

### 8.2.14 Adc\_GroupPriorityType

<b>Name:</b>	Adc_GroupPriorityType	
<b>Type:</b>	uint8	
<b>Range:</b>	0..255	--
<b>Description:</b>	Priority level of the channel. Lowest priority is 0.	

### 8.2.15 Adc\_GroupDefType

<b>Name:</b>	Adc_GroupDefType	
<b>Type:</b>	Structure	
<b>Range:</b>	Implementation specific.	
<b>Description:</b>	Type of assignment of channels to a channel group (this is not an API type).	

### 8.2.16 Adc\_StreamNumSampleType

<b>Name:</b>	Adc_StreamNumSampleType	
<b>Type:</b>	uint8, uint16, uint32	
<b>Range:</b>	--	The range of this type is $\mu$ C specific and has to be described by the supplier.
<b>Description:</b>	Type for configuring the number of group conversions in streaming access mode (in single access mode, parameter is 1).	

### 8.2.17 Adc\_HwUnitType

<b>Name:</b>	Adc_HwUnitType	
<b>Type:</b>	uint8	
<b>Range:</b>	0..255	--
<b>Description:</b>	Numeric ID of an ADC Hw Unit.	

### 8.2.18 Adc\_StreamBufferModeType

<b>Name:</b>	Adc_StreamBufferModeType	
<b>Type:</b>	Enumeration	
<b>Range:</b>	ADC_STREAM_BUFFER_LINEAR	The ADC Driver stops the conversion as soon as the stream buffer is full (number of samples reached).
	ADC_STREAM_BUFFER_CIRCULAR	The ADC Driver continues the conversion even if

		the stream buffer is full (number of samples reached) by wrapping around the stream buffer itself.
<b>Description:</b>	Type for configuring the streaming access mode buffer type.	

### 8.2.19 Adc\_GroupAccessModeType

<b>Name:</b>	Adc_GroupAccessModeType	
<b>Type:</b>	Enumeration	
<b>Range:</b>	ADC_ACCESS_MODE_SINGLE	Single value access mode.
	ADC_ACCESS_MODE_STREAMING	Streaming access mode.
<b>Description:</b>	Type for configuring the access mode to group conversion results.	

### 8.2.20 Adc\_HwTriggerSignalType

<b>Name:</b>	Adc_HwTriggerSignalType	
<b>Type:</b>	Enumeration	
<b>Range:</b>	ADC_HW_TRIG_RISING_EDGE	React on the rising edge of the hardware trigger signal (only if supported by the ADC hardware).
	ADC_HW_TRIG_FALLING_EDGE	React on the falling edge of the hardware trigger signal (only if supported by the ADC hardware).
	ADC_HW_TRIG_BOTH_EDGES	React on both edges of the hardware trigger signal (only if supported by the ADC hardware).
<b>Description:</b>	Type for configuring on which edge of the hardware trigger signal the driver should react, i.e. start the conversion (only if supported by the ADC hardware).	

### 8.2.21 Adc\_HwTriggerTimerType

<b>Name:</b>	Adc_HwTriggerTimerType	
<b>Type:</b>	uint8, uint16, uint32	
<b>Range:</b>	--	The range of this type is $\mu$ C specific and has to be described by the supplier.
<b>Description:</b>	Type for the reload value of the ADC module embedded timer (only if supported by the ADC hardware).	

### 8.2.22 Adc\_PriorityImplementationType

<b>Name:</b>	Adc_PriorityImplementationType	
<b>Type:</b>	Enumeration	
<b>Range:</b>	ADC_PRIORITY_NONE	priority mechanism is not available
	ADC_PRIORITY_HW	Hardware priority mechanism is available only
	ADC_PRIORITY_HW_SW	Hardware and software priority mechanism is available
<b>Description:</b>	Type for configuring the prioritization mechanism.	

### 8.2.23 Adc\_GroupReplacementType

<b>Name:</b>	Adc_GroupReplacementType	
<b>Type:</b>	Enumeration	
<b>Range:</b>	ADC_GROUP_REPL_ABORT_RESTART	Abort/Restart mechanism is used on group level, if a group is interrupted by a higher priority group. The complete conversion round of the interrupted group (all group channels) is restarted after the higher priority group conversion is finished. If the group is configured in streaming access mode, only the results of the interrupted conversion round are discarded. Results of previous conversion rounds which are already written to the result buffer are not affected.
	ADC_GROUP_REPL_SUSPEND_RESUME	Suspend/Resume mechanism is used on group level, if a group is interrupted by a higher priority group. The conversions round of the interrupted group is completed after the higher priority group conversion is finished.
<b>Description:</b>	Replacement mechanism, which is used on ADC group level, if a group conversion is interrupted by a group which has a higher priority.	

## 8.3 Function definitions

### 8.3.1 Adc\_Init

#### ADC365:

Service name:	Adc_Init		
<b>Syntax:</b>	void	const	Adc_Init ( Adc_ConfigType* ConfigPtr )
<b>Service ID[hex]:</b>	0x00		
<b>Sync/Async:</b>	Synchronous		
<b>Reentrancy:</b>	Non Reentrant		
<b>Parameters (in):</b>	ConfigPtr	Pointer to configuration set in Variant PB (Variant PC requires a NULL_PTR).	
<b>Parameters (inout):</b>	None		
<b>Parameters (out):</b>	None		
<b>Return value:</b>	None		
<b>Description:</b>	Initializes the ADC hardware units and driver.		

**ADC054:** In case of Variant PB: The function Adc\_Init shall initialize the ADC hardware units and driver according to the configuration set referenced by ConfigPtr.

**ADC342:** In case of Variant PC: The function Adc\_Init shall initialize the ADC hardware units and driver according to the pre-compile configuration set. The configuration pointer which is passed to Adc\_Init shall be a NULL pointer. The pointer is only evaluated, if development error detection is enabled (see ADC344).

**ADC056:** The function Adc\_Init shall only initialize the configured resources. Resources that are not contained in the configuration file shall not be touched.

The following rules regarding initialization of controller registers apply to this driver implementation:

- **ADC246:** If the hardware allows for only one usage of the register, the driver module implementing that functionality is responsible for initializing the register.
- **ADC247:** If the register can affect several hardware modules and if it is an I/O register, it shall be initialized by the PORT driver.
- **ADC248:** If the register can affect several hardware modules and if it is not an I/O register, it shall be initialized by the MCU driver.
- **ADC249:** One-time writable registers that require initialization directly after reset shall be initialized by the startup code.
- **ADC250:** All other registers shall be initialized by the startup code.

**ADC077:** The function Adc\_Init shall disable the notifications and hardware trigger capability (if statically configured as active).

**ADC307:** The function `Adc_Init` shall set all groups to `ADC_IDLE` state.

**ADC343:** In case of Variant PB and if development error detection for the ADC module is enabled: if called with a `NULL_PTR` as configuration parameter, the function `Adc_Init` shall raise development error `ADC_E_PARAM_CONFIG` and return without any action.

**ADC344:** In case of Variant PC and if development error detection for the ADC module is enabled: if called without a `NULL_PTR` as configuration parameter, the function `Adc_Init` shall raise development error `ADC_E_PARAM_CONFIG` and return without any action.

**ADC107:** If development error detection for the ADC module is enabled: if called when the ADC driver and hardware are already initialized, the function `Adc_Init` shall raise development error `ADC_E_ALREADY_INITIALIZED` and return without any action.





### 8.3.3 Adc\_Delnit

#### ADC366:

Service name:	Adc_Delnit
<b>Syntax:</b>	void Adc_DeInit ( )
<b>Service ID[hex]:</b>	0x01
<b>Sync/Async:</b>	Synchronous
<b>Reentrancy:</b>	Non Reentrant
<b>Parameters (in):</b>	None
<b>Parameters (inout):</b>	None
<b>Parameters (out):</b>	None
<b>Return value:</b>	None
<b>Description:</b>	Returns all ADC HW Units to a state comparable to their power on reset state.

**ADC110:** The function Adc\_Delnit shall return all ADC HW Units to a state comparable to their power on reset state. Values of registers which are not writeable are excluded. It's the responsibility of the hardware design that this state does not lead to undefined activities in the  $\mu$ C.

**ADC111:** The function Adc\_Delnit shall disable all used interrupts and notifications.

**ADC358:** The ADC module's environment shall not call the function Adc\_Delnit while any group is not in state ADC\_IDLE.

**ADC228:** The function Adc\_Delnit shall be pre compile time configurable On/Off by the configuration parameter: AdcDelnitApi.

**ADC112:** If development error detection for the ADC module is enabled: if called while not all groups are either in state ADC\_IDLE or state ADC\_STREAM\_COMPLETED, while no conversion is ongoing (ADC groups which are implicitly stopped), the function Adc\_Delnit shall raise development error ADC\_E\_BUSY and return without any action.

**ADC154:** If development error detection for the ADC module is enabled: if called before the module has been initialized, the function Adc\_Delnit shall raise development error ADC\_E\_UNINIT and return without any action.

### 8.3.4 Adc\_StartGroupConversion

#### ADC367:

Service name:	Adc_StartGroupConversion
<b>Syntax:</b>	void Adc_StartGroupConversion( Adc_GroupType Group )
<b>Service ID[hex]:</b>	0x02
<b>Sync/Async:</b>	Asynchronous
<b>Reentrancy:</b>	Reentrant
<b>Parameters (in):</b>	Group Numeric ID of requested ADC Channel group.
<b>Parameters (inout):</b>	None
<b>Parameters (out):</b>	None
<b>Return value:</b>	None
<b>Description:</b>	Starts the conversion of all channels of the requested ADC Channel group.

**ADC061:** The function Adc\_StartGroupConversion shall start the conversion of all channels of the requested ADC Channel group. Depending on the group configuration, one-shot or continuous conversion is started.

**ADC431:** The function Adc\_StartGroupConversion shall reset the internal result buffer pointer, that conversion result storage always starts, after calling Adc\_StartGroupConversion, at the result buffer base address which was configured with Adc\_SetupResultBuffer.

**ADC156:** The function Adc\_StartGroupConversion shall NOT automatically enable the notification mechanism for that group (this has to be done by a separate API call).

**ADC146:** The ADC module's environment shall only call Adc\_StartGroupConversion for groups configured with software trigger source.

**ADC259:** The function Adc\_StartGroupConversion shall be pre-compile time configurable On/Off by the configuration parameter AdcEnableStartStopGroupApi.

**ADC125:** If development error detection for the ADC module is enabled: when called with a non-existing channel group ID, function Adc\_StartGroupConversion shall raise development error ADC\_E\_PARAM\_GROUP and return without any action.

**ADC133:** If development error detection for the ADC module is enabled: when called on a group with trigger source configured as hardware, function Adc\_StartGroupConversion shall raise development error ADC\_E\_WRONG\_TRIGG\_SRC and return without any action.

**ADC346:** If development error detection for the ADC module is enabled and the priority mechanism is disabled and the queuing is disabled : when called while any of the groups, which can not be implicitly stopped, is not in state ADC\_IDLE , the function Adc\_StartGroupConversion shall raise development error ADC\_E\_BUSY and return without any action.

*Note: The condition that any group is not in state ADC\_IDLE means in this context:*

- Any conversion is ongoing  
or
- Any HW trigger is enabled

**ADC426:** If development error detection for the ADC module is enabled and the priority mechanism is disabled and the queuing is disabled: when called while any of the groups, which can be implicitly stopped, is not in state ADC\_IDLE and not in state ADC\_STREAM\_COMPLETED, the function Adc\_StartGroupConversion shall raise development error ADC\_E\_BUSY and return without any action.

*Note: Groups which can be implicitly stopped are:*

- Software triggered groups configured in one-shot, single-access mode
- Software triggered groups configured in continuous, linear streaming access mode
- Hardware triggered groups configured in one-shot, linear streaming access mode

**ADC348:** If development error detection for the ADC module is enabled and the priority mechanism is enabled: when called while a group, which can not be implicitly stopped, is not in state ADC\_IDLE, the function Adc\_StartGroupConversion shall raise development error ADC\_E\_BUSY and return without any action.

*Note: The condition that the group is not in state ADC\_IDLE means in this context:*

- The conversion of the same group is currently ongoing  
or
- A conversion request for the same group is already stored one time in the queue

**ADC427:** If development error detection for the ADC module is enabled and the priority mechanism is enabled: when called while a group, which can be implicitly stopped, is not in state ADC\_IDLE and not in state ADC\_STREAM\_COMPLETED, the function Adc\_StartGroupConversion shall raise development error ADC\_E\_BUSY and return without any action.

**ADC351:** If development error detection for the ADC module is enabled and the priority mechanism is disabled and the queuing is enabled: when called while a group, which can not be implicitly stopped, is not in state ADC\_IDLE, the function Adc\_StartGroupConversion shall raise development error ADC\_E\_BUSY and return without any action.

**ADC428:** If development error detection for the ADC module is enabled and the priority mechanism is disabled and the queuing is enabled: when called while a group, which can be implicitly stopped, is not in state `ADC_IDLE` and not in state `ADC_STREAM_COMPLETED`, the function `Adc_StartGroupConversion` shall raise development error `ADC_E_BUSY` and return without any action.

**ADC294:** If development error detection for the ADC module is enabled: when called prior to initializing the driver, the function `Adc_StartGroupConversion` shall raise development error `ADC_E_UNINIT`.

**ADC424:** If development error detection for the ADC module is enabled: when called prior to initializing the result buffer pointer with function `Adc_SetupResultBuffer`, the function `Adc_StartGroupConversion` shall raise development error `ADC_E_BUFFER_UNINIT`.

### 8.3.5 Adc\_StopGroupConversion

#### ADC368:

Service name:	Adc_StopGroupConversion
<b>Syntax:</b>	void Adc_StopGroupConversion( Adc_GroupType Group )
<b>Service ID[hex]:</b>	0x03
<b>Sync/Async:</b>	Synchronous
<b>Reentrancy:</b>	Reentrant
<b>Parameters (in):</b>	Group Numeric ID of requested ADC Channel group.
<b>Parameters (inout):</b>	None
<b>Parameters (out):</b>	None
<b>Return value:</b>	None
<b>Description:</b>	Stops the conversion of the requested ADC Channel group.

**ADC385:** When the ADC Channel Group is in one-shot and software-trigger mode, the function Adc\_StopGroupConversion shall stop an ongoing conversion of the group and remove any start/restart requests of the group from the queue, if queuing is enabled.

**ADC386:** When the ADC Channel Group is in continuous-conversion and software-trigger mode, the function Adc\_StopGroupConversion shall stop an ongoing conversion of the group and remove any start/restart requests of the group from the queue, if queuing is enabled.

**ADC155:** The function Adc\_StopGroupConversion shall automatically disable group notification for the requested group.

*Note:*

*Groups which are implicitly stopped shall not disable the group notification until Adc\_StopGroupConversion is called.*

**ADC360:** The function Adc\_StopGroupConversion shall set the group status to state ADC\_IDLE.

**ADC283:** The ADC module's environment shall only call the function Adc\_StopGroupConversion for groups configured with trigger source software.

**ADC260:** The function Adc\_StopGroupConversion shall be pre compile time configurable On/Off by the configuration parameter AdcEnableStartStopGroupApi.

**ADC126:** If development error detection for the ADC module is enabled: if the group ID is non-existing, the function `Adc_StopGroupConversion` shall raise development error `ADC_E_PARAM_GROUP` and return without any action.

**ADC164:** If development error detection for the ADC module is enabled: if the group has a trigger source configured as hardware, function `Adc_StopGroupConversion` shall raise development error `ADC_E_WRONG_TRIGG_SRC` and return without any action.

**ADC241:** If development error detection for the ADC module is enabled: when called while the group is in state `ADC_IDLE`, the function `Adc_StopGroupConversion` shall raise development error `ADC_E_IDLE` and return without any action.

*Note: For groups which are implicitly stopped (groups with conversion mode one-shot or groups with linear streaming buffer mode), state is `ADC_STREAM_COMPLETED` until results are accessed with `Adc_ReadGroup` or `Adc_GetStreamLastPointer` API functions or until group is explicitly stopped by `Adc_StopGroupConversion` API.*

**ADC295:** If development error detection for the ADC module is enabled: if called prior to initializing the module, function `Adc_StopGroupConversion` shall raise development error `ADC_E_UNINIT` and return without any action.

*Note:*

*All groups which are started with `Adc_StartGroupConversion` should also be stopped with `Adc_StopGroupConversion`, before they are started again to reset the group status to `ADC_IDLE`. Exceptions to this rule are groups which are implicitly stopped because of the selected conversion mode (linear buffer with streaming access mode or one-shot conversion mode with single access). These groups can also be restarted while the group is in state `ADC_STREAM_COMPLETED`.*



**ADC359:** The function `Adc_ReadGroup` shall be pre-compile configurable On/Off by the configuration parameter `AdcReadGroupApi`.

**ADC388:** If development error detection for the ADC module is enabled: when called while the group status is `ADC_IDLE` and the group conversion was not started (no results are available from previous conversions), the function `Adc_ReadGroup` shall raise development error `ADC_E_IDLE`, return `E_NOT_OK` and return without any action.

**ADC152:** If development error detection for the ADC module is enabled: if the group ID is non-existing, the function `Adc_ReadGroup` shall raise development error `ADC_E_PARAM_GROUP` and return `E_NOT_OK`.

**ADC296:** If development error detection for the ADC module is enabled: when called prior to initializing the driver, the function `Adc_ReadGroup` shall raise development error `ADC_E_UNINIT` and return `E_NOT_OK`.



### 8.3.7 Adc\_EnableHardwareTrigger

#### ADC370:

Service name:	Adc_EnableHardwareTrigger
<b>Syntax:</b>	void Adc_EnableHardwareTrigger( Adc_GroupType Group )
<b>Service ID[hex]:</b>	0x05
<b>Sync/Async:</b>	Synchronous
<b>Reentrancy:</b>	Reentrant
<b>Parameters (in):</b>	Group   Numeric ID of requested ADC Channel group.
<b>Parameters (inout):</b>	None
<b>Parameters (out):</b>	None
<b>Return value:</b>	None
<b>Description:</b>	Enables the hardware trigger for the requested ADC Channel group.

**ADC114:** The function Adc\_EnableHardwareTrigger shall enable the hardware trigger for the requested ADC Channel group.

*Note: Adc\_EnableHardwareTrigger can only be used for ADC internal trigger sources controlled from the ADC hardware.*

**ADC144:** A group with trigger source hardware, whose trigger was enabled with Adc\_EnableHardwareTrigger, shall execute the group channel conversions, whenever a trigger event occurs.

**ADC432:** The function Adc\_EnableHardwareTrigger shall reset the internal group result buffer pointer, that conversion result storage always starts, after calling Adc\_EnableHardwareTrigger, at the result buffer base address which was configured with Adc\_SetupResultBuffer.

**ADC273:** The ADC module's environment shall guarantee that no concurrent conversions take place on the same HW Unit (happening of different hardware triggers at the same time).

*Note: The reason for ADC273 is that the ADC module can only handle one group conversion request per HW Unit at the same time. In case of concurrent HW conversion requests, the HW prioritization mechanism controls the conversion order.*

**ADC120:** The ADC module's environment shall only call the function Adc\_EnableHardwareTrigger for groups configured in hardware trigger mode (see AdcGroupTriggSrc).

**ADC265:** The function Adc\_EnableHardwareTrigger shall be pre-compile time configurable On/Off by the configuration parameter AdcHwTriggerApi.

**ADC321:** If development error detection is enabled for the ADC driver and if the priority mechanism is disabled and queuing disabled: when called while any group with trigger source SW is not in state ADC\_IDLE, the function Adc\_EnableHardwareTrigger shall raise development error ADC\_E\_BUSY and return without any action.

**ADC349:** If development error detection for the ADC module is enabled: if the HW trigger for the group is already enabled, the function `Adc_EnableHardwareTrigger` shall raise development error `ADC_E_BUSY` and return without any action.

**ADC353:** If development error detection for the ADC module is enabled: if the maximum number of available hardware triggers is already enabled (device and implementation specific), the function `Adc_EnableHardwareTrigger` shall raise development error `ADC_E_BUSY` and return without any action.

**ADC128:** If development error detection for the ADC module is enabled: if the channel group ID is invalid, the function `Adc_EnableHardwareTrigger` shall raise development error `ADC_E_PARAM_GROUP` and return without any action.

**ADC136:** If development error detection for the ADC module is enabled: if the group is configured for software API trigger mode, the function `Adc_EnableHardwareTrigger` shall raise development error `ADC_E_WRONG_TRIGG_SRC` and return without any action.

**ADC281:** If development error detection for the ADC module is enabled: if a HW group is erroneously configured for continuous conversion mode, the function `Adc_EnableHardwareTrigger` shall raise development error `ADC_E_WRONG_CONV_MODE` and return without any action.

*Note: SW groups configured in continuous conversion mode shall raise development error `ADC_E_WRONG_TRIGG_SRC` instead.*

**ADC297:** If development error detection for the ADC module is enabled: if called prior to initializing the driver, the function `Adc_EnableHardwareTrigger` shall raise development error `ADC_E_UNINIT` and return without any action.

**ADC425:** If development error detection for the ADC module is enabled: when called prior to initializing the result buffer pointer with function `Adc_SetupResultBuffer`, the function `Adc_EnableHardwareTrigger` shall raise development error `ADC_E_BUFFER_UNINIT`.

### 8.3.8 Adc\_DisableHardwareTrigger

#### ADC371:

Service name:	Adc_DisableHardwareTrigger
<b>Syntax:</b>	void Adc_DisableHardwareTrigger ( Adc_GroupType Group )
<b>Service ID[hex]:</b>	0x06
<b>Sync/Async:</b>	Synchronous
<b>Reentrancy:</b>	Reentrant
<b>Parameters (in):</b>	Group Numeric ID of requested ADC Channel group.
<b>Parameters (inout):</b>	None
<b>Parameters (out):</b>	None
<b>Return value:</b>	None
<b>Description:</b>	Disables the hardware trigger for the requested ADC Channel group.

**ADC116:** The function Adc\_DisableHardwareTrigger shall disable the hardware trigger for the requested ADC Channel group.

**ADC429:** The function Adc\_DisableHardwareTrigger shall remove any queued start/restart request for the requested ADC Channel group if queuing is enabled.

**ADC145:** The function Adc\_DisableHardwareTrigger shall abort an ongoing conversion, if applicable (supported by the hardware).

**ADC157:** If enabled, the function Adc\_DisableHardwareTrigger shall disable the notification mechanism for the requested group.

**ADC361:** The function Adc\_DisableHardwareTrigger shall set the group status to state ADC\_IDLE.

**ADC121:** The ADC module's environment shall only call the function Adc\_DisableHardwareTrigger for groups configured in hardware trigger mode (see AdcGroupTriggSrc).

**ADC266:** The function Adc\_DisableHardwareTrigger shall be pre-compile time configurable On/Off by the configuration parameter AdcHwTriggerApi.

**ADC129:** If development error detection for the ADC module is enabled: if the channel group ID is non-existing, the function Adc\_DisableHardwareTrigger shall raise development error ADC\_E\_PARAM\_GROUP and return without any action

**ADC137:** If development error detection for the ADC module is enabled: if the group is configured for software API trigger mode, the function Adc\_DisableHardwareTrigger shall raise development error ADC\_E\_WRONG\_TRIGG\_SRC and return without any action.

**ADC282:** If development error detection for the ADC module is enabled: if a HW group is erroneously configured for continuous conversion mode, the function `Adc_DisableHardwareTrigger` shall raise development error `ADC_E_WRONG_CONV_MODE` and return without any action.

*Note: SW groups configured in continuous conversion mode shall raise development error `ADC_E_WRONG_TRIGG_SRC` instead.*

**ADC304:** If development error detection for the ADC module is enabled: if the group is not enabled (with a previous call of `Adc_EnableHardwareTrigger`), the function `Adc_DisableHardwareTrigger` shall raise development error `ADC_E_IDLE` and return without any action.

**ADC298:** If development error detection for the ADC module is enabled: if called prior to initializing the ADC module, `Adc_DisableHardwareTrigger` shall raise development error `ADC_E_UNINIT` and return without any action.

*Note:*

*All groups which are enabled with `Adc_EnableHardwareTrigger` should also be disabled with `Adc_DisableHardwareTrigger`, before they are enabled again, even if they are implicitly stopped because of the selected conversion mode (streaming buffer with linear access mode).*

### 8.3.9 Adc\_EnableGroupNotification

#### ADC372:

Service name:	Adc_EnableGroupNotification
<b>Syntax:</b>	void Adc_EnableGroupNotification( Adc_GroupType Group )
<b>Service ID[hex]:</b>	0x07
<b>Sync/Async:</b>	Synchronous
<b>Reentrancy:</b>	Reentrant
<b>Parameters (in):</b>	Group Numeric ID of requested ADC Channel group.
<b>Parameters (inout):</b>	None
<b>Parameters (out):</b>	None
<b>Return value:</b>	None
<b>Description:</b>	Enables the notification mechanism for the requested ADC Channel group.

**ADC057:** The function Adc\_EnableGroupNotification shall enable the notification mechanism for the requested ADC Channel group.

**ADC100:** The function Adc\_EnableGroupNotification shall be pre-compile time configurable On/Off by the configuration parameter AdcGrpNotifCapability.

**ADC130:** If development error detection for the ADC module is enabled: if the channel group ID is non-existing, the function Adc\_EnableGroupNotification shall raise development error ADC\_E\_PARAM\_GROUP and return without any action

**ADC165:** If development error detection for the ADC module is enabled: if the group notification function pointer is NULL, the function Adc\_EnableGroupNotification shall raise development error ADC\_E\_NOTIF\_CAPABILITY and return without any action.

**ADC299:** If development error detection for the ADC module is enabled: if called prior to initializing the ADC module, Adc\_EnableGroupNotification shall raise development error ADC\_E\_UNINIT and return without any action.

### 8.3.10 Adc\_DisableGroupNotification

#### ADC373:

Service name:	Adc_DisableGroupNotification
<b>Syntax:</b>	void Adc_DisableGroupNotification( Adc_GroupType Group )
<b>Service ID[hex]:</b>	0x08
<b>Sync/Async:</b>	Synchronous
<b>Reentrancy:</b>	Reentrant
<b>Parameters (in):</b>	Group Numeric ID of requested ADC Channel group.
<b>Parameters (inout):</b>	None
<b>Parameters (out):</b>	None
<b>Return value:</b>	None
<b>Description:</b>	Disables the notification mechanism for the requested ADC Channel group.

**ADC058:** The function Adc\_DisableGroupNotification shall disable the notification mechanism for the requested ADC Channel group.

**ADC101:** The function Adc\_DisableGroupNotification shall be pre-compile time configurable On/Off by the configuration parameter AdcGrpNotifCapability.

**ADC131:** If development error detection for the ADC module is enabled: if the channel group ID is non-existing, the function Adc\_DisableGroupNotification shall raise development error ADC\_E\_PARAM\_GROUP and return without any action.

**ADC166:** If development error detection for the ADC module is enabled: if the group notification function pointer is NULL, the function Adc\_DisableGroupNotification shall raise development error ADC\_E\_NOTIF\_CAPABILITY and return without any action.

**ADC300:** If development error detection for the ADC module is enabled: if called prior to initializing the ADC module, Adc\_DisableGroupNotification shall raise development error ADC\_E\_UNINIT and return without any action.

### 8.3.11 Adc\_GetGroupStatus

#### ADC374:

<b>Service name:</b>	Adc_GetGroupStatus		
<b>Syntax:</b>	Adc_StatusType	Adc_GroupType	Adc_GetGroupStatus (Group)
<b>Service ID[hex]:</b>	0x09		
<b>Sync/Async:</b>	Synchronous		
<b>Reentrancy:</b>	Reentrant		
<b>Parameters (in):</b>	Group	Numeric ID of requested ADC Channel group.	
<b>Parameters (inout):</b>	None		
<b>Parameters (out):</b>	None		
<b>Return value:</b>	Adc_StatusType	Conversion status for the requested group.	
<b>Description:</b>	Returns the conversion status of the requested ADC Channel group.		

**ADC220:** The function Adc\_GetGroupStatus shall return the conversion status of the requested ADC Channel group.

**ADC221:** The function Adc\_GetGroupStatus shall return ADC\_IDLE:

- If Adc\_GetGroupStatus is called before the conversion of the requested group has been started
- For groups with trigger source software: If Adc\_GetGroupStatus is called after the conversion was stopped with Adc\_StopGroupConversion
- In continuous group conversion mode with linear streaming access mode: If Adc\_GetGroupStatus is called after calling Adc\_GetStreamLastPointer
- In continuous group conversion mode with linear streaming access mode: If Adc\_GetGroupStatus is called after calling Adc\_ReadGroup
- In one-shot SW conversion mode: If Adc\_GetGroupStatus is called after calling Adc\_GetStreamLastPointer.
- In one-shot SW conversion mode: If Adc\_GetGroupStatus is called after calling Adc\_ReadGroup.
- For groups with trigger source hardware: If Adc\_GetGroupStatus is called after calling Adc\_DisableHardwareTrigger
- For groups with trigger source hardware and linear streaming access mode: If Adc\_GetGroupStatus is called after calling Adc\_GetStreamLastPointer.
- For groups with trigger source hardware and linear streaming access mode: If Adc\_GetGroupStatus is called after calling Adc\_ReadGroup.

**ADC222:** The function `Adc_GetGroupStatus` shall return `ADC_BUSY`:

- If it is called while the first conversion round of the requested group is still ongoing (continuous conversion mode).
- Once trigger is enabled for group with HW trigger source.
- Once `Adc_StartGroupConversion` is called for group with SW trigger source.
- In continuous group conversion mode with single access mode: If `Adc_GetGroupStatus` is called after calling `Adc_GetStreamLastPointer`
- In continuous group conversion mode with single access mode: If `Adc_GetGroupStatus` is called after calling `Adc_ReadGroup`.
- In continuous group conversion mode with circular streaming access mode: If `Adc_GetGroupStatus` is called after calling `Adc_GetStreamLastPointer`
- In continuous group conversion mode with circular streaming access mode: If `Adc_GetGroupStatus` is called after calling `Adc_ReadGroup`.
- In one-shot HW conversion mode: If `Adc_GetGroupStatus` is called after calling `Adc_GetStreamLastPointer`.
- In one-shot HW conversion mode: If `Adc_GetGroupStatus` is called after calling `Adc_ReadGroup`.

**ADC224:** The function `Adc_GetGroupStatus` shall return `ADC_COMPLETED`:

- If it is called after a conversion round (not the final one) of the requested group has been finished.

**ADC325:** The function `Adc_GetGroupStatus` shall return `ADC_STREAM_COMPLETED`:

- If it is called in single access mode after one conversion round is completed.
- If it is called in streaming access mode after the number of conversion rounds of the requested group have been finished, to fill the streaming buffer completely.

**ADC226:** The function `Adc_GetGroupStatus` shall provide atomic access to the status data by the use of atomic instructions.

**ADC305:** To guarantee consistent returned values, it is assumed that ADC group conversion is always started (or enabled in case of HW group) successfully by SW before status polling begins.

**ADC225:** If development error detection for the ADC module is enabled: if the channel group ID is non-existing, the function `Adc_GetGroupStatus` shall raise development error `ADC_E_PARAM_GROUP` and return `ADC_IDLE` without any action.

**ADC301:** If development error detection for the ADC module is enabled: if called prior to initializing the ADC module, `Adc_GetGroupStatus` shall raise development error `ADC_E_UNINIT` and return `ADC_IDLE` without any action.



### 8.3.12 Adc\_GetStreamLastPointer

#### ADC375:

<b>Service name:</b>	Adc_GetStreamLastPointer	
<b>Syntax:</b>	<pre>Adc_StreamNumSampleType Adc_GetStreamLastPointer(     Adc_GroupType Group,     Adc_ValueGroupType** PtrToSamplePtr )</pre>	
<b>Service ID[hex]:</b>	0x0b	
<b>Sync/Async:</b>	Synchronous	
<b>Reentrancy:</b>	Reentrant	
<b>Parameters (in):</b>	Group	Numeric ID of requested ADC Channel group.
<b>Parameters (inout):</b>	None	
<b>Parameters (out):</b>	PtrToSamplePtr	Pointer to result buffer pointer.
<b>Return value:</b>	Adc_StreamNumSampleType	Number of valid samples per channel.
<b>Description:</b>	Returns the number of valid samples per channel, stored in the result buffer. Reads a pointer, pointing to a position in the group result buffer. With the pointer position, the results of all group channels of the last completed conversion round can be accessed. With the pointer and the return value, all valid group conversion results can be accessed (the user has to take the layout of the result buffer into account).	

**ADC214:** The function Adc\_GetStreamLastPointer shall set the pointer, passed as parameter (PtrToSamplePtr) to point in the ADC result buffer to the latest result of the first group channel of the last completed conversion round.

**ADC418:** All values which the ADC driver stores in the ADC result buffer, are left without further scaling and shall be right-aligned.

**ADC387:** The function Adc\_GetStreamLastPointer shall return the number of valid samples per channel, stored in the ADC result buffer.

*Note: Valid samples are in the ADC result buffer when the group is in state ADC\_COMPLETED or ADC\_STREAM\_COMPLETED. In state ADC\_BUSY or ADC\_IDLE the value 0 is returned.*

*Note: The return value is 1 for groups with single access mode configuration, if valid samples are stored in the ADC result buffer.*

**ADC216:** When called while the group status is ADC\_BUSY (a conversion of the group is in progress), the function Adc\_GetStreamLastPointer shall set the pointer, passed as parameter (PtrToSamplePtr), to NULL and return 0.

**ADC219:** The ADC module's environment shall guarantee the consistency of the data that has been read by checking the return value of Adc\_GetGroupStatus.

*Note: See also ADC140.*

**ADC326:** Calling function `Adc_GetStreamLastPointer` while group status is `ADC_STREAM_COMPLETED` shall trigger a state transition to `ADC_BUSY` for continuous conversion modes (single access mode or circular streaming buffer mode) and hardware triggered groups in single access mode or circular streaming access mode.

**ADC327:** Calling function `Adc_GetStreamLastPointer` while group status is `ADC_STREAM_COMPLETED` shall trigger a state transition to `ADC_IDLE` for software conversion modes which automatically stop the conversion (streaming buffer with linear access mode or one-shot conversion mode with single access) and for the hardware triggered conversion mode in combination with linear streaming access mode.

**ADC328:** Calling function `Adc_GetStreamLastPointer` while group status is `ADC_COMPLETED` shall trigger a state transition to `ADC_BUSY`.

**ADC215:** If development error detection for the ADC module is enabled: when called while the group status is `ADC_IDLE` and the group conversion was not started (no results are available from previous conversions) , the function `Adc_GetStreamLastPointer` shall raise development error `ADC_E_IDLE`, set the pointer, passed as parameter (`PtrToSamplePtr`), to `NULL` and return 0.

**ADC218:** If development error detection for the ADC module is enabled: if the group ID is non-existent, the function `Adc_GetStreamLastPointer` shall raise development error `ADC_E_PARAM_GROUP`, set the pointer, passed as parameter (`PtrToSamplePtr`), to `NULL` and return 0 without any further action.

**ADC302:** If development error detection for the ADC module is enabled: if called prior to initializing the driver, the function `Adc_GetStreamLastPointer` shall raise development error `ADC_E_UNINIT`, set the pointer, passed as parameter (`PtrToSamplePtr`), to `NULL` and return 0 without any further action.

### 8.3.13 Adc\_GetVersionInfo

#### ADC376:

Service name:	Adc_GetVersionInfo	
<b>Syntax:</b>	void	Adc_GetVersionInfo( Std_VersionInfoType* versioninfo )
<b>Service ID[hex]:</b>	0x0a	
<b>Sync/Async:</b>	Synchronous	
<b>Reentrancy:</b>	Non Reentrant	
<b>Parameters (in):</b>	None	
<b>Parameters (inout):</b>	None	
<b>Parameters (out):</b>	versioninfo	Pointer to where to store the version information of this module.
<b>Return value:</b>	None	
<b>Description:</b>	Returns the version information of this module.	

**ADC236:** The function Adc\_GetVersionInfo shall read the version information of the ADC module. The version information includes:

- Module Id.
- Vendor Id.
- Vendor specific version numbers (BSW00407).

**ADC324:** If development error detection is enabled: The function Adc\_GetVersionInfo shall raise the error ADC\_E\_UNINIT if this function was called prior to initializing the driver.

*Note: The correct version info is read correctly, independent from the DET generation.*

**ADC237:** The function Adc\_GetVersionInfo shall be pre-compile time configurable On/Off by the configuration parameter AdcVersionInfoApi (see chapter 10.2).

## 8.4 Call-back Notifications

Since the ADC Driver is a module on the lowest architectural layer it doesn't provide any call-back functions for lower layer modules.

## 8.5 Scheduled functions

None

## 8.6 Expected Interfaces

In this chapter all interfaces required from other modules are listed.

### 8.6.1 Mandatory Interfaces

This chapter defines all interfaces which are required to fulfill a core functionality of the module.

### 8.6.2 Optional Interfaces

This chapter defines all interfaces which are required to fulfill an optional functionality of the module.

#### ADC377:

API function	Description
Dem_ReportErrorStatus	Reports errors to the DEM.
Det_ReportError	Service to report development errors.

### 8.6.3 Configurable interfaces

In this chapter all interfaces are listed where the target function could be configured. The target function is usually a call-back function. The names of this kind of interfaces are not fixed because they are configurable.

**ADC078:** The ADC module's ISR's, providing the "conversion completed events", shall be responsible for resetting the interrupt flags (if needed by hardware) and calling the associated notification function.

*Note: The notification functions IoHwAb\_Adc\_Notification\_<GroupID> run in interrupt context. It's the responsibility of the user to keep the code of these functions reasonably short. The names of the group notification functions are configurable (see ADC402).*

#### ADC082

Service name:	IoHwAb_Adc_Notification_<GroupID>
<b>Syntax:</b>	void IoHwAb_Adc_Notification_<GroupID> ( )
<b>Sync/Async:</b>	Synchronous
<b>Reentrancy:</b>	Re-entrancy of this API call depends on the users code.
<b>Parameters (in):</b>	None
<b>Parameters (inout):</b>	None
<b>Parameters (out):</b>	None
<b>Return value:</b>	None
<b>Description:</b>	--

**ADC104:** The ADC Driver shall support an individual notification per ADC Channel group (if capability is configured) that is called whenever the conversion for all channels of that group is completed.

**ADC083:** When the notification mechanism is disabled, the ADC module shall send no notification.

**ADC416:** When the notifications are re-enabled, the ADC module shall not send notifications for events that occurred while notifications have been disabled.

**ADC084:** For every group, a particular notification call-back has to be configured. This can be a function pointer or a NULL pointer.

**ADC080:** If for a notification call-back the NULL pointer is configured, no call-back shall be executed.

**ADC085:** The call-back notifications shall be configurable as pointers to user defined functions within the configuration structure. For all available channel groups, call-back functions have to be declared during the configuration phase of the module.

## 9 Sequence diagrams

### 9.1 Initialization of the ADC Driver

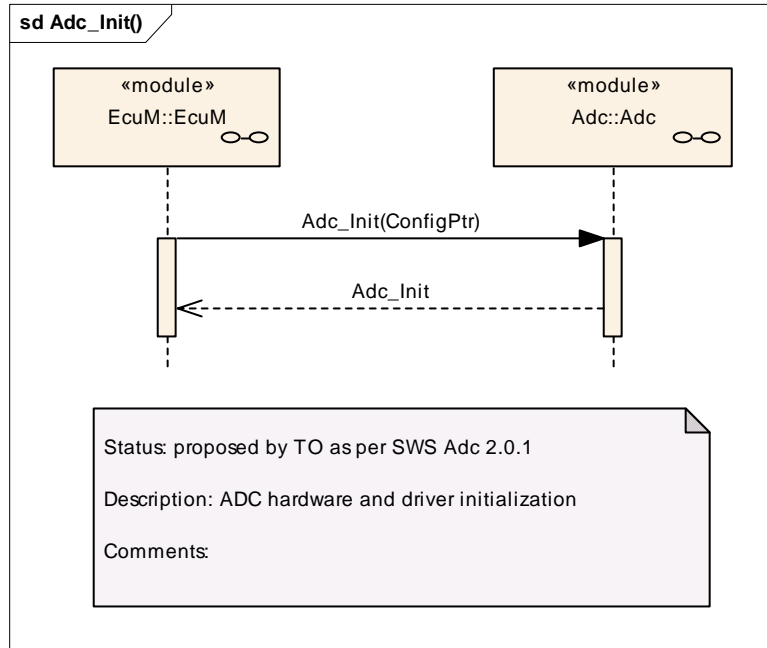

**Figure 13: Initialization of the ADC Driver**

## 9.2 De-Initialization of the ADC Driver

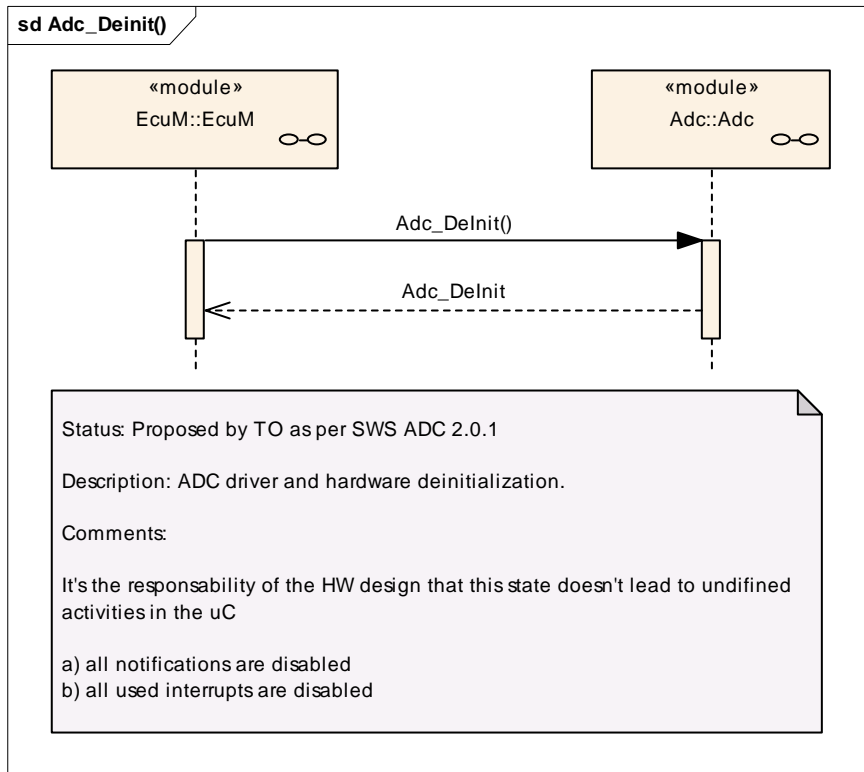

**Figure 14: De-Initialization of the ADC Driver**

### 9.3 Software triggered One-Shot conversion without notification

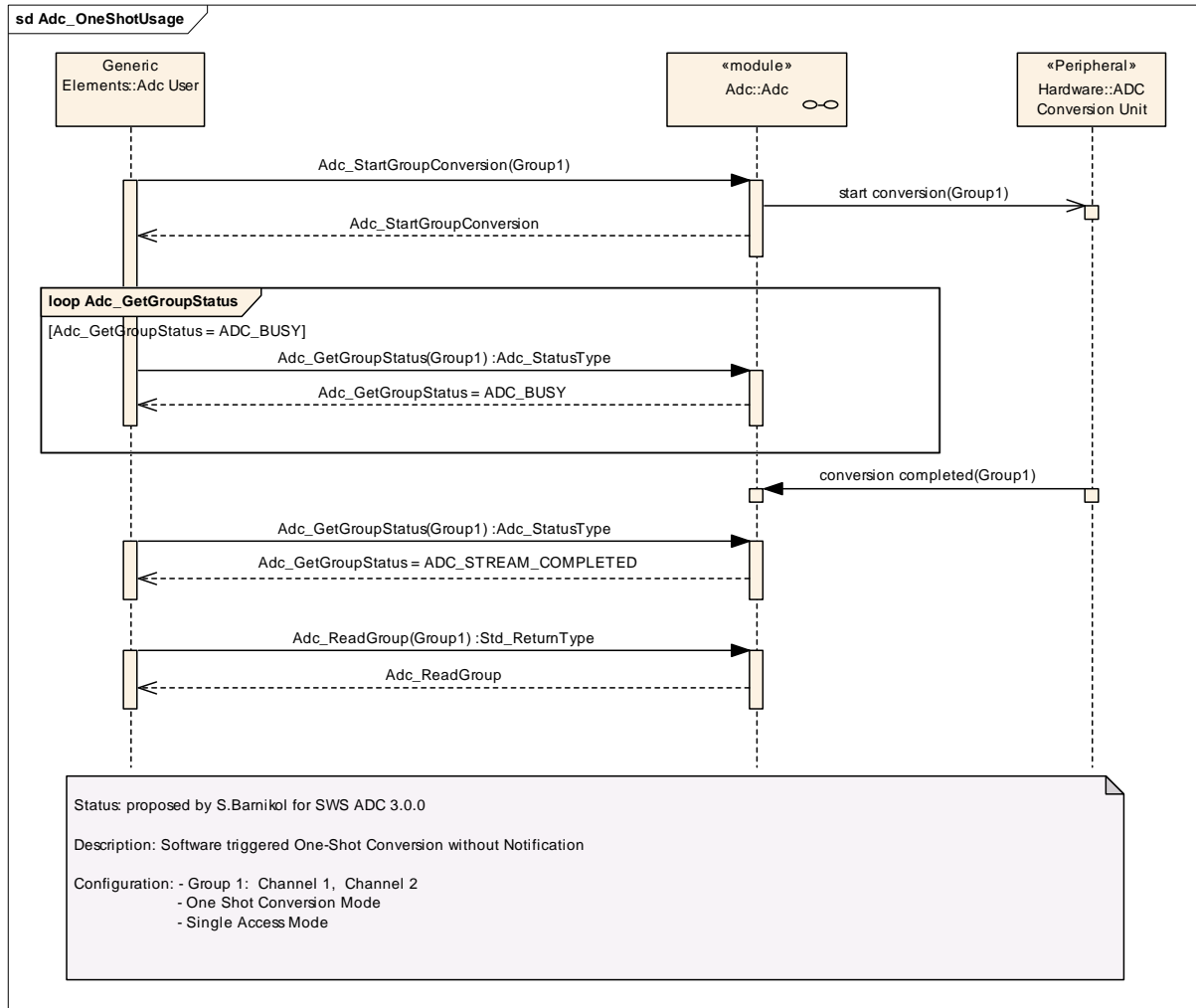

**Figure 15: Software triggered one-shot conversion without notification**



### 9.4 Software triggered continuous conversion with notification

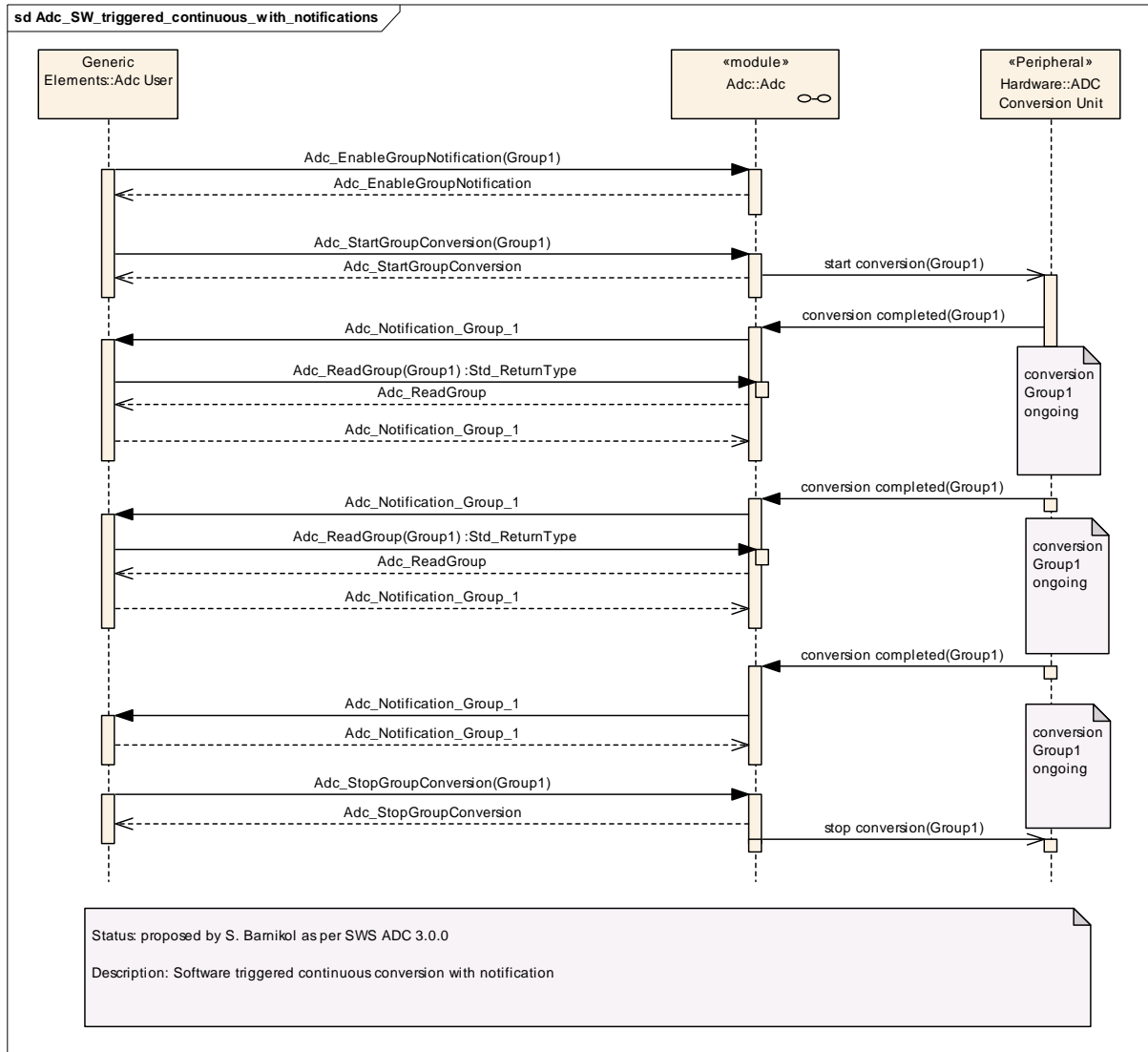

**Figure 16: Software triggered continuous conversion with notification**

### 9.5 Hardware triggered One-Shot conversion with notification

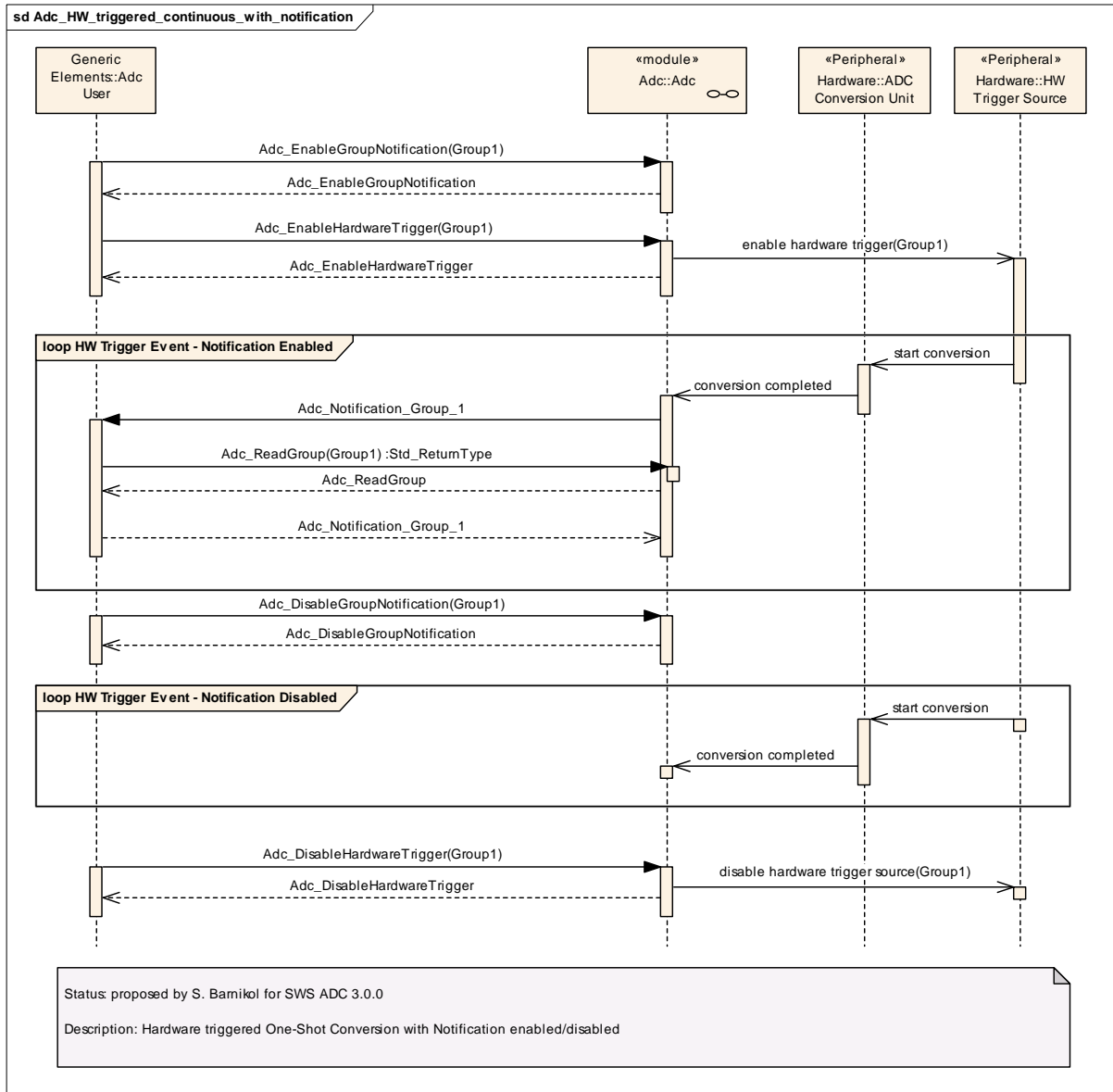

**Figure 17: Hardware triggered one-shot conversion with notification**

### 9.6 HW Trigger - One-Shot conversion - Linear Streaming

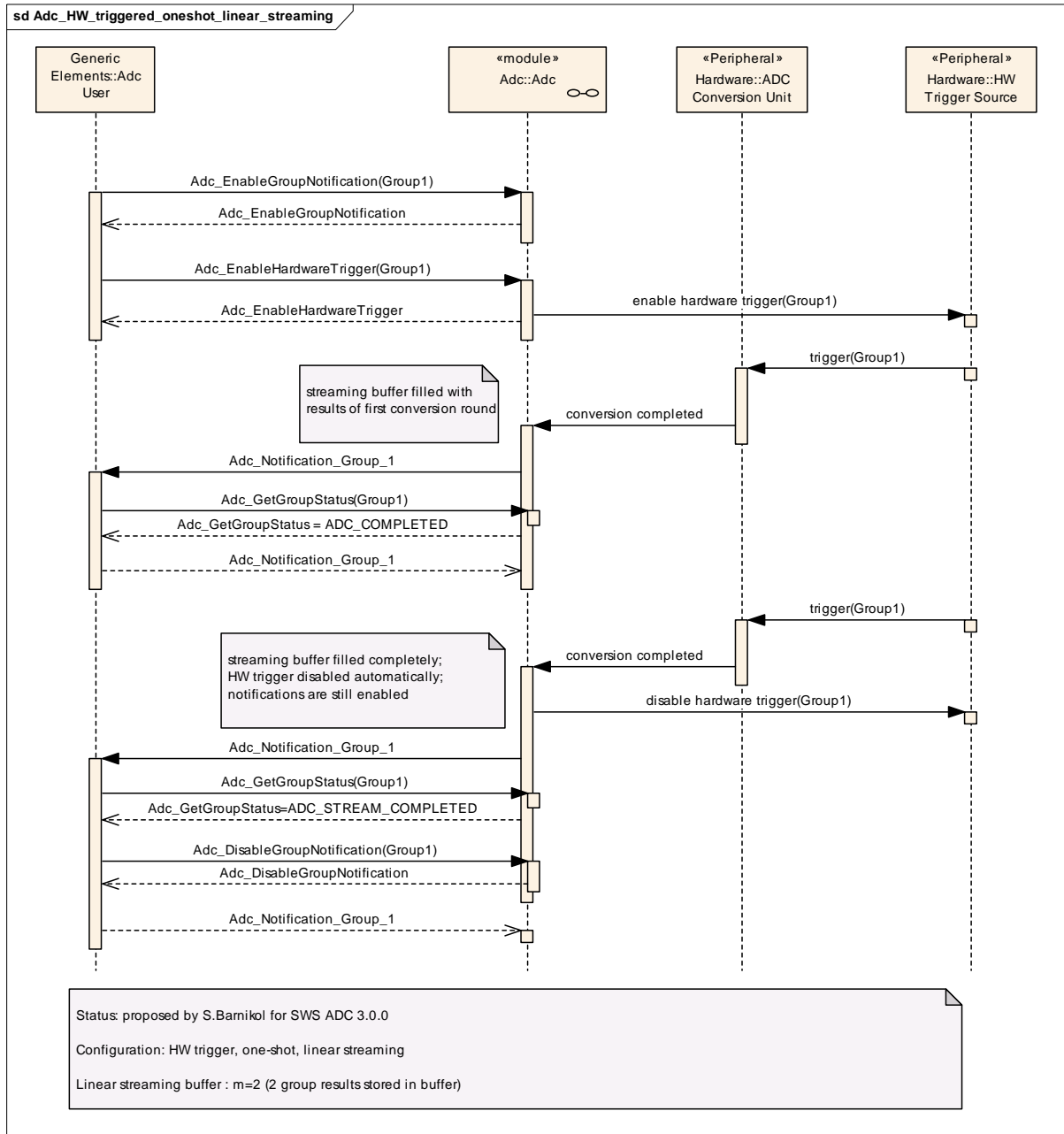

**Figure 18: Hardware triggered one-shot conversion – linear streaming**

### 9.7 No Priority Mechanism – No Queuing

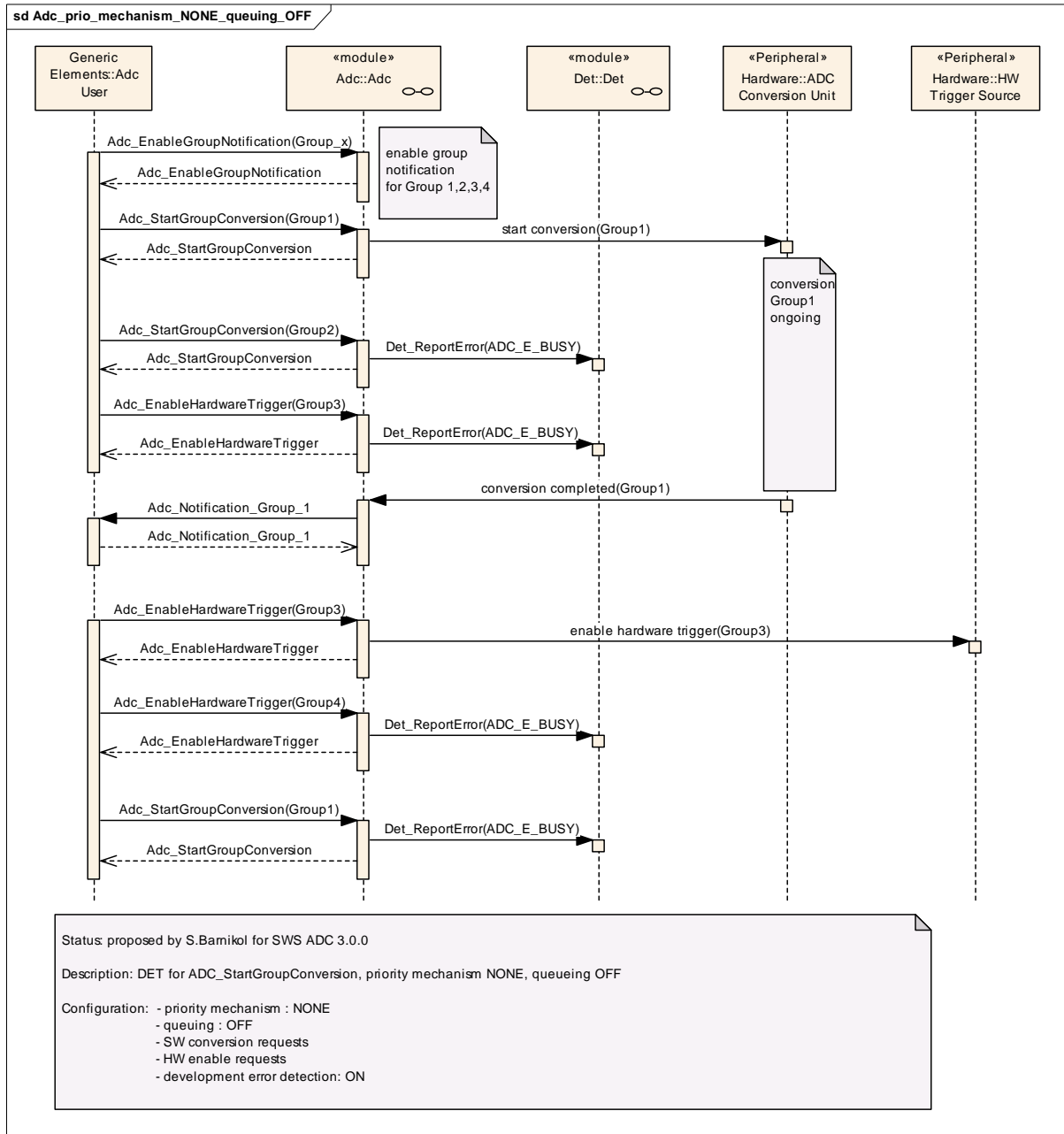
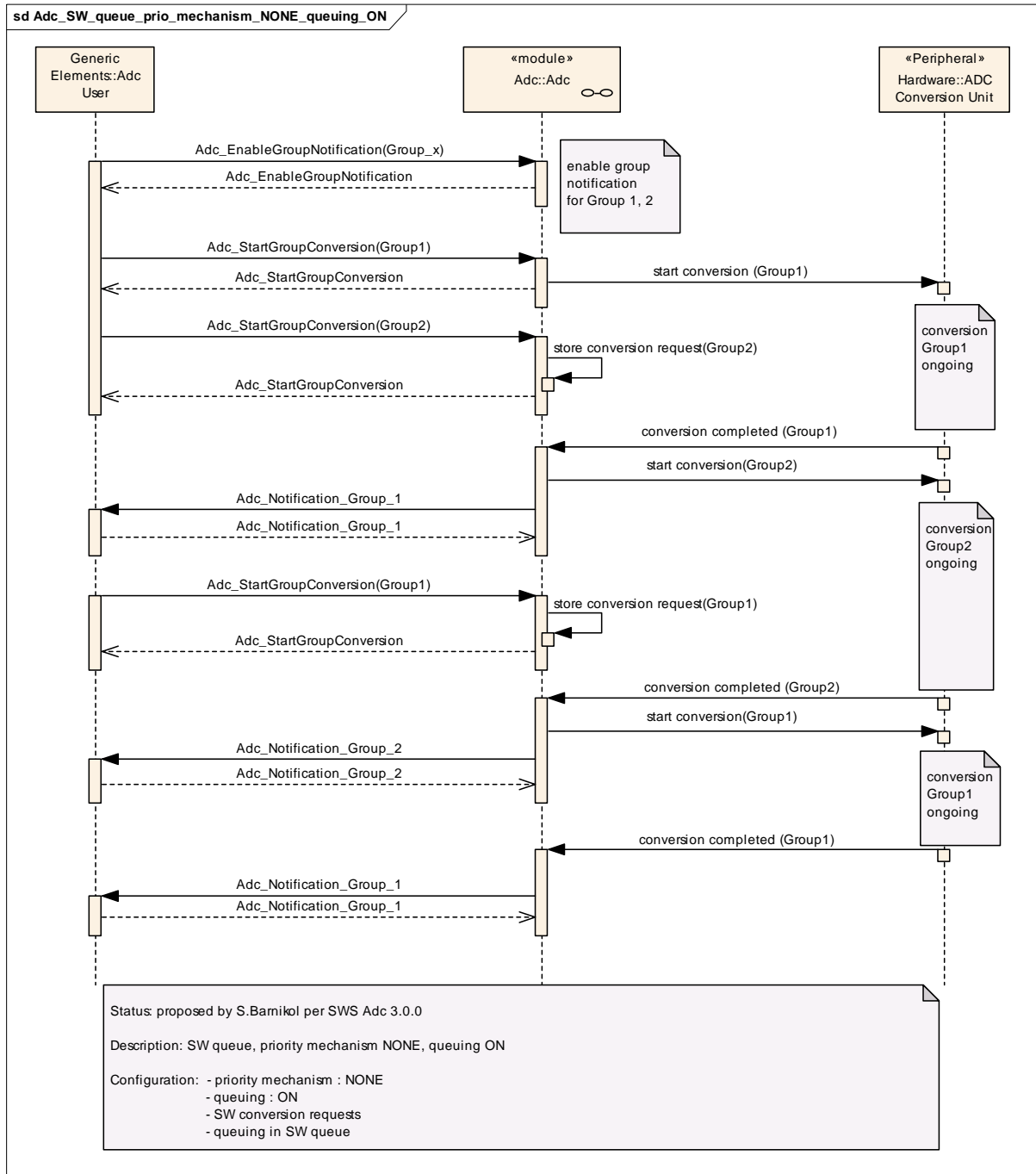

Figure 19: No priority mechanism – no queuing

### 9.8 No Priority Mechanism – SW Queuing



**Figure 20: No priority mechanism – software queuing**

### 9.9 HW\_SW Priority Mechanism – SW Queuing

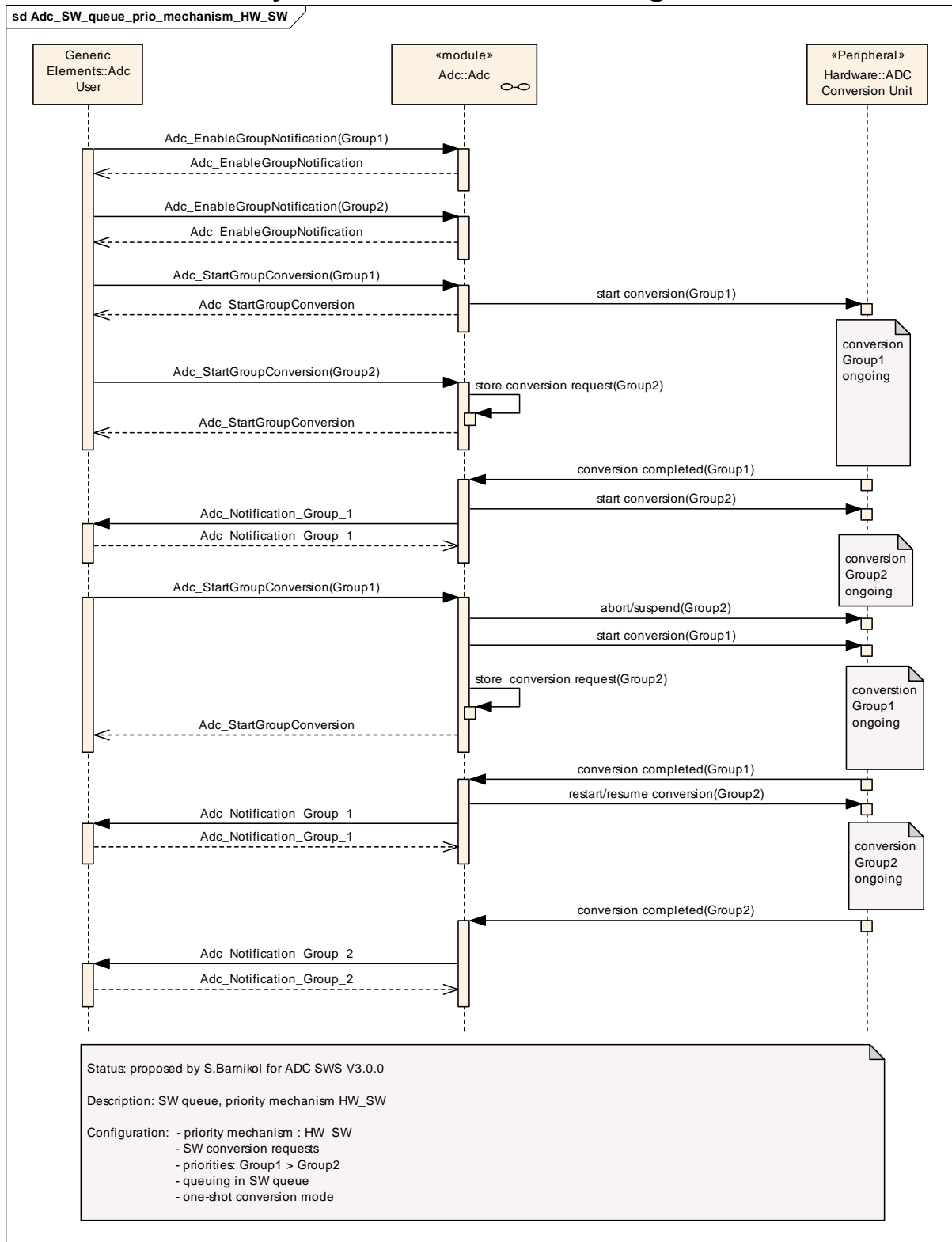
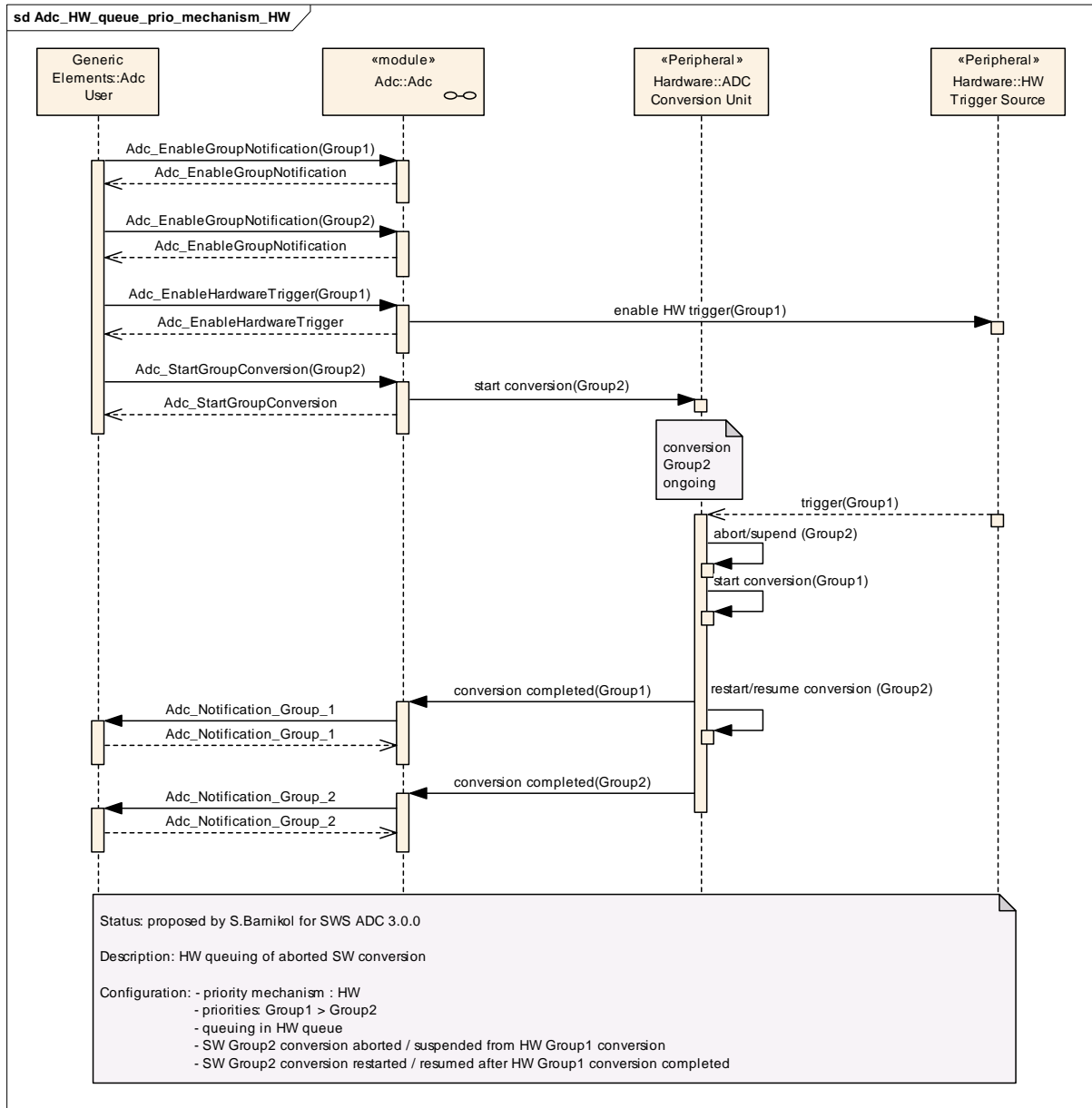

Figure 20: Hardware/software priority mechanism – SW queuing

### 9.10 HW Priority Mechanism – HW Queuing



**Figure 22: Hardware priority mechanism – HW queuing**

### 9.11 HW\_SW Priority Mechanism – HW/SW Queuing

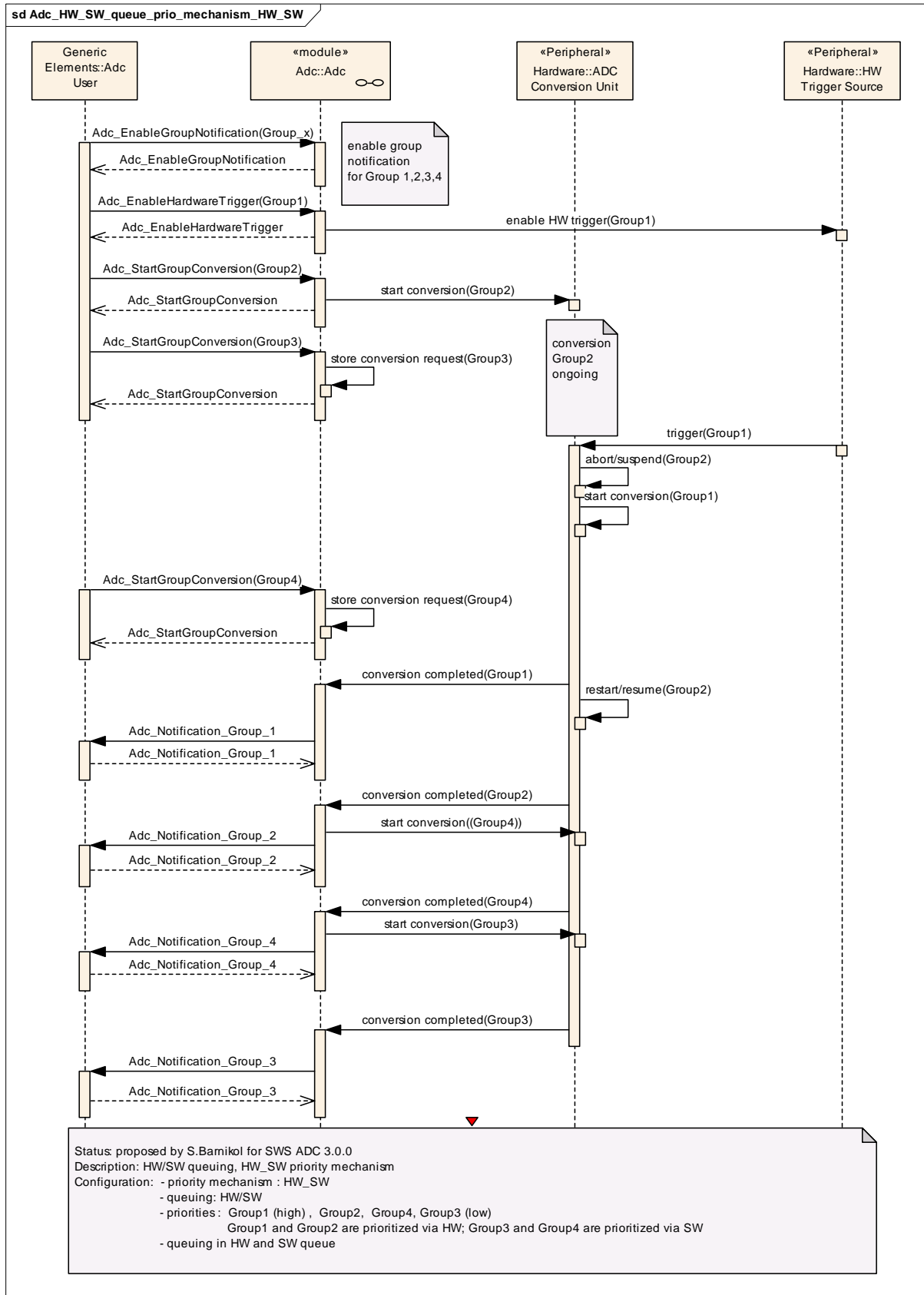

**Figure 23: Hardware/software priority mechanism – hardware/software queuing**





## 10 Configuration specification

In general, this chapter defines configuration parameters and their clustering into containers. In order to support the specification Chapter 10.1 describes fundamentals. It also specifies a template (table) you shall use for the parameter specification. We intend to leave Chapter 10.1 in the specification to guarantee comprehension.

Chapter 10.2 specifies the structure (containers) and the parameters of the module ADC Driver.

Chapter 10.2.3 specifies published information of the module ADC Driver.

### 10.1 How to read this chapter

In addition to this section, it is highly recommended to read the documents:

- AUTOSAR Layered Software Architecture
  - AUTOSAR ECU Configuration Specification
- This document describes the AUTOSAR configuration methodology and the AUTOSAR configuration metamodel in detail.

The following is only a short survey of the topic and it will not replace the ECU Configuration Specification document.

#### 10.1.1 Configuration and configuration parameters

Configuration parameters define the variability of the generic part(s) of an implementation of a module. This means that only generic or configurable module implementation can be adapted to the environment (software/hardware) in use during system and/or ECU configuration.

The configuration of parameters can be achieved at different times during the software process: before compile time, before link time or after build time. In the following, the term “configuration class” (of a parameter) shall be used in order to refer to a specific configuration point in time.

#### 10.1.2 Containers

Containers structure the set of configuration parameters. This means:

- *all* configuration parameters are kept in containers.
- (sub-) containers can reference (sub-) containers. It is possible to assign a multiplicity to these references. The multiplicity then defines the possible number of instances of the contained parameters.

### 10.1.3 Specification template for configuration parameters

The following tables consist of three sections:

- the general section
- the configuration parameter section
- the section of included/referenced containers

Pre-compile time - specifies whether the configuration parameter shall be of configuration class *Pre-compile time* or not

Label	Description
x	The configuration parameter shall be of configuration class <i>Pre-compile time</i> .
--	The configuration parameter shall never be of configuration class <i>Pre-compile time</i> .

Link time - specifies whether the configuration parameter shall be of configuration class *Link time* or not

Label	Description
x	The configuration parameter shall be of configuration class <i>Link time</i> .
--	The configuration parameter shall never be of configuration class <i>Link time</i> .

Post Build - specifies whether the configuration parameter shall be of configuration class *Post Build* or not

Label	Description
x	The configuration parameter shall be of configuration class <i>Post Build</i> and no specific implementation is required.
L	<i>Loadable</i> – the configuration parameter shall be of configuration class <i>Post Build</i> and only one configuration parameter set resides in the ECU.
M	<i>Multiple</i> – the configuration parameter shall be of configuration class <i>Post Build</i> and is selected out of a set of multiple parameters by passing a dedicated pointer to the init function of the module.
--	The configuration parameter shall never be of configuration class <i>Post Build</i> .

## 10.2 Configuration and configuration parameters

The following chapters summarize all configuration parameters. The detailed meanings of the parameters describe Chapter 7 and Chapter 8.

### 10.2.1 Variants

**ADC362: Variant PC:** This variant is limited to pre-compile configuration parameters only.

**ADC363: Variant PB:** This variant allows a mix of pre-compile time and post-build multiple selectable configuration parameters.

### 10.2.2 Adc

Module Name	Adc
-------------	-----

<b>Module Description</b>	Configuration of the Adc (Analog Digital Conversion) module.
---------------------------	--

<b>Included Containers</b>		
<b>Container Name</b>	<b>Multiplicity</b>	<b>Scope / Dependency</b>
AdcConfigSet	1	This is the base container that contains the post-build selectable configuration parameters
AdcGeneral	1	General configuration (parameters) of the ADC Driver software module.
AdcPublishedInformation	1	Additional published parameters not covered by CommonPublishedInformation container. Note that these parameters do not have any configuration class setting, since they are published information.

### 10.2.3 AdcGeneral

<b>SWS Item</b>	<b>ADC027 :</b>
<b>Container Name</b>	AdcGeneral{AdcDriverGeneralConfiguration}
<b>Description</b>	General configuration (parameters) of the ADC Driver software module.
<b>Configuration Parameters</b>	

<b>SWS Item</b>	<b>ADC404 :</b>		
<b>Name</b>	AdcDelnitApi {ADC_DEINIT_API}		
<b>Description</b>	Adds / removes the service Adc_Delnit() from the code. true: Adc_Delnit() can be used. false: Adc_Delnit() can not be used.		
<b>Multiplicity</b>	1		
<b>Type</b>	BooleanParamDef		
<b>Default value</b>	--		
<b>ConfigurationClass</b>	<b>Pre-compile time</b>	X	All Variants
	<b>Link time</b>	--	
	<b>Post-build time</b>	--	
<b>Scope / Dependency</b>	scope: Module		

<b>SWS Item</b>	<b>ADC405 :</b>		
<b>Name</b>	AdcDevErrorDetect {ADC_DEV_ERROR_DETECT}		
<b>Description</b>	Switches the Development Error Detection and Notification ON or OFF. true: Enabled. false: Disabled.		
<b>Multiplicity</b>	1		
<b>Type</b>	BooleanParamDef		
<b>Default value</b>	--		
<b>ConfigurationClass</b>	<b>Pre-compile time</b>	X	All Variants
	<b>Link time</b>	--	
	<b>Post-build time</b>	--	
<b>Scope / Dependency</b>	scope: Module		

<b>SWS Item</b>	<b>ADC391 :</b>		
<b>Name</b>	AdcEnableQueuing {ADC_ENABLE_QUEUING}		
<b>Description</b>	Determines, if the queuing mechanism is active in case of priority mechanism disabled. Note: If priority mechanism is enabled, queuing mechanism is always active and the parameter ADC_ENABLE_QUEUING is not evaluated. true: Enabled. false: Disabled.		
<b>Multiplicity</b>	1		
<b>Type</b>	BooleanParamDef		
<b>Default value</b>	--		
<b>ConfigurationClass</b>	<b>Pre-compile time</b>	X	All Variants

	<b>Link time</b>	--	
	<b>Post-build time</b>	--	
<b>Scope / Dependency</b>	scope: Module dependency: AdcPriorityImplementation: parameter is only evaluated for priority implementation ADC_PRIORITY_NONE.		

<b>SWS Item</b>	<b>ADC406 :</b>		
<b>Name</b>	AdcEnableStartStopGroupApi {ADC_ENABLE_START_STOP_GROUP_API}		
<b>Description</b>	Adds / removes the services Adc_StartGroupConversion() and Adc_StopGroupConversion() from the code. true: Adc_StartGroupConversion() and Adc_StopGroupConversion() can be used. false: Adc_StartGroupConversion() and Adc_StopGroupConversion() can not be used.		
<b>Multiplicity</b>	1		
<b>Type</b>	BooleanParamDef		
<b>Default value</b>	--		
<b>ConfigurationClass</b>	<b>Pre-compile time</b>	X	All Variants
	<b>Link time</b>	--	
	<b>Post-build time</b>	--	
<b>Scope / Dependency</b>	scope: Module		

<b>SWS Item</b>	<b>ADC105 :</b>		
<b>Name</b>	AdcGrpNotifCapability {ADC_GRP_NOTIF_CAPABILITY}		
<b>Description</b>	Determines, if the group notification mechanism (the functions to enable and disable the notifications) is available at runtime. true: Enabled. false: Disabled.		
<b>Multiplicity</b>	1		
<b>Type</b>	BooleanParamDef		
<b>Default value</b>	--		
<b>ConfigurationClass</b>	<b>Pre-compile time</b>	X	All Variants
	<b>Link time</b>	--	
	<b>Post-build time</b>	--	
<b>Scope / Dependency</b>	scope: Module		

<b>SWS Item</b>	<b>ADC408 :</b>		
<b>Name</b>	AdcHwTriggerApi {ADC_HW_TRIGGER_API}		
<b>Description</b>	Adds / removes the services Adc_EnableHardwareTrigger() and Adc_DisableHardwareTrigger() from the code. true: Adc_EnableHardwareTrigger() and Adc_DisableHardwareTrigger() can be used. false: Adc_EnableHardwareTrigger() and Adc_DisableHardwareTrigger() can not be used.		
<b>Multiplicity</b>	1		
<b>Type</b>	BooleanParamDef		
<b>Default value</b>	--		
<b>ConfigurationClass</b>	<b>Pre-compile time</b>	X	All Variants
	<b>Link time</b>	--	
	<b>Post-build time</b>	--	
<b>Scope / Dependency</b>	scope: Module		

<b>SWS Item</b>	<b>ADC393 :</b>		
<b>Name</b>	AdcPriorityImplementation {ADC_PRIORITY_IMPLEMENTATION}		
<b>Description</b>	Determines whether a priority mechanism is available for prioritization of the conversion requests and if available, the type of prioritization mechanism. The selection applies for groups with trigger source software and trigger source hardware. Two types of prioritization mechanism can be selected. The		

	hardware prioritization mechanism (AdcPriorityHw) uses the ADC hardware features for prioritization of the software conversion requests and hardware trigger signals for groups with trigger source hardware. The mixed hardware and software prioritization mechanism (AdcPriorityHwSw) uses the ADC hardware features for prioritization of ADC hardware trigger for groups with trigger source hardware and a software implemented prioritization mechanism for groups with trigger source software. The group priorities for software triggered groups are typically configured with lower priority levels than the group priorities for hardware triggered groups. ImplementationType: Adc_PriorityImplementationType		
<b>Multiplicity</b>	1		
<b>Type</b>	EnumerationParamDef		
<b>Range</b>	ADC_PRIORITY_HW	Hardware priority mechanism is available only	
	ADC_PRIORITY_HW_SW	Hardware and software priority mechanism is available	
	ADC_PRIORITY_NONE	priority mechanism is not available	
<b>ConfigurationClass</b>	<b>Pre-compile time</b>	X	All Variants
	<b>Link time</b>	--	
	<b>Post-build time</b>	--	
<b>Scope / Dependency</b>	scope: Module		

<b>SWS Item</b>	<b>ADC394 :</b>		
<b>Name</b>	AdcReadGroupApi {ADC_READ_GROUP_API}		
<b>Description</b>	Adds / removes the service Adc_ReadGroup() and from the code. true: Adc_ReadGroup() can be used. false: Adc_ReadGroup() can not be used.		
<b>Multiplicity</b>	1		
<b>Type</b>	BooleanParamDef		
<b>Default value</b>	--		
<b>ConfigurationClass</b>	<b>Pre-compile time</b>	X	All Variants
	<b>Link time</b>	--	
	<b>Post-build time</b>	--	
<b>Scope / Dependency</b>	scope: Module		

<b>SWS Item</b>	<b>ADC409 :</b>		
<b>Name</b>	AdcVersionInfoApi {ADC_VERSION_INFO_API}		
<b>Description</b>	Adds / removes the service Adc_GetVersionInfo() from the code. true: Adc_GetVersionInfo() can be used. false: Adc_GetVersionInfor() can not be used.		
<b>Multiplicity</b>	1		
<b>Type</b>	BooleanParamDef		
<b>Default value</b>	--		
<b>ConfigurationClass</b>	<b>Pre-compile time</b>	X	All Variants
	<b>Link time</b>	--	
	<b>Post-build time</b>	--	
<b>Scope / Dependency</b>	scope: Module		

**No Included Containers**

### 10.2.4 AdcConfigSet

<b>SWS Item</b>	<b>ADC390 :</b>		
<b>Container Name</b>	AdcConfigSet [Multi Config Container]		
<b>Description</b>	This is the base container that contains the post-build selectable configuration parameters		
<b>Configuration Parameters</b>			

<b>Included Containers</b>		
<b>Container Name</b>	<b>Multiplicity</b>	<b>Scope / Dependency</b>
AdcHwUnit	1..*	This container contains the Driver configuration (parameters) depending on grouping of channels This container could contain HW specific parameters which are not defined in the Standardized Module Definition. They must be added in the Vendor Specific Module Definition.

### 10.2.5 AdcChannel

<b>SWS Item</b>	<b>ADC268 :</b>
<b>Container Name</b>	AdcChannel{AdcChannelConfiguration}
<b>Description</b>	This container contains the channel configuration (parameters) depending on the hardware capability. The organization of this data structure could contain dependencies to the microcontroller so this is left up to the implementer and its location is left up to the configuration. Note: Since a AdcChannel can be part of several AdcGroups, this container is not realized as a subcontainer of AdcGroup but instead as a subcontainer of AdcHwUnit.
<b>Configuration Parameters</b>	

<b>SWS Item</b>	<b>ADC011 :</b>		
<b>Name</b>	AdcChannelConvTime {ADC_CHANNEL_CONV_TIME}		
<b>Description</b>	Configuration of conversion time, i.e. the time during which the analogue value is converted into digital representation, (in clock cycles) for each channel, if supported by hardware. ImplementationType: Adc_ConversionTimeType		
<b>Multiplicity</b>	0..1		
<b>Type</b>	IntegerParamDef		
<b>Default value</b>	--		
<b>ConfigurationClass</b>	<b>Pre-compile time</b>	X	VARIANT-PRE-COMPILE
	<b>Link time</b>	--	
	<b>Post-build time</b>	M	VARIANT-POST-BUILD
<b>Scope / Dependency</b>	scope: Module		

<b>SWS Item</b>	<b>ADC392 :</b>		
<b>Name</b>	AdcChannelId		
<b>Description</b>	Numeric ID of the channel. This parameter is the symbolic name to be used on the API. This symbolic name allows accessing Channel data. This value will be assigned to the symbolic name derived of the AdcChannel container shortName. ImplementationType: Adc_ChannelType		
<b>Multiplicity</b>	1		
<b>Type</b>	IntegerParamDef (Symbolic Name generated for this parameter)		
<b>Default value</b>	--		
<b>ConfigurationClass</b>	<b>Pre-compile time</b>	X	VARIANT-PRE-COMPILE
	<b>Link time</b>	--	
	<b>Post-build time</b>	M	VARIANT-POST-BUILD
<b>Scope / Dependency</b>	scope: Module		

<b>SWS Item</b>	<b>ADC089 :</b>
<b>Name</b>	AdcChannelRefVoltsrcHigh {ADC_CHANNEL_REF_VOLTSRC_HIGH}
<b>Description</b>	Upper reference voltage source for each channel. ImplementationType: Adc_VoltageSourceType
<b>Multiplicity</b>	0..1
<b>Type</b>	IntegerParamDef
<b>Default value</b>	--

<b>ConfigurationClass</b>	<b>Pre-compile time</b>	X	VARIANT-PRE-COMPILE
	<b>Link time</b>	--	
	<b>Post-build time</b>	M	VARIANT-POST-BUILD
<b>Scope / Dependency</b>	scope: Module		

<b>SWS Item</b>	<b>ADC023 :</b>		
<b>Name</b>	AdcChannelRefVoltsrcLow {ADC_CHANNEL_REF_VOLTSRC_LOW}		
<b>Description</b>	Lower reference voltage source for each channel. ImplementationType: Adc_VoltageSourceType		
<b>Multiplicity</b>	0..1		
<b>Type</b>	IntegerParamDef		
<b>Default value</b>	--		
<b>ConfigurationClass</b>	<b>Pre-compile time</b>	X	VARIANT-PRE-COMPILE
	<b>Link time</b>	--	
	<b>Post-build time</b>	M	VARIANT-POST-BUILD
<b>Scope / Dependency</b>	scope: Module		

<b>SWS Item</b>	<b>ADC019 :</b>		
<b>Name</b>	AdcChannelResolution {ADC_CHANNEL_RESOLUTION}		
<b>Description</b>	Channel resolution in bits. ImplementationType: Adc_ResolutionType		
<b>Multiplicity</b>	0..1		
<b>Type</b>	IntegerParamDef		
<b>Default value</b>	--		
<b>ConfigurationClass</b>	<b>Pre-compile time</b>	X	VARIANT-PRE-COMPILE
	<b>Link time</b>	--	
	<b>Post-build time</b>	M	VARIANT-POST-BUILD
<b>Scope / Dependency</b>	scope: Module dependency: AdcMaxChannelResolution: The actual resolution has to be less or equal than the maximum resolution.		

<b>SWS Item</b>	<b>ADC290 :</b>		
<b>Name</b>	AdcChannelSampTime {ADC_CHANNEL_SAMP_TIME}		
<b>Description</b>	Configuration of sampling time, i.e. the time during which the value is sampled, (in clock cycles) for each channel, if supported by hardware. ImplementationType: Adc_SamplingTimeType		
<b>Multiplicity</b>	0..1		
<b>Type</b>	IntegerParamDef		
<b>Default value</b>	--		
<b>ConfigurationClass</b>	<b>Pre-compile time</b>	X	VARIANT-PRE-COMPILE
	<b>Link time</b>	--	
	<b>Post-build time</b>	M	VARIANT-POST-BUILD
<b>Scope / Dependency</b>	scope: Module		

**No Included Containers**

### 10.2.6 AdcGroup

<b>SWS Item</b>	<b>ADC028 :</b>		
<b>Container Name</b>	AdcGroup{AdcGroupConfiguration}		
<b>Description</b>	This container contains the Group configuration (parameters).		
<b>Configuration Parameters</b>			

<b>SWS Item</b>	<b>ADC317 :</b>		
<b>Name</b>	AdcGroupAccessMode {ADC_GROUP_ACCESS_MODE}		



<b>Description</b>	Type of access mode to group conversion results. ImplementationType: Adc_GroupAccessModeType		
<b>Multiplicity</b>	1		
<b>Type</b>	EnumerationParamDef		
<b>Range</b>	ADC_ACCESS_MODE_SINGLE	Single value access mode	
	ADC_ACCESS_MODE_STREAMING	Streaming access mode	
<b>ConfigurationClass</b>	<b>Pre-compile time</b>	X	VARIANT-PRE-COMPILE
	<b>Link time</b>	--	
	<b>Post-build time</b>	M	VARIANT-POST-BUILD
<b>Scope / Dependency</b>	dependency: AdcGroupTriggSrc / AdcGroupConvMode: streaming access mode is not available for one-shot conversion mode with software trigger source.		

<b>SWS Item</b>	<b>ADC397 :</b>		
<b>Name</b>	AdcGroupConversionMode {ADC_GROUP_CONV_MODE}		
<b>Description</b>	Type of conversion mode supported by the driver. ImplementationType: Adc_GroupConvModeType		
<b>Multiplicity</b>	1		
<b>Type</b>	EnumerationParamDef		
<b>Range</b>	ADC_CONV_MODE_CONTINUOUS	Conversions of an ADC channel group are performed continuously after a software API call (start). The conversions itself are running automatically (no additional software or hardware trigger needed).	
	ADC_CONV_MODE_ONESHOT	The conversion of an ADC channel group is performed once after a trigger.	
<b>ConfigurationClass</b>	<b>Pre-compile time</b>	X	VARIANT-PRE-COMPILE
	<b>Link time</b>	--	
	<b>Post-build time</b>	M	VARIANT-POST-BUILD
<b>Scope / Dependency</b>	scope: Module dependency: AdcGroupTriggSrc: Continuous conversion mode only available for software triggered groups.		

<b>SWS Item</b>	<b>ADC398 :</b>		
<b>Name</b>	AdcGroupId {ADC_GROUP_ID}		
<b>Description</b>	Numeric ID of the group. This parameter is the symbolic name to be used on the API. This symbolic name allows accessing Channel Group data. This value will be assigned to the symbolic name derived of the AdcGroup container shortName. ImplementationType: Adc_GroupType		
<b>Multiplicity</b>	1		
<b>Type</b>	IntegerParamDef (Symbolic Name generated for this parameter)		
<b>Default value</b>	--		
<b>ConfigurationClass</b>	<b>Pre-compile time</b>	X	VARIANT-PRE-COMPILE
	<b>Link time</b>	--	
	<b>Post-build time</b>	M	VARIANT-POST-BUILD
<b>Scope / Dependency</b>	scope: Module		

<b>SWS Item</b>	<b>ADC287 :</b>		
<b>Name</b>	AdcGroupPriority {ADC_GROUP_PRIORITY}		
<b>Description</b>	Priority level of the AdcGroup. ImplementationType: Adc_GroupPriorityType		
<b>Multiplicity</b>	1		
<b>Type</b>	IntegerParamDef		
<b>Range</b>	0 .. 255		

<b>Default value</b>	--		
<b>ConfigurationClass</b>	<b>Pre-compile time</b>	X	VARIANT-PRE-COMPILE
	<b>Link time</b>	--	
	<b>Post-build time</b>	M	VARIANT-POST-BUILD
<b>Scope / Dependency</b>	dependency: ADC_PRIORITY_IMPLEMENTATION		

<b>SWS Item</b>	<b>ADC431 :</b>		
<b>Name</b>	AdcGroupReplacement {ADC_GROUP_REPLACEMENT}		
<b>Description</b>	Replacement mechanism, which is used on ADC group level, if a group conversion is interrupted by a group which has a higher priority. ImplementationType: Adc_GroupReplacementType		
<b>Multiplicity</b>	1		
<b>Type</b>	EnumerationParamDef		
<b>Range</b>	ADC_GROUP_REPL_ABORT_RESTART	Abort/Restart mechanism is used on group level, if a group is interrupted by a higher priority group. The complete conversion round of the interrupted group (all group channels) is restarted after the higher priority group conversion is finished. If the group is configured in streaming access mode, only the results of the interrupted conversion round are discarded. Results of previous conversion rounds which are already written to the result buffer are not affected.	
	ADC_GROUP_REPL_SUSPEND_RESUME	Suspend/Resume mechanism is used on group level, if a group is interrupted by a higher priority group. The conversions round of the interrupted group is completed after the higher priority group conversion is finished.	
<b>ConfigurationClass</b>	<b>Pre-compile time</b>	X	VARIANT-PRE-COMPILE
	<b>Link time</b>	--	
	<b>Post-build time</b>	M	VARIANT-POST-BUILD
<b>Scope / Dependency</b>	scope: Module		

<b>SWS Item</b>	<b>ADC399 :</b>		
<b>Name</b>	AdcGroupTriggSrc {ADC_GROUP_TRIGG_SRC}		
<b>Description</b>	Type of source event that starts a group conversion. ImplementationType: Adc_TriggerSourceType		
<b>Multiplicity</b>	1		
<b>Type</b>	EnumerationParamDef		
<b>Range</b>	ADC_TRIGG_SRC_HW	Group is triggered by a hardware event.	
	ADC_TRIGG_SRC_SW	Group is triggered by a software API call.	
<b>ConfigurationClass</b>	<b>Pre-compile time</b>	X	VARIANT-PRE-COMPILE
	<b>Link time</b>	--	

	<b>Post-build time</b>	M	VARIANT-POST-BUILD
<b>Scope / Dependency</b>	scope: Module dependency: AdcGroupConvMode: Trigger source HW is not available for continuous conversion mode.		

<b>SWS Item</b>	<b>ADC400 :</b>		
<b>Name</b>	AdcHwTrigSignal {ADC_HW_TRIG_SIGNAL}		
<b>Description</b>	Configures on which edge of the hardware trigger signal the driver should react, i.e. start the conversion (only if supported by the ADC hardware). ImplementationType: Adc_HwTriggerSignalType		
<b>Multiplicity</b>	1		
<b>Type</b>	EnumerationParamDef		
<b>Range</b>	ADC_HW_TRIG_BOTH_EDGES	React on both edges of the hardware trigger signal (only if supported by the ADC hardware).	
	ADC_HW_TRIG_FALLING_EDGE	React on the falling edge of the hardware trigger signal (only if supported by the ADC hardware).	
	ADC_HW_TRIG_RISING_EDGE	React on the rising edge of the hardware trigger signal (only if supported by the ADC hardware).	
<b>ConfigurationClass</b>	<b>Pre-compile time</b>	X	VARIANT-PRE-COMPILE
	<b>Link time</b>	--	
	<b>Post-build time</b>	M	VARIANT-POST-BUILD
<b>Scope / Dependency</b>	scope: Module dependency: AdcTriggSrcHw: Valid only if the group is configured to be triggered by a hardware event.		

<b>SWS Item</b>	<b>ADC401 :</b>		
<b>Name</b>	AdcHwTrigTimer {ADC_HW_TRIG_TIMER}		
<b>Description</b>	Reload value of the ADC module embedded timer (only if supported by ADC hardware). ImplementationType: Adc_HwTriggerTimerType		
<b>Multiplicity</b>	0..1		
<b>Type</b>	IntegerParamDef		
<b>Default value</b>	--		
<b>ConfigurationClass</b>	<b>Pre-compile time</b>	X	VARIANT-PRE-COMPILE
	<b>Link time</b>	--	
	<b>Post-build time</b>	M	VARIANT-POST-BUILD
<b>Scope / Dependency</b>	scope: Module dependency: AdcTriggSrcHw: Valid only if the group is configured to be triggered by a hardware event.		

<b>SWS Item</b>	<b>ADC402 :</b>		
<b>Name</b>	AdcNotification {ADC_NOTIFICATION}		
<b>Description</b>	Callback function for each group		
<b>Multiplicity</b>	0..1		
<b>Type</b>	FunctionNameDef		
<b>Default value</b>	--		
<b>ConfigurationClass</b>	<b>Pre-compile time</b>	X	VARIANT-PRE-COMPILE
	<b>Link time</b>	--	
	<b>Post-build time</b>	M	VARIANT-POST-BUILD
<b>Scope / Dependency</b>	scope: Module dependency: This parameter is only available, if notification capability is configured available by AdcGrpNotifCapability		

<b>SWS Item</b>	<b>ADC291 :</b>		
-----------------	-----------------	--	--

<b>Name</b>	AdcResultBufferPointer {ADC_RESULT_BUFFER_POINTER}		
<b>Description</b>	Pointer to data buffer (destination for conversion results). One pointer for each ADC group is required. In streaming access mode the Adc_ValueGroupType buffer is made of m*n elements, where n is the number of channels belonging to the group and m the number of samples acquired per channel (i.e. ADC_STREAMING_NUM_SAMPLES). In single access mode (m=1) the Adc_ValueGroupType buffer is made of n elements, where n is the number of channels belonging to the group. User has to ensure that the AdcResultBufferPointer of the ADC groups point to the base addresses of the ADC result buffer. ImplementationType: Adc_ValueGroupType *		
<b>Multiplicity</b>	0..1		
<b>Type</b>	LinkerSymbolDef		
<b>Default value</b>	--		
<b>ConfigurationClass</b>	<b>Pre-compile time</b>	X	VARIANT-PRE-COMPILE
	<b>Link time</b>	--	
	<b>Post-build time</b>	M	VARIANT-POST-BUILD
<b>Scope / Dependency</b>	scope: Module		

<b>SWS Item</b>	<b>ADC316 :</b>		
<b>Name</b>	AdcStreamingBufferMode {ADC_STREAMING_BUFFER_MODE}		
<b>Description</b>	Configure streaming buffer as "linear buffer" (i.e. the ADC Driver stops the conversion as soon as the stream buffer is full) or as "ring buffer" (wraps around if the end of the stream buffer is reached). ImplementationType: Adc_StreamBufferModeType		
<b>Multiplicity</b>	1		
<b>Type</b>	EnumerationParamDef		
<b>Range</b>	ADC_STREAM_BUFFER_CIRCULAR	The ADC Driver continues the conversion even if the stream buffer is full (number of samples reached) by wrapping around the stream buffer itself.	
	ADC_STREAM_BUFFER_LINEAR	The ADC Driver stops the conversion as soon as the stream buffer is full (number of samples reached).	
<b>ConfigurationClass</b>	<b>Pre-compile time</b>	X	VARIANT-PRE-COMPILE
	<b>Link time</b>	--	
	<b>Post-build time</b>	M	VARIANT-POST-BUILD
<b>Scope / Dependency</b>	scope: Module dependency: AdcGroupAccessMode: Valid only for streaming access mode.		

<b>SWS Item</b>	<b>ADC292 :</b>		
<b>Name</b>	AdcStreamingNumSamples {ADC_STREAMING_NUM_SAMPLES}		
<b>Description</b>	Number of ADC values to be acquired per channel in streaming access mode. Note: in single access mode this parameter assumes value 1, since only one sample per channel is processed. ImplementationType: Adc_StreamNumSampleType		
<b>Multiplicity</b>	1		
<b>Type</b>	IntegerParamDef		
<b>Default value</b>	1		
<b>ConfigurationClass</b>	<b>Pre-compile time</b>	X	VARIANT-PRE-COMPILE
	<b>Link time</b>	--	
	<b>Post-build time</b>	M	VARIANT-POST-BUILD
<b>Scope / Dependency</b>	scope: Module dependency: AdcGroupAccessMode: Valid only for streaming access mode. In single access mode this parameter assumes value 1, since only one sample per channel is processed.		

<b>SWS Item</b>	<b>ADC014 :</b>		
<b>Name</b>	AdcGroupDefinition {ADC_GROUP_DEFINITION}		
<b>Description</b>	Assignment of AdcChannels to a AdcGroups. ImplementationType: Adc_GroupDefType		
<b>Multiplicity</b>	0..*		
<b>Type</b>	Reference to AdcChannel		
<b>ConfigurationClass</b>	<b>Pre-compile time</b>	X	VARIANT-PRE-COMPILE
	<b>Link time</b>	--	
	<b>Post-build time</b>	M	VARIANT-POST-BUILD
<b>Scope / Dependency</b>	scope: Module		

<b>No Included Containers</b>
-------------------------------

**ADC098: (refers to ADC396):** All channels of a group share the same group configuration (channel can have different channel specific configurations).

### 10.2.7 AdcHwUnit

<b>SWS Item</b>	<b>ADC242 :</b>
<b>Container Name</b>	AdcHwUnit{AdcHWUnitConfiguration}
<b>Description</b>	This container contains the Driver configuration (parameters) depending on grouping of channels This container could contain HW specific parameters which are not defined in the Standardized Module Definition. They must be added in the Vendor Specific Module Definition.
<b>Configuration Parameters</b>	

<b>SWS Item</b>	<b>ADC087 :</b>		
<b>Name</b>	AdcClockSource {ADC_CLK_SRC}		
<b>Description</b>	The ADC module specific clock input for the conversion unit can statically be configured to select different clock sources if provided by hardware. ImplementationType: Adc_ClockSourceType		
<b>Multiplicity</b>	0..1		
<b>Type</b>	IntegerParamDef		
<b>Default value</b>	--		
<b>ConfigurationClass</b>	<b>Pre-compile time</b>	X	VARIANT-PRE-COMPILE
	<b>Link time</b>	--	
	<b>Post-build time</b>	M	VARIANT-POST-BUILD
<b>Scope / Dependency</b>	scope: Module		

<b>SWS Item</b>	<b>ADC389 :</b>		
<b>Name</b>	AdcHwUnitId {ADC_HWUNIT_ID}		
<b>Description</b>	Numeric ID of the HW Unit. This symbolic name allows accessing Hw Unit data. ImplementationType: Adc_HwUnitType		
<b>Multiplicity</b>	1		
<b>Type</b>	IntegerParamDef (Symbolic Name generated for this parameter)		
<b>Default value</b>	--		
<b>ConfigurationClass</b>	<b>Pre-compile time</b>	X	VARIANT-PRE-COMPILE
	<b>Link time</b>	--	
	<b>Post-build time</b>	M	VARIANT-POST-BUILD
<b>Scope / Dependency</b>	scope: Module		

<b>SWS Item</b>	<b>ADC088 :</b>		
<b>Name</b>	AdcPrescale {ADC_PRESCALE}		
<b>Description</b>	Optional ADC module specific clock prescale factor, if supported by hardware. ImplementationType: Adc_PrescaleType		
<b>Multiplicity</b>	0..1		
<b>Type</b>	IntegerParamDef		
<b>Default value</b>	--		
<b>ConfigurationClass</b>	<b>Pre-compile time</b>	X	VARIANT-PRE-COMPILE
	<b>Link time</b>	--	
	<b>Post-build time</b>	M	VARIANT-POST-BUILD
<b>Scope / Dependency</b>	scope: Module		

<b>Included Containers</b>		
<b>Container Name</b>	<b>Multiplicity</b>	<b>Scope / Dependency</b>
AdcChannel	1..*	This container contains the channel configuration (parameters) depending on the hardware capability. The organization of this data structure could contain dependencies to the microcontroller so this is left up to the implementer and its location is left up to the configuration. Note: Since a AdcChannel can be part of several AdcGroups, this container is not realized as a subcontainer of AdcGroup but instead as a subcontainer of AdcHwUnit.

AdcGroup	1..*	This container contains the Group configuration (parameters).
----------	------	---

**ADC138: (refers to ADC242):** The ADC Driver shall support one or several ADC HW Units of the same type. The selection of ADC HW Unit shall be done by the configuration container AdcHwUnit.

## 10.3 Published information

Published information contains data defined by the implementer of the SW module that does not change when the module is adapted (i.e. configured) to the actual HW/SW environment. It thus contains version and manufacturer information.

The standard common published information like

- vendorId (ADC\_VENDOR\_ID),
- moduleId (ADC\_MODULE\_ID),
- arMajorVersion (ADC\_AR\_MAJOR\_VERSION),
- arMinorVersion (ADC\_AR\_MINOR\_VERSION),
- arPatchVersion (ADC\_AR\_PATCH\_VERSION),
- swMajorVersion (ADC\_SW\_MAJOR\_VERSION),
- swMinorVersion (ADC\_SW\_MINOR\_VERSION),
- swPatchVersion (ADC\_SW\_PATCH\_VERSION),
- vendorApiInfix (ADC\_VENDOR\_API\_INFIX)

is provided in the BSW Module Description Template (see [12], Figure 4.1 and Figure 7.1). Additional published parameters are listed below if applicable for this module.

### 10.3.1 AdcPublishedInformation

<b>SWS Item</b>	<b>ADC030 :</b>
<b>Container Name</b>	AdcPublishedInformation
<b>Description</b>	Additional published parameters not covered by CommonPublishedInformation container. Note that these parameters do not have any configuration class setting, since they are published information.
<b>Configuration Parameters</b>	

<b>SWS Item</b>	<b>ADC410 :</b>
<b>Name</b>	AdcChannelValueSigned {ADC_CHANNEL_VALUESIGNED}
<b>Description</b>	Information whether the result value of the ADC driver has sign information (true) or not (false). If the result shall be interpreted as signed value it shall apply to C-language rules.
<b>Multiplicity</b>	1
<b>Type</b>	BooleanParamDef
<b>Default value</b>	--
<b>ConfigurationClass</b>	<b>Published Information</b>   X   All Variants
<b>Scope / Dependency</b>	

<b>SWS Item</b>	<b>ADC411 :</b>
<b>Name</b>	AdcGroupFirstChannelFixed {ADC_GROUP_FIRST_CHANNEL_FIXED}

<b>Description</b>	Information whether the first channel of an ADC Channel group can be configured (false) or is fixed (true) to a value determined by the ADC HW Unit.		
<b>Multiplicity</b>	1		
<b>Type</b>	BooleanParamDef		
<b>Default value</b>	--		
<b>ConfigurationClass</b>	<b>Published Information</b>	X	All Variants
<b>Scope / Dependency</b>			

<b>SWS Item</b>	<b>ADC412 :</b>		
<b>Name</b>	AdcMaxChannelResolution {ADC_MAX_CHANNEL_RESOLUTION}		
<b>Description</b>	Maximum Channel resolution in bits (does not specify accuracy).		
<b>Multiplicity</b>	1		
<b>Type</b>	IntegerParamDef		
<b>Default value</b>	--		
<b>ConfigurationClass</b>	<b>Published Information</b>	X	All Variants
<b>Scope / Dependency</b>			

**No Included Containers**

## 10.4 Configuration of symbolic names

**ADC099:** The symbolic names of ADC channels and ADC channel groups for use by the upper layer shall be defined by the configurator. They are to be defined in the modules configuration header file.



## 11 Changes to Release 1

### 11.1 Deleted SWS Items

<i>SWS Item</i>	<i>Rationale</i>
ADC029	According new template

### 11.2 Replaced SWS Items

<i>SWS Item of Release 1</i>	<i>replaced by SWS Item</i>	<i>Rationale</i>
ADC070	<a href="#">ADC233</a> , <a href="#">ADC234</a> , <a href="#">ADC235</a>	Required for new SWS template.
ADC148	<a href="#">ADC246</a> , <a href="#">ADC247</a> , <a href="#">ADC248</a> , <a href="#">ADC249</a> , <a href="#">ADC250</a>	New formulation for one-time writeable registers.
ADC076	ADC244	Standardization of default value.

### 11.3 Changed SWS Items

<i>SWS Item</i>	<i>Rationale</i>
<a href="#">ADC001</a>	Added stop functionality.
<a href="#">ADC030</a>	Take in account the new template for published information and BSW003.
<a href="#">ADC086</a> , <a href="#">ADC107</a> , <a href="#">ADC112</a> , <a href="#">ADC115</a> , <a href="#">ADC118</a> , <a href="#">ADC125</a> , <a href="#">ADC126</a> , <a href="#">ADC128</a> , <a href="#">ADC129</a> , <a href="#">ADC130</a> , <a href="#">ADC131</a> , <a href="#">ADC132</a> , <a href="#">ADC133</a> , <a href="#">ADC134</a> , <a href="#">ADC135</a> , <a href="#">ADC136</a> , <a href="#">ADC137</a> , <a href="#">ADC152</a> , <a href="#">ADC154</a>	Modified requirements to align statement for DET.
<a href="#">ADC112</a>	Clarified behavior of Adc_Deinit function when call occurs while conversion is running.
ADC108	Stop conversion depending by HW capability.
<a href="#">ADC087</a>	According to the new template.
<a href="#">ADC090</a>	Removed "Basic" definition.
<a href="#">ADC091</a>	Removed "Basic" definition.
<a href="#">ADC092</a>	Removed "Basic" definition.
ADC093	Removed "Basic" definition.
<a href="#">ADC027</a>	According to the new template.
<a href="#">ADC028</a>	According to the new template.
<a href="#">ADC138</a>	New Driver structure and functionalities.
ADC139	Split in different requirement IDs (see <a href="#">ADC253</a> ).
<a href="#">ADC140</a>	New Driver structure and functionalities.
<a href="#">ADC067</a>	According to the new template.
ADC150	Standardization of start-up code meaning.
<a href="#">ADC077</a>	New Driver structure and functionalities.
<a href="#">ADC110</a>	New formulation for shared registers.
<a href="#">ADC111</a>	Clarification of functional perimeter of the Adc_Deinit function.
ADC127	New Driver structure and functionalities.

<a href="#">ADC124</a>	New Driver structure and functionalities.
<a href="#">ADC113</a>	Standardization of result value.
<a href="#">ADC114</a>	New Driver structure and functionalities.
<a href="#">ADC144</a>	New Driver structure and functionalities.
<a href="#">ADC142</a>	New Driver structure and functionalities (Use of Adc_EnableHardwareTrigger to re-arm an internal timer).
<a href="#">ADC116</a>	New Driver structure and functionalities.
<a href="#">ADC145</a>	New Driver structure and functionalities.
<a href="#">ADC023</a>	#4619 (Rfc#4198).
<a href="#">ADC089</a>	#4619 (Rfc#4198).
<a href="#">ADC095</a>	Notification capability corrected in hardware capability.
<a href="#">ADC096</a>	Notification capability corrected in hardware capability.
<a href="#">ADC098</a>	#4200: clarified definition of group configuration.

## 11.4 Added SWS Items

<i>SWS Item</i>	<i>Rationale</i>
<a href="#">ADC155</a>	Added to substitute wrong duplicated ID in SWS ADC 1.0 ( <a href="#">ADC124</a> ).
<a href="#">ADC156</a>	Added to substitute wrong duplicated ID in SWS ADC 1.0 ( <a href="#">ADC125</a> ).
<a href="#">ADC157</a>	Added to substitute wrong duplicated ID in SWS ADC 1.0 ( <a href="#">ADC126</a> ).
<a href="#">ADC158</a>	Added to substitute wrong duplicated ID in SWS ADC 1.0 ( <a href="#">ADC128</a> ).
<a href="#">ADC159</a>	Added to substitute wrong duplicated ID in SWS ADC 1.0 ( <a href="#">ADC129</a> ).
<a href="#">ADC160</a>	Added to substitute wrong duplicated ID in SWS ADC 1.0 ( <a href="#">ADC130</a> ).
<a href="#">ADC161</a>	Added to substitute wrong duplicated ID in SWS ADC 1.0 ( <a href="#">ADC131</a> ).
<a href="#">ADC162</a>	Added to substitute wrong duplicated ID in SWS ADC 1.0 ( <a href="#">ADC132</a> ).
<a href="#">ADC163</a>	Added to substitute wrong duplicated ID in SWS ADC 1.0 ( <a href="#">ADC138</a> ).
<a href="#">ADC164</a>	#4191.
<a href="#">ADC165</a>	#4194.
<a href="#">ADC166</a>	#4194.
<a href="#">ADC167</a>	New Driver structure and functionalities.
<a href="#">ADC168</a>	#4192.
<a href="#">ADC169</a>	New Driver structure and functionalities.
<a href="#">ADC174</a>	New Driver structure and functionalities.
<a href="#">ADC175</a>	New DET error.
<a href="#">ADC176</a>	New DET error.
<a href="#">ADC177</a>	New Driver structure and functionalities.
<a href="#">ADC179</a>	New Driver structure and functionalities.
<a href="#">ADC180</a>	New Driver structure and functionalities.
<a href="#">ADC181</a>	New Driver structure and functionalities.
<a href="#">ADC182</a>	New Driver structure and functionalities.
<a href="#">ADC183</a>	New Driver structure and functionalities.
<a href="#">ADC184</a>	New DET error.
<a href="#">ADC185</a>	New DET error.
<a href="#">ADC186</a>	New Driver structure and functionalities.
<a href="#">ADC187</a>	New Driver structure and functionalities.
<a href="#">ADC188</a>	New Driver structure and functionalities.
<a href="#">ADC189</a>	New Driver structure and functionalities.
<a href="#">ADC190</a>	New Driver structure and functionalities.
<a href="#">ADC191</a>	New Driver structure and functionalities.
<a href="#">ADC192</a>	New Driver structure and functionalities.
<a href="#">ADC193</a>	New DET error.
<a href="#">ADC194</a>	New Driver structure and functionalities.
<a href="#">ADC195</a>	New Driver structure and functionalities.
<a href="#">ADC196</a>	New Driver structure and functionalities.
<a href="#">ADC197</a>	New Driver structure and functionalities.
<a href="#">ADC198</a>	New Driver structure and functionalities.

ADC199	New Driver structure and functionalities.
ADC200	New Driver structure and functionalities.
ADC201	New Driver structure and functionalities.
ADC202	New Driver structure and functionalities.
ADC203	New Driver structure and functionalities.
ADC204	New Driver structure and functionalities.
ADC205	New Driver structure and functionalities.
ADC206	New Driver structure and functionalities.
ADC207	New Driver structure and functionalities.
ADC208	New DET error.
ADC209	New DET error.
ADC210	New Driver structure and functionalities.
ADC211	New Driver structure and functionalities.
ADC212	New DET error.
ADC213	New Driver structure and functionalities.
<a href="#">ADC214</a>	New Driver structure and functionalities.
<a href="#">ADC215</a>	New Driver structure and functionalities.
<a href="#">ADC216</a>	New Driver structure and functionalities.
ADC217	New Driver structure and functionalities.
<a href="#">ADC218</a>	New DET error.
<a href="#">ADC219</a>	New Driver structure and functionalities.
<a href="#">ADC220</a>	New Driver structure and functionalities.
<a href="#">ADC221</a>	New Driver structure and functionalities.
<a href="#">ADC222</a>	New Driver structure and functionalities.
ADC223	New Driver structure and functionalities.
<a href="#">ADC224</a>	New Driver structure and functionalities.
<a href="#">ADC225</a>	New DET error.
<a href="#">ADC226</a>	New Driver structure and functionalities.
<a href="#">ADC228</a>	Required for new SWS template (API pre compile time configurable On/Off).
<a href="#">ADC229</a> , <a href="#">ADC230</a> , <a href="#">ADC233</a> , <a href="#">ADC234</a> , <a href="#">ADC235</a> , <a href="#">ADC236</a> , <a href="#">ADC237</a> , <a href="#">ADC238</a> , <a href="#">ADC239</a> , <a href="#">ADC240</a>	Required for new SWS template.
<a href="#">ADC241</a>	Missed DET error.
<a href="#">ADC242</a>	Required for new SWS template.
ADC243	Configuration check.
ADC244	Missing requirements: description already present but not tagged as requirement IDs.
<a href="#">ADC246</a> , <a href="#">ADC247</a> , <a href="#">ADC248</a> , <a href="#">ADC249</a> , <a href="#">ADC250</a>	Modified according <b>BSW12461</b> .
<del>ADC251</del> , <del>ADC380</del> , <del>ADC381</del> , <del>ADC252</del> , <del>ADC382</del> , <del>ADC383</del> , <del>ADC253</del> , <del>ADC356</del> , <del>ADC357</del> , <a href="#">ADC254</a> , <del>ADC255</del> , <del>ADC256</del> , <del>ADC257</del> , <del>ADC258</del> ,	Missing requirements: description already present but not tagged as requirement IDs.
<a href="#">ADC259</a> , <a href="#">ADC260</a> , <del>ADC261</del> , <del>ADC262</del> , <del>ADC263</del> , <del>ADC264</del> , <a href="#">ADC265</a> , <a href="#">ADC266</a>	Required for new SWS template (API pre compile time configurable On/Off).
<a href="#">ADC267</a> , <a href="#">ADC268</a> , <a href="#">ADC269</a> , <a href="#">ADC270</a> , <del>ADC271</del>	Missing requirements: description already present but not tagged as requirement IDs.
ADC272	Constrains on Adc_EnableHardwareTrigger function.

<a href="#">ADC273</a>	Constrains on Adc_EnableHardwareTrigger function.
<b>ADC274</b>	Handling of multiple HW trigger for gated conversion.
<a href="#">ADC275</a>	Added (SPAL decision, 41st meeting, minutes day2, issue 5).

## 12 Changes to Release 2.0.0

### 12.1 Deleted SWS Items

<i>SWS Item</i>	<i>Rationale</i>
ADC093	Superfluous specification element.
ADC163	Superfluous specification element.
ADC139	Superfluous specification element.
ADC167	On demand conversion not supported.
ADC256	On demand conversion not supported.
ADC257	Gated continuous conversion not supported.
ADC177	Gated continuous conversion not supported.
ADC132	NULL-pointer check removed from Adc_Init function.
ADC168	Check should be done offline by configuration tool (too much overhead).
ADC243	On demand conversion not supported.
ADC086	Check should be done offline by configuration tool (too much overhead).
ADC127	No concurrency supported, no re-entrance capabilities needed.
ADC158	No concurrency supported, no re-entrance capabilities needed.
ADC106	Superfluous specification element.
ADC244	“out of range” can’t be supported by an ADC Driver.
ADC142	Superfluous and confusing.
ADC272	No concurrency supported, no check needed.
ADC159	No concurrency supported, no re-entrance capabilities needed.
ADC143	Superfluous specification element.
ADC134	Superfluous check (functionality shall be configured out).
ADC161	No concurrency supported, no re-entrance capabilities needed.
ADC135	Superfluous check (functionality shall be configured out).
ADC162	No concurrency supported, no re-entrance capabilities needed.
ADC223	Adc_GroupStatusType reworked, specification element now obsolete.
ADC119	Superfluous (after reformulation of the item).
ADC096	No distinction between internal and external HW trigger source.
ADC195	On demand conversion not supported.
ADC196	Gated continuous conversion not supported.
ADC109	Integrated with ADC110 as requested in bugzilla issue #11903.

### 12.2 Replaced SWS Items

<i>SWS Item of Release 1</i>	<i>replaced by SWS Item</i>	<i>Rationale</i>
ADC115	<a href="#">ADC281</a>	Similar content, different formulation.
ADC118	<a href="#">ADC282</a>	Similar content, different formulation.

### 12.3 Changed SWS Items

<i>SWS Item</i>	<i>Rationale</i>
<a href="#">ADC090</a>	Split into two requirements (added <a href="#">ADC279</a> for second part).
<a href="#">ADC251</a>	On demand and gated continuous conversion deleted, descriptions for one-shot and continuous conversion reformulated.
<a href="#">ADC252</a>	Streaming result access mode deleted.
<a href="#">ADC253</a>	Reformulated (conversion trigger sources).
<a href="#">ADC140</a>	Reformulated (data consistency).
<a href="#">ADC254</a>	Reformulated.

<b>ADC255</b>	Reformulated (no concurrency).
<a href="#">ADC124</a>	Reformulated according to BSW004 (SRS General).
<a href="#">ADC065</a>	Deleted second part (contained in <a href="#">ADC233</a> ).
<b>ADC108</b>	Reformulated (in the hope to make it more clear).
<a href="#">ADC241</a>	Error code changed to make it distinguishable from other errors.
<a href="#">ADC120</a>	Reformulated (trigger source).
<a href="#">ADC145</a>	Reformulated (for all supported conversion modes).
<a href="#">ADC157</a>	Reformulated to adapt to <a href="#">ADC155</a> .
<a href="#">ADC121</a>	Reformulated (trigger source).
<a href="#">ADC275</a>	Reformulated /after BSW00414 had been reformulated).
<a href="#">ADC014</a> , <a href="#">ADC098</a>	Group definition configuration changed.

## 12.4 Added SWS Items

<i>SWS Item</i>	<i>Rationale</i>
<b>ADC276</b>	Added for stripped down SWS version.
<a href="#">ADC277</a>	Added for stripped down SWS version.
<b>ADC278</b>	Added for stripped down SWS version.
<a href="#">ADC279</a>	Added for stripped down SWS version.
<a href="#">ADC280</a>	Added for stripped down SWS version.
<a href="#">ADC283</a>	Added (analogue to <a href="#">ADC146</a> ).
<b>ADC284</b> , <b>ADC285</b>	Added (replacement for former group definition configuration).
<a href="#">ADC286</a>	Added for stripped down SWS version.

## 13 Changes to Release 2.0.1

### 13.1 Deleted SWS Items

<i>SWS Item</i>	<i>Rationale</i>
ADC278	A corresponding requirement doesn't exist.
ADC108	Superfluous specification element.
ADC284	No more needed: changed the way to assign channels are to groups.
ADC285	No more needed: changed the way to assign channels are to groups.
ADC109	Integrated with ADC110 as requested in bugzilla issue #11903.
ADC150, ADC151, ADC147	Redundant to <a href="#">ADC246</a> , <a href="#">ADC247</a> , <a href="#">ADC248</a> , <a href="#">ADC249</a> , <a href="#">ADC250</a>
ADC213	The relevant information is given in ADC214.

### 13.2 Replaced SWS Items

<i>SWS Item of Release 1</i>	<i>replaced by SWS Item</i>	<i>Rationale</i>

### 13.3 Changed SWS Items

<i>SWS Item</i>	<i>Rationale</i>
<a href="#">ADC252</a>	Streaming result access mode added.
<a href="#">ADC075</a>	Adapted to channel group concept.
<a href="#">ADC113</a>	Adapted to channel group concept.
<a href="#">ADC122</a>	Adapted to channel group concept.
<a href="#">ADC027</a>	Added parameter ADC_GRP_PRIORITY_INP_LEVEL.
<a href="#">ADC011</a>	Slightly reformulated.
<a href="#">ADC061</a>	Slightly reformulated.
<a href="#">ADC276</a>	Slightly reformulated to cover some Bugzilla entries.
<a href="#">ADC222</a>	Slightly reformulated to cover some Bugzilla entries.
<a href="#">ADC224</a>	Slightly reformulated to cover some Bugzilla entries.

### 13.4 Added SWS Items

<i>SWS Item</i>	<i>Rationale</i>
<a href="#">ADC288</a>	Added for channel group priority mechanism.
<a href="#">ADC289</a>	Added for channel group priority mechanism.
<a href="#">ADC214</a>	Added for new service Adc_GetStreamLastPointer.
<a href="#">ADC215</a>	Added for new service Adc_GetStreamLastPointer.
<a href="#">ADC216</a>	Added for new service Adc_GetStreamLastPointer.
<a href="#">ADC217</a>	Added for new service Adc_GetStreamLastPointer.
<a href="#">ADC218</a>	Added for new service Adc_GetStreamLastPointer.
<a href="#">ADC219</a>	Added for new service Adc_GetStreamLastPointer.
<a href="#">ADC287</a>	Added for channel group priority mechanism.
<a href="#">ADC291</a>	Added for streaming access mode.
<a href="#">ADC292</a>	Added for streaming access mode.
<a href="#">ADC290</a>	Added sampling time parameter.

<a href="#">ADC154</a> , <a href="#">ADC294</a> , <a href="#">ADC295</a> , <a href="#">ADC296</a> , <a href="#">ADC297</a> , <a href="#">ADC298</a> , <a href="#">ADC299</a> , <a href="#">ADC300</a> , <a href="#">ADC301</a> , <a href="#">ADC302</a>	Added development error DET_ADC_E_UNINIT
<del>ADC303</del>	Added to API Adc_StopGroupConversion.
<a href="#">ADC304</a>	Added to API Adc_DisableHardwareTrigger.
<a href="#">ADC305</a>	Added to API GetGroupStatus
<del>ADC306</del>	Added to API Adc_EnableHardwareTrigger to cover some Bugzilla entries.
<a href="#">ADC307</a>	Added to API Adc_GetGroupStatus to cover some Bugzilla entries.
<del>ADC308</del>	Added to API Adc_GetGroupStatus to cover some Bugzilla entries.
<del>ADC309</del>	Added for channel group priority mechanism.
<a href="#">ADC310</a>	Added for channel group priority mechanism.
<a href="#">ADC311</a>	Added for channel group priority mechanism.
<a href="#">ADC312</a>	Added for channel group priority mechanism.
<del>ADC314</del>	Added for channel group priority mechanism.
<a href="#">ADC315</a>	Added for channel group priority mechanism.
<a href="#">ADC316</a>	Added for streaming access mode.
<a href="#">ADC317</a>	Added for streaming access mode.
<a href="#">ADC318</a>	Added for specifying the return value structure.
<a href="#">ADC319</a>	Added for specifying the return value structure.
<a href="#">ADC320</a>	Added for specifying the return value structure.



## 14 Changes to Release 2.1.1

### 14.1 Deleted SWS Items

SWS Item	Rationale
ADC217	Pointer is only modified if the Adc_GetStreamLastPointer is called
ADC323	Condition contained in ADC349

### 14.2 Replaced SWS Items

SWS Item of Release 1	replaced by SWS Item	Rationale
ADC306	ADC321, ADC322, ADC323	Differentiation between priority mechanism enabled/disabled and queuing on/off
ADC314	ADC339	All priority configuration levels 0-255 are available. If HW prioritization mechanism is supported, driver shall map configuration levels to hardware priority levels.
ADC309	ADC332,ADC333,ADC334, ADC335,ADC336,ADC337, ADC338	Split in atomic requirements; a group can only be queued one time; queuing of HW groups handled by HW
ADC276	ADC346,ADC347,ADC348	Change of ADC_E_BUSY development error specification for Adc_StartGroupConversion

### 14.3 Changed SWS Items

SWS Item	Rationale
<a href="#">ADC107</a>	New DET defined for initialization with ADC_Init while ADC is already initialized
<a href="#">ADC301</a>	Specify return value for ADC_GetGroupStatus in case of DET
<a href="#">ADC225</a>	Specify return value for ADC_GetGroupStatus in case of DET
ADC214, ADC216, ADC236	Change 'return' to 'read'
ADC215,	
ADC218	Specify return value and return pointer value in case of DET
ADC302	Specify return value and return pointer value in case of DET
ADC320	Change 'the group' to 'any group'
ADC304	Change DET ADC_E_PARAM_GROUP to ADC_E_IDLE
ADC216	Reformulated
ADC239	Optional inclusion of dem.h
ADC224	Modified, no ADC_COMPLETED after completion of one-shot conversion
ADC221	Added conditions for ADC_IDLE group status
ADC222	Added conditions for ADC_COMPLETED group status
ADC241	DET ADC_E_IDLE in Adc_StopGroup only for modes which don't stop conversion automatically
ADC252	Single value result access mode removed – group access mode introduced
ADC315	Split in ADC315 and ADC333
ADC054	Added PB variant condition
ADC214	reformulated
ADC310	Suspend/resume removed from ADC310 and shifted to ADC345

## 14.4 Added SWS Items

<b>SWS Item</b>	<b>Rationale</b>
<b>ADC324</b>	DET in Adc_GetVersionInfo if no previous initialization
<b>ADC325</b>	Adc_GetGroupStatus: condition for ADC_STREAM_COMPLETED
<b>ADC326</b>	Adc_GetStreamLastPointer: State transition ADC_STREAM_COMPLETED to ADC_BUSY
<b>ADC327</b>	Adc_GetStreamLastPointer: State transition ADC_STREAM_COMPLETED to ADC_IDLE
<b>ADC328</b>	Adc_GetStreamLastPointer: State Transition ADC_COMPLETED to ADC_BUSY
<b>ADC329</b>	Adc_ReadGroup: State transition ADC_STREAM_COMPLETED to ADC_BUSY
<b>ADC330</b>	Adc_ReadGroup: State transition ADC_STREAM_COMPLETED to ADC_IDLE
<b>ADC331</b>	Adc_ReadGroup: State Transition ADC_COMPLETED to ADC_BUSY
<b>ADC340</b>	Static configuration option for SW/HW prioritization mechanism
<b>ADC341</b>	Static configuration option for HW prioritization mechanism
<b>ADC342</b>	Adc_Init configuration pointer in variant PC
<b>ADC343</b>	DET error for Adc_Init if configuration pointer is NULL_PTR in variant PB
<b>ADC344</b>	DET error for Adc_Init if configuration pointer is not NULL_PTR in variant PC
<b>ADC345</b>	suspend/resume optional
<b>ADC349</b>	ADC_E_BUSY if Adc_EnableHardwareTrigger is called for same group
<b>ADC350</b>	Prio enabled: ADC_E_BUSY if Adc_StartGroupConversion is called while the same group is already in conversion
<b>ADC351, ADC352</b>	Prio disabled, queuing on: ADC_E_BUSY if Adc_StartGroupConversion is called while the same group is already in conversion or stored in queue
<b>ADC353</b>	DET ADC_E_BUSY in Adc_EnableHardwareTrigger if maximum number of available HW trigger is already enabled

## 15 Changes during SWS Improvements by Technical Office

### 15.1 Deleted SWS Items

<i>SWS Item</i>	<i>Rationale</i>
ADC308	same as ADC360 / ADC361

### 15.2 Replaced SWS Items

<i>SWS Item of Release 1</i>	<i>replaced SWS Item</i>	<i>by</i>	<i>Rationale</i>
ADC253	<a href="#">ADC356</a> , <a href="#">ADC357</a>		Made requirement atomic
ADC251	<a href="#">ADC380</a> , <a href="#">ADC381</a>		Made requirement atomic
ADC252	<a href="#">ADC382</a> , <a href="#">ADC383</a>		Made requirement atomic
ADC072, ADC303	<a href="#">ADC385</a> , <a href="#">ADC386</a>		Made requirements atomic

### 15.3 Changed SWS Item

Many requirements have been changed to improve understandability without changing the technical contents.

### 15.4 Added SWS Items

<i>SWS Item</i>	<i>Rationale</i>
<a href="#">ADC354</a>	Requirement for the ADC module
<a href="#">ADC355</a>	Requirement for the ADC module
<a href="#">ADC356</a>	Requirement for the ADC module
<a href="#">ADC357</a>	Requirement for the ADC module
<a href="#">ADC358</a>	Requirement for the ADC module's environment
<a href="#">ADC359</a>	Requirement for the function <code>Adc_ReadGroup</code>
<a href="#">ADC360</a>	Requirement for the function <code>Adc_StopGroupConversion</code>
<a href="#">ADC361</a>	Requirement for the function <code>Adc_DisableHardwareTrigger</code>
<a href="#">ADC362</a>	Each variant gets an individual requirement ID
<a href="#">ADC363</a>	Each variant gets an individual requirement ID
<a href="#">ADC364</a>	UML model linking of the imported types
<a href="#">ADC365</a>	UML model linking of the function <code>Adc_Init</code>
<a href="#">ADC366</a>	UML model linking of the function <code>Adc_DeInit</code>
<a href="#">ADC367</a>	UML model linking of the function <code>Adc_StartGroupConversion</code>
<a href="#">ADC368</a>	UML model linking of the function <code>Adc_StopGroupConversion</code>
<a href="#">ADC369</a>	UML model linking of the function <code>Adc_ReadGroup</code>
<a href="#">ADC370</a>	UML model linking of the function <code>Adc_EnableHardwareTrigger</code>
<a href="#">ADC371</a>	UML model linking of the function <code>Adc_DisableHardwareTrigger</code>
<a href="#">ADC372</a>	UML model linking of the function <code>Adc_EnableGroupNotification</code>
<a href="#">ADC373</a>	UML model linking of the function <code>Adc_DisableGroupNotification</code>
<a href="#">ADC374</a>	UML model linking of the function <code>Adc_GetGroupStatus</code>
<a href="#">ADC375</a>	UML model linking of the function <code>Adc_GetStreamLastPointer</code>
<a href="#">ADC376</a>	UML model linking of the function <code>Adc_GetVersionInfo</code>
<a href="#">ADC377</a>	UML model linking of the optional interfaces
<a href="#">ADC379</a>	Gave an ID to an existing requirement
<a href="#">ADC384</a>	Gave an ID to an existing requirement

## 16 Changes to Release 2.1.3

### 16.1 Deleted SWS Items

<b>SWS Item</b>	<b>Rationale</b>
ADC347	ADC346 and ADC347 combined in modified ADC346
ADC322	ADC321 and ADC322 combined in modified ADC321
ADC334	Changed ADC334 to note
ADC254, ADC255	Changed ADC254 and ADC255 to note
ADC141	No OS interaction allowed
ADC270	Handeled in ADC082
ADC081	Handeled in ADC104
ADC079	Handeled in ADC085
ADC275	Handeled in ADC054 and ADC342
ADC094, ADC095	Handeled in ADC399
ADC001, ADC002	Handeled in ADC397
ADC350	Handeled in modified ADC348 – note added
ADC352	Handeled in modified ADC351 – note added

### 16.2 Replaced SWS Items

<b>SWS Item of Release 1</b>	<b>replaced by SWS Item</b>	<b>Rationale</b>

### 16.3 Changed SWS Item

<b>SWS Item</b>	<b>Rationale</b>
ADC346	DET condition depending on group state
ADC321	DET condition depending on group state
ADC144, ADC145	reformulated
ADC226	Reformulated – no OS interaction allowed
ADC241	Reformulated – state based; note added
ADC218, ADC302	Reformulated
ADC215	Reformulated – state based plus DET
ADC216	Reformulated – state based
ADC084	Reformulated
ADC240	Remove link time configuration parameter file
ADC146	Reformulated
ADC283	Reformulated
ADC219	Reformulated
ADC381	Reformulated – continuous conversion only for SW triggered groups
ADC358, ADC112	Reformulated – state based
ADC273	Note extended
ADC281, ADC282	Note added

**16.4 Added SWS Items**

<b><i>SWS Item</i></b>	<b><i>Rationale</i></b>
ADC387	Return value of Adc_GetStreamLastPointer
ADC388	DET ADC_E_IDLE in Adc_ReadGroup
ADC389-ADC412	New requirement ID's based on meta model update
ADC413-ADC415	Re-entrant functions listed; re-entrancy restrictions if same ADC group is used

## 17 Changes to Release 2.1.4

### 17.1 Deleted SWS Items

<i>SWS Item</i>	<i>Rationale</i>
ADC153	Changed to note – user responsibility

### 17.2 Replaced SWS Items

<i>SWS Item of Release 1</i>	<i>replaced SWS Item</i>	<i>by</i>	<i>Rationale</i>

### 17.3 Changed SWS Item

<i>SWS Item</i>	<i>Rationale</i>
ADC083	ADC083 split in atomic requirements ADC083 and ADC416
ADC355	
ADC240	Minor modification
ADC239	Split in requirement and note
ADC335	Reformulated requirement
ADC413,ADC414, ADC415, ADC321	Reformulated requirement
ADC342	
ADC288	Split in requirement and note
ADC310	Change to group specific requirement
ADC345	Change to group specific requirement
ADC339	'shall map' changed to 'shall allow mapping'
ADC332	Extend requirement
ADC385	Extend requirement
ADC386	Extend requirement
ADC112	No DET of implicitly stopped groups if state is ADC_STREAM_COMPLETED
ADC358, ADC241, ADC221, ADC224	Minor modification

### 17.4 Added SWS Items

<i>SWS Item</i>	<i>Rationale</i>
ADC416	ADC083 split in atomic requirements ADC083 and ADC416
ADC417	First come first served mechanism for groups on same priority level
ADC418	Changed note from ADC214 to requirement – format of data in result buffer
ADC419-ADC423	Requirements for new API Adc_Setup
ADC424	DET requirement for Adc_StartGroupConversion if result buffer is not initialized
ADC425	DET requirement for Adc_EnableHardwareTrigger if result buffer is not initialized
ADC426,ADC427, ADC428	DET requirements for Adc_StartGroupConversion for implicitly stopped groups
ADC429	Adc_DisableHardwareTrigger removal of any queued requests
ADC430	New group specific configuration parameter for group replacement mech.
ADC431, ADC432	Starting the group resets the internal group result buffer pointer