

Document Title	Specification of Generic Network Management Interface
Document Owner	AUTOSAR
Document Responsibility	AUTOSAR
Document Identification No	228
Document Classification	Standard

Document Version	1.1.0
Document Status	Final
Part of Release	3.0
Revision	7

Document Change History			
Date	Version	Changed by	Change Description
10.09.2010	1.1.0	AUTOSAR Administration	<ul style="list-style-type: none">• Fix of description of Nm_State_Notification• Legal disclaimer revised
03.12.2007	1.0.0	AUTOSAR Administration	Initial release

Disclaimer

This specification and the material contained in it, as released by AUTOSAR is for the purpose of information only. AUTOSAR and the companies that have contributed to it shall not be liable for any use of the specification.

The material contained in this specification is protected by copyright and other types of Intellectual Property Rights. The commercial exploitation of the material contained in this specification requires a license to such Intellectual Property Rights.

This specification may be utilized or reproduced without any modification, in any form or by any means, for informational purposes only.
For any other purpose, no part of the specification may be utilized or reproduced, in any form or by any means, without permission in writing from the publisher.

The AUTOSAR specifications have been developed for automotive applications only. They have neither been developed, nor tested for non-automotive applications.

The word AUTOSAR and the AUTOSAR logo are registered trademarks.

Advice for users

AUTOSAR Specification Documents may contain exemplary items (exemplary reference models, "use cases", and/or references to exemplary technical solutions, devices, processes or software).

Any such exemplary items are contained in the Specification Documents for illustration purposes only, and they themselves are not part of the AUTOSAR Standard. Neither their presence in such Specification Documents, nor any later documentation of AUTOSAR conformance of products actually implementing such exemplary items, imply that intellectual property rights covering such exemplary items are licensed under the same rules as applicable to the AUTOSAR Standard.

Table of Contents

1	Introduction and functional overview	5
2	Acronyms and abbreviations.....	6
3	Related documentation	7
3.1	Input documents.....	7
3.2	Related standards and norms	7
4	Constraints and assumptions.....	8
4.1	Limitations	8
4.2	Specific limitations of the coordinator functionality for AUTOSAR release 38	
4.3	Applicability to car domains.....	9
5	Dependencies to other modules	10
5.1	Interfaces to modules	10
5.1.1	ComM, CanNm, FrNm, LinNm	10
5.1.2	DET, DEM	11
5.1.3	BSW Scheduler	12
5.2	File structure	12
5.2.1	Code file structure	12
5.2.2	Header file structure	12
6	Requirements traceability	14
7	Functional specification.....	18
7.1	Base functionality	18
7.2	NM coordinator functionality	18
7.3	Error classification	21
7.4	Error detection.....	21
7.5	Error notification	21
8	API specification	22
8.1	Imported types.....	22
8.2	Type definitions	22
8.2.1	Nm_ReturnType	22
8.2.2	Nm_ModeType	22
8.2.3	Nm_StateType	22
8.2.4	Nm_BusNmType	23
8.2.5	Nm_BusNm_ConfigType.....	23
8.3	Function definitions	23
8.3.1	Services provided by NM Interface.....	23
8.3.1.1	Nm_Init	23
8.3.1.2	Nm_PassiveStartUp	24
8.3.1.3	Nm_NetworkRequest	24
8.3.1.4	Nm_NetworkRelease.....	25
8.3.1.5	Nm_DisableCommunication	25
8.3.1.6	Nm_EnableCommunication	26
8.3.1.7	Nm_SetUserData	27

8.3.1.8	Nm_GetUserData	27
8.3.1.9	Nm_GetPduData	28
8.3.1.10	Nm_RepeatMessageRequest.....	28
8.3.1.11	Nm_GetNodeIdentifier	29
8.3.1.12	Nm_GetLocalNodeIdentifier	30
8.3.1.13	Nm_CheckRemoteSleepIndication	30
8.3.1.14	Nm_GetState.....	31
8.3.1.15	Nm_GetVersionInfo	31
8.4	Call-back notifications	32
8.4.1	Nm_NetworkStartIndication	32
8.4.2	Nm_NetworkMode.....	33
8.4.3	Nm_PrepareBusSleepMode	33
8.4.4	Nm_BusSleepMode.....	33
8.4.5	Nm_PduRxIndication.....	34
8.4.6	Nm_StateChangeNotification	34
8.5	Scheduled functions	35
8.5.1	Nm_MainFunction	35
8.6	Expected Interfaces.....	35
8.6.1	Mandatory Interfaces.....	35
9	Sequence diagrams	37
10	Configuration specification	39
10.1	How to read this chapter	39
10.1.1	Configuration and configuration parameters.....	39
10.1.2	Variants	39
10.1.3	Containers	40
10.2	Containers and configuration parameters	40
10.2.1	Variants	40
10.2.2	Nm.....	40
10.2.3	NmGlobalConfig	41
10.2.4	NmChannelConfig	45
10.3	Published Information.....	46
11	Changes to Release 1	48
11.1	Deleted SWS Items	48
11.2	Replaced SWS Items	48
11.3	Changed SWS Items.....	48
11.4	Added SWS Items	48
12	Changes during SWS Improvements by Technical Office	49
12.1	Deleted SWS Items	49
12.2	Replaced SWS Items	49
12.3	Changed SWS Items.....	49
12.4	Added SWS Items	49

1 Introduction and functional overview

This document describes the concept, interfaces and configuration of the Generic Network Management Interface module.

The Generic Network Management Interface is an adaptation layer between the AUTOSAR Communication Manager and the AUTOSAR Bus specific network management modules (e.g. CAN Network Management or FlexRay Network Management)

Additionally, this document describes the interoperability between several networks connected to the same (coordinator) ECU that run AUTOSAR NM, where 'interoperability' means that these networks can be put to sleep synchronously. This functionality is also referred to as 'NM coordinator'. As an extension, some of the networks in question can be direct OSEK NM (ISO 17356-5) (see [9]).

Support of the NM coordinator functionality is optional. An AUTOSAR NM Interface implementation can either support:

- NM Interface functionality without any NM coordinator functionality
- NM Interface functionality with NM coordinator functionality limited to support synchronous shutdown of busses with AUTOSAR NM running on the busses
- NM Interface functionality with NM coordinator functionality to support synchronous shutdown of busses with AUTOSAR NM and direct OSEK NM running on the busses

2 Acronyms and abbreviations

Acronym:	Description:
CC	Communication Controller
NM	Network Management

Abbreviation:	Description:
CanIf	CAN Interface
CanNm	CAN NM
ComM	Communication Manager
EcuM	ECU State Manager
DEM	Diagnostic Event Manager
DET	Development Error Tracer

Term:	Definition:
Bus-Sleep Mode	Network mode where all interconnected communication controllers are in the sleep mode.
NM-Channel	Logical channel associated with the NM-cluster
NM-Cluster	Set of NM nodes coordinated with use of the NM algorithm
NM-Message	Packet of information exchanged for purposes of the NM algorithm.
NM-Timeout	Timeout in the NM algorithm that initiates transition into Bus-Sleep Mode.
NM User Data	Supplementary application specific piece of data that is attached to every NM message sent on the bus.
Node Identifier	Node address information exchanged for purposes of the NM algorithm.
Node Identifier List	List of Node Identifiers recognized by the NM algorithm.

3 Related documentation

3.1 Input documents

- [1] AUTOSAR Layered Software Architecture
AUTOSAR_SoftwareArchitecture.pdf
- [2] AUTOSAR Requirements on Basic Software Modules
AUTOSAR_SRS_General.pdf
- [3] AUTOSAR Requirements on Basic Software, Module NM
AUTOSAR_SRS_NM.pdf
- [4] AUTOSAR Software Specification of CAN Generic Network Management,
AUTOSAR_SWS_CAN_NM.pdf
- [5] AUTOSAR Software Specification of FlexRay Network Management
AUTOSAR_SWS_FlexRay_NM.pdf
- [6] AUTOSAR Software Specification of Module Communication Manager
AUTOSAR_SWS_ComManager.pdf
- [7] AUTOSAR Software Specification of Module ECU State Manager
AUTOSAR_SWS_EcuStateManager.pdf
- [8] AUTOSAR Basic Software Module Description Template,
AUTOSAR_BSW_Module_Description.pdf

3.2 Related standards and norms

- [9] OSEK/VDX NM Specification (ISO 17356-5), Version 2.5.3
<http://www.osek-vdx.org/>

4 Constraints and assumptions

4.1 Limitations

1. The AUTOSAR NM Interface can only be applied to communication systems that support broadcast communication and Bus-sleep mode.
2. There will be only one instance of the NM Interface layer for all NM-Clusters, this instance manages all channels where AUTOSAR NM is run.
3. The NM Interface shall only include the common modes, definitions and return values of different Bus Specific Network management layers.

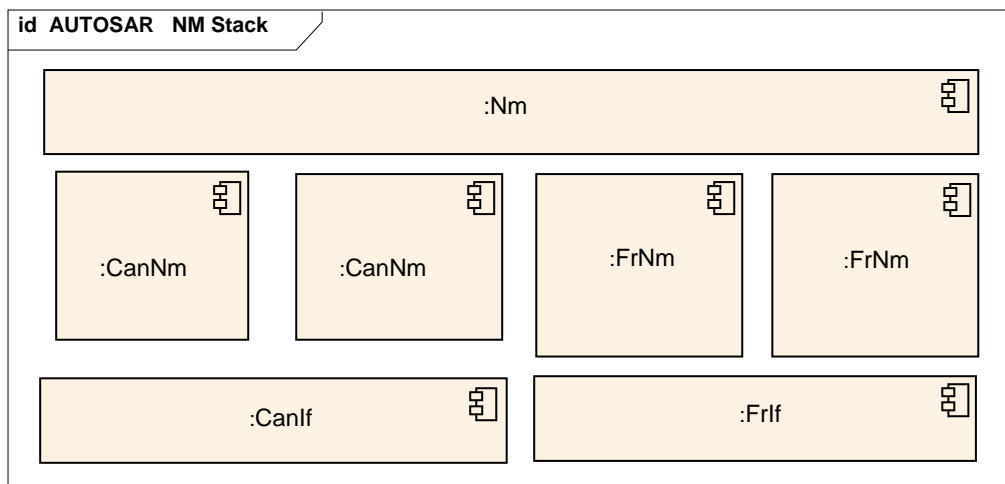

Figure 4.1

4.2 Specific limitations of the coordinator functionality for AUTOSAR release 3

A main target of the coordinator part of the specification is to avoid adding new interfaces to the other NM modules. Therefrom result some restrictions:

- No support of a back-up coordinator ECU (fault tolerance)
- No support to synchronize additional coordinators on the busses which handle sub-busses

For the inclusion of OSEK NM, the following restriction applies:

- No support to run AUTOSAR NM and direct OSEK NM on the same bus

The concepts for support these extended use cases exist, but they cannot be implemented without additional interfaces. They are planned to be included in AUTOSAR release 4.

In addition, for the inclusion of direct OSEK NM, the following assumption is made:

- Nm049 The OSEK NM implementation shall support a feature extension, which is already present within some OSEK NM implementations for gateways. This feature extension observes the sleep indication of other ECU's in one ring (called "RemoteSleepIndication")

4.3 Applicability to car domains

The AUTOSAR NM Interface is generic and provides flexible configuration; it is independent of the underlying communication system and can be applied to any car domain under limitations provided above.

5 Dependencies to other modules

5.1 Interfaces to modules

5.1.1 ComM, CanNm, FrNm, LinNm

The Generic Network Management Interface Module provides services to the Communication Manager (ComM) and uses services of the respective bus specific Network management adaptation layers (CanNm, FrNm and LinNm¹) as shown in Figure 5.1.

¹ LinNm is not within the scope of the current AUTOSAR NM Release

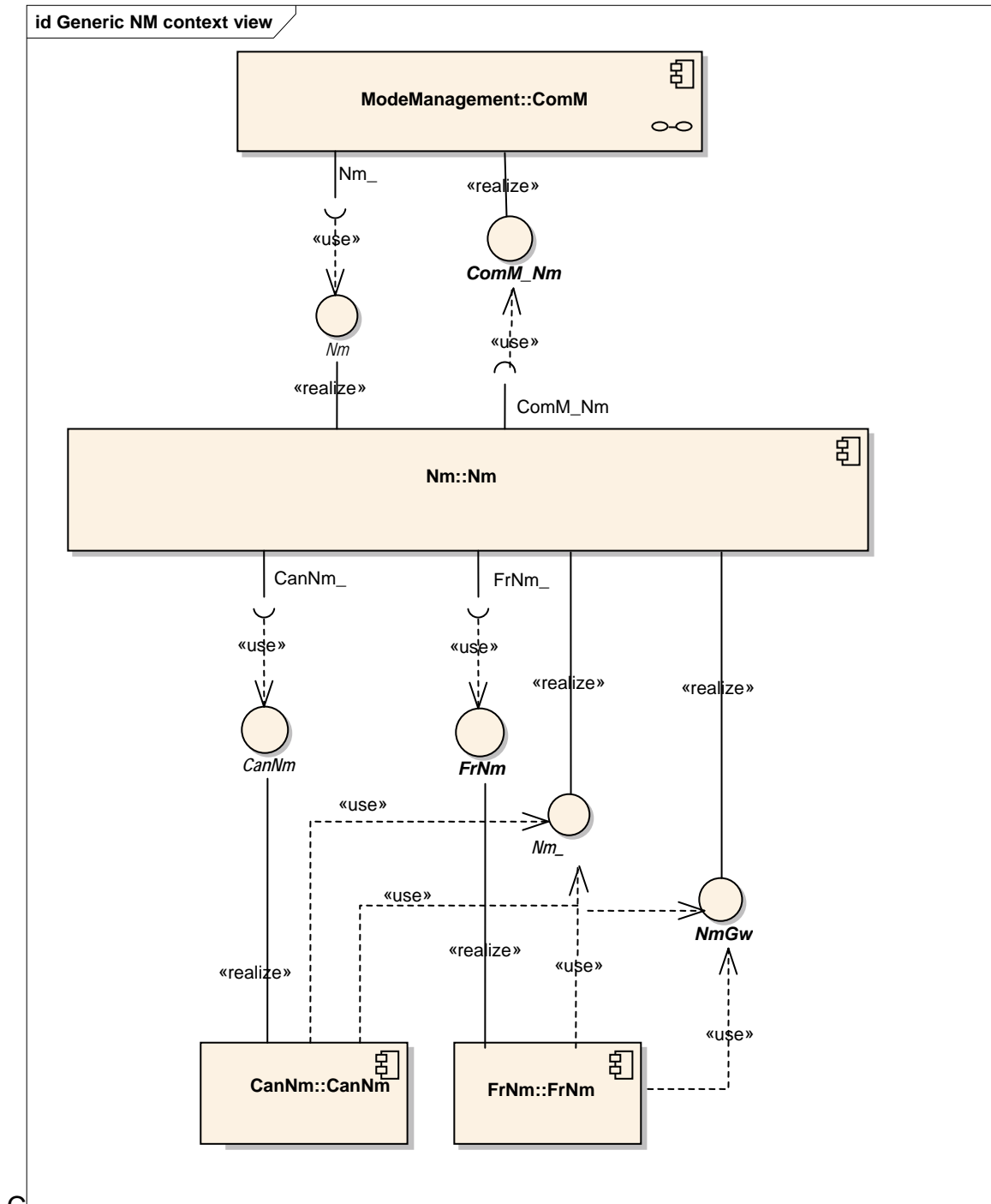

Figure 5.1

5.1.2 DET, DEM

For production errors, please refer to [Nm025](#)

For production errors, please refer to [Nm026](#).

5.1.3 BSW Scheduler

In case of the NM coordinator functionality, depending on the implementation the NM Interface module may also need a main function, and thus interface to the BSW Scheduler.

5.2 File structure

5.2.1 Code file structure

The Nm module shall provide the following C-files:

- Nm.c (for implementation of provided functionality)

However, no C-files will be necessary if this module is implemented as a MACRO

5.2.2 Header file structure

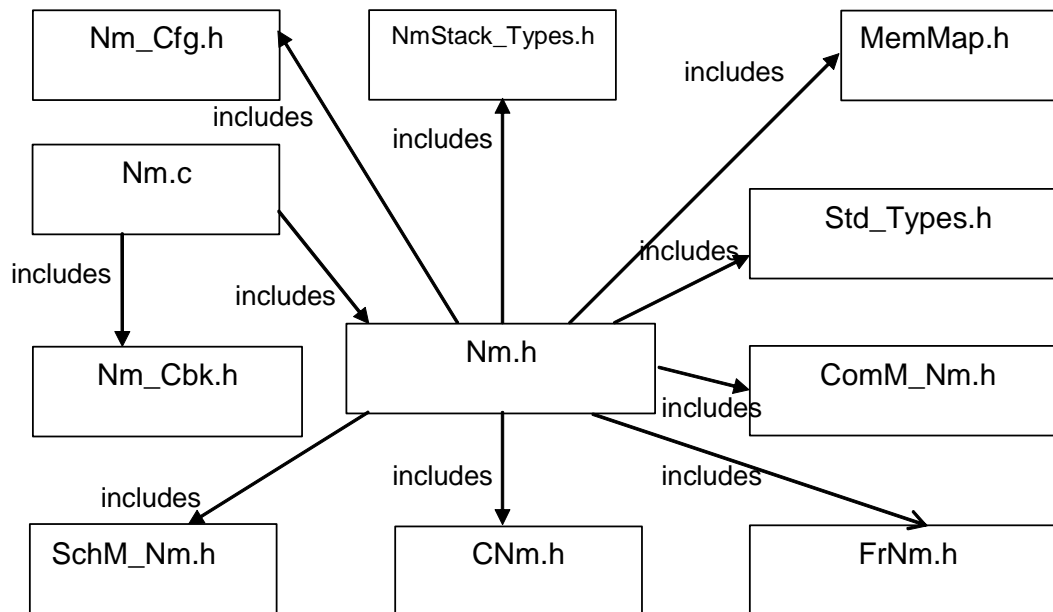

Figure 5.2

The Nm Interface module shall provide the following header files:

- Nm.h (for declaration of provided interface functions)
- Nm_Cbk.h (for declaration of provided call-back functions)
- Nm_Cfg.h (for pre-compile time configurable parameters)
- NmStack_Types.h

The following header files will be included within the Nm Interface module:

- `Std_Types.h` (for AUTOSAR standard types - Note: `Platform_Types.h` (for platform specific types) and `Compiler.h` (for compiler specific language extensions) are indirectly included via AUTOSAR standard types)
- `MemMap.h` (for memory abstraction)
- `SchM_Nm.h` (for interfaces with the BSW Scheduler)
- `CanNm.h` (for interface of CAN Generic specific NM; included only if CAN Generic NM is available)
- `FrNm.h` (for interface of FlexRay specific NM; included only if FlexRay NM is available)
- `ComM_Nm.h` (for Communication Manager callback functions)

6 Requirements traceability

Document: AUTOSAR Requirements on Basic Software Modules [2]

Requirement	Satisfied by
[BSW00344] Reference to link-time configuration	NA (no link time parameters)
[BSW00404] Reference to post build time configuration	NA (no post built parameter)
[BSW00405] Reference to multiple configuration sets	Nm030
[BSW00345] Pre-compile-time configuration	Nm.h and Nm_Cfg.h defined
[BSW159] Tool-based configuration	Implementation provider requirement
[BSW167] Static configuration checking	NA
[BSW170] Data for reconfiguration of AUTOSAR SW-Components	NA
[BSW171] Configurability of optional functionality	Several switches, e.g.: NmUserDataEnabled, NmNodeDetectionEnabled, Nm055
[BSW00380] Separate C-Files for configuration parameters	NA (no link time or post built parameters)
[BSW00419] Separate C-Files for pre-compile time configuration parameters	NA (no link time or post built parameters)
[BSW00381] Separate configuration header file for pre-compile time parameters	NA (no link time or post built parameters)
[BSW00412] Separate H-File for configuration parameters	NA (no link time or post built parameters)
[BSW00383] List dependencies of configuration files	Described in chapter 5
[BSW00384] List dependencies to other modules	Described in chapter 5
[BSW00387] Specify the configuration class of callback function	Nm091
[BSW00388] Introduce containers	Chapter 10.2
[BSW00389] Containers shall have names	NA
[BSW00390] Parameter content shall be unique within the module	ok
[BSW00391] Parameter shall have unique names	ok
[BSW00392] Parameters shall have a type	ok
[BSW00393] Parameters shall have a range	ok
[BSW00394] Specify the scope of the parameters	ok
[BSW00395] List the required parameters (per parameter)	ok
[BSW00396] Configuration classes	specified (pre-compile only)
[BSW00397] Pre-compile-time parameters	ok
[BSW00398] Link-time parameters	NA
[BSW00399] Loadable Post-build time parameters	NA
[BSW00400] Selectable Post-build time parameters	NA
[BSW00402] Published information	Included (Nm008)
[BSW00375] Notification of wake-up reason	NA (no wake-up interrupt handled)
[BSW101] Initialization interface	Nm030
[BSW00416] Sequence of Initialization	Nm121
[BSW00406] Check module initialization	Errors defined in interfaces
[BSW168] Diagnostic Interface of SW components	NA
[BSW00407] Function to read out published parameters	Function included
[BSW00423] Usage of SW-C template to describe BSW modules with AUTOSAR Interfaces	ok
[BSW00424] BSW main processing function task allocation	ok
[BSW00425] Trigger conditions for schedulable objects	Main function is periodic
[BSW00426] Exclusive areas in BSW modules	NA (no exclusive areas)
[BSW00427] ISR description for BSW modules	NA (no ISRs)

[BSW00428] Execution order dependencies of main processing functions	Nm014
[BSW00429] Restricted BSW OS functionality access	ok
[BSW00431] The BSW Scheduler module implements task bodies	ok
[BSW00432] Modules should have separate main processing functions for read/receive and write/transmit data path	NA
[BSW00433] Calling of main processing functions	ok
[BSW00434] The Schedule Module shall provide an API for exclusive areas	NA
[BSW00336] Shutdown interface	NA
[BSW00337] Classification of errors	Ok: checking for NetworkHandle validity included in the interfaces, yields development errors
[BSW00338] Detection and Reporting of development errors	Nm022 , Nm023 , Nm025
[BSW00369] Do not return development error codes via API	ok
[BSW00339] Reporting of production relevant error status	Nm026
[BSW00417] Reporting of Error Events by Non-Basic Software	NA
[BSW00323] API parameter checking	Checking for NetworkHandle validity included in the interfaces
[BSW004] Version check	All necessary data available. Performance of preprocessor check is an implementation provider requirement
[BSW00409] Header files for production code error IDs	Implementation issue
[BSW00385] List possible error notifications	Chapter 8.2.1
[BSW00386] Configuration for detecting an error	NA
[BSW161] Microcontroller abstraction	Ok, NM Interface is HW independent
[BSW162] ECU layout abstraction	Ok, NM Interface is HW independent
[BSW005] No hard coded horizontal interfaces within MCAL	Ok
[BSW00415] User dependent include files	NA
[BSW164] Implementation of interrupt service routines	NA
[BSW00325] Runtime of interrupt service routines	NA
[BSW00326] Transition from ISRs to OS tasks	NA
[BSW00342] Usage of source code and object code	NA, NM Interface is pre-compile only
[BSW00343] Specification and configuration of time	Ok
[BSW160] Human-readable configuration data	Ok
[BSW007] HIS MISRA C	Ok in specification, rest is an implementation provider requirement
[BSW00300] Module naming convention	Ok (Nm)
[BSW00413] Accessing instances of BSW modules	NA (no instantiation of NM Interface)
[BSW00347] Naming separation of different instances of BSW drivers	NA
[BSW00305] Self-defined data types naming convention	Ok
[BSW00307] Global variables naming convention	Ok
[BSW00310] API naming convention	Ok
[BSW00373] Main processing function naming convention	Nm020
[BSW00327] Error values naming convention	Ok
[BSW00335] Status values naming convention	Ok
[BSW00350] Development error detection keyword	Chapter 10.2
[BSW00408] Configuration parameter naming convention	Ok
[BSW00410] Compiler switches shall have defined values	Chapter 10.2
[BSW00411] Get version info keyword	Chapter 10.2

[BSW00346] Basic set of module files	Chapter 5.2.2
[BSW158] Separation of configuration from implementation	Ok
[BSW00314] Separation of interrupt frames and service routines	NA
[BSW00370] Separation of callback interface from API	Chapter 5.2.2
[BSW00348] Standard type header	Chapter 5.2.2
[BSW00353] Platform specific type header	NA
[BSW00361] Compiler specific language extension header	NA
[BSW00301] Limit imported information	Nm117
[BSW00302] Limit exported information	Ok
[BSW00328] Avoid duplication of code	Ok
[BSW00312] Shared code shall be reentrant	Ok
[BSW006] Platform independency	Ok
[BSW00357] Standard API return type	Ok
[BSW00377] Module specific API return types	Ok
[BSW00304] AUTOSAR integer data types	Ok
[BSW00355] Do not redefine AUTOSAR integer data types	Ok
[BSW00378] AUTOSAR boolean type	Ok
[BSW00306] Avoid direct use of compiler and platform specific keywords	Ok
[BSW00308] Definition of global data	NA
[BSW00309] Global data with read-only constraint	Ok
[BSW00371] Do not pass function pointers via API	Ok
[BSW00358] Return type of init() functions	Ok
[BSW00414] Parameter of init function	Ok
[BSW00376] Return type and parameters of main processing functions	Ok
[BSW00359] Return type of callback functions	Ok
[BSW00360] Parameters of callback functions	Ok
[BSW00329] Avoidance of generic interfaces	Ok
[BSW00330] Usage of macros / inline functions instead of functions	The NM Interface module (except the coordinator part) may be delivered totally as macros (Nm091)
[BSW00331] Separation of error and status values	Ok
[BSW009] Module User Documentation	Implementation provider requirement
[BSW00401] Documentation of multiple instances of configuration parameters	NA
[BSW172] Compatibility and documentation of scheduling strategy	Not applicable (no internal scheduling policy)
[BSW010] Memory resource documentation	Implementation provider requirement
[BSW00333] Documentation of callback function context	Nm028
[BSW00374] Module vendor identification	Nm008
[BSW00379] Module identification	Nm008
[BSW003] Version identification	Nm008 , Nm044
[BSW00318] Format of module version numbers	Nm008
[BSW00321] Enumeration of module version numbers	Implementation provider requirement
[BSW00341] Microcontroller compatibility documentation	NA
[BSW00334] Provision of XML file	Ok

Document: AUTOSAR Requirements on Basic Software, Module NM [3]

Requirement	Satisfied by
[BSW150] Configuration of functionality	Ok, e.g. Nm055
[BSW151] Integration into running NM cluster	Nm031

[BSW043] Bus Traffic without NM Initialization	NA
[BSW044] Applicability to different types of communication systems	Currently limited to Can and Fr, but not by NM Interface
[BSW045] NM-cluster Independent Shutdown Coordination	via coordinator functionality (chapter 7) (Nm003 , Nm007 , Nm033)
[BSW046] Trigger of startup of all Nodes at any Point in Time	Ok: init function can be called any time, bus specific strategies not part of NM Interface
[BSW047] Bus Keep Awake Services	Nm032 , Nm034
[BSW048] Bus Sleep Mode	Nm046
[BSW050] NM State Information	Nm043
[BSW051] NM State Change Indication	Ok, see ComM interfaces
[BSW052] Notification that all other ECUs are ready to sleep	NA (coordinator functionality merged with interface functionality, therefore handled internally)
[BSW02509] Notification that at least one other node is not ready to sleep anymore	Nm_NetworkStartIndication
[BSW02503] Sending user data	Nm035
[BSW02504] Receiving user data	Nm036
[BSW153] Detection of present nodes	Nm038
[BSW02508] Unambiguous node identification per bus	Nm040
[BSW02505] Sending node identifier	Nm039
[BSW02506] Receiving node identifier	Nm037
[BSW02511] Configurable Role in Cluster Shutdown	NA (bus specific part)
[BSW053] Deterministic Behavior in Case of Bus Unavailability	NA (bus specific part)
[BSW137] Communication system error handling	NA (bus specific part)
[BSW136] Coordination of coupled networks	Nm001 , Nm002 , Nm003 , Nm004 , Nm042 , Nm112 , Nm114 , Nm115
[BSW140] Compliance with OSEK NM on a gateway	Nm002 , Nm003 , Nm004 , Nm049 , Nm053 , Nm056 , Nm115 , Nm116
[BSW054] Deterministic Time for Bus Sleep	NA (bus specific part)
[BSW142] Limitation of NM bus load	NA (bus specific part)
[BSW143] Predictable NM bus load	NA (bus specific part)
[BSW144] ECU cluster size	NA (bus specific part)
[BSW145] Robustness against NM message losses	NA (bus specific part)
[BSW146] Robustness against NM message jitter	NA (bus specific part)
[BSW147] Processor independent algorithm	Nm095
[BSW149] Configurable Timing	Nm097
[BSW154] Bus independency of API	Chapter 8.3 (no bus specific parameter), Nm095 , Nm006 , Nm012
[BSW148] Separation of Communication system dependent parts	Separated into CanNm and FrNm
[BSW139] Compliance with OSEK NM on one cluster	Nm053 , Nm056 (direct OSEK NM only)
[BSW02510] Immediate Transmission Confirmation	
[BSW02512] CommunicationControl (28 hex) service support	Nm028 , Nm034

7 Functional specification

The NM Interface functionality consists of two parts:

- The base functionality necessary to run, together with the bus specific NM modules, AUTOSAR NM on an ECU
- The NM coordinator functionality used by gateway ECUs to synchronously shut down more than one bus

7.1 Base functionality

The AUTOSAR NM Interface module shall act as a bus-independent adaptation layer between the bus-specific Network Management modules (CanNm, and FrNm) and the AUTOSAR basic software module Communication Manager.

Nm095 No specific knowledge of the type of the underlying busses shall be present in the NM Interface module.

Because of this requirement, the algorithm handled by the AUTOSAR NM Interface shall be bus independent.

Nm006 The NM Interface module shall convert generic function calls to bus specific functions of the bus specific NM layer.

Nm012 The NM Interface module shall convert callback functions of the bus specific NM layer to generic callbacks to the Communication Manager.

Nm091 It shall be allowed to implement the base functionality completely or partly using macros.

7.2 NM coordinator functionality

A NM coordinator is an ECU, which is connected to at least two busses, and where the requirement exists that shutdown of NM of at least two of these busses (also referred to as 'coordinated busses') has to be performed synchronously. These busses are referred to as 'coordinated busses', the algorithm to shutdown synchronously is referred to as 'coordinator algorithm'.

Nm001 The coordinator algorithm shall be able to handle a topology where several coordinated busses are connected to a NM coordinator.

Nm051 On each of the coordinated busses it shall be possible to run AUTOSAR NM.

Nm055 It shall be configurable if the coordinator algorithm to support AUTOSAR NM is present.

Nm053 On each of the coordinated busses it shall be possible to run direct OSEK NM.

Nm056 It shall be configurable if the coordinator algorithm to support OSEK NM is present in addition to the coordinator algorithm for AUTOSAR NM ([Nm055](#)).

Nm002 As long as AUTOSAR NM or direct OSEK NM on a NM coordinator node is not ready to sleep on at least one of the coordinated busses (this means the node

itself is not ready to sleep on all coordinated busses) the NM coordinator shall act on all coordinated busses as if it is not ready to sleep.

Because of this requirement, the normal AUTOSAR NM or direct OSEK NM algorithm is performed. As in both algorithms, a bus is kept awake if at least one node needs the bus, the NM coordinator will automatically keep all coordinated busses awake.

Nm003 If a NM coordinator is ready to sleep on all coordinated busses, but at least one of the coordinated busses is kept awake by a node that is not the coordinator node, the NM coordinator shall act on all coordinated busses as if it is not ready to sleep.

This means that in this case the coordinator node shall still act as if it is not ready to sleep on the coordinated busses.

The two requirements above can be summarized as follows: as long as at least one node keeps any of the coordinated busses awake, the NM coordinator shall keep all coordinated busses awake.

The algorithm to detect on AUTOSAR CAN NM if some other node on a bus is not ready to sleep depends on a specific property of the AUTOSAR NM algorithm. The timeout for nodes that have sent a NM message is defined such that a second node will send in-between before the first node will send another NM message.

If the NM coordinator keeps the bus awake, there are two possibilities:

- At least one other node on the same bus needs the bus. Because of the algorithm, one of these nodes will send in-between the NM messages of the NM coordinator
- No other node needs the bus. Because of the algorithm, the NM coordinator will be the only node to send NM messages on the bus

To detect the situation that no other node needs the bus – if the coordinator itself does not need the bus any more -, the RemoteSleepIndication functionality of the underlying layers is used.

For details of the algorithm, please refer to the Can NM SWS [4].

For AUTOSAR FlexRay NM, if no NM-messages with an indication to keep the bus awake are received in the Normal Operation State for a configurable amount of time AUTOSAR FlexRay NM notifies the NM Interface that all other nodes in the cluster are ready to sleep.

OSEK NM uses a token bus like algorithm: a specific message is passed from node to node. In this message, the sending node informs the other nodes if it is ready to sleep. Thus, if all nodes except the NM coordinator inform that they are ready to sleep (via RemoteSleepIndication, see [Nm049](#)), the NM coordinator can assume that this bus is ready to go to sleep. OSEK NM offers as extension a service to collect the information if all other nodes on a specific bus are ready to sleep.

If on all coordinated busses the only sending node is the NM coordinator, and the NM coordinator itself needs none of the coordinated busses any more, the NM coordinator can put all coordinated busses to sleep. To do this, it needs to send final

NM messages on the busses. These final messages have to be timed according to the individual timing of the coordinated busses such that the busses are put to sleep synchronously.

Nm004 If the NM coordinator detects that for all coordinated busses all of the following conditions apply:

1. on all coordinated busses AUTOSAR NM is run, for a configurable number of NM message transmissions² of the NM coordinator (see [Nm097](#)), there has been no AUTOSAR NM message except the AUTOSAR NM messages sent by the NM coordinator
2. on all coordinated busses OSEK NM is run, for a configurable number of NM message transmissions of the NM coordinator (see [Nm099](#)), all other nodes have only sent NM messages which state that the node is ready to go to sleep (using RemoteSleepIndication, see [Nm049](#))
3. the NM coordinator is ready to sleep

the NM coordinator shall request NM message transmission on all coordinated busses such that the a synchronous shutdown is achieved. (For limits, see comment further below.)

Nm115 For the algorithm described in [Nm004](#), the coordinator shall ignore coordinated busses which have not successfully performed at all, or after the last successful Nm_NetworkRelease (or the equivalent OSEK NM functionality), a successful Nm_NetworkRequest (or the equivalent OSEK NM functionality).

Please note that there are limits to how much synchrony can be achieved when shutting down busses. Whereas CAN NM can in its timing be influenced by requesting NM message transmissions, FlexRay has a fixed time value for rounds, and OSEK NM has indirectly a fixed time value for rounds via the number of nodes. Therefore, it is not possible to meet an arbitrary point in time, and synchrony is only possible within certain tolerances. This is also partly determined by configuration values (e.g. the time a FlexRay round needs).³

Synchronous wake up is not required and not included in the concept, because the COM Manager will wake up all coordinated busses when one of the coordinated busses informs the COM Manager about a wakeup event. However, there are races possible if the coordinated shutdown is performed and a bus comes up again before all busses have entered sleep mode.

Nm116: If NmIf has started to shut down the coordinated busses, AND not all coordinated busses have signaled bus sleep state, AND on at least on one of the coordinated busses NM is restarted, THEN the NM Interface shall call the callback

² The configurable number of rounds delays the detection that all busses are ready to go to sleep. This is useful if there is a high probability that within a certain amount of time one of the busses is needed again. In addition, if a NM message has been lost, this number must be set such that it is certain that the bus is not needed any more.

³ A more precise algorithm is possible if information is available about when FlexRay rounds begin. As information about some state changes is communicated on FlexRay round boundaries between the Communication Manager and FlexRay NM, this information can be taken into account.

function `ComM_Nm_RestartIndication` with the `nmNetworkHandle` of the waking channel as parameter AND the appropriate function in OSEK NM for all of the coordinated busses which run OSEK NM.

7.3 Error classification

This specification will not contain any error classification.

7.4 Error detection

Nm022 The detection of development errors is configurable (*ON / OFF*) at pre-compile time.

The switch `NmDevErrorDetect` shall activate or deactivate the detection of all development errors.

Nm023 If the `NmDevErrorDetect` switch is enabled, API parameter checking shall be enabled.

7.5 Error notification

Nm025 Detected development errors shall be reported to the `Det_ReportError` service of the Development Error Tracer (DET) if the pre-processor switch `NmDevErrorDetect` is set, except if the respective service is implemented as macro ([Nm091](#)).

Nm026 Production errors shall be reported to Diagnostic Event Manager (DEM) if and only if they originate from the coordinator functionality. Otherwise, it is assumed that the underlying module (FrNm etc.) has already reported to DEM.

8 API specification

8.1 Imported types

In this chapter all types included from the following files are listed:

Nm117:

Header file	Imported Type
CanNm_Types.h	CanNm_ConfigType
FrNm_Types.h	NetworkHandleType FrNm_ConfigType
Std_Types.h	Std_VersionInfoType
ComStack_Types.h	NetworkHandleType

8.2 Type definitions

8.2.1 Nm_ReturnType

Name:	Nm_ReturnType	
Type:	Enumeration	
Range:	NM_E_OK	Function call has been successfully accomplished and returned.
	NM_E_NOT_OK	Function call has been unsuccessfully accomplished and returned because of an internal execution error.
	NM_E_NOT_EXECUTED	Function call is not executed.
Description:	Return type for NM functions. Derived from Std_ReturnType.	

8.2.2 Nm_ModeType

Name:	Nm_ModeType	
Type:	Enumeration	
Range:	NM_MODE_BUS_SLEEP	Bus-Sleep Mode
	NM_MODE_PREPARE_BUS_SLEEP	Prepare-Bus Sleep Mode
	NM_MODE_SYNCHRONIZE	Synchronize Mode
	NM_MODE_NETWORK	Network Mode
Description:	Operational modes of the network management.	

8.2.3 Nm_StateType

Name:	Nm_StateType	
Type:	Enumeration	
Range:	NM_STATE_UNINIT	Uninitialized State (0)
	NM_STATE_BUS_SLEEP	Bus-Sleep State (1)
	NM_STATE_PREPARE_BUS_SLEEP	Prepare-Bus State (2)
	NM_STATE_READY_SLEEP	Ready Sleep State (3)
	NM_STATE_NORMAL_OPERATION	Normal Operation State (4)
	NM_STATE_REPEAT_MESSAGE	Repeat Message State (5)

	NM_STATE_SYNCHRONIZE	Synchronize State (6)
Description:	States of the network management state machine.	

8.2.4 Nm_BusNmType

Name:	Nm_BusNmType	
Type:	Enumeration	
Range:	NM_BUSNM_CANNM	CAN NM type
	NM_BUSNM_FRNM	FR NM type
	NM_BUSNM_LINNM	LIN NM type
	NM_BUSNM_UNDEF	NM type undefined; it shall be defined as FFh
Description:	BusNm Type	

8.2.5 Nm_BusNm_ConfigType

Name:	Nm_BusNm_ConfigType		
Type:	Structure		
Element:	const CanNm_ConfigType*	CanNmConfigPtr	Only available if NM_BUSNM_CANNM_ENABLED is set to ON
	const FrNm_ConfigType *	FrNmConfigPtr	Only available if NM_BUSNM_FRNM_ENABLED is set to ON
Description:	Data structure shall be pre-compile time configurable.		

8.3 Function definitions

8.3.1 Services provided by NM Interface

8.3.1.1 Nm_Init

Nm030:

Service name:	Nm_Init	
Syntax:	void Nm_Init(Nm_ConfigType * const nmConfigPtr)	
Service ID[hex]:	0x00	
Sync/Async:	Synchronous	
Reentrancy:	Non Reentrant	
Parameters (in):	nmConfigPtr	Pointer to the selected configuration set
Parameters (inout):	None	
Parameters (out):	None	
Return value:	None	
Description:	Initializes the NM Interface.	

Caveats of Nm_Init: This service function has to be called after the initialization of the respective bus interface.

Configuration of Nm_Init: Mandatory

8.3.1.2 Nm_PassiveStartUp

Nm031:

Service name:	Nm_PassiveStartUp	
Syntax:	Nm_ReturnType Nm_PassiveStartUp(const NetworkHandleType NetworkHandle)	
Service ID[hex]:	0x01	
Sync/Async:	Synchronous	
Reentrancy:	Non-reentrant for the same NetworkHandle, reentrant otherwise	
Parameters (in):	NetworkHandle	Identification of the NM-channel
Parameters (inout):	None	
Parameters (out):	None	
Return value:	Nm_ReturnType	NM_E_OK: No error NM_E_NOT_OK: Passive start of network management has failed NetworkHandle does not exist (development only) module not yet initialized (development only) NM_E_NOT_EXECUTED: Passive start of network management has not executed
Description:	This function calls the <BusNm>_PassiveStartUp function (e.g. CanNm_PassiveStartUp function is called if channel is configured as CAN).	

Caveats of Nm_PassiveStartUp: CanNm and FrNm are initialized correctly.

Configuration of Nm_PassiveStartUp: Mandatory

8.3.1.3 Nm_NetworkRequest

Nm032:

Service name:	Nm_NetworkRequest	
Syntax:	Nm_ReturnType Nm_NetworkRequest(const NetworkHandleType NetworkHandle)	
Service ID[hex]:	0x02	
Sync/Async:	Synchronous	
Reentrancy:	Non-reentrant for the same NetworkHandle, reentrant otherwise	
Parameters (in):	NetworkHandle	Identification of the NM-channel
Parameters (inout):	None	
Parameters (out):	None	
Return value:	Nm_ReturnType	NM_E_OK: No error NM_E_NOT_OK: Requesting of bus communication has failed NetworkHandle does not exist (development only)

		module not yet initialized (development only) NM_E_NOT_EXECUTED: Function to request bus communication not executed
Description:	This function calls the <BusNm>_NetworkRequest (e.g. CanNm_NetworkRequest function is called if channel is configured as CAN).	

Caveats of Nm_NetworkRequest: The <BusNm> and the Nm itself are initialized correctly.

Configuration of Nm_NetworkRequest: Optional (Only available if NmPassiveModeEnabled is set to OFF)

8.3.1.4 Nm_NetworkRelease

Nm046:

Service name:	Nm_NetworkRelease	
Syntax:	Nm_ReturnType Nm_NetworkRelease(const NetworkHandleType NetworkHandle)	
Service ID[hex]:	0x03	
Sync/Async:	Synchronous	
Reentrancy:	Non-reentrant for the same NetworkHandle, reentrant otherwise	
Parameters (in):	NetworkHandle	Identification of the NM-channel
Parameters (inout):	None	
Parameters (out):	None	
Return value:	Nm_ReturnType	NM_E_OK: No error NM_E_NOT_OK: Releasing of bus communication has failed NetworkHandle does not exist (development only) module not yet initialized (development only) NM_E_NOT_EXECUTED: Function to release bus communication not executed
Description:	This function calls the <BusNm>_NetworkRelease bus specific function (e.g. CanNm_NetworkRelease function is called if channel is configured as CAN).	

Caveats of Nm_NetworkRelease: The <BusNm> and the Nm itself are initialized correctly.

Configuration of Nm_NetworkRelease: Optional (Only available if NmPassiveModeEnabled is set to OFF)

8.3.1.5 Nm_DisableCommunication

Nm033:

Service name:	Nm_DisableCommunication	
Syntax:	Nm_ReturnType Nm_DisableCommunication(const NetworkHandleType NetworkHandle)	
Service ID[hex]:	0x04	

Sync/Async:	Synchronous	
Reentrancy:	Non-reentrant for the same NetworkHandle, reentrant otherwise	
Parameters (in):	NetworkHandle	Identification of the NM-channel
Parameters (inout):	None	
Parameters (out):	None	
Return value:	Nm_ReturnType	NM_E_OK: No error NM_E_NOT_OK: Disabling of NM PDU transmission ability has failed. NetworkHandle does not exist (development only) module not yet initialized (development only) NM_E_NOT_EXECUTED: Disabling of NM PDU transmission ability is not executed.
Description:	This function calls the CanNm_NetworkRelease bus specific function, to disable the NM PDU transmission ability due to a ISO14229 Communication Control (28hex) service	

Caveats of Nm_DisableCommunication: CanNm are initialized correctly

Configuration of Nm_DisableCommunication: Optional (Only available if NmComControlEnabled is defined)

8.3.1.6 Nm_EnableCommunication

Nm034:

Service name:	Nm_EnableCommunication	
Syntax:	Nm_ReturnType Nm_EnableCommunication(const NetworkHandleType NetworkHandle)	
Service ID[hex]:	0x05	
Sync/Async:	Synchronous	
Reentrancy:	Non-reentrant for the same NetworkHandle, reentrant otherwise	
Parameters (in):	NetworkHandle	Identification of the NM-channel
Parameters (inout):	None	
Parameters (out):	None	
Return value:	Nm_ReturnType	NM_E_OK: No error NM_E_NOT_OK: Enabling of NM PDU transmission ability has failed. NetworkHandle does not exist (development only) module not yet initialized (development only) NM_E_NOT_EXECUTED: Enabling of NM PDU transmission ability is not executed.
Description:	This function calls the CanNm_NetworkRequest bus specific function, to enable the NM PDU transmission ability due to a ISO14229 Communication Control (28hex) service	

Caveats of Nm_EnableCommunication: CanNm is initialized correctly.

Configuration of Nm_EnableCommunication: Optional (Only available if NmComControlEnabled is defined)

8.3.1.7 Nm_SetUserData

Nm035:

Service name:	Nm_SetUserData	
Syntax:	<pre>Nm_ReturnType Nm_SetUserData(const NetworkHandleType NetworkHandle, const uint8 * const nmUserDataPtr)</pre>	
Service ID[hex]:	0x06	
Sync/Async:	Synchronous	
Reentrancy:	Non-reentrant for the same NetworkHandle, reentrant otherwise	
Parameters (in):	NetworkHandle	Identification of the NM-channel
	nmUserDataPtr	User data for the next transmitted NM message
Parameters (inout):	None	
Parameters (out):	None	
Return value:	Nm_ReturnType	NM_E_OK: No error NM_E_NOT_OK: Setting of user data has failed NetworkHandle does not exist (development only) module not yet initialized (development only)
Description:	Set user data for NM messages transmitted next on the bus. For that purpose <BusNm>_SetUserData shall be called (e.g. CanNm_SetUserData function is called if channel is configured as CAN).	

Caveats of Nm_SetUserData: The <BusNm> and the Nm itself are initialized correctly.

Configuration of Nm_SetUserData: Optional (Only available if NmUserDataEnabled and NmPassiveModeEnabled is defined)

8.3.1.8 Nm_GetUserData

Nm036:

Service name:	Nm_GetUserData	
Syntax:	<pre>Nm_ReturnType Nm_GetUserData(const NetworkHandleType NetworkHandle, uint8 * const nmUserDataPtr, uint8 * const nmNodeIdPtr)</pre>	
Service ID[hex]:	0x07	
Sync/Async:	Synchronous	
Reentrancy:	Non-reentrant for the same NetworkHandle, reentrant otherwise	
Parameters (in):	NetworkHandle	Identification of the NM-channel
Parameters (inout):	None	
Parameters (out):	nmUserDataPtr	Pointer where user data out of the last successfully received NM message shall be copied to
	nmNodeIdPtr	Pointer where node identifier out of the last successfully received NM message shall be copied to
Return value:	Nm_ReturnType	NM_E_OK: No error NM_E_NOT_OK: Getting of user data has failed

		NetworkHandle does not exist (development only) module not yet initialized (development only)
Description:	Get user data out of the last successfully received NM message. For that purpose <BusNm>_GetUserData shall be called (e.g. CanNm_GetUserData function is called if channel is configured as CAN).	

Caveats of Nm_GetUserData: The <BusNm> and the Nm itself are initialized correctly.

Configuration of Nm_GetUserData: Optional (Only available if NmUserDataEnabled is set to ON)

8.3.1.9 Nm_GetPduData

Nm037:

Service name:	Nm_GetPduData	
Syntax:	Nm_ReturnType Nm_GetPduData(const NetworkHandleType NetworkHandle, uint8 * const nmPduData)	
Service ID[hex]:	0x08	
Sync/Async:	Synchronous	
Reentrancy:	Non-reentrant for the same NetworkHandle, reentrant otherwise	
Parameters (in):	NetworkHandle	Identification of the NM-channel
Parameters (inout):	None	
Parameters (out):	nmPduData	Pointer where NM PDU shall be copied to.
Return value:	Nm_ReturnType	NM_E_OK: No error NM_E_NOT_OK: Getting of NM PDU data has failed NetworkHandle does not exist (development only) module not yet initialized (development only)
Description:	Get the whole PDU data out of the most recently received NM message. For that purpose CanNm_GetPduData shall be called.	

Caveats of Nm_GetPduData: The <BusNm> and <Nm> are initialized correctly

Configuration of Nm_GetPduData: Optional (Only available if NmNodeIdEnabled or NmNodeDetectionEnabled or NmUserDataEnabled is set to

8.3.1.10 Nm_RepeatMessageRequest

Nm038:

Service name:	Nm_RepeatMessageRequest	
Syntax:	Nm_ReturnType Nm_RepeatMessageRequest(const NetworkHandleType NetworkHandle)	
Service ID[hex]:	0x09	
Sync/Async:	Synchronous	
Reentrancy:	Non-reentrant for the same NetworkHandle, reentrant otherwise	
Parameters (in):	NetworkHandle	Identification of the NM-channel

Parameters (inout):	None	
Parameters (out):	None	
Return value:	Nm_ReturnType	NM_E_OK: No error NM_E_NOT_OK: Setting of Repeat Message Request Bit has failed NetworkHandle does not exist (development only) module not yet initialized (development only) NM_E_NOT_EXECUTED: Repeat Message Request is currently not executed.
Description:	Set Repeat Message Request Bit for NM messages transmitted next on the bus. For that purpose <BusNm>_RepeatMessageRequest shall be called (e.g. CanNm_RepeatMessageRequest function is called if channel is configured as CAN)	

Caveats of Nm_RepeatMessageRequest: FrNm and CanNm itself are initialized correctly.

Configuration of Nm_RepeatMessageRequest: Optional (Only available if NmNodeDetectionEnabled is defined)

8.3.1.11 Nm_GetNodeIdentifier

Nm039:

Service name:	Nm_GetNodeIdentifier	
Syntax:	Nm_ReturnType Nm_GetNodeIdentifier(const NetworkHandleType NetworkHandle, uint8 * const nmNodeIdPtr)	
Service ID[hex]:	0x0a	
Sync/Async:	Synchronous	
Reentrancy:	Non-reentrant for the same NetworkHandle, reentrant otherwise	
Parameters (in):	NetworkHandle Identification of the NM-channel	
Parameters (inout):	None	
Parameters (out):	nmNodeIdPtr	Pointer where node identifier out of the last successfully received NM-message shall be copied to
Return value:	Nm_ReturnType	NM_E_OK: No error NM_E_NOT_OK: Getting of the node identifier out of the last received NM-message has failed NetworkHandle does not exist (development only) module not yet initialized (development only)
Description:	Get node identifier out of the last successfully received NM-message. The function <BusNm>_GetNodeIdentifier shall be called.	

Caveats of Nm_GetNodeIdentifier: The <BusNm> and the Nm itself are initialized correctly.

Configuration of Nm_GetNodeIdentifier: Optional (Only available if NmNodeIdEnabled is set to TRUE)

8.3.1.12 Nm_GetLocalNodeIdentifier

Nm040:

Service name:	Nm_GetLocalNodeIdentifier	
Syntax:	Nm_ReturnType Nm_GetLocalNodeIdentifier(const NetworkHandleType NetworkHandle, uint8 * const nmNodeIdPtr)	
Service ID[hex]:	0x0b	
Sync/Async:	Synchronous	
Reentrancy:	Non-reentrant for the same NetworkHandle, reentrant otherwise	
Parameters (in):	NetworkHandle	Identification of the NM-channel
Parameters (inout):	None	
Parameters (out):	nmNodeIdPtr	Pointer where node identifier of the local node shall be copied to
Return value:	Nm_ReturnType	NM_E_OK: No error NM_E_NOT_OK: Getting of the node identifier of the local node has failed NetworkHandle does not exist (development only) module not yet initialized (development only)
Description:	Get node identifier configured for the local node. For that purpose <BusNm>_GetLocalNodeIdentifier shall be called (e.g. CanNm_GetLocalNodeIdentifier function is called if channel is configured as CAN).	

Caveats of Nm_GetLocalNodeIdentifier: The <BusNm> and the Nm itself are initialized correctly.

Configuration of Nm_GetLocalNodeIdentifier: Optional (Only available if NmNodeIdEnabled is set to TRUE)

8.3.1.13 Nm_CheckRemoteSleepIndication

Nm042:

Service name:	Nm_CheckRemoteSleepIndication	
Syntax:	Nm_ReturnType Nm_CheckRemoteSleepIndication(const NetworkHandleType nmNetworkHandle, boolean * const nmRemoteSleepIndPtr)	
Service ID[hex]:	0x0d	
Sync/Async:	Synchronous	
Reentrancy:	Non-reentrant for the same NetworkHandle, reentrant otherwise	
Parameters (in):	nmNetworkHandle	Identification of the NM-channel
Parameters (inout):	None	
Parameters (out):	nmRemoteSleepIndPtr	Pointer where check result of remote sleep indication shall be copied to
Return value:	Nm_ReturnType	NM_E_OK: No error NM_E_NOT_OK: Checking of remote sleep indication bits has failed NetworkHandle does not exist (development only)

		module not yet initialized (development only) NM_E_NOT_EXECUTED: Checking of remote sleep indication bits has not executed
Description:	Check if remote sleep indication takes place or not. This in turn calls the <BusNm>_CheckRemoteSleepIndication for the bus specific NM layer (e.g. CanNm_CheckRemoteSleepIndication function is called if channel is configured as CAN).	

Caveats of Nm_CheckRemoteSleepIndication: The <BusNm> and the Nm itself are initialized correctly.

Configuration of Nm_CheckRemoteSleepIndication: Optional (Only available if NM_REMOTE_SLEEP_INDICATION_ENABLED is set to ON)

8.3.1.14 Nm_GetState

Nm043:

Service name:	Nm_GetState	
Syntax:	Nm_ReturnType Nm_GetState(const NetworkHandleType nmNetworkHandle, Nm_StateType* const nmStatePtr, Nm_ModeType* const nmModePtr)	
Service ID[hex]:	0x0e	
Sync/Async:	Synchronous	
Reentrancy:	Non-reentrant for the same NetworkHandle, reentrant otherwise	
Parameters (in):	nmNetworkHandle	Identification of the NM-channel
Parameters (inout):	None	
Parameters (out):	nmStatePtr	Pointer where state of the network management shall be copied to
	nmModePtr	Pointer to the location where the mode of the network management shall be copied to
Return value:	Nm_ReturnType	NM_E_OK: No error NM_E_NOT_OK: Getting of NM state has failed NetworkHandle does not exist (development only) module not yet initialized (development only)
Description:	Returns the state of the network management. This function in turn calls the <BusNm>_GetState function (e.g. CanNm_GetState function is called if channel is configured as CAN).	

Caveats of Nm_GetState: The <BusNm> and the Nm itself are initialized correctly.

Configuration of Nm_GetState: Mandatory

8.3.1.15 Nm_GetVersionInfo

Nm044:

Service name:	Nm_GetVersionInfo
Syntax:	void Nm_GetVersionInfo(

	Std_VersionInfoType* nmVerInfoPtr)	
Service ID[hex]:	0x0f	
Sync/Async:	Synchronous	
Reentrancy:	Reentrant	
Parameters (in):	None	
Parameters (inout):	None	
Parameters (out):	nmVerInfoPtr	Pointer to where to store the version information of this module.
Return value:	None	
Description:	<p>This service returns the version information of this module. The version information includes:</p> <ul style="list-style-type: none"> - Module Id - Vendor Id - Vendor specific version numbers (BSW00407). <p>Hint: If source code for caller and callee of this function is available this function should be realized as a macro. The macro should be defined in the modules header file.</p>	

Configuration of Nm_GetVersionInfo: Optional (only available if NmVersionInfoApi is set to ON)

8.4 Call-back notifications

Nm028 All callbacks shall assume that they can run either in task or in interrupt context.

8.4.1 Nm_NetworkStartIndication

Nm104:

Service name:	Nm_NetworkStartIndication	
Syntax:	<pre>void Nm_NetworkStartIndication(const NetworkHandleType nmNetworkHandle)</pre>	
Service ID[hex]:	0x00	
Sync/Async:	Synchronous	
Reentrancy:	Reentrant	
Parameters (in):	nmNetworkHandle	Identification of the NM-channel
Parameters (inout):	None	
Parameters (out):	None	
Return value:	None	
Description:	<p>Notification that a NM-message has been received in the Bus-Sleep Mode, what indicates that some nodes in the network have already entered the Network Mode. The callback function shall start the network management state machine.</p>	

Configuration of Nm_NetworkStartIndication: Mandatory

8.4.2 Nm_NetworkMode

Nm105:

Service name:	Nm_NetworkMode
Syntax:	void Nm_NetworkMode(const NetworkHandleType nmNetworkHandle)
Sync/Async:	Synchronous
Reentrancy:	Reentrant
Parameters (in):	nmNetworkHandle Identification of the NM-channel
Parameters (inout):	None
Parameters (out):	None
Return value:	None
Description:	Notification that the network management has entered Network Mode. The callback function shall enable transmission of application messages.

Configuration of Nm_NetworkMode: Mandatory

8.4.3 Nm_PrepareBusSleepMode

Nm106:

Service name:	Nm_PrepareBusSleepMode
Syntax:	void Nm_PrepareBusSleepMode(const NetworkHandleType nmNetworkHandle)
Sync/Async:	Synchronous
Reentrancy:	Reentrant
Parameters (in):	nmNetworkHandle Identification of the NM-channel
Parameters (inout):	None
Parameters (out):	None
Return value:	None
Description:	Notification that the network management has entered Prepare Bus-Sleep Mode. The callback function shall disable transmission of application messages.

Configuration of Nm_PrepareBusSleepMode: Mandatory

8.4.4 Nm_BusSleepMode

Nm107:

Service name:	Nm_BusSleepMode
Syntax:	void Nm_BusSleepMode(const NetworkHandleType nmNetworkHandle)
Sync/Async:	Synchronous
Reentrancy:	Reentrant

Parameters (in):	nmNetworkHandle	Identification of the NM-channel
Parameters (inout):	None	
Parameters (out):	None	
Return value:	None	
Description:	Notification that the network management has entered Bus-Sleep Mode.	

Configuration of Nm_BusSleepMode: Mandatory

8.4.5 Nm_PduRxIndication

Nm112:

Service name:	Nm_PduRxIndication	
Syntax:	<pre>void Nm_PduRxIndication(const NetworkHandleType nmNetworkHandle)</pre>	
Service ID[hex]:	0x00	
Sync/Async:	Synchronous	
Reentrancy:	Reentrant	
Parameters (in):	nmNetworkHandle	Identification of the NM-channel
Parameters (inout):	None	
Parameters (out):	None	
Return value:	None	
Description:	Notification that a NM message has been received.	

Configuration of Nm_PduRxIndication: Optional (only available if NmPduRxIndicationEnabled is set to TRUE)

8.4.6 Nm_StateChangeNotification

Nm114:

Service name:	Nm_StateChangeNotification	
Syntax:	<pre>void Nm_StateChangeNotification(const NetworkHandleType nmNetworkHandle, const Nm_StateType nmPreviousState, const Nm_StateType nmCurrentState)</pre>	
Service ID[hex]:	0x00	
Sync/Async:	Synchronous	
Reentrancy:	Reentrant	
Parameters (in):	nmNetworkHandle	Identification of the NM-channel
	nmPreviousState	Previous state of the NM-channel
	nmCurrentState	Current (new) state of the NM-channel
Parameters (inout):	None	
Parameters (out):	None	
Return value:	None	
Description:	Notification that the state of the lower layer <BusNm> has changed.	

Configuration of Nm_StateChangeNotification: Optional (only available if NmStateChangeIndEnabled is set to TRUE)

8.5 Scheduled functions

Nm020 A scheduled main function shall only be supplied for the NM coordinator functionality.

[**Nm121**: In case a main function exists and it is called before the NM Interface has been initialized, the main function shall immediately return without yielding an error.

8.5.1 Nm_MainFunction

Nm118:

Service name:	Nm_MainFunction
Syntax:	void Nm_MainFunction()
Service ID[hex]:	0x10
Timing:	FIXED_CYCLIC
Description:	This function implements the processes of the NM Interface, which need a fix cyclic scheduling. This function is supplied for the NM coordinator functionality (Nm020). However, specific implementation may not need it (Nm093)

Pre condition of Nm_MainFunction: NM Interface must be initialized before

8.6 Expected Interfaces

This chapter lists all interfaces required from other modules.

8.6.1 Mandatory Interfaces

This chapter lists all interfaces required from other modules.

Nm119:

API function	Description
CanNm_SetUserData	--
CanNm_StartTransmission	--
CanNm_TriggerTransmission	--
CanNm_Init	--
CanNm_GetVersionInfo	--
CanNm_MainFunction_<Instanceld>	--
CanNm_StartBusLoadReduction	--
CanNm_GetLocalNodeIdentifier	--
CanNm_GetNodeIdentifier	--
CanNm_StopBusLoadReduction	--
CanNm_GetPduData	--

CanNm_StopTransmission	--
CanNm_GetUserData	--
CanNm_SetRepeatMessageBit	--
ComM_Nm_NetworkStartIndication	Indication that a NM-message has been received in the Bus Sleep Mode, what indicates that some nodes in the network have already entered the Network Mode.
ComM_Nm_BusSleepMode	Notification that the network management has entered Bus-Sleep Mode. This callback function should perform a transition of the hardware and transceiver to bus-sleep mode.
ComM_Nm_PrepareBusSleepMode	Notification that the network management has entered Prepare Bus-Sleep Mode. Reentrant: Reentrant (but not for the same NM-Channel)
ComM_Nm_NetworkMode	Notification that the network management has entered Network Mode.
ComM_Nm_RestartIndication	If NmIf has started to shut down the coordinated busses, AND not all coordinated busses have indicated bus sleep state, AND on at least on one of the coordinated busses NM is restarted, THEN the NM Interface shall call the callback function ComM_Nm_RestartIndication with the nmNetworkHandle of the channels which have already indicated bus sleep state.
FrNm_GetNodeIdentifier	This function gets the node identifier from the last successfully received NM-message.
FrNm_CheckRemoteSleepIndication	This function checks if remote sleep indication has taken place or not.
FrNm_NetworkRequest	This function requests the network because the ECU needs to communicate on the bus. Network state shall be changed to 'requested'.
FrNm_SetUserData	This function sets user data for NM-Data transmitted next on the bus.
FrNm_GetPduData	Gets PDU data.
FrNm_RepeatMessageRequest	This function causes a Repeat Message Request to be transmitted next on the bus.
FrNm_GetVersionInfo	Returns the version information.
FrNm_RequestBusSynchronization	This function has no functionality - the service is provided only to be compatible to future extensions and to be compatible to the CAN-NM interface.
FrNm_NetworkRelease	This function releases the network because the ECU doesn't have to communicate on the bus. Network state shall be changed to 'released'.
FrNm_MainFunction_<NmClstIdx>	Main function of FlexRay NM.
FrNm_PassiveStartUp	Initiates the Passive Startup of the FlexRay NM.
FrNm_Init	Initializes the FlexRay NM and its internal state machine.
FrNm_GetUserData	This function gets user data from the last successfully received NM message.
FrNm_GetState	This function returns the state and the mode of the network management.
FrNm_GetLocalNodeIdentifier	This function gets the node identifier configured for the local node.

9 Sequence diagrams

The role of the NM Interface module is to act as a dispatcher of functions.

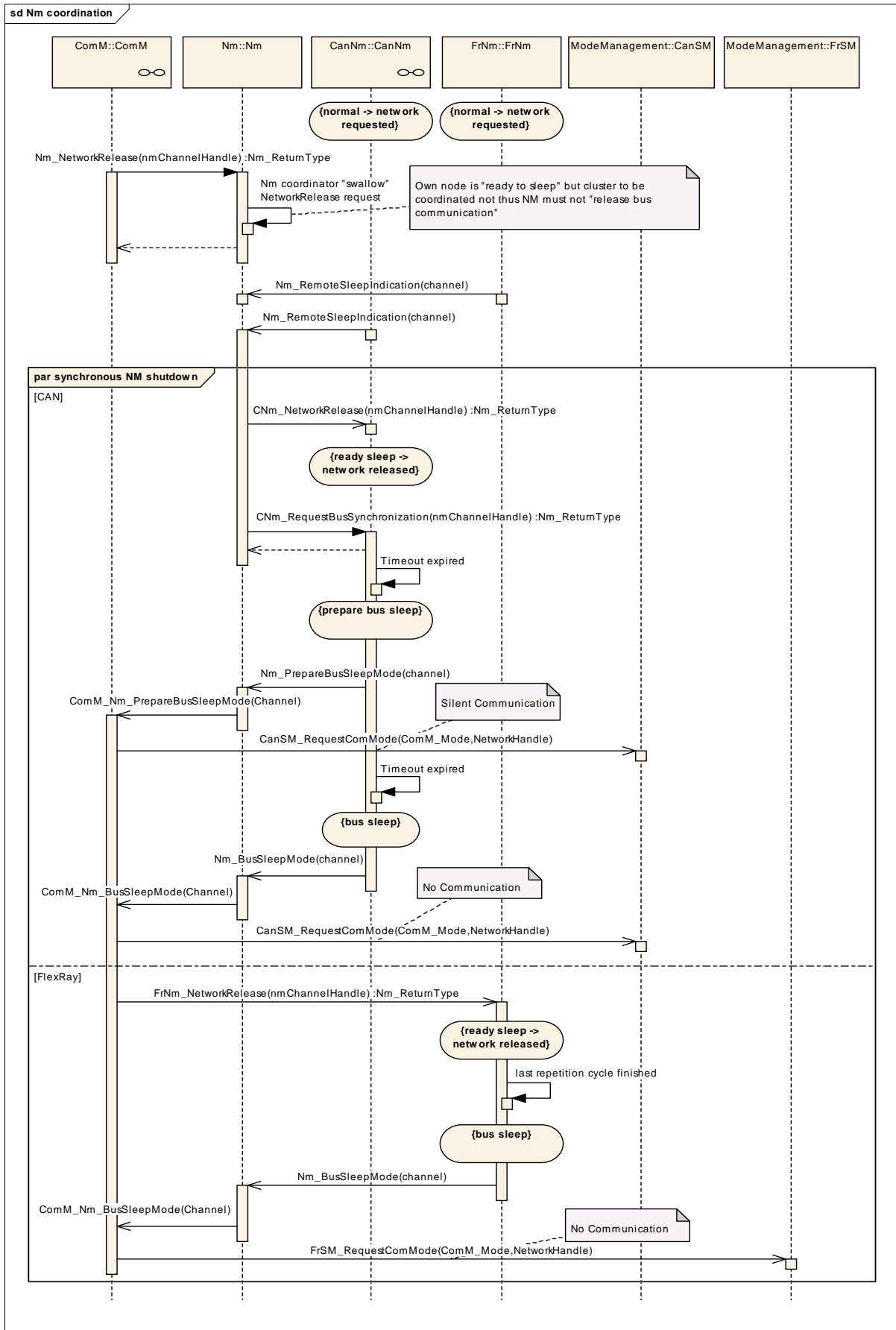

Figure 9.1

10 Configuration specification

The following chapter contains tables of all configuration parameters and switches used to determine the functional units of the Generic Network Management Interface. The default values of configuration parameters are denoted as bold.

In general, this chapter defines configuration parameters and their clustering into containers. In order to support the specification Chapter 10.1 describes fundamentals. It also specifies a template (table) you shall use for the parameter specification. Chapter 10.2 specifies the structure (containers) and the parameters of the module <Module Name>. Chapter 10.3 specifies published information of the module <Module Name>.

10.1 How to read this chapter

In addition to this section, it is highly recommended to read the documents:

- AUTOSAR Layered Software Architecture
- AUTOSAR ECU Configuration Specification
This document describes the AUTOSAR configuration methodology and the AUTOSAR configuration meta model in detail.

The following is only a short survey of the topic and it will not replace the ECU Configuration Specification document.

10.1.1 Configuration and configuration parameters

Configuration parameters define the variability of the generic part(s) of an implementation of a module. This means that only generic or configurable module implementation can be adapted to the environment (software/hardware) in use during system and/or ECU configuration.

The configuration of parameters can be achieved at different times during the software process: before compile time, before link time or after build time. In the following, the term “configuration class” (of a parameter) shall be used in order to refer to a specific configuration point in time.

10.1.2 Variants

Variants describe sets of configuration parameters. E.g., variant 1: only pre-compile time configuration parameters, variant 2: mix of pre-compile- and post build time-configuration parameters. In one variant, a parameter can only be of one configuration class.

10.1.3 Containers

Containers structure the set of configuration parameters. This means:

- *all* configuration parameters are kept in containers.
- (sub-) containers can reference (sub-) containers. It is possible to assign a multiplicity to these references. The multiplicity then defines the possible number of instances of the contained parameters.

10.2 Containers and configuration parameters

The configuration parameters as defined in this chapter are used to create a data model for an AUTOSAR tool chain. The realization in the code is implementation specific.

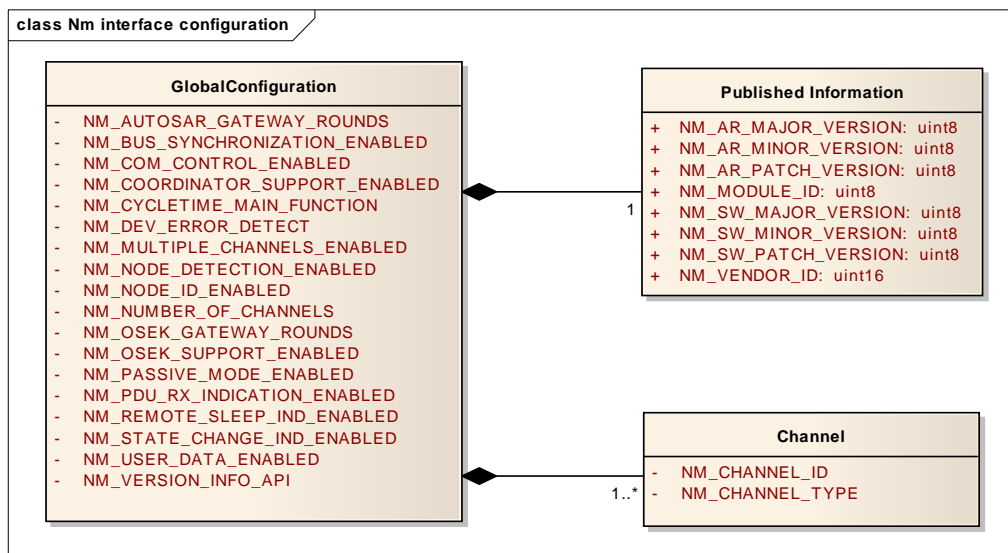

Figure 10.1

Figure 10.1 specifies all configurable parameters in this module.

10.2.1 Variants

Nm120: Variant 1: All configuration parameters are configurable at pre-compile time.

Use case: Source code optimizations

Variant 2: not supported

Variant 3: not supported

10.2.2

Nm

Module Name	Nm
-------------	----

Module Description	The Generic Network Management Interface module
---------------------------	---

Included Containers		
Container Name	Multiplicity	Scope / Dependency
NmGlobalConfig	1	This container contains all global configuration parameters of the Nm Interface.

10.2.3 NmGlobalConfig

SWS Item	--
Container Name	NmGlobalConfig{Nm_GlobalConfig}
Description	This container contains all global configuration parameters of the Nm Interface.
Configuration Parameters	

SWS Item	--		
Name	NmAutosarGatewayRounds {NM_AUTOSAR_GATEWAY_ROUNDS}		
Description	Number of rounds the coordinator shall keep a bus which runs AUTOSAR NM awake after all nodes including itself are ready to sleep.		
Multiplicity	1		
Type	IntegerParamDef		
Default value	--		
ConfigurationClass	Pre-compile time	X	All Variants
	Link time	--	
	Post-build time	--	
Scope / Dependency	scope: Module dependency: The number is the same for all coordinated AUTOSAR busses. Only valid if NM_COORDINATOR_SUPPORT_ENABLED is set to TRUE.		

SWS Item	--		
Name	NmBusSynchronizationEnabled {NM_BUS_SYNCHRONIZATION_ENABLED}		
Description	Pre-processor switch for enabling bus synchronization support. This feature is required for gateway nodes only.		
Multiplicity	1		
Type	BooleanParamDef		
Default value	--		
ConfigurationClass	Pre-compile time	X	All Variants
	Link time	--	
	Post-build time	--	
Scope / Dependency	scope: Module dependency: It must not be enabled if NmPassiveModeEnabled is enabled.		

SWS Item	--		
Name	NmComControlEnabled {NM_COM_CONTROL_ENABLED}		
Description	Pre-processor switch for enabling the Communication Control support.		
Multiplicity	1		
Type	BooleanParamDef		
Default value	--		
ConfigurationClass	Pre-compile time	X	All Variants

	Link time	--	
	Post-build time	--	
Scope / Dependency	scope: Module dependency: The parameter CNM_COM_CONTROL_ENABLED shall be derived from this.		

SWS Item	--		
Name	NmCoordinatorSupportEnabled {NM_COORDINATOR_SUPPORT_ENABLED}		
Description	Switch to inform if NM coordinator needs to be supported.		
Multiplicity	1		
Type	BooleanParamDef		
Default value	false		
ConfigurationClass	Pre-compile time	X	All Variants
	Link time	--	
	Post-build time	--	
Scope / Dependency	scope: Module dependency: Only valid if NM_REMOTE_SLEEP_IND_ENABLED is set to TRUE.		

SWS Item	--		
Name	NmCycletimeMainFunction {NM_CYCLETIME_MAIN_FUNCTION}		
Description	The period between successive calls to the Main Function of the NM Interface in seconds.		
Multiplicity	1		
Type	FloatParamDef		
Default value	--		
ConfigurationClass	Pre-compile time	X	All Variants
	Link time	--	
	Post-build time	--	
Scope / Dependency	scope: Module dependency: Only valid if NM_COORDINATOR_SUPPORT_ENABLED is set to TRUE. If coordinator support enabled and NM_CYCLE_MAIN_FUNCTION is not set, it shall be assumed that the specific implementation needs no main function.		

SWS Item	--		
Name	NmDevErrorDetect {NM_DEV_ERROR_DETECT}		
Description	Pre-processor switch for enabling development error detection and notification.		
Multiplicity	1		
Type	BooleanParamDef		
Default value	false		
ConfigurationClass	Pre-compile time	X	All Variants
	Link time	--	
	Post-build time	--	
Scope / Dependency	scope: Module		

SWS Item	--		
Name	NmMultipleChannelsEnabled {NM_MULTIPLE_CHANNELS_ENABLED}		
Description	Pre-processor switch for enabling channel multiplicity support.		
Multiplicity	1		
Type	BooleanParamDef		
Default value	false		

ConfigurationClass	Pre-compile time	X	All Variants
	Link time	--	
	Post-build time	--	
Scope / Dependency	scope: Module		

SWS Item	--		
Name	NmNodeDetectionEnabled {NM_NODE_DETECTION_ENABLED}		
Description	Pre-processor switch for enabling the Request Repeat Message Request support.		
Multiplicity	1		
Type	BooleanParamDef		
Default value	--		
ConfigurationClass	Pre-compile time	X	All Variants
	Link time	--	
	Post-build time	--	
Scope / Dependency	scope: Module dependency: Only valid if NM_NODE_ID_ENABLED is set to TRUE		

SWS Item	--		
Name	NmNodeIdEnabled {NM_NODE_ID_ENABLED}		
Description	Pre-processor switch for enabling the source node identifier.		
Multiplicity	1		
Type	BooleanParamDef		
Default value	--		
ConfigurationClass	Pre-compile time	X	All Variants
	Link time	--	
	Post-build time	--	
Scope / Dependency	scope: Module		

SWS Item	--		
Name	NmNumberOfChannels {NM_NUMBER_OF_CHANNELS}		
Description	Number of NM channels allowed within one ECU.		
Multiplicity	1		
Type	IntegerParamDef		
Range	1 .. 255		
Default value	--		
ConfigurationClass	Pre-compile time	X	All Variants
	Link time	--	
	Post-build time	--	
Scope / Dependency	scope: Module		

SWS Item	--		
Name	NmOsekGatewayRounds {NM_OSEK_GATEWAY_ROUNDS}		
Description	Number of rounds the coordinator shall keep a bus which runs OSEK NM awake after all nodes including itself are ready to sleep.		
Multiplicity	1		
Type	IntegerParamDef		
Default value	--		
ConfigurationClass	Pre-compile time	X	All Variants
	Link time	--	
	Post-build time	--	
Scope / Dependency	scope: Module dependency: The number is the same for all coordinated OSEK busses. Only valid if NM_OSEK_SUPPORT_ENABLED is set to TRUE.		

SWS Item	--		
Name	NmOsekSupportEnabled {NM_OSEK_SUPPORT_ENABLED}		
Description	Switch to inform if NM coordinator needs to support direct OSEK NM.		
Multiplicity	1		
Type	BooleanParamDef		
Default value	false		
ConfigurationClass	Pre-compile time	X	All Variants
	Link time	--	
	Post-build time	--	
Scope / Dependency	scope: Module dependency: Only valid if NM_COORDINATOR_SUPPORT_ENABLED		

SWS Item	--		
Name	NmPassiveModeEnabled {NM_PASSIVE_MODE_ENABLED}		
Description	Pre-processor switch for enabling support of the Passive Mode.		
Multiplicity	1		
Type	BooleanParamDef		
Default value	--		
ConfigurationClass	Pre-compile time	X	All Variants
	Link time	--	
	Post-build time	--	
Scope / Dependency	scope: Module		

SWS Item	--		
Name	NmPduRxIndicationEnabled {NM_PDU_RX_INDICATION_ENABLED}		
Description	Pre-processor switch for enabling the PDU Rx Indication.		
Multiplicity	1		
Type	BooleanParamDef		
Default value	--		
ConfigurationClass	Pre-compile time	X	All Variants
	Link time	--	
	Post-build time	--	
Scope / Dependency	scope: Module dependency: The CNM_PDU_RX_INDICATION_ENABLED shall be derived from this parameter.		

SWS Item	--		
Name	NmRemoteSleepIndEnabled {NM_REMOTE_SLEEP_IND_ENABLED}		
Description	Pre-processor switch for enabling remote sleep indication support. This feature is required for gateway nodes only.		
Multiplicity	1		
Type	BooleanParamDef		
Default value	--		
ConfigurationClass	Pre-compile time	X	All Variants
	Link time	--	
	Post-build time	--	
Scope / Dependency	scope: Module dependency: It must not be enabled if NmPassiveModeEnabled is enabled.		

SWS Item	--		
Name	NmStateChangeIndEnabled {NM_STATE_CHANGE_IND_ENABLED}		
Description	Pre-processor switch for enabling the CAN Network Management state		

	change notification.		
Multiplicity	1		
Type	BooleanParamDef		
Default value	--		
ConfigurationClass	Pre-compile time	X	All Variants
	Link time	--	
	Post-build time	--	
Scope / Dependency	scope: Module dependency: The parameters CNM_STATE_CHANGE_IND_ENABLED and FRNM_STATE_CHANGE_IND_ENABLED shall be derived from this parameter.		

SWS Item	--		
Name	NmUserDataEnabled {NM_USER_DATA_ENABLED}		
Description	Pre-processor switch for enabling user data support.		
Multiplicity	1		
Type	BooleanParamDef		
Default value	--		
ConfigurationClass	Pre-compile time	X	All Variants
	Link time	--	
	Post-build time	--	
Scope / Dependency	scope: Module		

SWS Item	--		
Name	NmVersionInfoApi {NM_VERSION_INFO_API}		
Description	Pre-processor switch for enabling version info API support.		
Multiplicity	1		
Type	BooleanParamDef		
Default value	--		
ConfigurationClass	Pre-compile time	X	All Variants
	Link time	--	
	Post-build time	--	
Scope / Dependency	scope: Module		

Included Containers		
Container Name	Multiplicity	Scope / Dependency
NmChannelConfig	1..*	This container contains the configuration (parameters) of the bus channel(s). The channel parameter shall be harmonized within the whole communication stack.

Nm083 The Global Scope specifies configuration parameters that shall be defined in the module's configuration header file `Nm_cfg.h`.

10.2.4 NmChannelConfig

SWS Item	--		
Container Name	NmChannelConfig{Channel}		
Description	This container contains the configuration (parameters) of the bus channel(s). The channel parameter shall be harmonized within the whole communication stack.		
Configuration Parameters			

SWS Item	--		
Name	NmBusType {NM_BUS_TYPE}		
Description	Identifies the bus type of the channel. LIN is not yet supported.		
Multiplicity	1		
Type	EnumerationParamDef		
Range	NM_BUS_TYPE_CAN	CAN bus	
	NM_BUS_TYPE_FR	FlexRay bus	
	NM_BUS_TYPE_LIN	LIN bus. Not yet supported!	
ConfigurationClass	Pre-compile time	X	All Variants
	Link time	--	
	Post-build time	--	
Scope / Dependency	scope: ECU		

SWS Item	--		
Name	NmChannelId {NM_CHANNEL_ID}		
Description	Channel identification number of the corresponding channel.		
Multiplicity	1		
Type	IntegerParamDef (Symbolic Name generated for this parameter)		
Range	0 .. 255		
Default value	--		
ConfigurationClass	Pre-compile time	X	All Variants
	Link time	--	
	Post-build time	--	
Scope / Dependency	scope: ECU dependency: Shall be harmonized with channel IDs of the whole communication stack.		

SWS Item	--		
Name	NmComMChannelRef		
Description	Reference to the corresponding ComM Channel.		
Multiplicity	1		
Type	Reference to ComMChannel		
ConfigurationClass	Pre-compile time	X	All Variants
	Link time	--	
	Post-build time	--	
Scope / Dependency			

No Included Containers

10.3 Published Information

Published information contains data defined by the implementer of the SW module that does not change when the module is adapted (i.e. configured) to the actual HW/SW environment. It thus contains version and manufacturer information.

Nm008 The following table specifies configuration parameters that shall be published in the module's header file `Nm.h` and also in the module's description file.

The standard common published information like

```
vendorId (<Module>_VENDOR_ID),  
moduleId (<Module>_MODULE_ID),  
arMajorVersion (<Module>_AR_MAJOR_VERSION),  
arMinorVersion (<Module>_AR_MINOR_VERSION),  
arPatchVersion (<Module>_AR_PATCH_VERSION),  
swMajorVersion (<Module>_SW_MAJOR_VERSION),  
swMinorVersion (<Module>_SW_MINOR_VERSION),  
swPatchVersion (<Module>_SW_PATCH_VERSION),  
vendorApiInfix (<Module>_VENDOR_API_INFIX)
```

is provided in the BSW Module Description Template (see [8] Figure 4.1 and Figure 7.1).

Additional published parameters are listed below if applicable for this module.

11 Changes to Release 1

This specification did not exist in Release 1. Therefore, chapters 11.1 – 11.4 are not applicable. However, they are kept for further versions.

11.1 Deleted SWS Items

<i>SWS Item</i>	<i>Rationale</i>

11.2 Replaced SWS Items

<i>SWS Item of Release 1</i>	<i>replaced by SWS Item</i>	<i>Rationale</i>

11.3 Changed SWS Items

<i>SWS Item</i>	<i>Rationale</i>

11.4 Added SWS Items

<i>SWS Item</i>	<i>Rationale</i>

12 Changes during SWS Improvements by Technical Office

12.1 Deleted SWS Items

None

12.2 Replaced SWS Items

None

12.3 Changed SWS Items

None

12.4 Added SWS Items

SWS Item	Rationale
NM117	UML model linking of imported types
Nm118	UML model linking of Nm_MainFunction
Nm119	UML model linking of Mandatory Interfaces
Nm120	Each variant gets an individual requirement ID