

Document Title	Specification of CAN Transport Layer
Document Owner	AUTOSAR
Document Responsibility	AUTOSAR
Document Identification No	014
Document Classification	Standard

Document Version	2.3.0
Document Status	Final
Part of Release	3.0
Revision	7

Document Change History			
Date	Version	Changed by	Change Description
15.09.2010	2.3.0	AUTOSAR Administration	<ul style="list-style-type: none"> • Removed CanTp228 • Updated CanTp246, CanTp248 • Legal disclaimer revised
03.12.2007	2.2.0	AUTOSAR Administration	<ul style="list-style-type: none"> • Addition of transmit cancellation feature • DataLength check only for too small DLC (CanTp220) • Restriction on mapping of N-Pdu (CanTp248) • Document meta information extended • Small layout adaptations made
24.01.2007	2.1.1	AUTOSAR Administration	<ul style="list-style-type: none"> • “Advice for users” revised • “Revision Information” added
04.12.2006	2.1.0	AUTOSAR Administration	<ul style="list-style-type: none"> • Clarification and correction of error management: list of production/development error and behavior in case of error • Addition of CanTp166 and CanTp167 to avoid blocking situation in case of no buffer provided by upper layer • Remove of CanTpRxWftMax of container CanTpTxNSdu • 1 parameter added for the call of Det_ReportError • Add header files inclusions • Addition of CanTpNSa container in configuration chapter • Legal disclaimer revised
27.04.2006	2.0.0	AUTOSAR Administration	Document structure adapted to common Release 2.0 SWS Template.

Document Change History

Date	Version	Changed by	Change Description
21.06.2005	1.0.0	AUTOSAR Administration	Initial Release

Disclaimer

This specification and the material contained in it, as released by AUTOSAR is for the purpose of information only. AUTOSAR and the companies that have contributed to it shall not be liable for any use of the specification.

The material contained in this specification is protected by copyright and other types of Intellectual Property Rights. The commercial exploitation of the material contained in this specification requires a license to such Intellectual Property Rights.

This specification may be utilized or reproduced without any modification, in any form or by any means, for informational purposes only.
For any other purpose, no part of the specification may be utilized or reproduced, in any form or by any means, without permission in writing from the publisher.

The AUTOSAR specifications have been developed for automotive applications only. They have neither been developed, nor tested for non-automotive applications.

The word AUTOSAR and the AUTOSAR logo are registered trademarks.

Advice for users

AUTOSAR Specification Documents may contain exemplary items (exemplary reference models, "use cases", and/or references to exemplary technical solutions, devices, processes or software).

Any such exemplary items are contained in the Specification Documents for illustration purposes only, and they themselves are not part of the AUTOSAR Standard. Neither their presence in such Specification Documents, nor any later documentation of AUTOSAR conformance of products actually implementing such exemplary items, imply that intellectual property rights covering such exemplary items are licensed under the same rules as applicable to the AUTOSAR Standard.

Table of Contents

1	Introduction and functional overview	7
2	Acronyms and abbreviations	10
3	Related documentation.....	13
3.1	Input documents.....	13
3.2	Related standards and norms	14
4	Constraints and assumptions	15
4.1	Limitations	15
4.2	Applicability in automotive domain	15
5	Dependencies on other modules.....	16
5.1	AUTOSAR architecture basic concepts.....	16
5.1.1	CAN Transport Layer connection(s).....	16
5.1.2	CAN Transport Layer interactions	16
5.1.3	Processing mode	17
5.1.4	Data consistency.....	17
5.1.5	Static configuration.....	17
5.1.6	PDU Router services.....	18
5.1.7	CAN Interface services	18
5.2	File structure	18
5.2.1	Code file structure	18
5.2.2	Header file structure.....	18
5.2.3	Design Rules.....	20
6	Requirements traceability	21
7	Functional specification	27
7.1	Services provided to upper layer	27
7.1.1	Initialization and shutdown	27
7.1.2	Transmit request	29
7.1.3	Transmit cancellation	29
7.2	Services provided to the lower layer.....	30
7.2.1	Transmit confirmation.....	30
7.2.2	Reception indication.....	30
7.3	Internal behavior.....	31
7.3.1	N-SDU Reception.....	31
7.3.2	N-SDU Transmission	33
7.3.3	Buffer strategy.....	35
7.3.4	No Protocol parameter setting services	39
7.3.5	Tx and Rx data flow	39
7.3.6	Relationship between CAN NSduld and CAN LSduld.....	40
7.3.7	Concurrent connection	41
7.3.8	N-PDU padding.....	42
7.3.9	Handling of unexpected N-PDU arrival	43
7.4	Error classification	44
7.5	Error detection.....	46
7.6	Error notification	46

8	API specification.....	49
8.1	Imported types.....	49
8.2	Type definitions	49
8.2.1	CanTp_CancelReasonType.....	49
8.3	Function definitions	50
8.3.1	CanTp_Init.....	50
8.3.2	CanTp_GetVersionInfo	50
8.3.3	CanTp_Shutdown	51
8.3.4	CanTp_Transmit	52
8.3.5	Main Function.....	54
8.4	Call-back notifications	54
8.4.1	CanTp_RxIndication.....	55
8.4.2	CanTp_TxConfirmation	55
8.5	Expected Interfaces.....	56
8.5.1	Mandatory Interfaces	56
8.5.2	Optional Interfaces	56
9	Sequence diagrams	57
9.1	SF N-SDU received and no buffer provided	57
9.1.1	Assumptions.....	57
9.1.2	Sequence diagram	57
9.1.3	Transition description	58
9.2	Successful SF N-PDU reception	59
9.2.1	Assumptions.....	59
9.2.2	Sequence diagram	59
9.2.3	Transition description	60
9.3	Transmit request of SF N-SDU	60
9.3.1	Assumptions.....	60
9.3.2	Sequence diagram	61
9.3.3	Transition description	62
9.4	Transmit request of larger N-SDU	63
9.4.1	Assumptions.....	63
9.4.2	Sequence diagram	64
9.4.3	Transition description	65
9.5	Large N-SDU Reception.....	66
9.5.1	Assumptions.....	66
9.5.2	Sequence diagram	67
9.5.3	Transition description	68
10	Configuration specification.....	69
10.1	How to read this chapter	69
10.1.1	Configuration and configuration parameters	69
10.1.2	Variants.....	69
10.1.3	Containers.....	70
10.1.4	Specification template for configuration parameters	70
10.2	Containers and configuration parameters	72
10.2.1	Variants.....	72
10.2.2	CanTp	72
10.2.3	CanTpGeneral.....	72
10.2.4	CanTpRxNSdu	73

10.2.5	CanTpRxNPdu	76
10.2.6	CanTpTxFcNPdu	77
10.2.7	CanTpTxNSdu	77
10.2.8	CanTpTxNPdu	80
10.2.9	CanTpRxFcNPdu	80
10.2.10	CanTpNTa	81
10.2.11	CanTpNSa	81
10.3	Published Information	82
11	Changes to Release 1	83
11.1	Deleted SWS Items	83
11.2	Replaced SWS Items	83
11.3	Changed SWS Items	84
11.4	Added SWS Items	84
12	Changes during SWS Improvements by Technical Office	86
12.1	Deleted SWS Items	86
12.2	Replaced SWS Items	86
12.3	Changed SWS Items	86
12.4	Added SWS Items	86

1 Introduction and functional overview

This specification defines the functionality, API and the configuration of the AUTOSAR Basic Software module CAN Transport Layer (CanTp).

CanTp is the module between the PDU Router and the CAN Interface module (see Figure 1). The main purpose of the CAN TP module is to segment and reassemble CAN I-PDUs longer than 8 bytes.

The PDU Router deploys AUTOSAR COM and DCM I-PDUs onto different communication protocols. The routing through a network system type (e.g. CAN, LIN and FlexRay) depends on the I-PDU identifier. The PDU Router also determines if a transport protocol has to be used or not. Lastly, this module carries out gateway functionality, when there is no rate conversion.

CAN Interface (CanIf) provides equal mechanisms to access a CAN bus channel regardless of its location (μ C internal/external). From the location of CAN controllers (on chip / onboard), it extracts the ECU hardware layout and the number of CAN drivers. Because CanTp only handles transport protocol frames (i.e. SF, FF, CF and FC PDUs), depending on the N-PDU ID, the CAN Interface has to forward an I-PDU to CanTp or PduR.

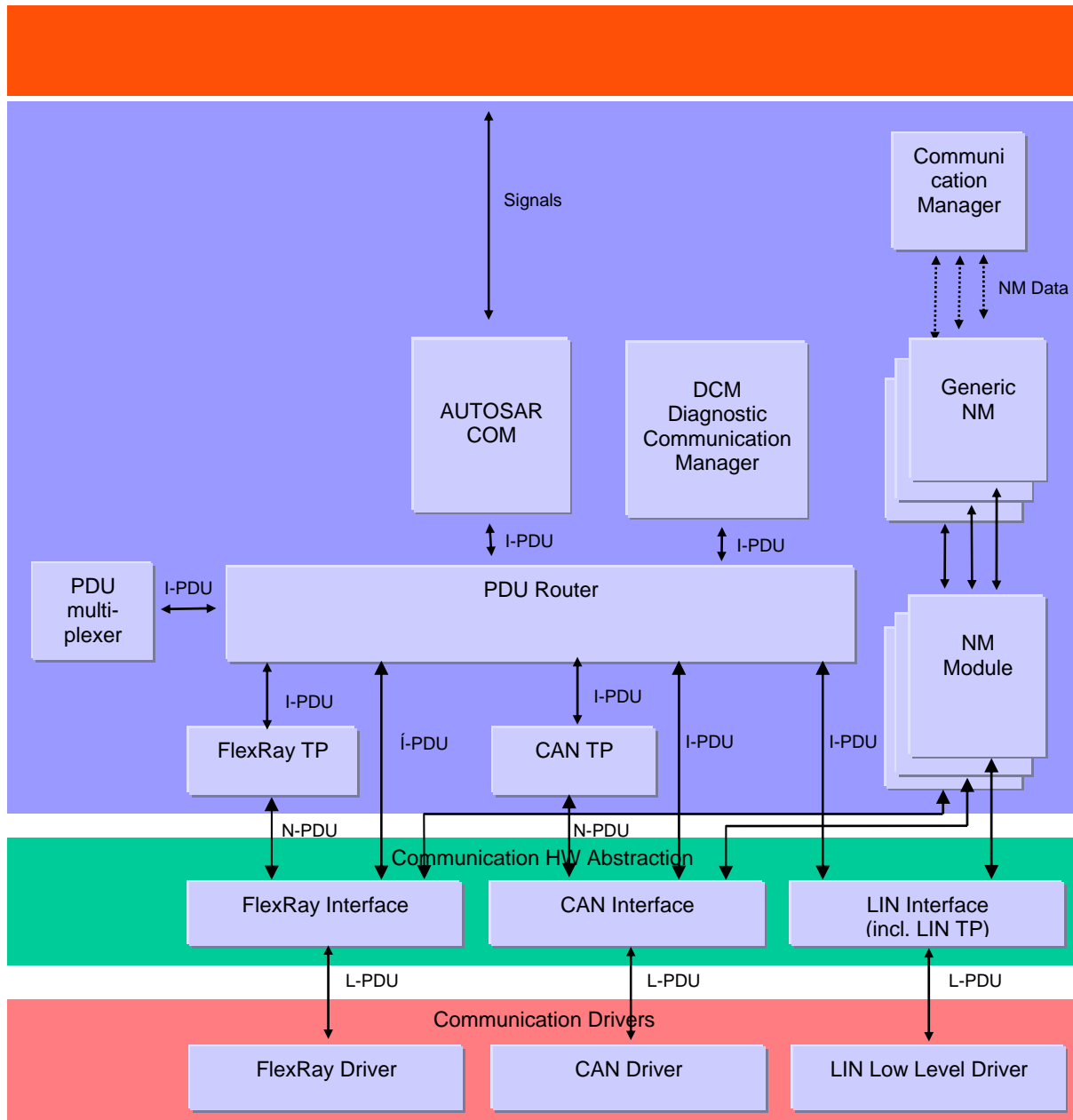

Figure 1 : AUTOSAR Communication Stack

According to AUTOSAR basic software architecture, CanTp provides services for:

- Segmentation of data in transmit direction;
- Reassembling of data in receive direction;
- Control of data flow;
- Detection of errors in segmentation sessions.
- Transmit cancellation

It is an AUTOSAR decision to base basic software module specifications on existing standards, thus this AUTOSAR CAN Transport Layer specification is based on the international standard ISO 15765, which is the most used standard in the automotive domain.

ISO 15765 (containing four sections) describes two applicable CAN Transport Layer specifications: ISO 15765-2 for OEM enhanced diagnostics [13] and ISO 15765-4 for OBD diagnostics [15]. Concerning the transport layer, ISO 15765-4 (the section of ISO 15765 which also covers the data link layer and physical layer) is in accordance with ISO 15765-2 with some restrictions/additions. In order that there is no incompatibility problem between ISO 15765-2 and ISO 15765-4, differences will be solved by the CAN Transport Layer configuration.

Although CAN transport protocol is mainly used for vehicle diagnostic systems, it has also been developed to deal with requirements from other CAN based systems requiring a transport layer protocol.

2 Acronyms and abbreviations

The prefix notation used in this document, is as follows:

Prefix:	Description:
I-	Relative to AUTOSAR COM Interaction Layer
L-	Relative to the CAN Interface module which is equivalent to the Logical Link Control (the upper part of the Data Link Layer – the lower part is called Media Access Control)
N-	Relative to the CAN Transport Layer which is equivalent to the OSI Network Layer.

All acronyms and abbreviations, which are specific to the CAN Transport Layer and are therefore not contained in the AUTOSAR glossary, are described in the following:

Acronym:	Description:
CAN L-SDU	This is the SDU of the CAN Interface module. It is similar to CAN N-PDU but from the CAN Interface module point of view.
CAN LSdul	This is the unique identifier of a SDU within the CAN Interface. It is used for referencing L-SDU's routing properties. Consequently, in order to interact with the CAN Interface through its API, an upper layer uses CAN LSdul to refer to a CAN L-SDU Info Structure.
CAN N-PDU	This is the PDU of the CAN Transport Layer. It contains a unique identifier, data length and data (protocol control information plus the whole N-SDU or a part of it).
CAN N-SDU	This is the SDU of the CAN Transport Layer. In the AUTOSAR architecture, it is a set of data coming from the PDU Router.
CAN N-SDU Info Structure	This is a CAN Transport Layer internal constant structure that contains specific CAN Transport Layer information to process transmission, reception, segmentation and reassembly of the related CAN N-SDU.
CAN NSdul	Unique SDU identifier within the CAN Transport Layer. It is used to reference N-SDU's routing properties. Consequently, to interact with the CAN Transport Layer via its API, an upper layer uses CAN NSdul to refer to a CAN N-SDU Info Structure.
I-PDU	This is the PDU of the AUTOSAR COM module.
PDU	In layered systems, it refers to a data unit that is specified in the protocol of a given layer. This contains user data of that layer (SDU) plus possible protocol control information. Furthermore, the PDU of layer X is the SDU of its lower layer X-1 (i.e. (X)-PDU = (X-1)-SDU).
PdulInfoType	This type refers to a structure used to store basic information to process the transmission/reception of a PDU (or a SDU), namely an pointer to its payload in RAM and the corresponding length (in bytes).
SDU	In layered systems, this refers to a set of data that is sent by a user of the services of a given layer, and is transmitted to a peer service user, whilst remaining semantically unchanged.

Abbreviation:	Description:
BS	Block Size
Can	CAN Driver module
CAN CF	CAN Consecutive Frame N-PDU
CAN FC	CAN Flow Control N-PDU
CAN FF	CAN First Frame N-PDU
CAN SF	CAN Single Frame N-PDU

Abbreviation:	Description:
CanIf	CAN Interface
CanTp	CAN Transport Layer
CanTrcv	CAN Transceiver module
CF	See "CAN CF"
Com	AUTOSAR COM module
Dcm	Diagnostic Communication Manager module
DEM	Diagnostic Event Manager
DET	Development Error Tracer
DLC	Data Length Code (part of CAN PDU that describes the SDU length)
FC	See "CAN FC"
FF	See "CAN FF"
FIM	Function Inhibition Manager
Mtype	Message Type (possible value: diagnostics, remote diagnostics)
N_AI	Network Address Information (see ISO 15765-2).
N_Ar	Time for transmission of the CAN frame (any N-PDU) on the receiver side (see ISO 15765-2).
N_As	Time for transmission of the CAN frame (any N-PDU) on the sender side (see ISO 15765-2).
N_Br	Time until transmission of the next flow control N-PDU (see ISO 15765-2).
N_Bs	Time until reception of the next flow control N-PDU (see ISO 15765-2).
N_Cr	Time until reception of the next consecutive frame N-PDU (see ISO 15765-2).
N-Cs	Time until transmission of the next consecutive frame N-PDU (see ISO 15765-2).
N_Data	Data information of the transport layer
N_PCI	Protocol Control Information of the transport layer
N_SA	Network Source Address (see ISO 15765-2).
N_TA	Network Target Address (see ISO 15765-2).
N_TAtype	Network Target Address type (see ISO 15765-2).
OBD	On-Board Diagnostic
PDU	Protocol Data Unit
PduR	PDU Router
SDU	Service Data Unit

The following table contains some of the concepts, which are useful in this work:

Definitions:	Description:
Development Error Tracer	The Development Error Tracer is merely a support to SW development and integration and is <u>not</u> contained in the production code. The API is defined, but the functionality can be chosen and implemented by the developer according to his specific needs.
Diagnostic Event Manager	The Diagnostic Event Manager is a standard AUTOSAR module which is available in the production code and whose functionality is specified in the AUTOSAR project.
Extended addressing format	A unique CAN identifier is assigned to each combination of N_SA, N_TAtype and Mtype. N_TA is filed in the first data byte of the CAN frame data field. N_PCI and N_Data are filed in the remaining bytes of the CAN frame data field.
Full-duplex	Point-to-point communication between two nodes is possible in both directions at any one time.
Function Inhibition Manager	The Function Inhibition Manager (FIM) stands for the evaluation and assignment of events to the required actions for Software Components (e.g. inhibition of specific "monitoring functions"). The DEM informs and updates the Function Inhibition Manager (FIM) upon changes of the event status in order to stop or release functional entities according to assigned dependencies. An interface to the functional entities is defined and supported by the Mode Manager. The FIM is not part of the DEM.

Definitions:	Description:
Functional addressing	<p>In the transport layer, functional addressing refers to N-SDU, of which parameter N_TAtype (which is an extension to the N_TA parameter [13] used to encode the communication model) has the value <i>functional</i>.</p> <p>This means the N-SDU is used in 1 to n communications. Thus with the CAN protocol, functional addressing will only be supported for Single Frame communication.</p> <p>In terms of application, functional addressing is used by the external (or internal) tester if it does not know the physical address of an ECU that should respond to a service request or if the functionality of the ECU is implemented as a distributed server over several ECUs. When functional addressing is used, the communication is a communication broadcast from the external tester to one or more ECUs (1 to n communication).</p> <p>Use cases are (for example) broadcasting messages, such as “ECUReset” or “CommunicationControl”</p> <p>OBd communication will always be performed as part of functional addressing.</p>
Half-duplex	Point-to-point communication between two nodes is only possible in one direction at a time.
Multiple connection	The CAN Transport Layer should manage several transport protocol communication sessions at a time.
Normal addressing format	A unique CAN identifier is assigned to each combination of N_SA, N_TA, N_TAtype and Mtype. N_PCI and N_Data are filed in the CAN frame data field.
Physical addressing	<p>In the transport layer, physical addressing refers to N-SDU, of which parameter N_TAtype (which is an extension of the N_TA parameter [13] used to encode the communication model) has the value <i>physical</i>.</p> <p>This means the N-SDU is used in 1 to 1 communication, thus physical addressing will be supported for all types of network layer messages.</p> <p>In terms of application, physical addressing is used by the external (or internal) tester if it knows the physical address of an ECU that should respond to a service request. When physical addressing is used, a point to point communication takes place (1 to 1 communication).</p> <p>Use cases are (for example) messages, such as “ReadDataByIdentifier” or “InputOutputControlByIdentifier”</p>
Single connection	The CAN Transport Layer will only manage one transport protocol communication session at a time.

3 Related documentation

3.1 Input documents

- [1] List of Basic Software Modules,
AUTOSAR_BasicSoftwareModules.pdf
- [2] Layered Software Architecture,
AUTOSAR_LayeredSoftwareArchitecture.pdf
- [3] General Requirements on Basic Software Modules,
AUTOSAR_SRS_General.pdf
- [4] Specification of ECU Configuration,
AUTOSAR_ECU_Configuration.pdf
- [5] Glossary
AUTOSAR_Glossary.pdf
- [6] Requirements on CAN
AUTOSAR_SRS_CAN.pdf
- [7] Specification of CAN Interface
AUTOSAR_SWS_CAN_Interface.pdf
- [8] API Specification of Development Error Tracer
AUTOSAR_SWS_DET.pdf
- [9] Specification of Function Inhibition Manager
AUTOSAR_SWS_FIM.pdf
- [10] Specification of PDU Router
AUTOSAR_SWS_PDU_Router.pdf

- [11] Specification of Diagnostic Event Manager (DEM)
AUTOSAR_SWS_DEM.pdf
- [12] AUTOSAR Basic Software Module Description Template,
AUTOSAR_BSW_Module_Description.pdf

3.2 Related standards and norms

- [13] ISO 15765-2 (2004-10-12), Road vehicles — Diagnostics on Controller Area Networks (CAN) — Part2: Network layer services
- [14] ISO 15765-3 (2004-10-06), Road vehicles — Diagnostics on Controller Area Networks (CAN) — Part3: Implementation of diagnostic services
- [15] ISO 15765-4 (2005-01-04), Road vehicles — Diagnostics on Controller Area Networks (CAN) — Part4: Requirements for emissions-related systems

4 Constraints and assumptions

4.1 Limitations

The AUTOSAR architecture defines communication system specific transport layers (CanTp, LinTp including LinIf, FlexRayTp). Thus the CAN Transport Layer only covers CAN transport protocol specifics.

The CAN Transport Layer has an interface to a single underlying CAN Interface Layer and a single upper PDU Router module.

According to the AUTOSAR release plan, this CAN Transport Layer specification has the following restriction:

- CAN Transport Layer runs only in an event triggered mode,
- No reception cancellation.

Furthermore, to significantly reduce resources and runtime this CAN Transport Layer implementation does not support full-duplex communication.

4.2 Applicability in automotive domain

The CAN Transport Layer can be used for all domains whenever the CAN communication system is connected to the appropriate ECU.

5 Dependencies on other modules

This section sets out relations between the CanTp and other AUTOSAR basic software modules. It contains short descriptions of some AUTOSAR basic concepts, configuration information and services, which are required by the CanTp from other modules.

5.1 AUTOSAR architecture basic concepts

5.1.1 CAN Transport Layer connection(s)

In the AUTOSAR architecture final release, transport protocol facilities will be used to transport both diagnostic (e.g. OBD and UDS protocols) and AUTOSAR COM I-PDUs¹. Therefore, the CanTp module is able to deal with multiple connections simultaneously (i.e. multiple segmentation sessions in parallel).

The maximum number of simultaneous connections is statically configured. This configuration has an important impact on complexity and resource consumption (CPU, ROM and RAM) of the code generated, because resources (e.g. Rx and Tx state machines, variables used to work on N-PCI data and so on) have to be reserved for each simultaneous access.

To allow the user to choose which I-PDUs could be received (or sent) simultaneously, each N-SDU identifier will be internally routed through a configured CanTp “connection channel”. Since a “connection channel” is not accessible externally, all necessary information (see chapter 10.2) to transfer an N-SDU will be linked to the N-SDU identifier (e.g. “connection channel” number, timeouts, addressing format, and so on).

5.1.2 CAN Transport Layer interactions

The figure below shows the interactions between CanTp, PduR and CanIf modules.

The CanTp's upper interface offers the PduR module global access, to transmit and receive data. This access is achieved by CAN N-SDU identifier (CAN NSdulId). CAN NSdulId refers to a constant data structure which consists of attributes describing CAN N-SDU. Each CAN N-SDU specific data structure may contain attributes such as: type of N-SDU (Tx or Rx), its addressing format, L-SDU identifier of this message or other attributes that are useful for implementation.

¹ Usage of CAN Transport Layer for AUTOSAR COM I-PDUs is planned for AUTOSAR Phase 2.

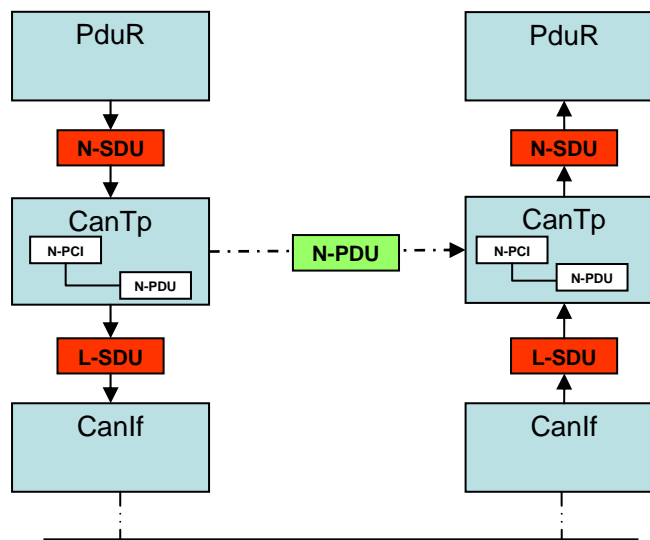

Figure 2: CAN Transport Layer interactions

5.1.3 Processing mode

The AUTOSAR communication stack supports both polling and event triggering mode. Therefore, each communication layer can receive information from its lower layer and propagate information to its upper layer by different mechanisms.

In the case of the CAN Transport Layer, only the event triggering mode is supported.

5.1.4 Data consistency

To optimize the communication stack, AUTOSAR limits the CAN Transport Layer buffering capacity. Therefore, the CanTp copies N-SDU payload directly from the upper layer (e.g. DCM or PDU Router – in the case of 1:1 TP routing) to the CAN driver and vice-versa. Thus to guarantee data consistency, the upper layer will observe the following rules:

- At transmission time, the N-SDU data payload will remain unchanged, from transmit request until transmit confirmation has been received
- At reception time, the N-SDU data access will be locked, from buffer allocation request until the reception indication or the next buffer allocation request has been received

5.1.5 Static configuration

At runtime the CAN Transport module must have all information required to manage transport connection. Therefore, the following properties should be statically configured:

- Number of CAN N-SDU
- Unique identifier of each CAN N-SDU
- Communication direction of each CAN N-SDU (Tx or Rx)
- Addressing type of each CAN N-SDU (physical or functional)

- Addressing format of each connection (standard or extended) and, in the case of extended addressing format, the N_TA value
- Associated CAN L-SDU identifier of each CAN N-SDU identifier and if necessary (multiple frame segmentation session) the CAN L-SDU identifier used to transmit the CAN FC N-PDU
- Minimum length of the N-SDU

The configuration of the CAN Transport Layer can be performed during compilation or post-build (See chapter 10).

5.1.6 PDU Router services

The CAN Transport Layer declares and requests certain callback functions to confirm transmission, confirm transmission cancellation and notify reception of a message from/to the PDU-Router, and request a buffer, to reassemble segmented frames:

- *PduR_CanTpRxIndication*
- *PduR_CanTpProvideRxBuffer*
- *PduR_CanTpProvideTxBuffer*
- *PduR_CanTpTxConfirmation*

For more information about these functions, refer to the PDU Router module specification [10].

5.1.7 CAN Interface services

The CAN Transport Layer uses the following services of the CAN Interface to transmit CAN N-PDUs:

- *CanIf_Transmit*

For more information about this function, refer to the CAN Interface module specification [7].

5.2 File structure

5.2.1 Code file structure

CanTp159: The code file structure will not be completely defined within this specification. At this point it should be noted, that the code-file structure should include the following files:

- *CanTp_Lcfg.c* – for parameters configurable at link time
- *CanTp_PBcfg.c* – for parameters, which are configurable post-build.

These files will contain all link time and post-build configurable parameters.

5.2.2 Header file structure

AUTOSAR specifies that an ECU can be created from modules provided as object code, source code (generated or not) and even mixed.

The decision to provide a module as object code or source code is based on a compromise between IP protection, test coverage, code efficiency and configurability at system generation time. Thus depending on the configurability requirements of the OEM, suppliers may deliver the CanTp module as object code, generated code or source code.

The header file structure defined in this section allows the separation of platform, compiler and implementation specific definitions and declarations from general definitions, as well as the separation of source code and configuration.

CanTp156: The CanTp module shall construct its include file structure as shown in Figure 3.

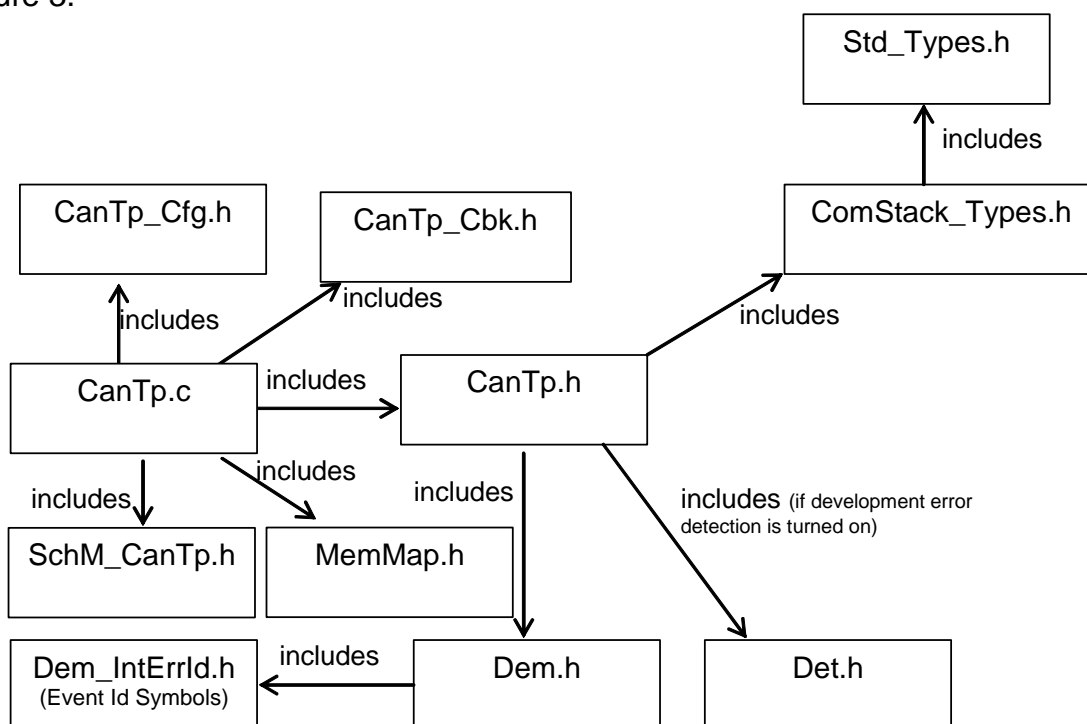

Figure 3: File Structure

Global data types and functions that are only used internally by the CAN Transport Protocol, are given in CanTp.c

CanTp219: CanTp.c shall include CanTp.h

CanTp157: The file CanTp.h shall only contain 'external' declarations of constants, global data, type definitions and services that are specified in the CAN Transport Protocol SWS.

CanTp001: CanTp_Cfg.h shall define constant and customizable data for module configuration at pre-compile time.

CanTp221: `CanTp.h` shall include `CanTp_Cfg.h`

CanTp165: BSW scheduler information is included via `SchM_CanTp.h`.

CanTp160: References to c-configuration parameters (link time and post-build time) will be placed in a separate h-file. The h-file should be the same as pre-compilation parameters.

CanTp024: Each header and C file of the CanTp module shall provide the possibility of version identification of the CAN Transport module by `CANTP_MAJOR_VERSION`, `CANTP_MINOR_VERSION` and `CANTP_PATCH_VERSION`.

Version number macros can then be used for checking and reading out the software version of a software module, during compile-time and run-time.

CanTp130: The module shall include the `Dem.h` file. By this inclusion the APIs to report errors as well as the required Event Id symbols are included. This specification defines the name of the Event Id symbols which are provided by XML to the DEM configuration tool. The DEM configuration tool assigns ECU dependent values to the Event Id symbols and publishes the symbols in `Dem_IntErrId.h`.

5.2.3 Design Rules

CanTp150: The CanTp module's source (as long as it is written in C) shall conform to the HIS subset of the MISRA C Standard.

CanTp151: The CanTp module's source shall not use compiler and platform specific keywords

CanTp152: The CanTp module's source shall indicate all global data with read-only properties by explicitly assigning the keyword `const`.

CanTp153: The CanTp module may use macros (instead of functions) where source code is used and runtime is critical.

CanTp155: The CanTp module shall not define global data in header files (If global variables have to be used, the definition should take place in the C file)

CanTp158: The CanTp module's source shall not be processor and compiler dependent.

6 Requirements traceability

Document: General Requirements on Basic Software Modules [3]

<i>Functional general requirements</i>	
Requirement	Satisfied by
[BSW00344] Reference to link-time configuration	Not applicable (This module does not use Link Time configuration parameters)
[BSW00404] Reference to post build time configuration	Not applicable (requirement on implementation, not on specification)
[BSW00405] Reference to multiple configuration sets	Not applicable (This module does not use multiple configuration sets)
[BSW00345] Pre-Build Configuration	CanTp001 chapter 10
[BSW159] Tool-based configuration	CanTp146
[BSW167] Static configuration checking	CanTp147
[BSW171] Configurability of optional functionality	chapter 10
[BSW170] Data for reconfiguration of SW-components	Not applicable. (Requirement on SWC module)
[BSW380] Separate C-File For configuration parameters	CanTp159
[BSW00419] Separate C-Files for pre-compile time configuration parameters	Not applicable (No "const" pre-compile time parameter)
[BSW381] Separate configuration header file for pre-compile time parameters	CanTp001
[BSW412] Separate H-File for configuration parameters	CanTp156
[BSW382] Not-used configuration elements need to be listed	Not applicable (there are no not-used configuration elements for this module)
[BSW383] List dependencies of configuration files	Not applicable (this module does not use configuration files from other modules)
[BSW384] List dependencies to other modules	Fulfilled by chapter 5
[BSW385] List possible error notifications	CanTp101
[BSW386] Configuration for detecting an error	CanTp101
[BSW387] Specify the configuration class of callback function	Fulfilled by chapter 8.4
[BSW388] Introduce containers	Fulfilled by configuration chapter 10
[BSW389] Containers shall have names	Fulfilled by configuration chapter 10
[BSW390] Parameter content shall be unique within the module	Fulfilled by configuration chapter 10
[BSW391] Parameter shall have unique names	Fulfilled by configuration chapter 10
[BSW392] Parameters shall have a type	Fulfilled by configuration chapter 10
[BSW393] Parameters shall have a range	Fulfilled by configuration chapter 10
[BSW394] Specify the scope of the parameters	Fulfilled by configuration chapter 10
[BSW395] List the required parameters (per parameter)	Fulfilled by configuration chapter 10
[BSW396] Configuration classes	Fulfilled by configuration chapter 10
[BSW397] Pre-compile-time parameters	Not applicable (definition)
[BSW398] Link-time parameters	Not applicable (definition)

[BSW399] Loadable Post-build time parameters	Not applicable (definition)
[BSW400] Selectable Post-build time parameters	Not applicable (definition)
[BSW402] Published information	CanTp140
[BSW00375] Notification of wake-up reason	Not applicable (this module does not provide any reason for wake-up)
[BSW101] Initialization interface	CanTp208
[BSW00416] Sequence of Initialization	Not applicable (requirement on system design, not on a single module)
[BSW406] Check module initialization	CanTp161
[BSW168] Diagnostic Interface of SW components	Not applicable (this module does not support a special diagnostic interface)
[BSW407] Function to read out published parameters	CanTp162 CanTp163
[BSW00423] Usage of SW-C template to describe BSW modules with AUTOSAR Interfaces	Not applicable. (This module has no interface with RTE)
[BSW00424] BSW main processing function task allocation	CanTp164
[BSW00425] Trigger conditions for schedulable objects	Not covered. New template needed
[BSW00426] Exclusive areas in BSW modules	Not covered. New template needed
[BSW00427] ISR description for BSW modules	Not applicable. (this module does not provide any ISRs)
[BSW00428] Execution order dependencies of main processing functions	Not applicable. (This module has only 1 MainFunction)
[BSW00429] Restricted BSW OS functionality access	Not applicable (this module doesn't use any OS objects or services)
[BSW00431] The BSW Scheduler module implements task bodies	Not applicable (requirement on the BSW scheduler module)
[BSW00432] Modules should have separate main processing functions for read/receive and write/transmit data path	Not applicable. (Mainfunction is used to manage time)
[BSW00433] Calling of main processing functions	Not applicable (requirement on the BSW scheduler module)
[BSW00434] The Schedule Module shall provide an API for exclusive areas	Not applicable (requirement on the BSW scheduler module)
[BSW00336] Shutdown interface	CanTp010
[BSW00337] Classification of errors	CanTp101
[BSW00338] Detection and Reporting of development errors	
[BSW00369] Do not return development error codes via API	CanTp021
[BSW00339] Reporting of production relevant errors and exceptions	CanTp008 CanTp100
[BSW00421] Reporting of production relevant error events	CanTp100
[BSW00422] Debouncing of production relevant error status	Not applicable. (DEM requirement)
[BSW00420] Production relevant error event rate detection	Not applicable. (DEM requirement)
[BSW00417] Reporting of Error Events by Non-Basic Software	Not applicable (This module is a BSW module)
[BSW00323] API parameter checking	CanTp132
[BSW004] Version check	CanTp024 CanTp140

[BSW00435] Header File Structure for the Basic Software Scheduler	CanTp156
[BSW00436] Module Header File Structure for the Basic Software Memory Mapping	CanTp156

Non-functional general requirements	
Software Architecture Requirements	
Requirement	Satisfied by
[BSW161] Microcontroller abstraction	Not applicable (requirement on AUTOSAR architecture, not a single module)
[BSW162] ECU layout abstraction	Not applicable (requirement on AUTOSAR architecture, not a single module)
[BSW00324] Do not use HIS Library	Not applicable (requirement on AUTOSAR architecture, not a single module)
[BSW005] No hard coded horizontal interfaces within MCAL	See paragraph 5.1.6 & 5.1.7
[BSW00415] User dependent include files	Not applicable (no interface for specifics)
[BSW166] BSW Module interfaces	See paragraph 5.2
Software Integration Requirements	
Requirement	Satisfied by
[BSW164] Implementation of interrupt service routines	Fulfilled by API definitions in chapter 8
[BSW00325] Runtime of interrupt service routines	Not applicable (this module does not provide any ISRs)
[BSW00326] Transition from ISRs to OS tasks	Not applicable (this module does not provide any ISRs)
[BSW00342] Usage of source code and object code	Not applicable (requirement on implementation, not on specification)
[BSW00343] Specification and configuration of time	Fulfilled by configuration chapter 10
[BSW160] Human-readable configuration data	Fulfilled by configuration chapter 10
Software Module Design Requirements	
Software quality	
Requirement	Satisfied by
[BSW007] HIS MISRA C	CanTp150
Naming conventions	
Requirement	Satisfied by
[BSW00300] Module naming convention	Fulfilled by API definitions in chapter 8
[BSW00413] Accessing instances of BSW modules	Not applicable. (Only 1 instance of CanTp allowed)
[BSW00347] Naming separation of different instances of BSW drivers	Not applicable. (For driver only.)
[BSW00347] Naming separation of drivers	Not applicable (For driver only.)
[BSW00305] Self-defined data types naming convention	Fulfilled by type definitions in chapter 8
[BSW00307] Global variables naming convention	Not applicable (no global variables are specified for this module)
[BSW00310] API naming convention	CanTp003
[BSW00373] Main processing function naming convention	CanTp164
[BSW00327] Error values naming convention	CanTp101

[BSW00335] Status values naming convention	Fulfilled by API definitions in chapter 8
[BSW00350] Development error detection keyword	CanTp006
[BSW00408] Configuration parameter naming convention	Fulfilled by configuration chapter 10
[BSW00410] Compiler switches shall have defined values	Fulfilled by configuration chapter 10
[BSW00411] Get version info keyword	Fulfilled by configuration chapter 10

Module file structure

Requirement	Satisfied by
[BSW00346] Basic set of module files	CanTp156
[BSW158] Separation of configuration from implementation	CanTp156 CanTp001
[BSW00314] Separation of interrupt frames and service routines	Not applicable (this module does not provide any ISRs)
[BSW00370] Separation of callback interface from API	CanTp156

Standard header files

Requirement	Satisfied by
[BSW00348] Standard type header	See Section 8.1
[BSW00353] Platform specific type header	CanTp002
[BSW00361] Compiler specific language extension header	Not applicable (requirement on implementation, not on specification)

Module Design

Requirement	Satisfied by
[BSW00301] Limit imported information	CanTp156
[BSW00302] Limit exported information	CanTp157
[BSW00328] Avoid duplication of code	Not applicable (requirement on implementation, not on specification)
[BSW00312] Shared code shall be reentrant	Fulfilled by API definitions in chapter 8
[BSW006] Platform independency	CanTp158

Types and keywords

Requirement	Satisfied by
[BSW00357] Standard API return type	Fulfilled by API definitions in chapter 8
[BSW00377] Module Specific API return type	Fulfilled by API definitions in chapter 8
[BSW00304] AUTOSAR integer data types	Fulfilled by API definitions in chapter 8
[BSW00355] Do not redefine AUTOSAR integer data types	Fulfilled by API definitions in chapter 8
[BSW00378] AUTOSAR Boolean type	Not applicable (Not used)
[BSW00306] Avoid direct use of compiler and platform specific keywords	CanTp151

Global data

Requirement	Satisfied by
[BSW00308] Definition of global data	CanTp155
[BSW00309] Global data with read-only constraint	CanTp152

Interface and API

Requirement	Satisfied by
[BSW00371] Do not pass function pointers via API	Fulfilled by API definitions in chapter 8
[BSW00358] Return type of init() functions	CanTp208
[BSW00414] Parameter of init function	CanTp208
[BSW00376] Return type and parameters of main processing functions	CanTp164
[BSW00359] Return type of callback functions	Fulfilled by API definitions in chapter 8
[BSW00360] Parameters of callback functions	Fulfilled by API definitions in chapter 8
[BSW00329] Avoidance of generic interfaces	Fulfilled by API definitions in chapter 8
[BSW00330] Usage of macros instead of functions	CanTp153
[BSW00331] Separation of error and status values	Chapter 7.1.1 and CanTp101

Software Documentation Requirements

Requirement	Satisfied by
[BSW009] Module User Documentation	Fulfilled by the whole document
[BSW00401] Documentation of multiple instances of configuration parameters	Fulfilled by configuration chapter 10
[BSW172] Compatibility and documentation of scheduling strategy	Not applicable. (There is no scheduler in the CAN TP)
[BSW010] Memory resource documentation	Not applicable. (requirement on implementation, not on specification)
[BSW00333] Documentation of callback function context	Fulfilled by API definitions in chapter 8
[BSW00374] Module vendor identification	CanTp140
[BSW00379] Module identification	CanTp140
[BSW003] Version identification	CanTp024 CanTp140
[BSW00318] Format of module version	
[BSW00321] Enumeration of module version numbers	Not applicable. (requirement on implementation, not on specification)
[BSW00341] Microcontroller compatibility documentation	Not applicable. (requirement on implementation, not on specification)
[BSW00334] Provision of XML file	Not applicable. (requirement on implementation, not on specification)

Document: AUTOSAR requirements on Basic Software, cluster CAN

Requirement	Satisfied by
[BSW01065] Usage of ISO 15765-2 specifications	CanTp033
[BSW01065] Usage of ISO 15765-4 specifications	See Section 7
[BSW01066] Concurrent connection configuration	CanTp096 CanTp120 CanTp121 CanTp122 CanTp123 CanTp124
[BSW01068] Unique identifier of N-SDU	CanTp035
[BSW01069] CAN address information and N-SDU identifier mapping	CanTp035
[BSW01071] Unique identifier of N-PDU	CanTp035
[BSW01073] Fixed N-PDU data length	CanTp040 CanTp098 CanTp116
[BSW01074] Transport connection properties	CanTp137 CanTp138
[BSW01075] CAN Transport Layer Initialization	CanTp170 , CanTp030
[BSW01076] CAN Transport Layer Availability	CanTp031
[BSW01078] Support a subset of ISO 15765-2 addressing modes formats	CanTp035 CanTp137 CanTp138
[BSW01079] Compliance with CAN Interface notifications	CanTp019 CanTp020
[BSW01081] Connection specific timeout values	CanTp137 CanTp138
[BSW01082] Error handling	CanTp057
[BSW01086] Data padding value of unused bytes	CanTp059
[BSW01111] CAN Transport Layer Interfaces	This requirement is a specification recommendation fulfilled by chapter 8
[BSW01112] Independent interface	This requirement is a specification recommendation fulfilled by chapter 8
[BSW01116] Usage of different addressing modes formats in parallel	CanTp137 CanTp138 CanTp139
[BSW01117] Only half-duplex communication is supported	CanTp057
[BSW01120] Multiple CAN Transport Layer instances	Multiple connections supported and therefore only one instance required.

7 Functional specification

This section provides a description of the CAN Transport Layer functionality. It explains the services provided to the upper and lower layers and the internal behavior of the CAN Transport Layer.

The CanTp module offers services for segmentation, transmission with flow control, and reassembly of messages. Its main purpose is to transmit and receive messages that may or may not fit into a single CAN frame. Messages that do not fit into a single CAN frame are segmented into multiple parts, such that each can be transmitted in a single CAN frame.

While reading this document, it is necessary to bear in mind, that this module will follow the recommendations ISO 15765-2 (OEM enhanced diagnostics [13]) and should be able to fulfill ISO 15765-4 (Requirements for emissions-related systems [15]).

CanTp033: If a recommendation of ISO 15765-2 is not explicitly excluded in the SWS, the CanTp module shall follow this recommendation.

For further descriptions of SF, FF, CF and FC frames, network layer timing parameters, and further functionalities of CAN Transport Layer please refer to the ISO 15765-2 specification [13].

ISO 15765-4 is a particular case of ISO-15765-2. Therefore, the CAN Transport Layer will be configurable, in order to be able to adapt the module to all ISO 15765-4 use cases (e.g. specific timing, padding configuration, addressing mode). See chapter 10, Configuration specification, for details.

7.1 Services provided to upper layer

The service interface of the CanTp module can be divided into the following main categories:

- Initialization and shutdown
- Communication services

The following paragraphs describe the functionality of each services category.

7.1.1 Initialization and shutdown

CanTp027: The CanTp module shall have two internal states, `CANTP_OFF` and `CANTP_ON`.

CanTp168: The CanTp module shall be in the `CANTP_OFF` state after power up.

CanTp169: In the state `CANTP_OFF`, the CanTp shall allow an update of the postbuild configuration.

CanTp170: The CanTp module shall change to the internal state `CANTP_ON` when the CanTp has been successfully initialized with `CanTp_Init()`.

CanTp238: The CanTp module shall performed segmentation and reassembly tasks only when the CanTp is in the `CANTP_ON` state.

CanTp030: The function `CanTp_Init` shall initialize all global variables of the module and sets all transport protocol connections in a sub-state of `CANTP_ON`, in which neither segmented transmission nor segmented reception are in progress (Rx thread in state `CANTP_RX_WAIT` and Tx thread in state `CANTP_TX_WAIT`).

The COM Manager module should call the function `CanTp_Init()` before using the CanTp functionalities.

CanTp031: If development error detection for the CanTp module is enabled: The CanTp module shall raise an error (`CANTP_E_UNINIT`) when the PDU Router or CAN Interface tries to use any function (except `CanTp_GetVersionInfo`) before the function `CanTp_Init` has been called.

CanTp111: If called when the CanTp module is in the global state `CANTP_ON`, the function `CanTp_Init` shall return the module to state `Idle` (state = `CANTP_ON`, but neither transmission nor reception are in progress) and the module shall loose all current connections .

CanTp010: The function `CanTp_Shutdown` shall stop the CanTp module properly.

The COM Manager module shall call the function `CanTp_Shutdown()` .

The following figure summarizes all of the above requirements:

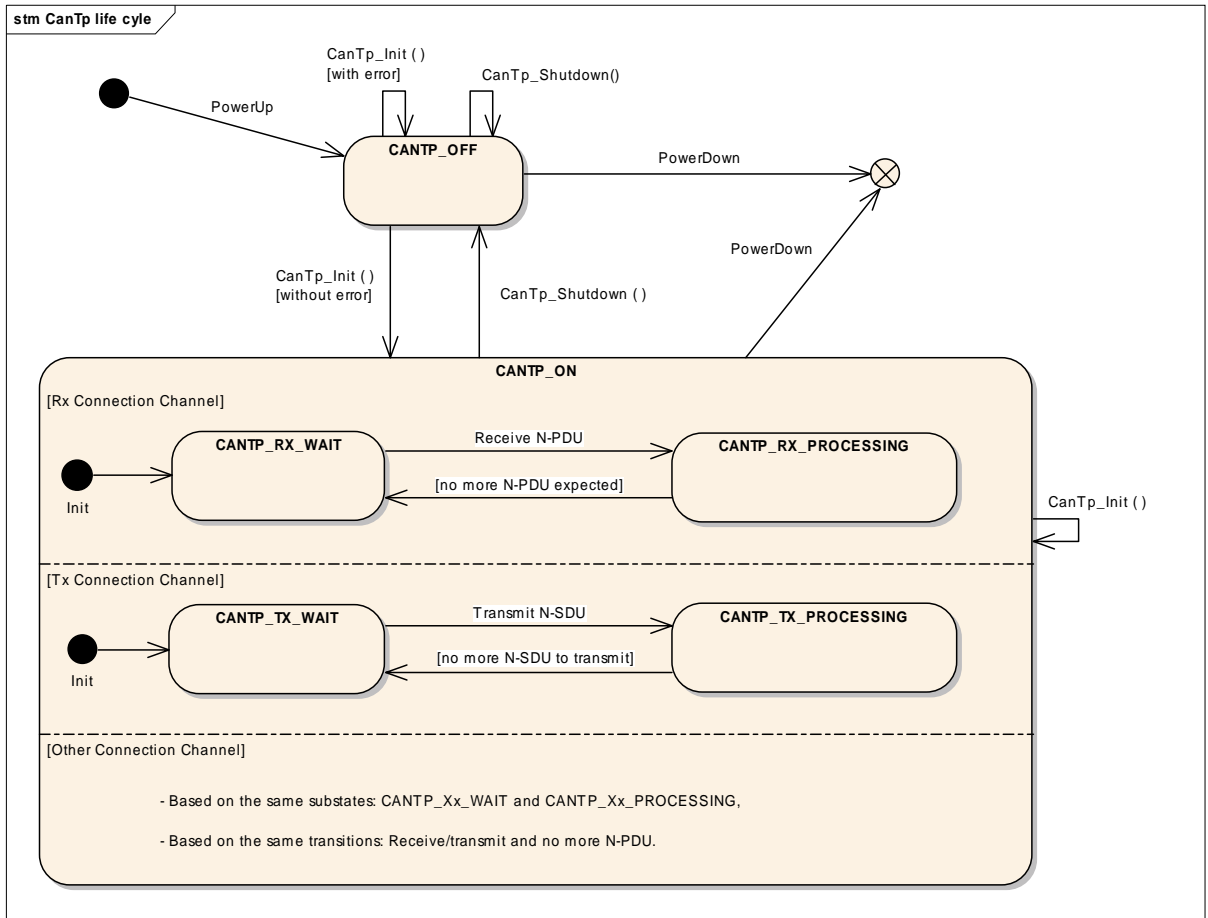

Figure 4: CAN Transport Layer life cycle

7.1.2 Transmit request

The transmit operation, `CanTp_Transmit()`, will allow upper layers to ask for data transfer using CAN transport protocol facilities (segmentation, extended addressing format and so on).

CanTp176: The function `CanTp_Transmit()` shall be asynchronous.

CanTp177: The `CanTp` module shall notify its upper layer if the N-SDU transfer is fully processed (successfully or not).

CanTp072: The function `CanTp_Transmit()` shall reject the transmit request and return the status value `E_NOT_OK` if there is no hardware resource available.

7.1.3 Transmit cancellation

The transmit cancellation feature allows the upper layer to cancel a transmission in progress.

Use case: Cancel a diagnostic transmission due to the reception of another diagnostic protocol with higher priority.

CanTp242: This feature shall be (de)activated by static configuration (parameter `CanTpTc`). Transmit Cancellation is triggered by the call of `CanTp_CancelTransmitRequest()`.

CanTp243: After the call of the service `CanTp_CancelTransmitRequest()`, the transfer on this connection shall be aborted

CanTp244: The Api `PduR_CanTpTxConfirmation()` shall be called after a transmit cancellation with value `NTFRSLT_E_CANCELATION_OK`

Note that if a transfer is in progress, that will generate a time-out error on the receiver side.

7.2 Services provided to the lower layer

According to the AUTOSAR specification of the communication stack, the CAN Transport Layer provides the following two callback functions to the Can interface: `CanTp_TxConfirmation()` and `CanTp_RxIndication()`.

7.2.1 Transmit confirmation

CanTp074: The `CanIf` module shall call the transmit confirmation function to notify the CAN Transport Layer that a CAN frame transmission, requested by the `CanTp`, has been performed successfully. The L-PDU identifier is associated with the call in order to identify the corresponding transmission.

CanTp075: If the transmit confirmation is not received after a maximum time (equal to `N_A`s), the `CanTp` module shall act as if it had received an unsuccessful transmission confirmation and any late confirmation shall be ignored. The `CanTp` module shall cancel (internally) the failed transmission.

CanTp076: For confirmation calls, the `CanTp` module shall provide the function `CanTp_TxConfirmation()`.

7.2.2 Reception indication

CanTp077: The `CanIf` module shall call the reception indication function to notify the `CanTp` module that a new CAN N-PDU frame (i.e. a transport protocol frame) has been received.

The reception indication can be performed in ISR context according to `CanIf` configuration.

CanTp078: For reception indication, the `CanTp` module shall provide `CanTp_RxIndication()`.

7.3 Internal behavior

The internal operation of the CAN Transport Layer provides basic mechanisms in order to perform the main purpose of this module, which is to transfer diagnostic messages in a single CAN frame or in multiple CAN frames.

The entire behavior of the CAN Transport Layer will be event triggered, so that CanTp can process transfer of N-SDU (respectively L-SDU) coming from the PDU Router (respectively CAN Interface) directly.

7.3.1 N-SDU Reception

To optimize communication stack resources, it has been decided to provide the CAN Transport Layer with limited buffering capacity.

CanTp079: When receiving an SF or an FF N-PDU, the CanTp module shall notify the upper layer (PDU Router) about this reception and request an Rx buffer to process the frame reassembly. These two operations shall be performed using the `PduR_CanTpProvideRxBuffer()` function.

CanTp166: At the reception of a FF or a SF, the CanTp module shall start a time-out `N_Br` before requesting a Rx buffer. If a buffer has not been provided before the timer elapsed, the CanTp module shall abort the communication.

CanTp080: The Rx buffer provided can be smaller than the expected N-SDU data length. In this case, when the current buffer has been filled up with data, the CanTp module shall request another buffer by calling the `PduR_CanTpProvideRxBuffer()` service again.

To avoid confusion, it should be clarified that the expression “request a buffer” is not related to dynamic memory allocation. This expression simply means the upper layer makes a buffer available to the CAN Transport Layer (i.e. the Rx buffer is locked until CanTp calls either `PduR_CanTpRxIndication()` or `PduR_CanTpProvideRxBuffer()`).

If the upper layer cannot provide a buffer because of an error (e.g. in the gateway case it may indicate that the transport session to the destination network has been broken) or a resource limitation (e.g. N-SDU length exceeds the maximum buffer size of the upper layer), the `PduR_CanTpProvideRxBuffer()` function returns `BUFREQ_E_NOT_OK` or `BUFREQ_E_OVFL`.

CanTp081: After the reception of a First Frame, if the function `PduR_CanTpProvideRxBuffer` returns `BUFREQ_E_NOT_OK` or `BUFREQ_E_OVFL` to the CanTp module, the CanTp module shall send a Flow Control N-PDU with overflow status (FC(OVFLW)) and abort the N-SDU reception. If the error occurs after a Consecutive Frame reception, the Flow Control frame shall not be sent

If the upper layer temporarily has no Rx buffer available, the `PduR_CanTpProvideRxBuffer()` function returns `BUFREQ_E_BUSY`.

CanTp082: If the function `PduR_CanTpProvideRxBuffer` returns `BUFREQ_E_BUSY` to the CanTp module, the CanTp module shall suspend the N-SDU reception by sending the next Flow Control N-PDU with status WAIT (i.e. FC(WT)).

CanTp222: Before expiration of the `N_Br` timer (ISO 15765-2 specification defines the following performance requirement: $(N_Br + N_Ar) < 0.9 * N_Bs$ timeout), the CanTp module shall call the service to provide an Rx buffer again during the next processing of the MainFunction. If the buffer request is delayed again, the CanTp module shall send a new FC(WAIT).

CanTp223: The CanTp module shall send a maximum of `WFTmax` consecutive FC(WAIT) N-PDU. If this number is reached, the CanTp module shall abort the reception of this N-SDU (the receiver did not send any FC N-PDU, so the `N_Bs` timer expires on the sender side and then the transmission is aborted) and a receiving indication with `NTFRSLT_E_NOT_OK` occurs.

CanTp224: When the Rx buffer is finally provided, the CanTp module shall send a Flow Control N-PDU with `ClearToSend` status (FC(CTS)) and shall carry on the reception of the Consecutive Frame N-PDUs.

CanTp084: When the transport reception session is completed (successfully or not) the CanTp module shall call the upper layer notification service `PduR_CanTpRxIndication()`.

With regard to FF N-PDU reception, the content of the Flow Control N-PDU depends on the `PduR_CanTpProvideRxBuffer()` service result.

CanTp064: Furthermore, it should be noted that when receiving a FF N-PDU, the Flow Control shall only be sent after having the result of the `PduR_CanTpProvideRxBuffer()` service.

It is important to note that FC N-PDU will only be sent after every block, composed of a number BS (Block Size) of consecutive frames.

CanTp067: If the Rx buffer provided is smaller than the entire N-SDU data length and its length is not a multiple of $BS * 7$ (or $BS * 6$ in case of extended addressing format), the CanTp module shall temporarily change the BS value to fill up the buffer reception completely. The desired behavior is described in the following picture

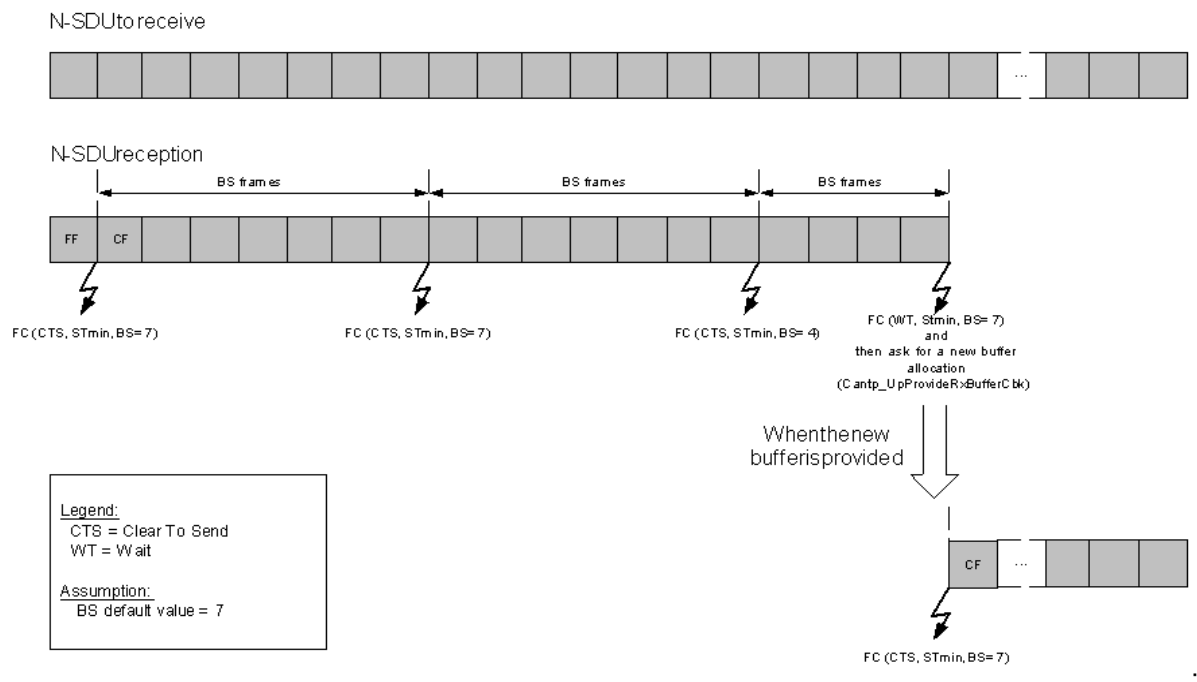

Figure 5: Management of the BS value

7.3.2 N-SDU Transmission

As described in chapter 7.1.2, the upper layer asks for the transmission of a N-SDU by calling `CanTp_Transmit()`. The parameters of `CanTp_Transmit()` describe the CAN NSduId and a reference to a `PduInfoType` that indicates the full Tx N-SDU length given.

CanTp225: The function `CanTp_Transmit` shall only use the `SduLength` information within the `PduInfoType` parameter and shall not use the pointer to the payload N-SDU data.

CanTp226: After a transmission request from the upper layer, the `CanTp` module shall call `PduR_CanTpProvideTxBuffer` at least once to request the necessary transmit buffer.

CanTp167: After a transmission request from upper layer, the `CanTp` module shall start time-out `N_Cs` before requesting a Tx buffer. If a buffer has not been provided before the timer elapsed, the `CanTp` module shall abort the communication.

The Tx buffer provided can be smaller than the full Tx N-SDU data length.

CanTp086: If the Tx buffer provided to the `CanTp` module is smaller than the full Tx N-SDU data length and when the entire content of this buffer has been sent, the `CanTp` module shall request another buffer by calling the function `PduR_CanTpProvideTxBuffer()` again.

CanTp117: If the data in the Tx buffer cannot be sent completely, the CanTp layer shall request a new buffer from the upper layer and shall buffer the remaining bytes that have not been sent yet.

If the upper layer cannot provide a Tx buffer because of an error (e.g. in the gateway case it may indicate that the transport session to the destination network has been broken), the `PduR_CanTpProvideTxBuffer()` function returns `BUFREQ_E_NOT_OK`.

CanTp087: If `PduR_CanTpProvideTxBuffer()` returns `BUFREQ_E_NOT_OK`, the CanTp module shall abort the transmit request and notify the upper layer of this failure by calling the callback function `PduR_CanTpTxConfirmation()` with the result `NTFRSLT_E_NOT_OK`.

If upper layer temporarily has no Tx buffer available, the `PduR_CanTpProvideTxBuffer()` function returns `BUFREQ_E_BUSY`.

CanTp184: If the `PduR_CanTpProvideTxBuffer()` function returns `BUFREQ_E_BUSY`, the CanTp module shall later (implementation specific) retry to receive a buffer.

CanTp185: If no buffer is provided before the expiration of the `N_Cs` timer (ISO 15765-2 specification defines the following performance requirement: $(N_Cs + N_As) < 0.9 * N_Cr$ timeout), the CanTp module shall abort this transmission session and notify the upper layer of this failure by calling the callback function `PduR_CanTpTxConfirmation` with the result `NTFRSLT_E_NOT_OK`.

The API `PduR_CanTpProvideTxBuffer()` contains a parameter `length` used for the recovery mechanism. Because ISO 15765-2 does not support such a mechanism, the CAN Transport Layer does not implement any kind of recovery. Thus, the `length` parameter is always set to zero (0) and upper layers can return a buffer of free length.

CanTp186: The CanTp module shall set the `length` parameter in the call to `PduR_CanTpProvideTxBuffer` to zero (0).

CanTp089: When the Tx buffer is provided, the CanTp module shall resume the transmission of the N-SDU.

CanTp090: When the transport transmission session is successfully completed, the CanTp module shall call a notification service of the upper layer, `PduR_CanTpTxConfirmation()`, with the result `NTFRSLT_OK`.

7.3.3 Buffer strategy

Because CanTp has limited buffering capability, the N-SDU payload, which is to be transmitted, is not copied internally and the N-PDU received is not reassembled internally.

The CAN Transport Layer works directly on the memory area of the upper layers (e.g. PduR, DCM, or COM). To access these memory areas, the CAN Transport Layer uses the indicator returned by the `PduR_CanTpProvideTxBuffer()` or `PduR_CanTpProvideRxBuffer()` functions.

Thus, to guarantee data consistency, the upper layer should lock this memory area until an indication occurs.

When a transmit buffer is locked, the upper layer must not write data inside the buffer area.

When a receiving buffer is locked the CAN Transport Layer does not guarantee data consistency of the buffer. The upper layer should neither read nor write data in the buffer area.

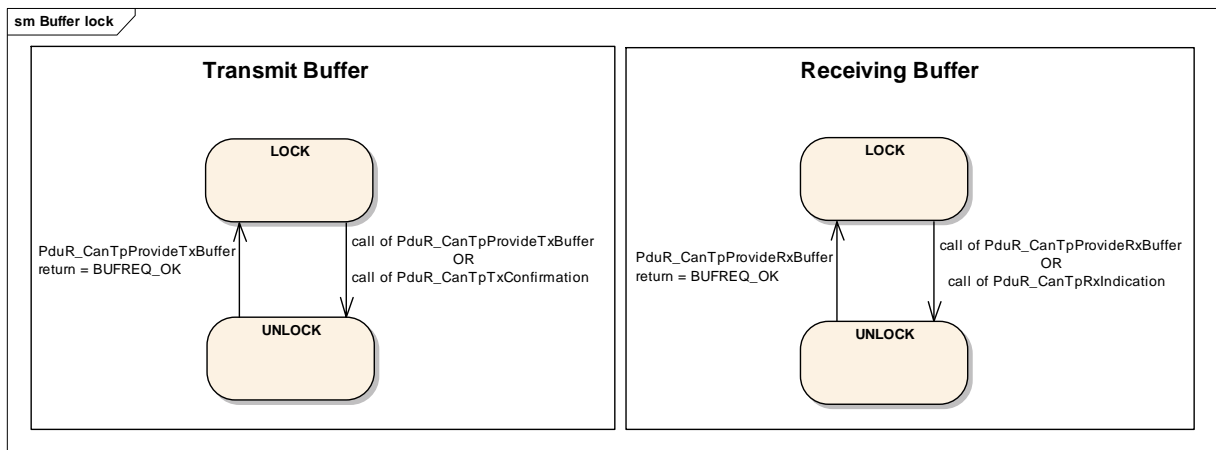

Figure 6: Tx and Rx Buffer locking

CanTp227: The PduR module shall lock the buffer when it returns a status `BUFREQ_OK` to a `PduR_CanTpProvideTxBuffer()` or `PduR_CanTpProvideRxBuffer()` call and shall keep the buffer locked until the CAN transport Layer requests a new buffer (`PduR_CanTpProvideTxBuffer()` or `PduR_CanTpProvideRxBuffer()` call) or when a confirmation or indication (`PduR_CanTpTxConfirmation()` or `PduR_CanTpRxIndication()` call) occurs.

The following figure provides an example, to summarize the process of sending a frame, with a length of 50 bytes and two sub-buffers of 25 bytes.

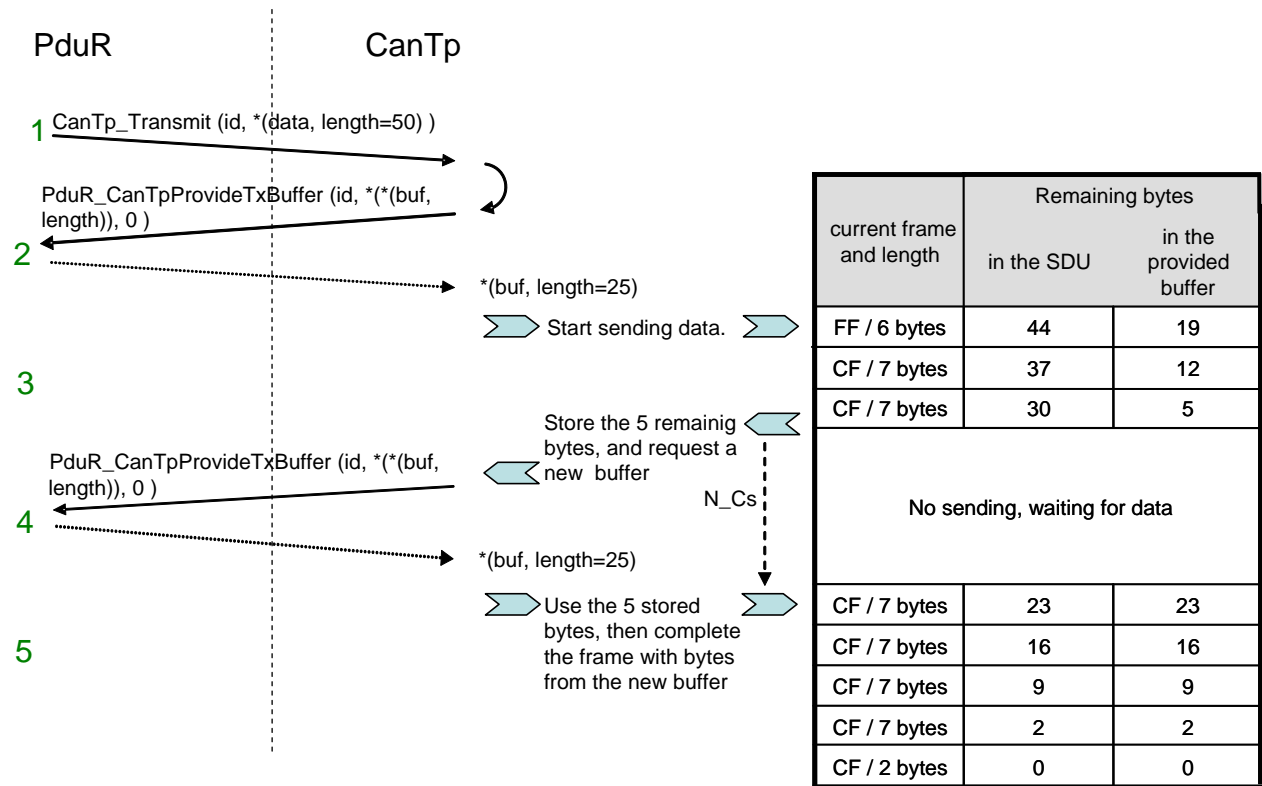

Figure 7: Example of transmit process

- 1:** The PduR asks for the transmission of 50 data bytes
- 2:** The CanTp asks the PduR for the data by requesting the buffer containing the payload data. The PduR provides a buffer of 25 bytes (by conception in this example, it is not able to provide a buffer of 50 bytes directly)
- 3:** The CanTp starts the transmission of the payload data. After the second consecutive frame transmission, there are still 5 data bytes available in the buffer. As a consecutive frame will contain 7 data bytes, the CanTp should request a new buffer from the PduR, in order to have enough data to send. Therefore, it should store the 5 data bytes available and afterwards request the buffer.
- 4:** The CanTp asks the PduR for the data, by requesting the buffer containing the next payload data. The PduR provides a buffer of 25 bytes
- 5:** The CanTp continues the transmission of the payload data.

This figure shows the necessity for CAN Transport Layer to use a local buffer to store some data before requesting a new buffer.

The new buffer should be provided before the N-Cs timer expires. To extend this timing constraint, the CAN Transport Layer could use a larger internal buffer and request the next buffer (`PduR_CanTpProvideTxBuffer()`) before the current buffer is empty (or not sufficient to transmit a complete consecutive frame).

The next figure is an example of an N-SDU receiving 49 bytes, with two buffers of 25 bytes provided.

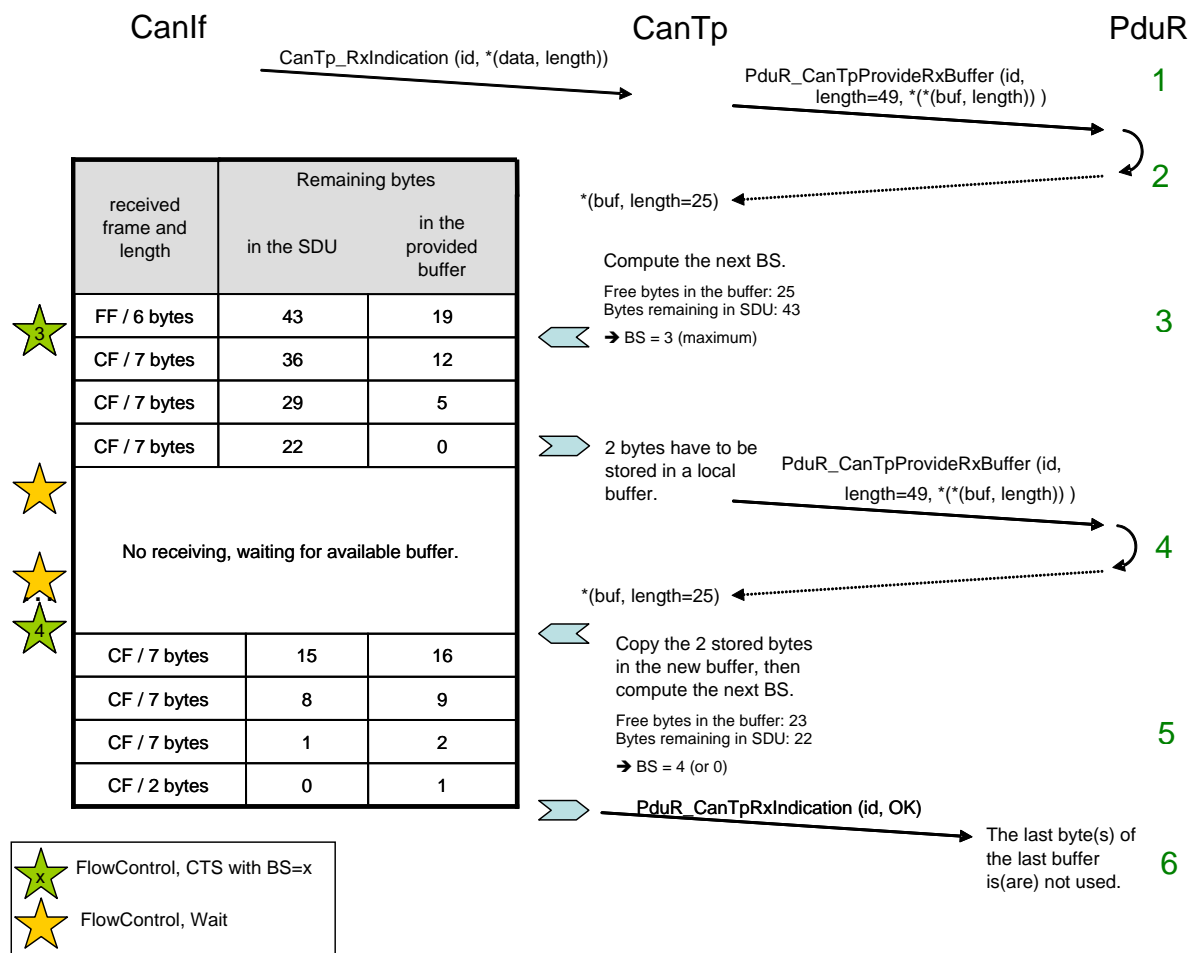

Figure 8: Example of receiving process

- 1:** The CanIf notifies a new reception with CanTp_RxIndication(). The CanTp asks the PduR for a buffer in order to store the received data.
 - 2:** The PduR provides a buffer of 25 bytes (by conception in this example, it is not able to provide a buffer of 49 bytes directly)
 - 3:** The CanTp manages the payload data reception until the buffer is full (on the third consecutive frame). On this third consecutive frame the CAN Transport Protocol can only store 5 bytes in the buffer. Therefore, it should request a new buffer and temporarily store the remaining 2 bytes in a local buffer.
 - 4:** The CanTp asks the PduR for a new buffer in order to store the data received subsequently.
 - 5:** The CanTp copies the 2 bytes, temporarily stored in local buffer, to the buffer provided by the PduR and manages the payload data reception until the end of reception.
 - 6:** The CanTp informs the PduR of the end of reception by a call to PduR_CanTpRxIndication().
- The CAN Transport Layer will compute the BS values (See [CanTp067](#)) depending on:
- maximum configured value for this N-SDU,

- number of free bytes inside the buffer provided,
- amount of receiving bytes.

When the last buffer is returned to the upper layer (PduR_CanTpRxIndication()), the last bytes (in the example just the last byte) could be unused.

The upper layer shall take care identify these unused bytes with the knowledge of the total N-SDU length (function parameter of PduR_CanTpProvideRxBuffer()).

Another solution to avoid unused bytes is for the upper layer to provide the last buffer with the exact length, which should be received.

If the BS value is equal to 0 the buffer should be sized to a value equal or larger than the number of bytes to be received.

7.3.4 No Protocol parameter setting services

CanTp091: The CanTp module shall not support optional primitives (proposed in ISO 15765-2 specification) for the dynamic setting of some transport protocol internal parameters (STmin and BS) by application. Thus, STmin and BS values shall only be set statically N-SDU by N-SDU.

The configured BS value is only a maximum value. For reasons of buffer length, the CAN Transport Layer can adapt the BS value within the limit of the configured maximum value.

7.3.5 Tx and Rx data flow

The following figures show examples of an un-segmented message transmission and a segmented one.

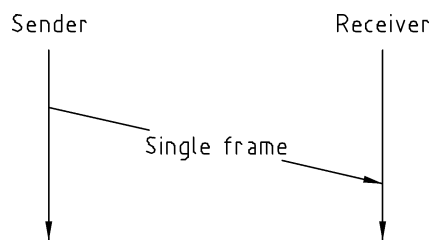

Figure 9: Example of single part message

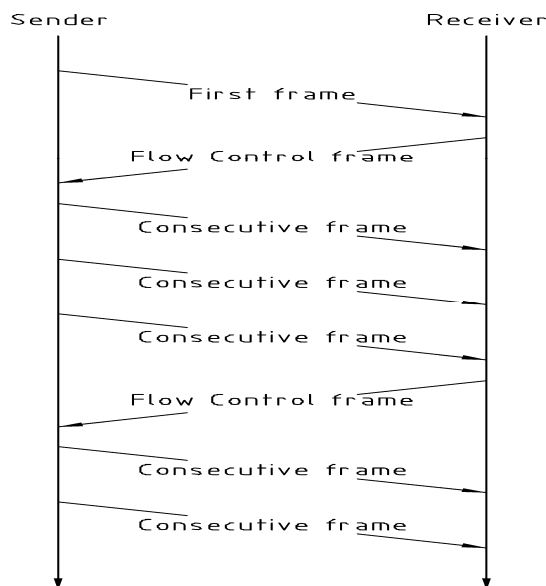

Figure 10: Example of multiple parts message

Flow control is used to adjust the sender to the capabilities of the receiver. The main usage of this transport protocol is peer-to-peer communication (i.e. 1 to 1 communication – physical addressing [13]).

CanTp092: The CanTp module shall provide 1 to n communication (i.e. functional addressing [13]), in the form of functionality to SF N-PDUs (and only SF N-SDU).

The configuration tool shall check whether it is only SF N-PDUs that have been configured with a functional addressing property.

CanTp093: If a multiple segmented session occurs (on both receiver and sender side) with a handle whose communication type is functional, the CanTp module shall reject the request and generate, if the development error detection is enabled, a development error CANTP_E_PARAM_CONFIG.

7.3.6 Relationship between CAN NSduld and CAN LSduld

This chapter describes the connection that exists between CAN NSduld and CAN LSduld, in order to make transmission and reception of transport protocol data units possible.

CanTp035: A CAN NSduld shall only be linked to one CAN LSduld that is used to transmit SF, FF, FC and CF frames.

However, if the message is configured to use an extended addressing format, the CanTp module must fill the first byte of each transmitted segment (SF, FF and CF) with the N_TA value. Therefore a CAN NSduld may also be related to a N_TA value.

FC protocol data units give receivers the possibility of controlling senders' data flow by authorizing or delaying transmission of subsequent CF N-PDUs. For extended addressing format, the first data byte of the FC also contains the N_TA value.

CanTp094: Thus the CAN LSduld of a FC frame combined with its N_TA value (e.g. the N_AI) shall only identify one CAN NSduld.

In the reception direction, the first data byte value of each (SF, FF or CF) transport protocol data unit will be used to determine the relevant N-SDU.

CanTp095: Therefore, in extended addressing N-PDU reception, the CanTp module shall extract the N-TA value to establish the related N-SDU.

The following figure summarizes these discussions.

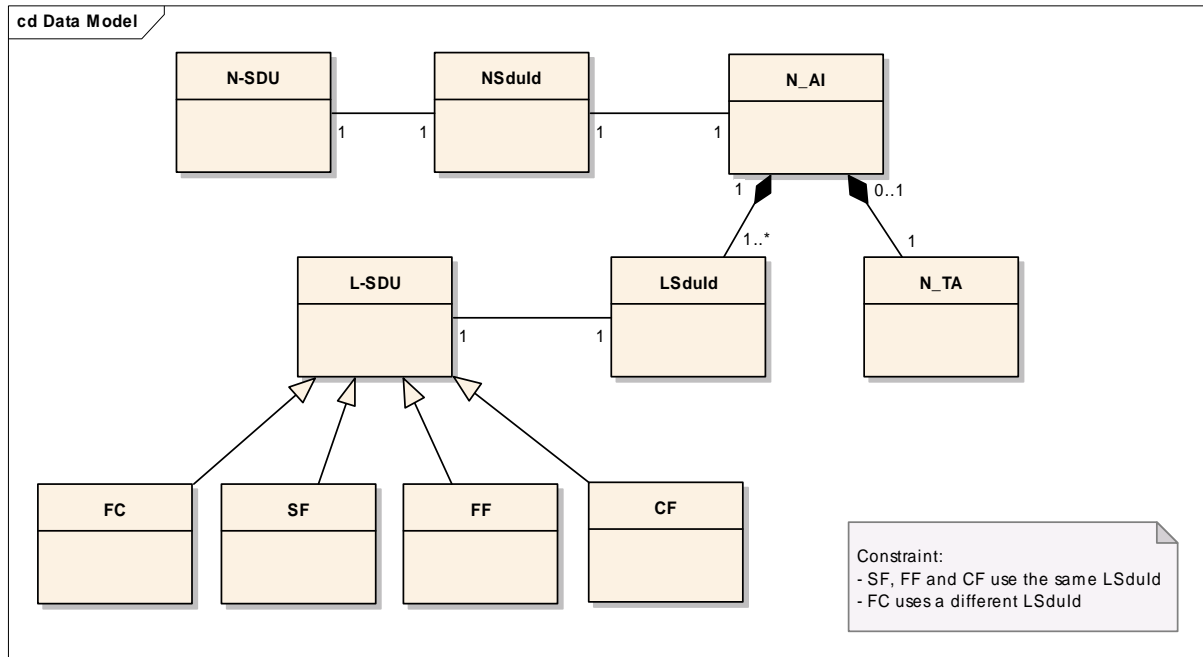

Figure 11: Possible links between NSduld and LSduld

7.3.7 Concurrent connection

In this second release document, the CAN Transport Layer will only be used for diagnosis communication (i.e. the CanTp is used to transfer DCM I-PDU). However, the CAN Transport Layer is able to manage several connections simultaneously (e.g. a UDS and an OBD request can be received at the same time).

CanTp096: The CanTp module shall support several connections simultaneously

CanTp120: It shall be possible to configure concurrent connections in the CanTp module. The connection channels are only destined for CAN TP internal use, so they are not accessible externally. All the necessary information (Channel number, Timing parameter ...) is configured inside the CAN Transport Layer module.

CanTp121: Each N-SDU is statically linked to one connection channel. This connection channel represents an internal path, for the transmission or receiving of the N-SDU. A connection channel is attached to one or more N-SDU.

CanTp122: Each connection channel is independent of the other connection channels. This means that a connection channel uses its own resources, such as internal buffer, timer, or state machine.

CanTp190: The CanTp module shall route the N-SDU through the correctly configured connection channel.

Note that this mechanism does not allow for the receiving or the transmission of N-SDU with the same identifier in parallel, because each N-SDU is linked to only one connection channel.

If a user wants to dedicate a specific connection channel to only one N-SDU, they should assign this connection channel to one N-SDU only during the configuration process.

If a connection channel is assigned to multiple N-SDUs, then resources are shared between different N-SDUs, and the CAN Transport Layer will reject transmission or abort receiving, if no free connection channels are available.

The number of connection channels is not directly configurable. It will be determined by the configuration tools during the configuration process, by analyzing the N-SDU/Channel routing table.

CanTp123: If the configured transmit connection channel is in use (state `CANTP_TX_PROCESSING`), the CanTp module shall reject new transmission requests linked to this channel. To reject a transmission, CanTp returns `E_NOT_OK` when the upper layer asks for a transmission with the `CanTp_Transmit()` function.

CanTp124: If the configured receiving connection channel is in use (state `CANTP_RX_PROCESSING`), on reception of new data (First Frame reception) the CanTp module shall abort the reception in progress and shall process the received frame as the start of a new reception.

CanTp248: A Tx N-PDU Id shall not be used on two or more different connection channels. An Rx N-PDU Id can only be used on two or more different connection channels if extended addressing is used in relation with this N-PDU Id.

7.3.8 N-PDU padding

To guarantee complete compatibility with all upper layer requirements concerning the frame data length (e.g. OBD requires data length to always be set to 8 bytes, however UDS does not), the padding activation is configurable at pre-compile time.

CanTp114: The CanTp module shall allow configuration of the padding activation at pre-compile time, by using parameter `CanTpRxPaddingActivation`.

CanTp040: If the `CanTpRxPaddingActivation` parameter is set to `ON`, the CanTp module shall only transfer N-PDU with a length of eight bytes (i.e. `DLC = 8`) between the CanTp and the CanIf. Thus, a received N-PDU shorter than 8 bytes will be considered corrupt by CanTp

CanTp098: If the `CanTpRxPaddingActivation` parameter is set to `OFF`, the CanTp module shall check the frame data length. If a frame is received with an unexpected datalength (check only for too short DLCs), the frame shall be ignored.

CanTp116: In both padding and no padding modes, the CanTp module shall only transfer used data bytes to the upper layer.

CanTp059 To improve transfer time, the CanTp module shall send unused byte(s) without any initialization.

7.3.9 Handling of unexpected N-PDU arrival

The behavior of the CAN Transport Layer on unexpected N-PDU arrival is greatly dependent on the communication direction type of the processing N-SDU.

CanTp057: If unexpected frames are received, the CanTp module shall behave according to the table below.

This table considers the actual CanTp internal status (CanTp status) and the requirement to not support full-duplex communication. It must be understood, that the received N-PDU contains the same address information (N_AI) as the reception or transmission, which may be in progress at the time the N_PDU is received.

<i>CanTp</i>	<i>Reception of</i>					
	status	SF N-PDU	FF N-PDU	CF N-PDU	FC N-PDU	Unknown N-PDU
Segmented Transmit in progress	Ignore	Ignore	Ignore	Ignore	If awaited, process the FC N-PDU, otherwise ignore it.	Ignore
Segmented Receive in progress	Terminate the current reception, report an indication, with parameter Result set to NTFRSLT_E_NOT_OK, to the upper layer, and process the SF N-PDU as the start of a new reception	Terminate the current reception, report an indication, with parameter Result set to NTFRSLT_E_NOT_OK, to the upper layer, and process the FF N-PDU as the start of a new reception	Process the CF N-PDU in the ongoing reception and perform the required checks (e.g. SN in right order)	Ignore	Ignore	Ignore
Idle ²	Process the SF N-PDU as the start of a new reception	Process the FF N-PDU as the start of a new reception	Ignore	Ignore	Ignore	Ignore

Table 1: Handling of unexpected N-PDU arrivals

7.4 Error classification

This section describes how the CanTp module has to manage the several error classes that may occur during the life cycle of this basic software.

The general requirements document of AUTOSAR [3] specifies that all basic software modules must distinguish (according to the product life cycle) two error types:

- Development errors: these errors should be detected and fixed during development phase. In most cases, these errors are software errors. The detection errors that should only occur during development can be switched off for production code (by static configuration, namely preprocessor switches).
- Production errors: these errors are hardware errors and software exceptions that cannot be avoided and are expected to occur in the production (i.e. series) code.

² Idle = CANTP_ON.CANTP_RX_WAIT and CANTP_ON.CANTP_TX_WAIT

CanTp008: On errors and exceptions, the CanTp module shall not modify its current module state (see Figure 4: CAN Transport Layer life cycle) but shall simply report the error event.

In case of production error, the Diagnostic Event Manager module (via the Function Inhibition Manager) will perform the appropriate action (e.g. status modification of the calling module).

CanTp192: Values for production code Event Ids are assigned externally by the configuration of the Dem. They are published in the file Dem_IntErrId.h and included via Dem.h.

CanTp101: Development error values are of type uint8.

<i>Type or error</i>	<i>Relevance</i>	<i>Related error code</i>	<i>Value [hex]</i>
API service called with wrong parameter(s) : When CanTp_Transmit is called for a none configured TX I-Pdu On any Null-Pointer given on API calls	Development	Could be a combination of: CANTP_E_PARAM_CONFIG CANTP_E_PARAM_ID CANTP_E_PARAM_ADDRESS	0x01 0x02 0x04
API service used without module initialization : On any API call except CanTp_Init() and CanTp_GetVersionInfo() if CanTp is in state CANTP_OFF"	Development	CANTP_E_UNINIT	0x20
Invalid Transmit PDU identifier (e.g. a service is called with an inexistent Tx PDU identifier)	Development	CANTP_E_INVALID_TX_ID	0x30
Invalid Receive PDU identifier (e.g. a service is called with an inexistent Rx PDU identifier)	Development	CANTP_E_INVALID_RX_ID	0x40
Invalid Transmit buffer address (e.g. the Tx buffer address is inaccessible or NULL)	Development	CANTP_E_INVALID_TX_BUFFER	0x50
Invalid Receive buffer address (e.g. the Rx buffer address is inaccessible or NULL)	Development	CANTP_E_INVALID_RX_BUFFER	0x60
Invalid data length of the transmit PDU (e.g. a transmit N-SDU has a length equal to zero)	Development	CANTP_E_INVALID_TX_LENGTH	0x70
Invalid data length of the receive PDU (e.g. a receive FF N-PDU has a FF_DL equal to zero)	Development	CANTP_E_INVALID_RX_LENGTH	0x80
CanTp_Transmit() is called	Development	CANTP_E_INVALID_TATYPE	0x90

for a configured Tx I-Pdu with functional addressing and the length parameter indicates, that the message can not be sent with a SF			
Requested operation is not supported	Production	CANTP_E_OPER_NOT_SUPPORTED	Assigned by DEM
Another error occurred during a reception or a transmission	Production	CANTP_E_COMM	Assigned by DEM

7.5 Error detection

CanTp006: The detection of development errors is configurable (*ON / OFF*) at pre-compile time.

The switch *CanTpDevErrorDetect* (see chapter 10) should activate or deactivate the detection of all development errors.

CanTp132: If the *CanTpDevErrorDetect* switch is enabled API parameter checking is enabled. The detailed description of the detected errors can be found in chapter 7.4 and chapter 8.

CanTp133: The detection of production code errors cannot be switched off.

CanTp161: A static status variable, denoting whether a BSW module is initialized, should be initialized with value 0 before any APIs of the BSW module are called.

The initialization function of the BSW modules will set the static status variable to a value not equal to 0.

This variable is used to check if the module has been initialized before calling an API.

7.6 Error notification

CanTp134: Detected development errors will be reported to the error hook of the Development Error Tracer (DET) if the pre-processor switch *CanTpDevErrorDetect* is set.

CanTp193: Production errors shall be reported to Diagnostic Event Manager.

The Development Error Tracer module is merely an aid to BSW development and integration. The API is defined, but the functionality can be chosen and implemented according to the development needs (e.g. error count, send error information via a serial interface to an external logger, and so on).

CanTp021: The CanTp module shall use the Development Error Tracer service [8]:

```
void Det_ReportError(ModuleId, InstanceId, ApiId, ErrorId) to report development errors.
```

CanTp115: The header file of the CanTp module, `CanTp.h`, shall provide a module ID, called `CANTP_MODULE_ID` sets, to the value `0x23`.

The following figure describes how this function can be used when the Development Error Tracer is on.

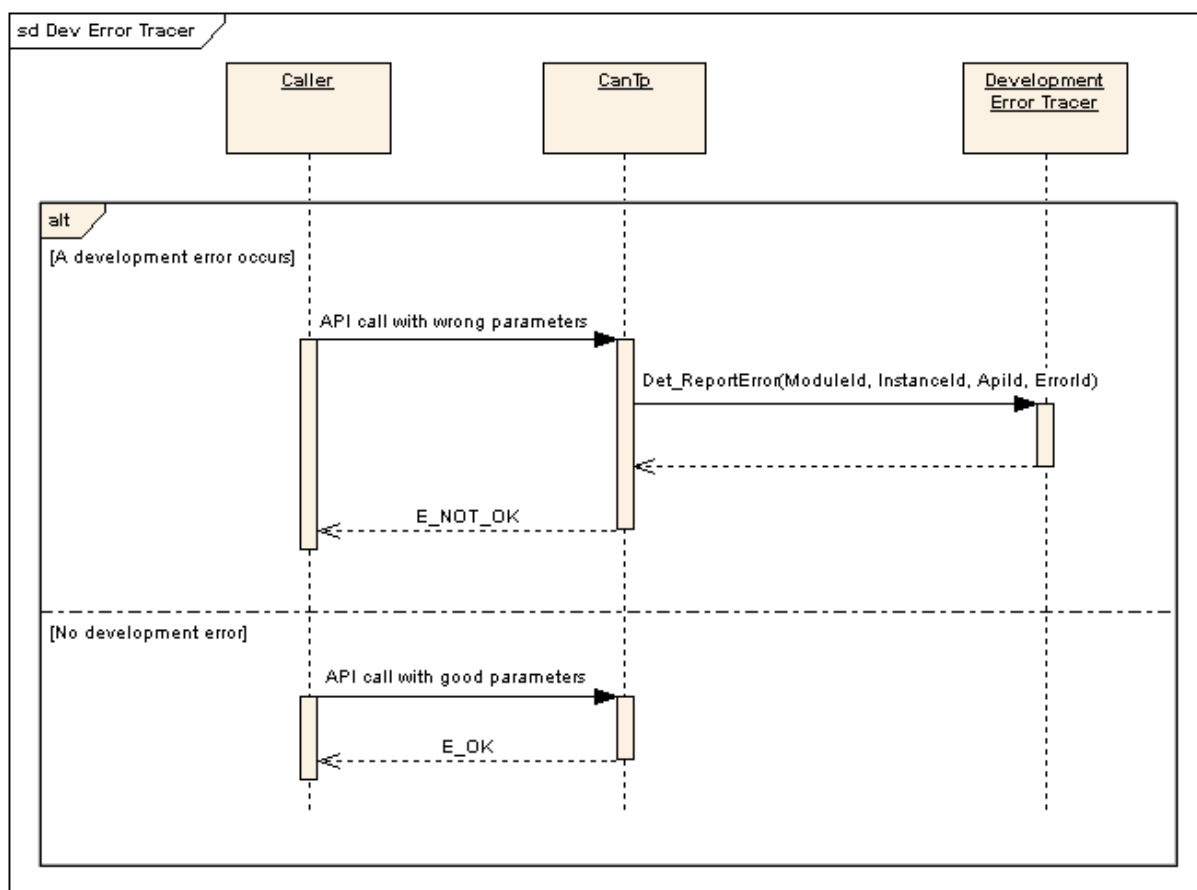

Figure 12: Development error reporting

As shown in the above figure, when a development error occurs the CanTp returns the value `E_NOT_OK`. The error description is only reported via the API of the Development Error Tracer module.

CanTp100: The CanTP module shall use the API services of the DEM module software specification [11] to report production errors.

This DEM module dumps the error into the “error memory” and informs the FIM module, which has a pre-defined reaction for the ECU (e.g. disabling ECU functions, switching ECU mode, etc).

CanTp229: If the task was aborted (e.g. As, Bs, Cs, Ar, Br, Cr timeout), the CanTp module shall call the DEM with `EventId= CANTP_E_COM` `EventStatus=DEM_EVENT_STATUS_PREFAILED`.

CanTp230: The DEM shall use a debounce algorithm of type *Counter based* for CanTp errors.

8 API specification

8.1 Imported types

In this chapter all types included from the following files are listed:

CanTp209:

Header file	Imported Type
Dem_Types.h	Dem_EventIdType
BufReq_Types.h	BufReq_ReturnType
LinIf_Types.h	PduInfoType
PrimitiveTypes.h	PduInfoType
Std_Types.h	Std_ReturnType
	Std_VersionInfoType
FrTp_Types.h	NotifResultType
ComStack_Types.h	PduIdType
	PduLengthType

In order to receive a consistent API for the AUTOSAR communication stack, basic types have been defined. These types are used by the CAN Transport Layer to communicate with the Pdu-Router and with the CAN Interface Layer.

For more information, these basic types are presented in depth in the AUTOSAR COM stack API specification.

These AUTOSAR standard types will be used without any type redefinition.

CanTp002: If, for implementation reasons, some additional types have to be defined, the CanTp module shall label these types as follows: CanTp_<TypeName>Type, where <TypeName> is the name of this type adhering to the rules:

- No underscore usage
- First letter of each word upper case, consecutive letters lower case.

The CanTp module shall ensure that implementation-specific types are not "visible" outside of CanTp. Otherwise, the complete architecture would be corrupted.

8.2 Type definitions

8.2.1 CanTp_CancelReasonType

Name:	CanTp_CancelReasonType	
Type:	Enumeration	
Range:	CANTP_CNLD0	Cancel Transfer because data are outdated
	CANTP_CNLNB	Cancel Transfer because no further buffer can be provided
	CANTP_CNLOR	Cancel Transfer because of another reason
Description:	The reason is sent to the other peer (not on receiver side in a 1:n connection) by the means of an appropriate FC frame.	

8.3 Function definitions

This is a list of functions provided for upper layer modules

CanTp003: The following provides the API Naming convention for the CanTp services:

- The service name format is CanTp_<ServiceName>(...)
- <ServiceName>: is the name of the service primitive with first letter of each word upper case and consecutive letters lower case

8.3.1 CanTp_Init

CanTp208:

Service name:	CanTp_Init
Syntax:	void CanTp_Init()
Service ID[hex]:	0x01
Sync/Async:	Synchronous
Reentrancy:	Non Reentrant
Parameters (in):	None
Parameters (inout):	None
Parameters (out):	None
Return value:	None
Description:	This function initializes the CanTp module.

After power up, CanTp is in a state called CANTP_OFF (see [CanTp168](#)). In this state, the CanTp is not yet configured and therefore cannot perform any communication task.

The function CanTp_Init initializes all global variables of the CAN Transport Layer with the given configuration set and set it in the idle state (state = CANTP_ON but neither transmission nor reception are in progress) (see [CanTp170](#) and [CanTp030](#)).

The function CanTp_Init has no return value because configuration data errors should be detected during configuration time (e.g. by the configuration tools). Furthermore, if a hardware error occurs, it will be reported via the error manager modules.

CanTp199: The CanTp module's environment shall call CanTp_Init before using the CanTp module for further processing.

8.3.2 CanTp_GetVersionInfo

CanTp210:

Service name:	CanTp_GetVersionInfo
Syntax:	void CanTp_GetVersionInfo(Std_VersionInfoType* versioninfo

)
Service ID[hex]:	0x07
Sync/Async:	Synchronous
Reentrancy:	Non Reentrant
Parameters (in):	None
Parameters (inout):	None
Parameters (out):	versioninfo Indicator as to where to store the version information of this module.
Return value:	None
Description:	This function returns the version information of the CanTp module.

CanTp162: The function CanTp_GetVersionInfo shall return the version information of this module. The version information includes:

- Module Id
- Vendor Id
- Vendor specific version numbers (BSW00407).
-

CanTp163: The function CanTp_GetVersionInfo shall be pre compile time configurable (On/Off) by the configuration parameter:

CANTP_VERSION_INFO_API.

CanTp218: If source code for caller and callee of CanTp_GetVersionInfo is available, the CanTp module should realize CanTp_GetVersionInfo as a macro, defined in the module's header file.

Note that the function CanTp_GetVersionInfo can be called before initialization of the CanTp module.

8.3.3 CanTp_Shutdown

CanTp211:

Service name:	CanTp_Shutdown
Syntax:	void CanTp_Shutdown()
Service ID[hex]:	0x02
Sync/Async:	Synchronous
Reentrancy:	Non Reentrant
Parameters (in):	None
Parameters (inout):	None
Parameters (out):	None
Return value:	None
Description:	This function to shutdown the CanTp module.

CanTp202: The function CanTp_Shutdown shall close all pending transport protocol connections, free all resources and set the CanTp module into the CANTP_OFF state.

CanTp200: The function CanTp_Shutdown shall not raise a notification about the pending frame transmission or reception.

8.3.4 CanTp_Transmit

CanTp212:

Service name:	CanTp_Transmit	
Syntax:	<pre>Std_ReturnType CanTp_Transmit(PduIdType CanTpTxSduId, const PduInfoType* CanTpTxInfoPtr)</pre>	
Service ID[hex]:	0x03	
Sync/Async:	Synchronous	
Reentrancy:	Reentrant	
Parameters (in):	CanTpTxSduId	This parameter contains the unique CanTp module identifier of the CAN N-SDU to be transmitted. Range: 0..(maximum number of L-PDU IDs received) - 1
	CanTpTxInfoPtr	An indicator of a structure with CAN N-SDU related data: indicator of a CAN N-SDU buffer and the length of this buffer.
Parameters (inout):	None	
Parameters (out):	None	
Return value:	Std_ReturnType	E_OK: The request can be started successfully E_NOT_OK: The request cannot be started (e.g. a transmit request is in progress with the same N-SDU identifier)
Description:	This service is used to request the transfer of segmented data.	

CanTp231: If data length is less than 7 or 6 (depending on normal or extended addressing format), the function `CanTp_Transmit` shall send a SF N-PDU.

CanTp232: If data length is greater than 7 or 6 (depending on normal or extended addressing format), the function `CanTp_Transmit` shall initiate a multiple frame transmission session.

CanTp204: The `CanTp` module shall notify the upper layer by calling the `PduR_CanTpTxConfirmation` callback when the transmit request has been completed.

CanTp205: The `CanTp` module shall abort the transmit request and call the `PduR_CanTpTxConfirmation` callback function with the appropriate error result value if an error occurred (over flow, `N_A`s timeout, `N_B`s timeout and so on).

CanTp206: The function `CanTp_Transmit` shall reject a request if the `CanTp_Transmit` service is called for a N-SDU identifier which is being used in a currently running CAN Transport Layer session.

Because `CanTp` has limited buffering capability, the N-SDU payload to be transmitted is not copied internally. The CAN Transport Layer works on the memory area referenced by the CAN N-SDU pointer obtained within the `CanTpProvideTxBuffer` service.

Thus, to guarantee the data consistency, the upper layer (e.g. DCM, `PduRouter` or AUTOSAR COM) must lock this memory area until the confirmation notification occurs.

When the upper layer calls this function, only the data length information of the structure indicated by `CanTpTxInfoPtr` has to be used. Its value indicates the payload length of the N-SDU, which is to be transmitted.

To access a Tx buffer, the CAN Transport Layer should call the `PduR_CanTpProvideTxBuffer` service.

8.3.4.1 `CanTp_CancelTransmitRequest`

CanTp246:

Service name:	<code>CanTp_CancelTransmitRequest</code>	
Syntax:	<pre>Std_ReturnType CanTp_CancelTransmitRequest(PduIdType CanTpTxPduId, CanTp_CancelReasonType CanTpCancelReason)</pre>	
Service ID[hex]:	0x03	
Sync/Async:	Asynchronous	
Reentrancy:	Reentrant	
Parameters (in):	<code>CanTpTxPduId</code>	This parameter contains the CAN TP instance unique identifier of the CAN N-SDU which transfer has to be cancelled.

	CanTpCancelReason	The reason for cancellation
Parameters (inout):	None	
Parameters (out):	None	
Return value:	Std_ReturnType	E_OK: Cancellation request of the transfer (sending or receiving) of the specified CAN N-SDU is accepted. E_NOT_OK: Cancellation request of the transfer of the specified CAN N-SDU is rejected, e. g. cancellation is requested at the receiver in an 1:n connection or in an unsegmented transfer at the receiver or cancellation is not allowed for the corresponding channel.
Description:	<p>This service primitive is used to cancel the transfer of pending CAN N-SDUs. The connection is identified by CanTpTxPduId.</p> <p>This function has to be called with the PDU-Id of the CanTp, i. e. the upper layer has to translate its own PDU-Id into the one of the TP for the corresponding message.</p>	

8.3.5 Main Function

CanTp213:

Service name:	CanTp_MainFunction
Syntax:	void CanTp_MainFunction()
Service ID[hex]:	0x06
Sync/Async:	Synchronous
Reentrancy:	Non Reentrant
Parameters (in):	None
Parameters (inout):	None
Parameters (out):	None
Return value:	None
Description:	The main function for scheduling the CAN TP.

CanTp164: The main function for scheduling the CAN TP (Entry point for scheduling)
The main function will be called by the Schedule Manager or by the Free Running Timer module according of the call period needed.

The function CanTp_MainFunction is affected by configuration parameter CanTpMainFunctionPeriod.

8.4 Call-back notifications

The following is a list of functions provided for lower layer modules.

CanTp233: The CanTp module shall provide the function prototypes of the callback functions in the file `CanTp_Cbk.h`

8.4.1 CanTp_RxIndication

CanTp214:

Service name:	CanTp_RxIndication	
Syntax:	<pre>void CanTp_RxIndication(PduIdType CanTpRxPduId, const PduInfoType* CanTpRxPduPtr)</pre>	
Service ID[hex]:	0x04	
Sync/Async:	Synchronous	
Reentrancy:	Reentrant	
Parameters (in):	CanTpRxPduId	ID of CAN L-PDU that has been received. Identifies the data that has been received. Range: 0..(maximum number of L-PDU IDs received) - 1
	CanTpRxPduPtr	Indicator of structure with received L-SDU (payload) and data length
Parameters (inout):	None	
Parameters (out):	None	
Return value:	None	
Description:	This function is called by the CAN Interface after a successful reception of a Rx CAN L-PDU.	

CanTp019: The CanIf module shall call this function after a successful reception of a Rx CAN L-PDU.

The data will be copied by the CanTp via the PDU structure `PduInfoType`. In this case the L-PDU buffers are not global and are therefore distributed in the corresponding CAN Transport Layer.

CanTp235: The function `CanTp_RxIndication` shall be callable in interrupt context (it could be called from the CAN receive interrupt).

CanTp234: The function `CanTp_RxIndication` shall be implemented using a pre-compile macro

8.4.2 CanTp_TxConfirmation

CanTp215:

Service name:	CanTp_TxConfirmation	
Syntax:	<pre>void CanTp_TxConfirmation(PduIdType CanTpTxPduId)</pre>	
Service ID[hex]:	0x05	
Sync/Async:	Synchronous	

Reentrancy:	Reentrant	
Parameters (in):	CanTpTxPduld	ID of CAN L-PDU that has been transmitted. Range: 0..(maximum number of L-PDU IDs received) - 1
Parameters (inout):	None	
Parameters (out):	None	
Return value:	None	
Description:	All transmitted CAN frames belonging to the CAN Transport Layer will be confirmed by this function.	

CanTp020: The CanIf module shall call the function CanTp_TxConfirmation after the TP related CAN Frame (SF, FF, CF, FC) has been transmitted through the CAN network.

CanTp236: The function CanTp_TxConfirmation shall be callable in interrupt context (it could be called from the CAN transmit interrupt).

CanTp237: The function CanTp_TxConfirmation shall be implemented using a pre-compile macro

8.5 Expected Interfaces

In this chapter, all interfaces required from other modules are listed.

8.5.1 Mandatory Interfaces

This chapter defines all interfaces, which are required, in order to fulfill the core functionality of the module.

CanTp216:

API function	Description
PduR_CanTpProvideRxBuffer	Provides Rx buffer for the CAN TP.
PduR_CanTpProvideTxBuffer	Provides Tx buffer for the CAN TP.
PduR_CanTpRxIndication	Rx indicator for the CAN TP
PduR_CanTpTxConfirmation	Tx confirmation for the CAN TP
CanIf_Transmit	--
Dem_ReportErrorStatus	Reports errors to the DEM.

8.5.2 Optional Interfaces

This chapter defines the interface, which is required, in order to fulfill the optional functionality of the module.

CanTp217:

API function	Description
Det_ReportError	Service to report development errors.

9 Sequence diagrams

The goal of this chapter is to make it easier to understand the CAN Transport Layer by describing most of the more frequent and complicated use cases. Thus, the following diagram sequences are not exhaustive and do not reflect all the specified API possibilities.

9.1 SF N-SDU received and no buffer provided

9.1.1 Assumptions

- All input parameters are OK
- The N-SDU data length is smaller than or equal to 7 bytes (6 bytes in the case of extended addressing format)
- Upper layer can not provide an Rx buffer

9.1.2 Sequence diagram

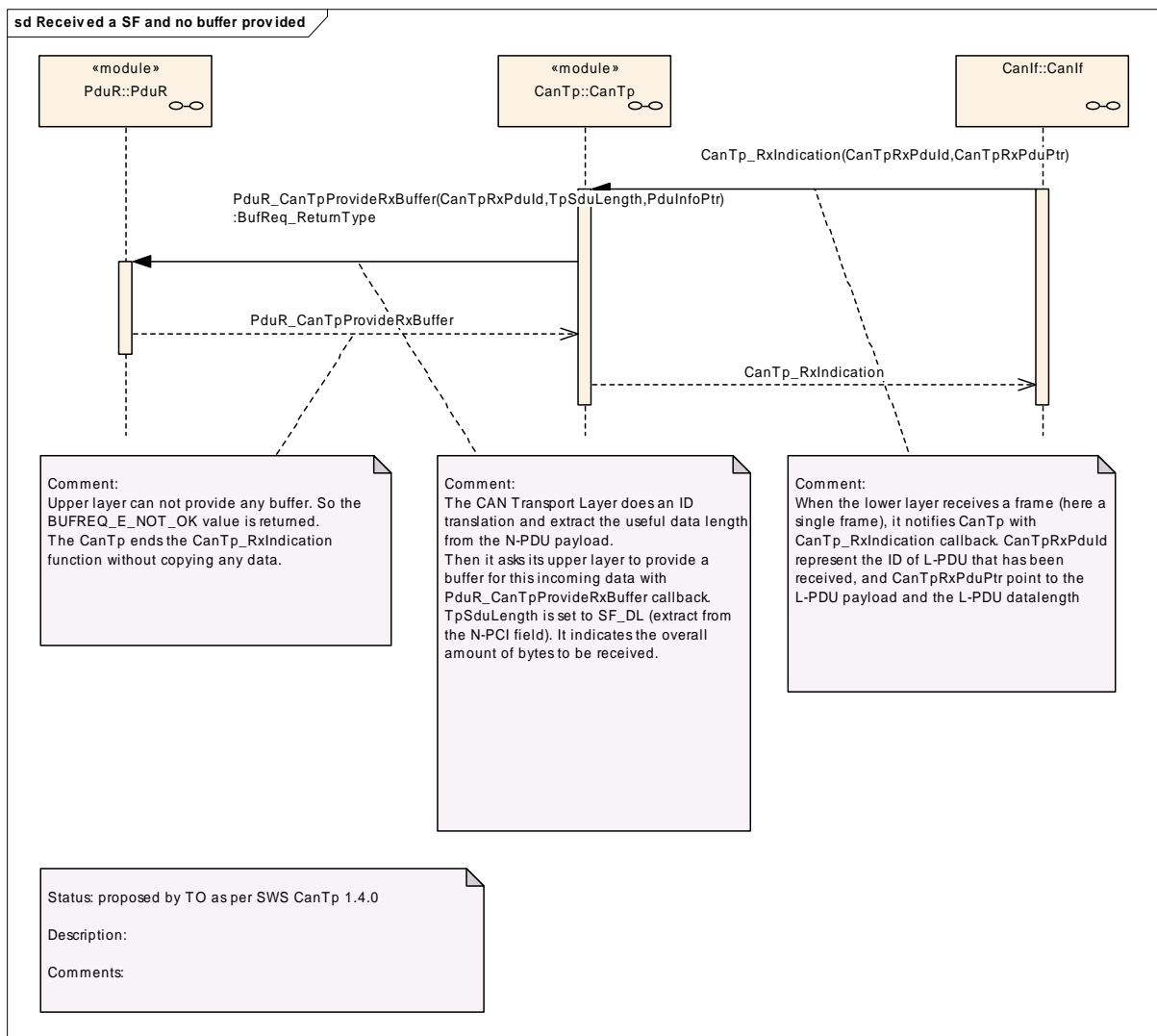

Note: This sequence diagram demonstrates the working of the CAN_Tp module only. However, if the whole system is considered during such reception, more modules are involved. Since this reception can be triggered in the context of CAN ISR, the CAN_Tp operation should be as short as possible.

9.1.3 Transition description

Transition	Name	Description
1	<pre>CanTp_RxIndication (CanTpRxPduId, CanTpRxPduPtr)</pre>	When the lower layer receives a frame (here a single frame), it notifies CanTp by means of a CanTp_RxIndication callback. CanTpRxPduId represents the ID of L-PDU that has been received, and CanTpRxPduPtr indicates the L-PDU payload and the L-PDU datalength
2	<pre>PduR_CanTpProvideRx Buffer(CanTpRxSduId, TpSduLength, PduInfoPtr)</pre>	<p>The CAN Transport Layer performs an ID translation and extracts the useful data length from the N-PDU payload. It then asks its upper layer to provide a buffer for this incoming data with a PduR_CanTpProvideRxBuffer callback.</p> <p>TpSduLength is set to SF_DL (extracted from the N-PCI field). It indicates the overall amount of bytes to be received.</p>
3	BUFREQ_E_NOT_OK	<p>The upper layer cannot provide any buffer, so the BUFREQ_E_NOT_OK value is returned.</p> <p>The CanTp ends the CanTp_RxIndication function without copying any data.</p>

9.2 Successful SF N-PDU reception

9.2.1 Assumptions

- All input parameters are OK
- The N-SDU data length is smaller than or equal to 7 bytes (6 bytes in the case of extended addressing format)
- The SF N-PDU is successfully received

9.2.2 Sequence diagram

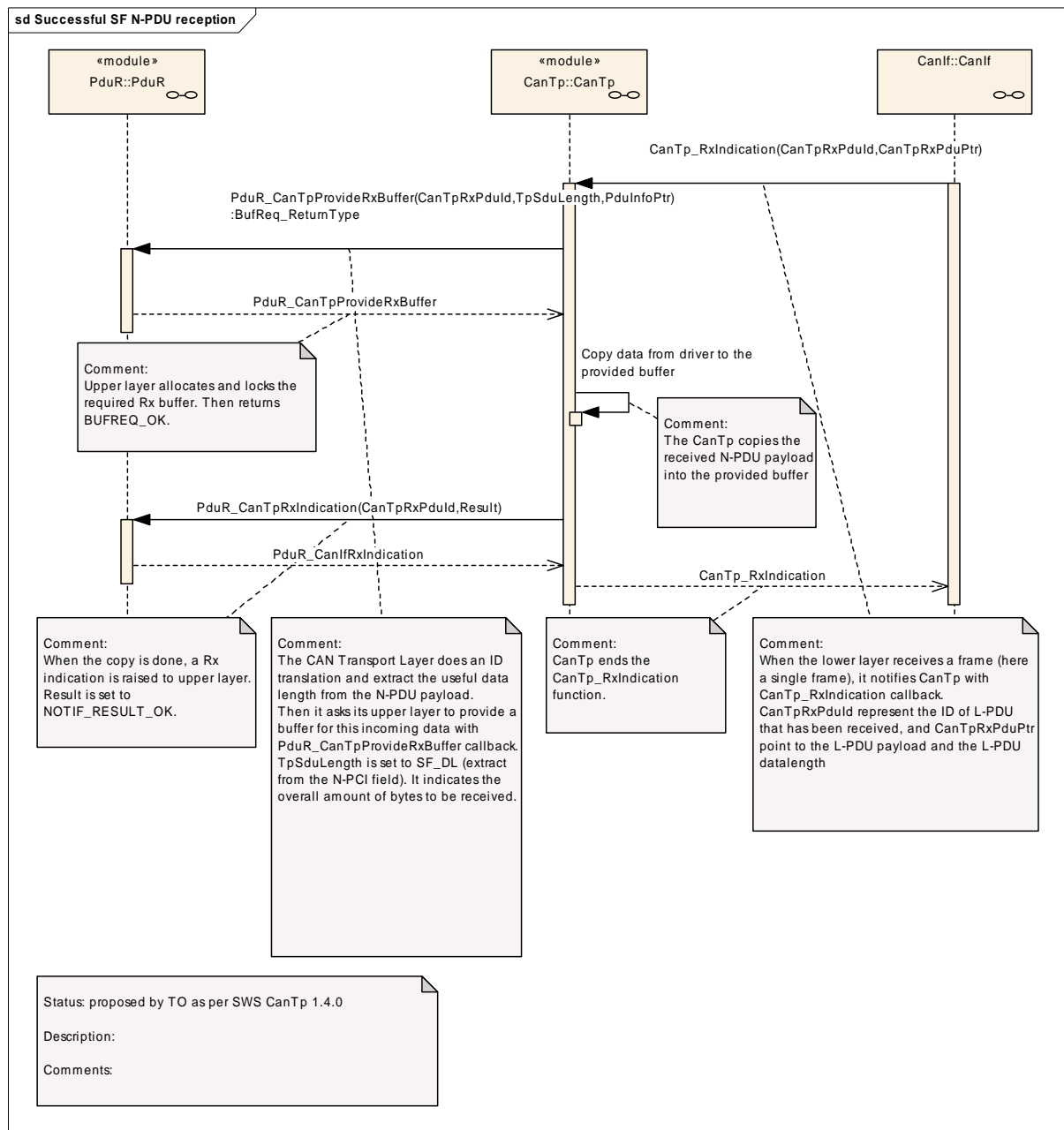

Note: This sequence diagram demonstrates the working of the CAN_Tp module only. However, if the whole system is considered during such reception, more modules are

involved. Since this reception can be triggered in the context of CAN ISR, the CAN_Tp operation should be as short as possible.

9.2.3 Transition description

Transition	Name	Description
1	CanTp_RxIndication (CanTpRxPduId, CanTpRxPduPtr)	When the lower layer receives a frame (here a single frame), it notifies CanTp by means of a CanTp_RxIndication callback. CanTpRxPduId represents the ID of the L-PDU that has been received, and CanTpRxPduPtr indicates the L-PDU payload and the L-PDU data length.
2	PduR_CanTpProvideRx Buffer (CanTpRxSduId, TpSduLength, PduInfoPtr)	The CAN Transport Layer performs an ID translation and extract the useful data length from the N-PDU payload. Then it asks its upper layer to provide a buffer for this incoming data with a PduR_CanTpProvideRxBuffer callback. TpSduLength is set to SF_DL (extracted from the N-PCI field). It indicates the overall amount of bytes to be received.
3	BUFREQ_OK	Upper layer allocates and locks the required Rx buffer. Then returns BUFREQ_E_OK.
4		The CanTp copies the received N-PDU payload into the buffer provided.
5	PduR_CanTpRxIndication (CanTpRxSduId, Result)	When the copy is complete, an Rx indication is sent to the upper layer. The result is set to NTFRSLT_OK.
6		CanTp ends the CanTp_RxIndication function.

9.3 Transmit request of SF N-SDU

9.3.1 Assumptions

- All input parameters are OK
- The N-SDU data length is smaller than or equal to 7 bytes (6 bytes in case of extended addressing format)
- The transmission is successfully processed

9.3.2 Sequence diagram

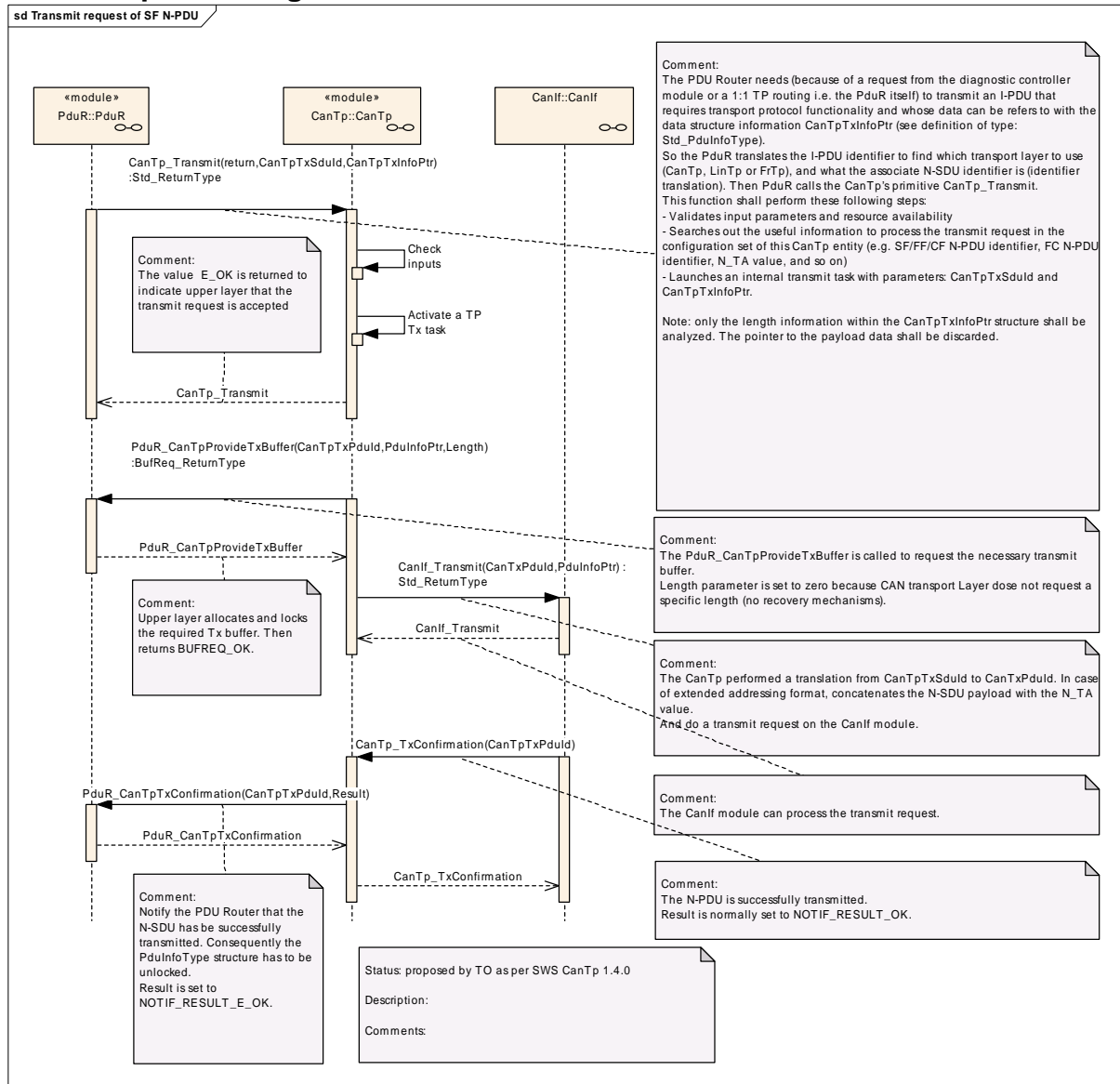

9.3.3 Transition description

Transition	Name	Description
1	<pre>CanTp_Transmit(CanTpTxSduId, CanTpTxInfoPtr)</pre>	<p>The PDU Router needs (because of a request from the diagnostic controller module or a 1:1 TP routing – i.e. the PduR itself) to transmit an I-PDU that requires transport protocol functionality and whose data can be referred to with the data structure information <code>CanTpTxInfoPtr</code> (see definition of type: <code>Std_PduInfoType</code>).</p> <p>Thus, the PduR translates the I-PDU identifier to establish which transport layer to use (<code>CanTp</code>, <code>LinTp</code> or <code>FrTp</code>), and what the associate N-SDU identifier is (identifier translation). Then PduR calls the <code>CanTp</code>'s primitive <code>CanTp_Transmit</code>.</p> <p>This function will perform the following steps:</p> <ul style="list-style-type: none"> - Validates input parameters and resource availability - Searches for the useful information to process the transmit request in the configuration set of this <code>CanTp</code> entity (e.g. SF/FF/CF N-PDU identifier, FC N-PDU identifier, <code>N_TA</code> value, and so on) - Launches an internal transmit task with the parameters: <code>CanTpTxSduId</code> and <code>CanTpTxInfoPtr</code>. <p>Note: only information concerning length, within the <code>CanTpTxInfoPtr</code> structure, will be analyzed. The payload indicator data should be discarded.</p>
2	E_OK	The value E_OK is returned to indicate to the upper layer that the transmit request is accepted
3	<pre>PduR_CanTpProvideTxBuffer (CanTpTxSduId, PduInfoPtr, Length=0)</pre>	<p>The <code>PduR_CanTpProvideTxBuffer</code> is called upon to request the necessary transmit buffer. Length parameter is set to zero because the CAN transport Layer does not request a specific length (no recovery mechanism).</p>
4	BUFREQ_OK	Upper layer allocates and locks the required Tx buffer, then returns <code>BUFREQ_E_OK</code> .
5	<pre>CanIf_Transmit(CanTxPduId, PduInfoPtr)</pre>	The <code>CanTp</code> performs a translation from <code>CanTpTxSduId</code> to <code>CanTxPduId</code> . In case of extended addressing format, it concatenates the N-SDU payload with the <code>N_TA</code> value, to perform a transmit request on the <code>CanIf</code> module.
6	E_OK	The <code>CanIf</code> module can process the transmit request.
7	<pre>CanTp_TxConfirmation(CanTpTxPduId,)</pre>	The N-PDU is successfully transmitted.
8	<pre>PduR_CanTpTxConfirmation (CanTpTxSduId, Result)</pre>	Notifies the PDU Router that the N-SDU has been successfully transmitted. Consequently, the <code>PduInfoType</code> structure has to be unlocked. Result is set to <code>NTFRSLT_OK</code> .

9.4 Transmit request of larger N-SDU

9.4.1 Assumptions

- All input parameters are OK
- The N-SDU data length is larger than 7 bytes (6 bytes in case of extended addressing format)
- The transmission is successfully processed

9.4.2 Sequence diagram

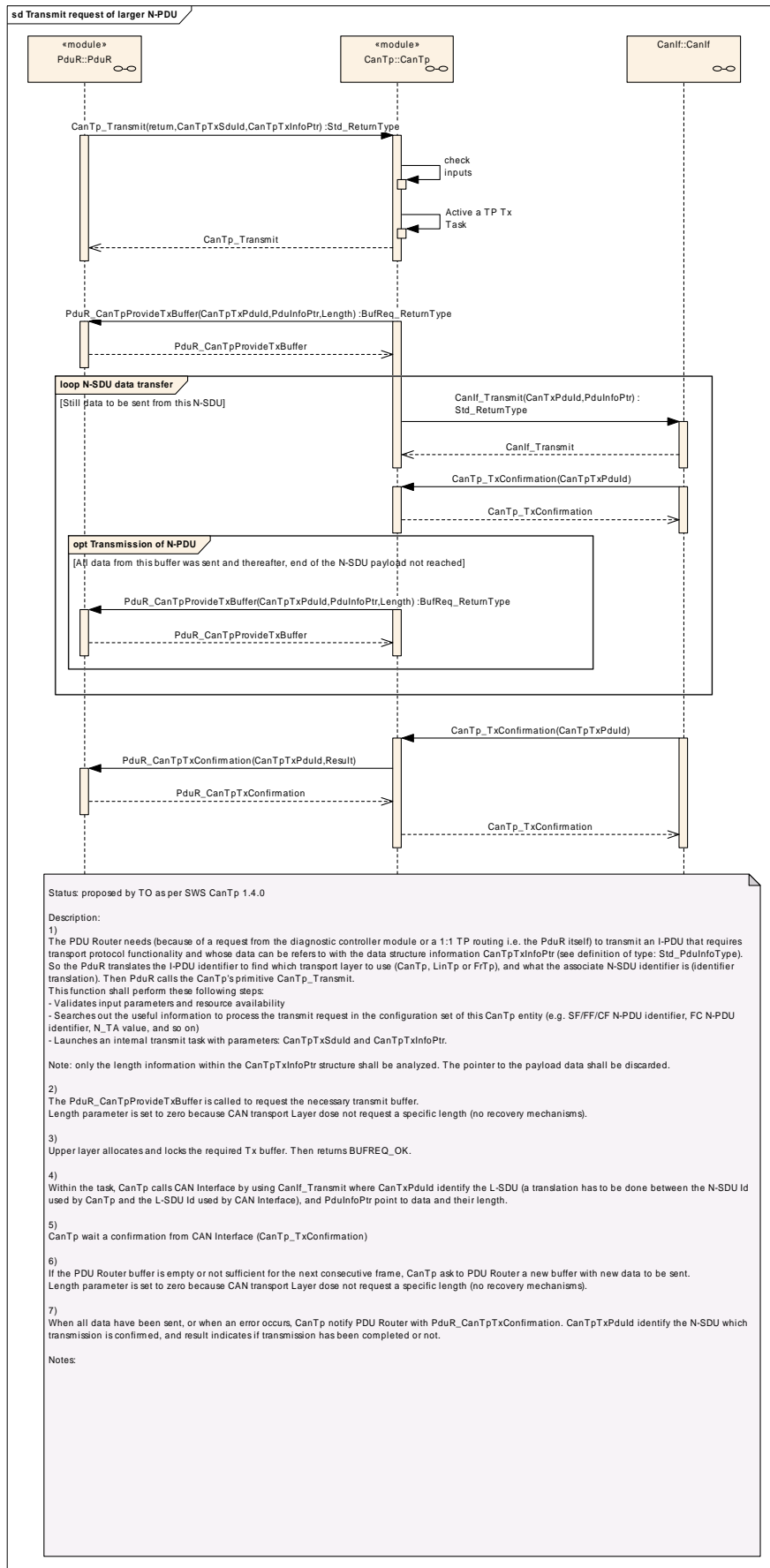

9.4.3 Transition description

Transition	Name	Description
1	<pre>CanTp_Transmit (CanTpTxSduId, CanTpTxInfoPtr)</pre>	<p>The PDU Router needs (because of a request from the diagnostic controller module or a 1:1 TP routing – i.e. the PduR itself) to transmit an I-PDU that requires transport protocol functionality and whose data can be referred to with the data structure information <code>CanTpTxInfoPtr</code> (see definition of type: <code>Std_PduInfoType</code>).</p> <p>Thus, the PduR translates the I-PDU identifier to establish which transport layer to use (<code>CanTp</code>, <code>LinTp</code> or <code>FrTp</code>), and what the associate N-SDU identifier is (identifier translation). Then PduR calls the <code>CanTp</code>'s primitive <code>CanTp_Transmit</code>.</p> <p>This function should perform the following steps:</p> <ul style="list-style-type: none"> - Validate input parameters and resource availability - Search for the useful information to process the transmit request in the configuration set of this <code>CanTp</code> entity (e.g. SF/FF/CF N-PDU identifier, FC N-PDU identifier, N_TA value, and so on) - Launch an internal transmit task with parameters: <code>CanTpTxSduId</code> and <code>CanTpTxInfoPtr</code>. <p>Note: only information concerning length within the <code>CanTpTxInfoPtr</code> structure will be analyzed. The indicator to the payload data should be discarded.</p>
2	<pre>PduR_CanTpProvideTxBuffer (CanTpTxSduId, PduInfoPtr, Length=0)</pre>	<p>The <code>PduR_CanTpProvideTxBuffer</code> is called upon to request the necessary transmit buffer.</p> <p>Length parameter is set to zero because the CAN transport Layer does not request a specific length (no recovery mechanism).</p>
3	BUFREQ_OK	<p>The upper layer allocates and locks the required Tx buffer. Then returns <code>BUFREQ_OK</code>.</p>
4	<pre>CanIf_Transmit (CanTxPduId, PduInfoPtr)</pre>	<p>Within the task, <code>CanTp</code> calls the CAN Interface by using <code>CanIf_Transmit</code>, where <code>CanTxPduId</code> identifies the L-SDU (a translation has to be preformed between the N-SDU Id used by <code>CanTp</code> and the L-SDU Id used by CAN Interface), and <code>PduInfoPtr</code> indicator data and their length.</p>
5	<pre>CanTp_TxConfirmation(CanTpTxPduId,)</pre>	<p><code>CanTp</code> awaits a confirmation from the CAN Interface (<code>CanTp_TxConfirmation</code>)</p>
6	<pre>PduR_CanTpProvideTxBuffer (CanTpTxTxSduId, PduInfoPtr, Length=0)</pre>	<p>If the PDU Router buffer is empty or not sufficient for the next consecutive frame, <code>CanTp</code> asks the PDU Router for a new buffer, with new data, to be sent.</p> <p>Length parameter is set to zero because the CAN transport Layer does not request a specific length (no recovery mechanism).</p>
7	<pre>PduR_CanTpTxConfirmation (CanTpTxSduId, Result)</pre>	<p>When all data has been sent, or when an error occurs, <code>CanTp</code> notifies the PDU Router by means of <code>PduR_CanTpTxConfirmation</code>. <code>CanTpTxPduId</code> informs the N-SDU which transmission has been confirmed, and <code>result</code> indicates whether the transmission has been completed or not.</p>

9.5 Large N-SDU Reception

9.5.1 Assumptions

- All input parameters are OK
- The N-SDU data length is larger than 7 bytes (6 bytes in case of extended addressing format)
- Reception is successfully processed

9.5.2 Sequence diagram

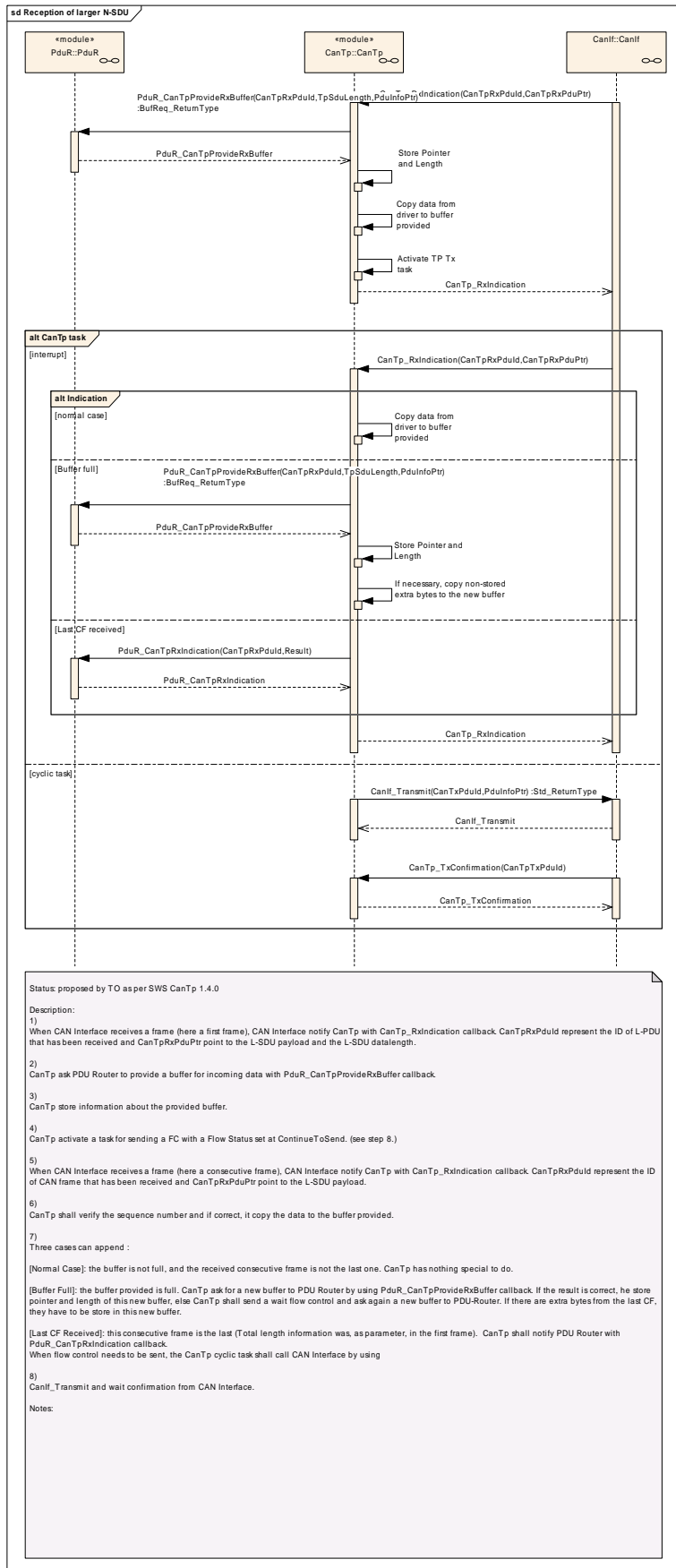

Note : This sequence diagram demonstrates the working of the CAN_Tp module only. However, if the whole system is considered in such reception, more modules are involved. Since this reception can be triggered in the context of a CAN ISR, the CAN Tp operation should be as short as possible.

9.5.3 Transition description

Transition	Name	Description
1	CanTp_RxIndication (CanTpRxPduId, CanTpRxPduPtr)	When the CAN Interface receives a frame (here a first frame), it notifies CanTp by means of a CanTp_RxIndication callback. CanTpRxPduId represents the ID of L-PDU that has been received and CanTpRxPduPtr indicates payload and L-SDU datalength to the L-SDU.
2	PduR_CanTpProvideRx Buffer (CanTpRxSduId, TpSduLength, PduInfoPtr)	CanTp asks the PDU Router to provide a buffer for incoming data by means of a PduR_CanTpProvideRxBuffer callback.
3		CanTp stores information about the buffer provided.
4		CanTp activates a task for sending an FC with a Flow Status set to ContinueToSend. (see step 8.)
5	CanTp_RxIndication (CanTpRxPduId, CanTpRxPduPtr)	When the CAN Interface receives a frame (here a consecutive frame), CAN Interface notifies CanTp by means of a CanTp_RxIndication callback. CanTpRxPduId represents the ID of the CAN frame that has been received and CanTpRxPduPtr indicates payload to the L-SDU.
6		CanTp will verify the sequence number and if correct, copy the data to the buffer provided.
7	Nothing or PduR_CanTpProvideRx Buffer (CanTpRxSduId, TpSduLength, PduInfoPtr) Or PduR_CanTpRxIndicat ion (CanTpRxSduId, Result)	Three cases can append : - [Normal Case]: the buffer is not full, and the received consecutive frame is not the last one. CanTp has nothing special to do. - [Buffer Full]: the buffer provided is full. CanTp asks the PDU Router for a new buffer by means of a PduR_CanTpProvideRxBuffer callback. If the result is correct, it stores the indication and length of this new buffer. Otherwise CanTp sends a wait flow control and asks the PDU-Router once again for a new buffer. If there are extra bytes from the last CF, they have to be stored in this new buffer. - [Last CF Received]: this consecutive frame is the last (Total length information is known using the FF_DL parameter in the first frame). CanTp notifies PDU Router by means of a PduR_CanTpRxIndication callback.
8		When flow control needs to be sent, the CanTp cyclical task should call the CAN Interface by using CanIf_Transmit and await confirmation from the CAN Interface.

10 Configuration specification

This chapter defines configuration parameters and their clustering into containers. In order to support the specification, Chapter 10.1 describes fundamentals.

Chapter 10.2 specifies the structure (containers) and the parameters of the module CAN Transport Layer.

Chapter 10.3 specifies published information for the module CAN Transport Layer

CanTp146: The listed configuration items can be derived from a network description database, which is based on the EcuConfigurationTemplate. The configuration tool should extract all information to configure the CAN Transport Protocol.

CanTp147: The consistency of the configuration must be checked by the configuration tool at configuration time. Configuration rules and constraints for plausibility checks will be performed where possible, during configuration time.

10.1 How to read this chapter

In addition to this section, it is highly recommended to read the documents:

- AUTOSAR Layered Software Architecture [2]
- AUTOSAR ECU Configuration Specification [4]. This document describes the AUTOSAR configuration methodology and the AUTOSAR configuration metamodel in detail.

The following is only a short survey of the topic and will not replace the ECU Configuration Specification document.

10.1.1 Configuration and configuration parameters

Configuration parameters define the variability of the generic part(s) of an implementation of a module. This means that only generic or configurable module implementation can be adapted to the environment (software/hardware) in use during system and/or ECU configuration.

The configuration of parameters can be achieved at different times during the software process: before compile time, before link time or after build time. In the following, the term “configuration class” (of a parameter) will be used in order to refer to a specific point in time during configuration.

10.1.2 Variants

Variants describe sets of configuration parameters. E.g. variant 1: only pre-compile time configuration parameters, variant 2: mix of pre-compile- and post build time-configuration parameters. In one variant, a parameter can only be of one configuration class.

10.1.3 Containers

Containers structure the set of configuration parameters. This means:

- *all* configuration parameters are kept in containers.
- (sub-) containers can reference (sub-) containers. It is possible to assign a multiplicity to these references. This multiplicity defines the possible number of occurrences of the contained parameters.

10.1.4 Specification template for configuration parameters

The following tables consist of three sections:

- general section
- configuration parameter section
- section of included/referenced containers

SWS Item	
Container Name	Identifies the container with a name
Description	Explains the intention and content of the container.
Configuration Parameters	

Name	Identifies the parameter by name.		
Description	Explains the intention of the configuration parameter.		
Type or Unit	Specifies the type of parameter (e.g., uint8..uint32) or specifies the unit of the parameter (e.g., ms)		
Range	Specifies the range (or possible values) of the parameter (e.g., 1..15, ON, OFF)	Describes the value(s) or range(s).	
Configuration Class	Pre-compile	see ³	Refer here to (a) variant(s).
	Link time	see ⁴	Refer here to (a) variant(s).
	Post Build	see ⁵	Refer here to (a) variant(s).
Scope	Describes the scope of the parameter. The scope describes the impact of the configuration parameter: Does the setting affect only one instance of the module (instance), all instances of this module (module), the ECU or a network? Possible values of scope : instance, module, ECU, network		
Dependency	Describes the dependencies with respect to the scope.		

³ see the explanation below this table - Pre-compile time

⁴ see the explanation below this table - Link time

⁵ see the explanation below this table - Post Build

Included Containers		
Container Name	Multiplicity	Scope / Dependency
Reference a valid (sub)container by its name.	Specifies the number of possible instances of the referenced container and its contained configuration parameters. Possible values: <multiplicity> <min_multiplicity..max_multiplicity>	Describes the scope of the referenced sub-container. The scope describes the impact of the configuration parameter: Does the setting affect only one instance of the module (instance), all instances of this module (module), the ECU or a network? Possible values of scope : instance, module, ECU, network> Describes the dependencies with respect to the scope.

Pre-compile time - specifies whether the configuration parameter will be of the configuration class *Pre-compile time* or not

Label	Description
x	The configuration parameter will be of configuration class <i>Pre-compile time</i> .
--	The configuration parameter will never be of configuration class <i>Pre-compile time</i> .

Link time - specifies whether the configuration parameter will be of configuration class *Link time* or not

Label	Description
x	The configuration parameter will be of configuration class <i>Link time</i> .
--	The configuration parameter will never be of configuration class <i>Link time</i> .

Post Build - specifies whether the configuration parameter will be of configuration class *Post Build* or not

Label	Description
x	The configuration parameter will be of configuration class <i>Post Build</i> and no specific implementation is required.
L	<i>Loadable</i> - the configuration parameter will be of configuration class <i>Post Build</i> and only one configuration parameter set resides in the ECU.
M	<i>Multiple</i> - the configuration parameter will be of configuration class <i>Post Build</i> and is selected from a set of multiple parameters by passing a dedicated pointer to the init function of the module.
--	The configuration parameter will never be of configuration class <i>Post Build</i> .

10.2 Containers and configuration parameters

The following chapters summarize all configuration parameters. The detailed meanings of the parameters are described in Chapters 7 and 8.

10.2.1 Variants

Variant 1: all parameters are configured at compile time.

Variant 2: some parameters are configured at compile time, some parameters are configured at post build time.

10.2.2 CanTp

Module Name	CanTp
Module Description	Configuration of the CanTp (CAN Transport Protocol) module.

Included Containers		
Container Name	Multiplicity	Scope / Dependency
CanTpGeneral	1	This container contains the general configuration parameters of the CanTp module.
CanTpRxNSdu	0..*	The following parameters needs to be configured for each CAN N-SDU that the CanTp module shall receive.
CanTpTxNSdu	0..*	The following parameters needs to be configured for each CAN N-SDU that the CanTp module shall transmitt.

10.2.3 CanTpGeneral

SWS Item	CanTp238 :		
Container Name	CanTpGeneral{CanTpConfiguration}		
Description	This container contains the general configuration parameters of the CanTp module.		
Configuration Parameters			

SWS Item	CanTp239 :		
Name	CanTpDevErrorDetect {CANTP_DEV_ERROR_DETECT}		
Description	Switches the Development Error Detection and Notification ON or OFF		
Multiplicity	1		
Type	BooleanParamDef		
Default value	--		
ConfigurationClass	Pre-compile time	X	All Variants
	Link time	--	
	Post-build time	--	
Scope / Dependency	scope: Module		

SWS Item	CanTp240 :		
Name	CanTpMainFunctionPeriod {CANTP_MAIN_FUNCTION_PERIOD}		
Description	Allow to configure the time for the MainFunction (as float in seconds). Please note: This configuration value shall be equal to the value in the ScheduleManger module.		
Multiplicity	1		
Type	FloatParamDef		
Range	0.0 .. 0.255		
Default value	--		
ConfigurationClass	Pre-compile time	X	VARIANT-PRE-COMPILE
	Link time		

	Link time	--	
	Post-build time	L	VARIANT-POST-BUILD
Scope / Dependency	scope: ECU		

SWS Item	CanTp242 :		
Name	CanTpTc {CANTP_TC}		
Description	Preprocessor switch for enabling Transmit Cancellation.		
Multiplicity	1		
Type	BooleanParamDef		
Default value	--		
ConfigurationClass	Pre-compile time	X	All Variants
	Link time	--	
	Post-build time	--	
Scope / Dependency	scope: ECU		

No Included Containers

10.2.4 CanTpRxNSdu

SWS Item	CanTp137 :		
Container Name	CanTpRxNSdu{RxNsdu}		
Description	The following parameters needs to be configured for each CAN N-SDU that the CanTp module shall receive.		
Configuration Parameters			

SWS Item	CanTp242 :		
Name	CanTpAddressingFormat {CANTP_ADDRESSING_FORMAT}		
Description	Declares which communication addressing mode is supported for this Rx N-SDU. Enum values: CanTpStandard. To use normal addressing format. CanTpExtended. To use extended addressing format.		
Multiplicity	1		
Type	EnumerationParamDef		
Range	CANTP_EXTENDED	Extended addressing format	
	CANTP_STANDARD	Standard addressing format	
ConfigurationClass	Pre-compile time	X	All Variants
	Link time	--	
	Post-build time	--	
Scope / Dependency	scope: Module		

SWS Item	CanTp243 :		
Name	CanTpBs {CANTP_BS}		
Description	Sets the maximum number of N-PDUs the CanTp receiver allows the sender to send, before waiting for an authorization to continue transmission of the following N-PDUs. For further details on this parameter value see ISO 15765-2 specification. Note: For reasons of buffer length, the CAN Transport Layer can adapt the BS value within the limit of this maximum BS		
Multiplicity	1		
Type	IntegerParamDef		
Default value	--		
ConfigurationClass	Pre-compile time	X	VARIANT-PRE-COMPILE
	Link time	--	
	Post-build time	L	VARIANT-POST-BUILD
Scope / Dependency	scope: Module		

SWS Item	CanTp244 :		
Name	CanTpNar {CANTP_NAR}		
Description	Value in seconds of the N_Ar timeout. N_Ar is the time for transmission of a CAN frame (any N_PDU) on the receiver side.		
Multiplicity	1		
Type	FloatParamDef		
Default value	--		
ConfigurationClass	Pre-compile time	X	VARIANT-PRE-COMPILE
	Link time	--	
	Post-build time	L	VARIANT-POST-BUILD
Scope / Dependency	scope: Module		

SWS Item	CanTp245 :		
Name	CanTpNbr {CANTP_NBR}		
Description	Value in seconds of the performance requirement for (N_Br + N_Ar). N_Br is the elapsed time between the receiving indication of a FF or CF or the transmit confirmation of a FC, until the transmit request of the next FC.		
Multiplicity	1		
Type	FloatParamDef		
Default value	--		
ConfigurationClass	Pre-compile time	X	VARIANT-PRE-COMPILE
	Link time	--	
	Post-build time	L	VARIANT-POST-BUILD
Scope / Dependency	scope: Module		

SWS Item	CanTp246 :		
Name	CanTpNcr {CANTP_NCR}		
Description	Value in seconds of the N_Cr timeout. N_Cr is the time until reception of the next Consecutive Frame N_PDU.		
Multiplicity	1		
Type	FloatParamDef		
Default value	--		
ConfigurationClass	Pre-compile time	X	VARIANT-PRE-COMPILE
	Link time	--	
	Post-build time	L	VARIANT-POST-BUILD
Scope / Dependency	scope: Module		

SWS Item	CanTp247 :		
Name	CanTpRxChannel {CANTP_RX_CHANNEL}		
Description	Link to the Rx connection channel, which has to be used for receiving this N-PDU.		
Multiplicity	1		
Type	IntegerParamDef		
Default value	--		
ConfigurationClass	Pre-compile time	X	All Variants
	Link time	--	
	Post-build time	--	
Scope / Dependency	scope: Module		

SWS Item	CanTp248 :		
Name	CanTpRxDI {CANTP_DL}		
Description	Data Length Code of this RxNsd. In case of variable message length, this value indicates the minimum data length. Depending on SF or FF N-SDU the value will be limited to 7 (6 for an extended addressing format) and 4095 respectively.		

Multiplicity	1		
Type	IntegerParamDef		
Default value	--		
ConfigurationClass	Pre-compile time	X	All Variants
	Link time	--	
	Post-build time	--	
Scope / Dependency	scope: Module		

SWS Item	CanTp249 :		
Name	CanTpRxPaddingActivation {CANTP_PADDING_ACTIVATION}		
Description	Defines if the receive frame uses padding or not. Definition of enumeration values: CanTpOn: The N-PDU received uses padding for SF, FC and the last CF. (N-PDU length is always 8 bytes) CanTpOff: The N-PDU received does not use padding for SF, CF and the last CF. (N-PDU length is dynamic)		
Multiplicity	1		
Type	EnumerationParamDef		
Range	CANTP_OFF	Padding is not used	
	CANTP_ON	Padding is used	
ConfigurationClass	Pre-compile time	X	All Variants
	Link time	--	
	Post-build time	--	
Scope / Dependency	scope: Module		

SWS Item	CanTp250 :		
Name	CanTpRxTaType {CANTP_TA_TYPE}		
Description	Declares the communication type of this Rx N-SDU.		
Multiplicity	1		
Type	EnumerationParamDef		
Range	CANTP_FUNCTIONAL	Functional request type	
	CANTP_PHYSICAL	Physical request type	
ConfigurationClass	Pre-compile time	X	All Variants
	Link time	--	
	Post-build time	--	
Scope / Dependency	scope: Module		

SWS Item	CanTp251 :		
Name	CanTpRxWftMax {CANTP_WFTMAX}		
Description	This parameter indicates how many Flow Control wait N-PDUs can be consecutively transmitted by the receiver. It is local to the node and is not transmitted inside the FC protocol data unit. CanTpRxWftMax is used to avoid sender nodes being potentially hooked-up in case of a temporarily reception inability on the part of the receiver nodes, whereby the sender could be waiting continuously.		
Multiplicity	1		
Type	IntegerParamDef		
Default value	--		
ConfigurationClass	Pre-compile time	X	VARIANT-PRE-COMPILE
	Link time	--	
	Post-build time	L	VARIANT-POST-BUILD
Scope / Dependency	scope: Module		

SWS Item	CanTp252 :		
Name	CanTpSTmin {CANTP_STMIN}		
Description	Sets the duration of the minimum time the CanTp sender shall wait between the transmissions of two CF N-PDUs. For further details on this		

	parameter value see ISO 15765-2 specification.		
Multiplicity	1		
Type	IntegerParamDef		
Default value	--		
ConfigurationClass	Pre-compile time	X	VARIANT-PRE-COMPILE
	Link time	--	
	Post-build time	L	VARIANT-POST-BUILD
Scope / Dependency	scope: Module		

SWS Item	CanTp241 :		
Name	CanTpRxNSduRef		
Description	Reference to a Pdu in the COM-Stack.		
Multiplicity	1		
Type	Reference to Pdu		
ConfigurationClass	Pre-compile time	X	VARIANT-PRE-COMPILE
	Link time	X	VARIANT-POST-BUILD
	Post-build time	--	
Scope / Dependency			

Included Containers		
Container Name	Multiplicity	Scope / Dependency
CanTpNSa	0..1	Contains the parameters needed to configure each RxNSdu or TxNSdu with CanTpAddressingFormat set to CanTpExtended.
CanTpNTa	0..1	The following parameters need to be configured for each RxNSdu or TxNSdu with the CanTpAddressingFormat set to CanTpExtended.
CanTpRxNPdu	1	Used for grouping of the ID of a PDU and the Reference to a PDU.
CanTpTxFcNPdu	0..1	Used for grouping of the ID of a PDU and the Reference to a PDU.

10.2.5 CanTpRxNPdu

SWS Item	CanTp256 :		
Container Name	CanTpRxNPdu		
Description	Used for grouping of the ID of a PDU and the Reference to a PDU.		
Configuration Parameters			

SWS Item	CanTp258 :		
Name	CanTpRxNPduId {CAN_TP_RXNPDU_ID}		
Description	The N-PDU identifier attached to the RxNSdu is identified by CanTpRxNSduId. Each RxNSdu identifier is linked to only one SF/FF/CF N-PDU identifier. Nevertheless, in the case of extended addressing format, the same N-PDU identifier can be used for several N-SDU identifiers. The distinction is made by the N_TA value (first data byte of SF or FF frames).		
Multiplicity	1		
Type	IntegerParamDef (Symbolic Name generated for this parameter)		
Default value	--		
ConfigurationClass	Pre-compile time	X	All Variants
	Link time	--	
	Post-build time	--	
Scope / Dependency	scope: module		

SWS Item	CanTp257 :		
Name	CanTpRxNPduRef		
Description	Reference to a Pdu in the COM-Stack.		

Multiplicity	1		
Type	Reference to Pdu		
ConfigurationClass	Pre-compile time	X	VARIANT-PRE-COMPILE
	Link time	--	
	Post-build time	L	VARIANT-POST-BUILD
Scope / Dependency			

No Included Containers

10.2.6 CanTpTxFcNPdu

SWS Item	CanTp259 :		
Container Name	CanTpTxFcNPdu		
Description	Used for grouping of the ID of a PDU and the Reference to a PDU.		
Configuration Parameters			

SWS Item	CanTp260 :		
Name	CanTpTxFcNPduRef		
Description	Reference to a Pdu in the COM-Stack.		
Multiplicity	1		
Type	Reference to Pdu		
ConfigurationClass	Pre-compile time	X	VARIANT-PRE-COMPILE
	Link time	--	
	Post-build time	L	VARIANT-POST-BUILD
Scope / Dependency			

No Included Containers

10.2.7 CanTpTxNSdu

SWS Item	CanTp138 :		
Container Name	CanTpTxNSdu{TxNsdu}		
Description	The following parameters needs to be configured for each CAN N-SDU that the CanTp module shall transmitt.		
Configuration Parameters			

SWS Item	CanTp262 :		
Name	CanTpAddressingMode {CANTP_ADDRESSING_MODE}		
Description	Declares which communication addressing format is supported for this TxNsdu. Definition of Enumeration values: CanTpStandard to use normal addressing format. CanTpExtended to use extended addressing format (the N_TA container of this TxNsdu will be used).		
Multiplicity	1		
Type	EnumerationParamDef		
Range	CANTP_EXTENDED	Extended addressing format	
	CANTP_STANDARD	Standard addressing format	
ConfigurationClass	Pre-compile time	X	All Variants
	Link time	--	
	Post-build time	--	
Scope / Dependency	scope: Module		

SWS Item	CanTp263 :		
Name	CanTpNas {CANTP_NAS}		
Description	Value in second of the N_As timeout. N_As is the time for transmission of a CAN frame (any N_PDU) on the part of the sender.		
Multiplicity	1		

Type	FloatParamDef		
Default value	--		
ConfigurationClass	Pre-compile time	X	VARIANT-PRE-COMPILE
	Link time	--	
	Post-build time	L	VARIANT-POST-BUILD
Scope / Dependency	scope: Module		

SWS Item	CanTp264 :		
Name	CanTpNbs {CANTP_NBS}		
Description	Value in seconds of the N_Bs timeout. N_Bs is the time of transmission until reception of the next Flow Control N_PDU.		
Multiplicity	1		
Type	FloatParamDef		
Default value	--		
ConfigurationClass	Pre-compile time	X	VARIANT-PRE-COMPILE
	Link time	--	
	Post-build time	L	VARIANT-POST-BUILD
Scope / Dependency	scope: Module		

SWS Item	CanTp265 :		
Name	CanTpNcs {CANTP_NCS}		
Description	Value in seconds of the performance requirement of (N_Cs + N_As). N_Cs is the time which elapses between the transmit request of a CF N-PDU until the transmit request of the next CF N-PDU.		
Multiplicity	1		
Type	FloatParamDef		
Default value	--		
ConfigurationClass	Pre-compile time	X	VARIANT-PRE-COMPILE
	Link time	--	
	Post-build time	L	VARIANT-POST-BUILD
Scope / Dependency	scope: Module		

SWS Item	CanTp266 :		
Name	CanTpTxChannel {CANTP_TX_CHANNEL}		
Description	Link to the connection channel which has to be used for transmission of this N-PDU.		
Multiplicity	1		
Type	IntegerParamDef		
Default value	--		
ConfigurationClass	Pre-compile time	X	All Variants
	Link time	--	
	Post-build time	--	
Scope / Dependency	scope: Module		

SWS Item	CanTp267 :		
Name	CanTpTxDI {CANTP_DL}		
Description	Data Length Code of this TxNsdu. In case of variable length message, this value indicates the minimum data length.		
Multiplicity	1		
Type	IntegerParamDef		
Default value	--		
ConfigurationClass	Pre-compile time	X	All Variants
	Link time	--	
	Post-build time	--	
Scope / Dependency	scope: Module		

SWS Item	CanTp268 :		
Name	CanTpTxNSduId {CANTP_TXNSDU_ID}		
Description	Unique identifier to a structure that contains all useful information to process the transmission of a TxNsdu.		
Multiplicity	1		
Type	IntegerParamDef (Symbolic Name generated for this parameter)		
Default value	--		
ConfigurationClass	Pre-compile time	X	All Variants
	Link time	--	
	Post-build time	--	
Scope / Dependency	scope: Module		

SWS Item	CanTp269 :		
Name	CanTpTxPaddingActivation {CANTP_PADDING_ACTIVATION}		
Description	Defines if the transmit frame use padding or not. Definition of Enumeration values: CanTpOn The transmit N-PDU uses padding for SF, FC and the last CF. (N-PDU length is always 8 bytes) CanTpOff The transmit N-PDU does not use padding for SF, CF and the last CF. (N-PDU length is dynamic)		
Multiplicity	1		
Type	EnumerationParamDef		
Range	CANTP_OFF	Padding is not used	
	CANTP_ON	Padding is used	
ConfigurationClass	Pre-compile time	X	All Variants
	Link time	--	
	Post-build time	--	
Scope / Dependency	scope: Module		

SWS Item	CanTp270 :		
Name	CanTpTxTaType {CANTP_TA_TYPE}		
Description	Declares the communication type of this TxNsdu. Enumeration values: CanTpPhysical. Used for 1:1 communication. CanTpFunctional. Used for 1:n communication.		
Multiplicity	1		
Type	EnumerationParamDef		
Range	CANTP_FUNCTIONAL	Functional request type	
	CANTP_PHYSICAL	Physical request type	
ConfigurationClass	Pre-compile time	X	All Variants
	Link time	--	
	Post-build time	--	
Scope / Dependency	scope: Module		

SWS Item	CanTp261 :		
Name	CanTpTxNSduRef		
Description	Reference to a Pdu in the COM-Stack.		
Multiplicity	1		
Type	Reference to Pdu		
ConfigurationClass	Pre-compile time	X	VARIANT-PRE-COMPILE
	Link time	X	VARIANT-POST-BUILD
	Post-build time	--	
Scope / Dependency			

Included Containers		
Container Name	Multiplicity	Scope / Dependency

CanTpNSa	0..1	Contains the parameters needed to configure each RxNSdu or TxNSdu with CanTpAddressingFormat set to CanTpExtended.
CanTpNTa	0..1	The following parameters need to be configured for each RxNsdu or TxNsdu with the CanTpAddressingFormat set to CanTpExtended.
CanTpRxFcNPdu	0..1	Used for grouping of the ID of a PDU and the Reference to a PDU.
CanTpTxNPdu	1	Used for grouping of the ID of a PDU and the Reference to a PDU.

10.2.8 CanTpTxNPdu

SWS Item	CanTp274 :		
Container Name	CanTpTxNPdu		
Description	Used for grouping of the ID of a PDU and the Reference to a PDU.		
Configuration Parameters			

SWS Item	CanTp275 :		
Name	CanTpTxNPduRef		
Description	Reference to a Pdu in the COM-Stack.		
Multiplicity	1		
Type	Reference to Pdu		
ConfigurationClass	Pre-compile time	X	VARIANT-PRE-COMPILE
	Link time	--	
	Post-build time	X	VARIANT-POST-BUILD
Scope / Dependency			

No Included Containers

10.2.9 CanTpRxFcNPdu

SWS Item	CanTp271 :		
Container Name	CanTpRxFcNPdu		
Description	Used for grouping of the ID of a PDU and the Reference to a PDU.		
Configuration Parameters			

SWS Item	CanTp273 :		
Name	CanTpRxFcNPduId {CANTP_RXFC_NPDU_ID}		
Description	N-PDU identifier attached to the FC N-PDU of this TxNsdu identified by CanTpTxNSduId. Each TxNsdu identifier is linked to one Rx FC N-PDU identifier only. However, in the case of extended addressing format, the same FC N-PDU identifier can be used for several N-SDU identifiers. The distinction is made by means of the N_TA value (first data byte of FC frames).		
Multiplicity	1		
Type	IntegerParamDef (Symbolic Name generated for this parameter)		
Default value	--		
ConfigurationClass	Pre-compile time	X	All Variants
	Link time	--	
	Post-build time	--	
Scope / Dependency	scope: Module		

SWS Item	CanTp272 :		
Name	CanTpRxFcNPduRef		
Description	Reference to a Pdu in the COM-Stack.		
Multiplicity	1		
Type	Reference to Pdu		

ConfigurationClass	Pre-compile time	X	VARIANT-PRE-COMPILE
	Link time	--	
	Post-build time	L	VARIANT-POST-BUILD
Scope / Dependency			

No Included Containers

10.2.10 CanTpNTa

SWS Item	CanTp139 :		
Container Name	CanTpNTa{N_Ta}		
Description	The following parameters need to be configured for each RxNsdu or TxNsdu with the CanTpAddressingFormat set to CanTpExtended.		
Configuration Parameters			

SWS Item	CanTp255 :		
Name	CanTpNTa {CANTP_NTA}		
Description	If an RxNsdu or a TxNsdu is configured for extended addressing format, this parameter contains the transport protocol target address's value.		
Multiplicity	1		
Type	IntegerParamDef		
Default value	--		
ConfigurationClass	Pre-compile time	X	All Variants
	Link time	--	
	Post-build time	--	
Scope / Dependency			
scope: Module			

No Included Containers

10.2.11 CanTpNSa

SWS Item	CanTp253 :		
Container Name	CanTpNSa{N_Sa}		
Description	Contains the parameters needed to configure each RxNSdu or TxNSdu with CanTpAddressingFormat set to CanTpExtended.		
Configuration Parameters			

SWS Item	CanTp254 :		
Name	CanTpNSa {CANTP_NSA}		
Description	If an RxNSdu ora TxNSdu is configured for extended addressing format, this parameter contains the transport protocol source address's value.		
Multiplicity	1		
Type	IntegerParamDef		
Default value	--		
ConfigurationClass	Pre-compile time	X	All Variants
	Link time	--	
	Post-build time	--	
Scope / Dependency			

No Included Containers

10.3 Published Information

Published information contains data defined by the implementer of the SW module that does not change when the module is adapted (i.e. configured) to the actual HW/SW environment. It thus contains version and manufacturer information.

The standard common published information like

vendorId (<Module>_VENDOR_ID),
moduleId (<Module>_MODULE_ID),
arMajorVersion (<Module>_AR_MAJOR_VERSION),
arMinorVersion (<Module>_AR_MINOR_VERSION),
arPatchVersion (<Module>_AR_PATCH_VERSION),
swMajorVersion (<Module>_SW_MAJOR_VERSION),
swMinorVersion (<Module>_SW_MINOR_VERSION),
swPatchVersion (<Module>_SW_PATCH_VERSION),
vendorApiInfix (<Module>_VENDOR_API_INFIX)

is provided in the BSW Module Description Template (see [12] Figure 4.1 and Figure 7.1).

Additional published parameters are listed below if applicable for this module.

11 Changes to Release 1

11.1 Deleted SWS Items

SWS Item	Rationale
CanTp004	Requirement obsolete
CanTp015	Covered by CanTp001
CanTp026	Requirement obsolete
CanTp036	Requirement obsolete
CanTp037	Requirement obsolete
CanTp038	Requirement obsolete
CanTp039	Requirement obsolete
CanTp097	Multiple connection now is available
CanTp099	Requirement partly wrong
CanTp288	No need for DEM status DEM_EVENT_STATUS_PREPASSED – RfC40397

11.2 Replaced SWS Items

SWS Item of Release 1	replaced by SWS Item	Rationale
CanTp005	CanTp101	Covered by CanTp101
CanTp007	CanTp101	Covered by CanTp101
CanTp025	CanTp140	modification of type
CanTp041	CanTp137	Grouping of requirement and modification of name
CanTp042	CanTp138	Grouping of requirement and modification of name
CanTp043	CanTp137	Grouping of requirement and modification of name
CanTp044	CanTp138	Grouping of requirement and modification of name
CanTp045	CanTp137	Grouping of requirement and modification of name
CanTp046	CanTp138	Grouping of requirement and modification of name
CanTp047	CanTp137	Grouping of requirement and modification of name
CanTp048	CanTp138	Grouping of requirement and modification of name
CanTp049	CanTp137	Grouping of requirement and modification of name
CanTp050	CanTp138	Grouping of requirement and modification of name
CanTp051	CanTp139	Grouping of requirement and modification of name
CanTp052	CanTp139	Grouping of requirement and modification of name
CanTp053	CanTp138	Grouping of requirement and modification of name
CanTp054	CanTp137	Grouping of requirement and modification of name
CanTp056	CanTp138	Grouping of requirement and modification of name
CanTp060	CanTp138	Grouping of requirement and modification of name
CanTp061	CanTp137	Grouping of requirement and modification of name
CanTp062	CanTp138	Grouping of requirement and modification of name
CanTp063	CanTp137	Grouping of requirement and modification of name
CanTp065	CanTp140	Grouping of requirement and modification of name
CanTp066	CanTp140	Grouping of requirement and modification of name
CanTp068	CanTp137	Grouping of requirement and modification of name
CanTp069	CanTp138	Grouping of requirement and modification of name
CanTp108	CanTp137	Grouping of requirement and modification of name
CanTp109	CanTp138	Grouping of requirement and modification of name
CanTp113	CanTp137	Grouping of requirement and modification of name

11.3 Changed SWS Items

SWS Item	Rationale
CanTp001	File structure deleted and reported to CanTp156
CanTp010	Modification of the figure : addition of CanTp_Shutdown call in CANTP_OFF
CanTp019	Addition of Range value for parameter Change CanTpRxPduPtr parameter to const
CanTp020	Addition of Range value for parameter
CanTp032	Addition of ISO 15765-4 reference
CanTp040	Change of parameter name
CanTp074	Requirement that CanIf confirms only successful transmission confirmation
CanTp075	Requirement for the CAN Tp behavior in case of transmission time-out
CanTp082	Requirement when the CAN Tp has to call again for a buffer to be provided
CanTp096	Addition of several connection management
CanTp114	Requirement that it is a pre-compile time configuration

11.4 Added SWS Items

SWS Item	Rationale
CanTp156	File structure from CanTp001 reworked in this requirement
CanTp119	ISO 15765-4
CanTp120	Concurrent connections
CanTp121	Concurrent connections
CanTp122	Concurrent connections
CanTp123	Concurrent connections
CanTp124	Concurrent connections
CanTp130	Dem.h file inclusion
CanTp132	CanTpDevErrorDetect switch
CanTp133	Production error detection
CanTp134	Development Error Tracer
CanTp137	RxNsDu Configuration
CanTp138	RxNsDu Configuration
CanTp139	CanTpNTa Configuration
CanTp140	Published information Configuration
CanTp146	Configuration tool
CanTp147	Configuration tool
CanTp150	Design rules
CanTp151	Design rules
CanTp152	Design rules
CanTp153	Design rules
CanTp155	Design rules
CanTp158	Design rules
CanTp156	File structure
CanTp157	CanTp.h file
CanTp158	Can Tp source code
CanTp159	Configuration files
CanTp160	Reference to c-configuration parameters
CanTp161	Initialization status variable
CanTp162	CanTp_GetVersionInfo Api
CanTp163	CanTp_GetVersionInfo Api

CanTp164	<i>MainFunction Api</i>
--------------------------	-------------------------

12 Changes during SWS Improvements by Technical Office

12.1 Deleted SWS Items

SWS Item	Rationale
CanTp118	No requirement, just description -> ID removed but text kept
CanTp016	No requirement, just description -> ID removed but text kept
CanTp014	No requirement, just description -> ID removed but text kept
CanTp022	No requirement, just description -> ID removed but text kept
CanTp034	No requirement, just description -> ID removed but text kept
CanTp032	No requirement, just description -> ID removed but text kept
CanTp119	No requirement, just description -> ID removed but text kept
CanTp070	No requirement, just description -> ID removed but text kept
CanTp073	No requirement, just description -> ID removed but text kept
CanTp012	No requirement, just description -> ID removed but text kept
CanTp013	No requirement, just description -> ID removed but text kept
CanTp085	No requirement, just description -> ID removed but text kept
CanTp112	No requirement, just description -> ID removed but text kept
CanTp058	No requirement, just description -> ID removed but text kept
CanTp135	No requirement for CanTp, text remove

12.2 Replaced SWS Items

SWS Item of Release 1	replaced by SWS Item	Rationale
CanTp028	CanTp168 , CanTp169	Made requirement atomic
CanTp029	CanTp170	Made requirement atomic (part became normal text)
CanTp071	CanTp176 , CanTp177	Made requirement atomic
CanTp088	CanTp184 , CanTp185	Made requirement atomic
CanTp018	CanTp199	Made requirement atomic
CanTp011	CanTp200 , CanTp202	Made requirement atomic
CanTp083	CanTp222 , CanTp223 , CanTp224	Made requirement atomic
CanTp110	CanTp225 , CanTp226	Made requirement atomic
CanTp103	CanTp231 , CanTp232	Made requirement atomic

12.3 Changed SWS Items

Many requirements have been changed to improve understandability without changing the technical contents.

12.4 Added SWS Items

SWS Item	Rationale
CanTp186	Requirement for CanTp module
CanTp190	Requirement for CanTp module
CanTp192	Standard template requirement

CanTp193	Standard template requirement
CanTp204	Requirement for function CanTp_Transmit
CanTp205	Requirement for function CanTp_Transmit
CanTp206	Requirement for function CanTp_Transmit
CanTp208	UML Model linking of CanTp_Init
CanTp209	UML Model linking of imported types
CanTp210	UML Model linking of CanTp_GetVersionInfo
CanTp211	UML Model linking of CanTp_Shutdown
CanTp212	UML Model linking of CanTp_Transmit
CanTp213	UML Model linking of CanTp_MainFunction
CanTp214	UML Model linking of CanTp_RxIndication
CanTp215	UML Model linking of CanTp_TxConfirmation
CanTp216	UML Model linking of mandatory interfaces
CanTp217	UML Model linking of optional interfaces
CanTp218	Gave ID to existing requirement
CanTp219	Gave ID to existing requirement
CanTp220	Gave ID to existing requirement
CanTp221	Gave ID to existing requirement
CanTp227	Gave ID to existing requirement
CanTp229	Gave ID to existing requirement
CanTp230	Gave ID to existing requirement
CanTp233	Gave ID to existing requirement
CanTp234	Gave ID to existing requirement
CanTp235	Gave ID to existing requirement
CanTp236	Gave ID to existing requirement
CanTp237	Gave ID to existing requirement
CanTp238	Gave ID to existing requirement