

Document Title	Specification of Intrusion Detection System Protocol
Document Owner	AUTOSAR
Document Responsibility	AUTOSAR
Document Identification No	981

Document Status	published
Part of AUTOSAR Standard	Foundation
Part of Standard Release	R24-11

Document Change History			
Date	Release	Changed by	Description
2024-11-27	R24-11	AUTOSAR Release Management	<ul style="list-style-type: none"> • Introduction of Context Data Version • Clarification on Context Data Length
2023-11-23	R23-11	AUTOSAR Release Management	<ul style="list-style-type: none"> • Correct Message Header Length
2022-11-24	R22-11	AUTOSAR Release Management	<ul style="list-style-type: none"> • No content changes
2021-11-25	R21-11	AUTOSAR Release Management	<ul style="list-style-type: none"> • Improved explanations of protocol fields • Increased consistency between overview and detailed tables • Corrections in frame size calculation
2020-11-30	R20-11	AUTOSAR Release Management	<ul style="list-style-type: none"> • Initial release

Disclaimer

This work (specification and/or software implementation) and the material contained in it, as released by AUTOSAR, is for the purpose of information only. AUTOSAR and the companies that have contributed to it shall not be liable for any use of the work.

The material contained in this work is protected by copyright and other types of intellectual property rights. The commercial exploitation of the material contained in this work requires a license to such intellectual property rights.

This work may be utilized or reproduced without any modification, in any form or by any means, for informational purposes only. For any other purpose, no part of the work may be utilized or reproduced, in any form or by any means, without permission in writing from the publisher.

The work has been developed for automotive applications only. It has neither been developed, nor tested for non-automotive applications.

The word AUTOSAR and the AUTOSAR logo are registered trademarks.

Contents

1	Introduction and overview	5
1.1	Protocol purpose and objectives	5
1.2	Applicability of the protocol	5
1.2.1	Constraints and assumptions	5
1.2.2	Limitations	5
1.3	Dependencies	6
1.3.1	Dependencies to other protocol layers	6
1.3.2	Dependencies to other standards and norms	6
1.3.3	Dependencies to the Application Layer	6
2	Use Cases	7
2.1	UC_0001 "Forward QSEv to ECU with SOC connection"	7
3	Protocol Requirements	8
3.1	Requirements Traceability	8
4	Definition of Terms and Acronyms	9
4.1	Acronyms and Abbreviation	9
5	Protocol specification	11
5.1	IDS Message Format	11
5.1.1	IDS Protocol Overview	12
5.1.2	Endianness - Byte Order	14
5.1.3	Independence of communication interface	14
5.1.4	IDS Event Frame	14
5.1.4.1	Protocol Version and Header	16
5.1.4.1.1	Protocol Version	16
5.1.4.1.2	Protocol Header	16
5.1.4.2	IdsM Instance ID and Sensor Instance ID	17
5.1.4.2.1	IdsM Instance ID	18
5.1.4.2.2	Sensor Instance ID	18
5.1.4.3	Event Definition ID	18
5.1.4.4	Count	19
5.1.4.5	Reserved	20
5.1.5	Timestamp	21
5.1.5.1	Timestamp AUTOSAR	22
5.1.5.1.1	Nanoseconds	22
5.1.5.1.2	Seconds	23
5.1.5.2	Timestamp OEM	24
5.1.6	Context Data	25
5.1.6.1	Context Data Version	25
5.1.6.2	Context Data - Size Long	26
5.1.6.3	Context Data - Size Short	27
5.1.7	Context Data Length Encoding	27

5.1.8	Signature	28
5.1.8.1	Signature Length	28
5.1.8.2	Signature Data	29
5.1.9	IDS Message Separation	30
5.1.9.1	IDS Message Separation Header	31
5.1.9.2	IDS Message Separation Header ID	31
5.1.9.3	IDS Message Separation Header Length	32
5.1.10	PDU Type	32
5.1.11	Example of IDS Messages	32
5.1.11.1	Example IDS Message with Maximum Size	32
5.1.11.2	Example IDS Message with minimum size	33
5.2	Message types	33
5.3	Services / Commands	34
5.4	Sequences (lower layer)	34
5.5	Error messages	34
6	Configuration parameters	35
7	Protocol usage and guidelines	36
A	Change history of AUTOSAR traceable items	37
A.1	Traceable item history of this document according to AUTOSAR Release R24-11	37
A.1.1	Added Specification Items in R24-11	37
A.1.2	Changed Specification Items in R24-11	37
A.1.3	Deleted Specification Items in R24-11	37

1 Introduction and overview

This Protocol Requirements Specification defines the format, message sequences and semantics of the AUTOSAR Protocol Intrusion Detection System (**IDS**).

The document RS IntrusionDetectionSystem [1] describes the elements of a distributed Intrusion Detection System (**IDS**). Please see [1] for an overview of the **IDS** elements.

The **PRS IDS** contributes to the **IDS** by providing the protocol for the transmission of qualified security events (**QSEv**) from an Intrusion Detection System Manager (**IdsM**) instance to an Intrusion Detection System Reporter (**IdsR**) instance.

1.1 Protocol purpose and objectives

As described in [1] **QSEv** can be persisted locally on the **ECU** where the *security event* was qualified. Alternatively a **QSEv** can be send to the **IdsR**. The **IDS protocol** covers the sending of the **QSEv** from the **IdsM** instance to the **IdsR** instance.

1.2 Applicability of the protocol

The **IDS protocol** supports a push-interface for **QSEv**. The **IdsM** instances push **QSEv** which are configured accordingly to the **IdsR**. A pull interface is not covered by this protocol. It could be realized by storing the **QSEv** locally in a appropriate component and then accessing the locally stored **QSEv** via regular diagnostic interfaces.

1.2.1 Constraints and assumptions

There are no specific assumptions and constraints for using the **IDS protocol**. It was designed to work for all bus system. The software stack must be able to send and receive **I-PDUs**. The **IdsM** does not support the reception of **QSEvs**.

1.2.2 Limitations

There is no limit defined for the context data size. The recommendation is to set the limit for a complete individual **QSEv** to 16 kByte.

1.3 Dependencies

1.3.1 Dependencies to other protocol layers

IdsM has dependencies to other protocol layers like **TCP**, **UDP** or **CAN** depending on the used network.

1.3.2 Dependencies to other standards and norms

The elements of the **IDS protocol** can be mapped to the syslog format by the **IdsR** if required for the **SOC**.

1.3.3 Dependencies to the Application Layer

The **IDS protocol** has no dependencies to the application layer. Application layer components can issue **security events** by using **API** of **IdsM**.

2 Use Cases

The AUTOSAR IDS architecture and functionality is described in [1]. Therefore this chapter is a brief summary of the use case for the protocol.

ID	Name	Description
0001	Transmission of QSEv of QSEv	Transmission of qualified security events from IdsM instances to IdsR instance

Table 2.1: Usecases for IDS protocols

2.1 UC_0001 "Forward QSEv to ECU with SOC connection"

The main use case for the **IDS protocol** is the propagation of Qualified Security Events **QSEv** to the **IdsR** in a way that is independent from the kind of **ECU** or the used communication mechanism. **IdsM** instances can be allocated to all nodes of the vehicle architecture that are security relevant. This decision is typically based on a security analysis of the vehicle E/E architecture. As a result an **IdsM** instance can be connected to the **IdsR** indirectly via a number of different bus systems as illustrated in **Figure 2.1**, which shows an example of **AP** and **CP**.

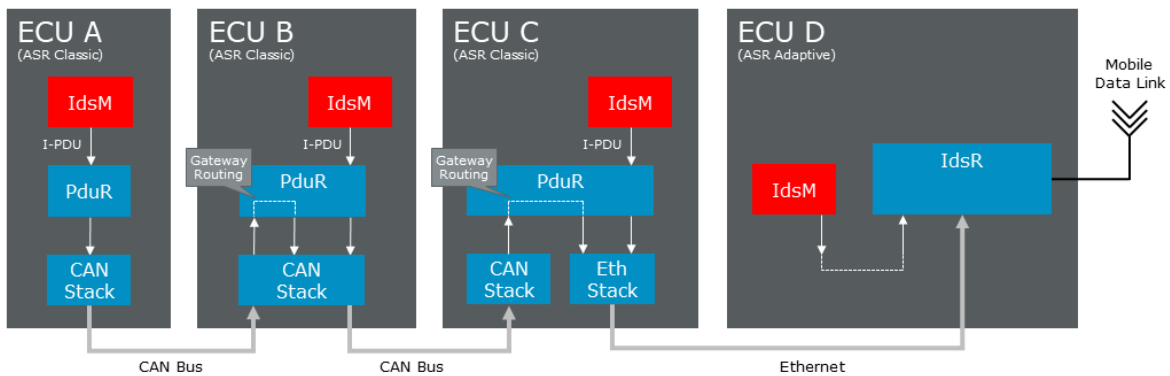

Figure 2.1: Use case for IDS protocol

3 Protocol Requirements

3.1 Requirements Traceability

The following tables reference the requirements specified in the IDS requirement specification [1] and links to the fulfillment of these.

Requirement	Description	Satisfied by
[RS_Ids_00502]	Event Timestamps	[PRS_Ids_00400] [PRS_Ids_00401]
[RS_Ids_00503]	Timestamp Sources	[PRS_Ids_00404]
[RS_Ids_00505]	Authenticity of QSEvs	[PRS_Ids_00600] [PRS_Ids_00601]
[RS_Ids_00510]	The IdsM shall allow to transmit QSEv to the IdsR	[PRS_Ids_00001]

Table 3.1: Requirements Tracing

4 Definition of Terms and Acronyms

4.1 Acronyms and Abbreviation

Acronym / Abbreviation	Description:
AP	AUTOSAR Adaptive Platform
API	Application Programming Interface
BSW	Standardized AUTOSAR Software modules, which provides basic functionalities usually required in electronic control unit.
CAN	Controller Area Network, an automotive network communication protocol.
CAN FD	Controller Area Network with Flexible Data-Rate
CDD	Complex Device Driver
Context Data	Relevant information to a Security Event (SEv). It is optional data that provides a broader understanding of the security event (e.g. the corrupted data). The content and encoding of the context data is externally defined by the sensor and unknown to the IdsM module.
Context Data Buffer	Buffer with variable sizes to fit to the needs of the context data of the SEvs.
CP	AUTOSAR Classic Platform
ECU	Electronic Control Unit which provides functionalities in electronic system of a car, e.g. brake system or window lifter.
Event Buffer	Buffer to temporarily store the reported SEv.
Event Frame	Main frame of IDS protocol which includes the basic information like the Security Event ID.
Filter Chain	A set of consecutive filters which is applied to security events. The output are Qualified Security Events.
FlexRay	An automotive network communication protocol.
General Purpose I-Pdu	General Purpose Interaction Layer Protocol Data Unit.
ID	Identifier
IDS	Intrusion Detection System is a security control which detects and processes security events.
I-PDU	Interaction Layer Protocol Data Unit
I-PDU Multiplexer	An AUTOSAR Basic Software module which specifies the protocol to multiplex multiple Pdus with one Protocol Control information.
IdsM	Intrusion Detection System Manager handles security events reported by security sensors.
IDS Message	Message which is send by the IdsM with the IDS protocol.
IdsR	Intrusion Detection System Reporter handles Qualified Security Events received from IdsM instances.
IDS protocol	Intrusion Detection System protocol specifies the message format which is used by IDS.
LIN	Local Interconnect Network: serial communication bus to connect sensors and actuators.
ms	Miliseconds
N-PDU	Network Layer Protocol Data Unit
OEM	Original Equipment Manufacturer
PDU Router	Protocol Data Unit Router is an AUTOSAR component responsible for routing of messages independent from underlying communication network.

Acronym / Abbreviation	Description:
PRS IDS	Protocol Requirement Specification Intrusion Detection System specification document which describes all elements of the IDS protocol.
QSEv	Security events which pass the filter chain are regarded as Qualified Security Events and are sent to the configured sink.
SecXT	The Security Extract specifies which security events are handled by IdsM instances and their configuration parameters.
SEv	Security Event are reported by BSW, CDD, SWC or other software components or applications to the IdsM.
Sem	Security Event Memory, a user defined diagnostic event memory which is independent from the primary diagnostic event memory.
Security Sensors	BSW, CDD, SWC or other software components or applications which report security events to the IdsM.
SIEM	Security Incident and Event Management, Technology concept to collect, correlate and analyze security incidents to detect a threat.
Sensor	Reporting identity that informs the IdsM module about SEvs. It can be a BSW module, a proprietary CDD or a SWC Application.
SOC	Security Operation Center is the backend of the IDS in which data can be processed and analysed.
SoAd	Socket Adaptor is a Basic Software module of AUTOSAR which creates interface between Pdu-Based communication on service level and socket based TCP/IP
SOME/IP	Scalable service-Oriented MiddlewarE over Internet Protocol
SWC	Software Component
TCP	Transmission Control Protocol
UDP	User Datagram Protocol

Table 4.1: Acronyms and Abbreviation

5 Protocol specification

[PRS_Ids_00001] Purpose

Upstream requirements: [RS_Ids_00510](#)

[The main purpose of the **IDS protocol** is the transmission of qualified security events (**QSEv**) from an Intrusion Detection System Manager (**IdsM**) instance to an Intrusion Detection System Reporter (**IdsR**) instance.]

5.1 IDS Message Format

The IDS protocol is shown in [Figure 5.1](#).



Figure 5.1: IDS Message including Signature

[PRS_Ids_00002] IDS Protocol Structure [The **IDS protocol** consists of the standard Event Frame and up to three optional fields. It provides several options to send only minimal data of **Qualified Security Event QSEv** or to extend this data with more details.

Beside the extension with a timestamp or context data, there is also the option to secure the data transport by adding a signature to every **QSEv**. The list below shows examples of configurations and explains the options.]

All options can be configured or switched off independent from each other, so a subset or combination of all options is possible.

1. **[PRS_Ids_00003] Standard Qualified Security Event** [Standard Qualified Security Event **QSEv** without further data.]

2. **[PRS_Ids_00400] QSEv with Timestamp**

Upstream requirements: [RS_Ids_00502](#)

[Qualified Security Event **QSEv** with *Timestamp*: If more precise timestamp is required in addition to the one provided for example by **IdsR**. The sensor or the **IdsM** can add timestamp to every **QSEv**.

This option must be set by corresponding configuration bit in the protocol header.]

(refer to [5.1.5 Timestamp](#))

3. **[PRS_Ids_00500] QSEv with Context Data** [Qualified Security Event **QSEv** with *Context Data*: The context data includes sensor specific information which are only forwarded to the sink. **IdSM** do not have knowledge on content or structure of this data.
This option must be set by corresponding configuration bit in the protocol header.]

(refer to [5.1.6 Context Data](#))

4. **[PRS_Ids_00600] QSEv with Signature**

Upstream requirements: [RS_Ids_00505](#)

[Qualified Security Event **QSEv** with *Signature*: If more secure communication of [security events](#) is required a signature can be added to every **QSEv**.
This option must be set by corresponding configuration bit in the protocol header.]

(refer to [5.1.8 Signature](#))

5.1.1 IDS Protocol Overview

In figure [Figure 5.2](#) you can find an overview on all elements of the **IDS protocol**.

FieldName	Length	Description of the data
Protocol Version	4 Bit	The version of the IdsM protocol
Protocol Header	4 Bit	IdsM protocol header information: Bit[0]: 0 - No Context Data Frame included, 1 - Context Data Frame included Bit[1]: 0 - No Timestamp included, 1 - Timestamp included Bit[2]: 0 - No Signature Frame included, 1 - Signature Frame included Bit[3]: reserved
IdsM Instance Id	10 Bit	Unique identifier of the sending IdsMinstance 0-1023
Module Instance Id	6 Bit	Identifier to differ between multiple instances of modules
Event Id	16 Bit	Unique identifier of a Security Event: Range of AUTOSAR internal IDs: 0...0x7FFF Range of Customer specific IDs: 0x8000...0xFFFF
Count	16 Bit	Number of IdsM calls which result in the current event after processing the configured filter, e.g. <i>EventAggregation</i>
Reserve	8 Bit	Reserved for future use
Timestamp	8 Bytes	Timestamp / Tickstamp when event was detected: (optional) Byte[0] Bit[7]=0: AUTOSAR Standard, Byte[0] Bit[6]: reserved Byte[0] Bit[7]=1: OEM Specific / Custom Timestamp Resolution in ms. Maybe not necessary for every event type. If not set, field is filled by IdsR. If not authentic time, IdsR might recalculate the time and insert a new value
Context Data Version	2 Bytes	Version of the IDS Context Data. To distinguish different versions (optional) Context Data Version Byte[0], Bit [7]=0: Original reported Context Data Context Data Version Byte[0], Bit [7]=1: Context Data provided by user callout
Context Data Length	1 or 4 Bytes	Length information of Context Data. Only available if Context Data exists (optional) Most Significant Bit of first byte Context Data signals if Context Data Length is encoded in 7 Bit or 31 Bit: Context Data Length Byte[0] Bit[7]=0: Length is encoded in 7 Bits - Context Data Length Byte[0] Bit[0..6] - Valid values: 1..127 Bytes Context Data Length Byte[0] Bit[7]=1: Length is encoded in 31 Bits - Context Data Length Byte[0] Bit[0..6], Byte[1..3] Bit[0..7] - Valid values: 1..(2 ³¹) - 1 Bytes Note: The 2 Bytes for Context Data is not included in the Context Data Length)
Context Data	1...(2 ³¹) -1 Bytes	Binary blob attached by the sensor: (optional) Modelled context data provided by corresponding sensor components
Signature Length	2 Bytes	Length information of Signature. Only available if Signature exists. (optional) Signature Byte[0..1]: Signature Length 1..65535 Bytes
Signature	1..65535 Bytes	Signature for authentication of security event: (option) Signature calculated with Eventframe + Optional Timestamp + Optional Context Data Signature Byte[2..n]: Signature Data - configurable via MetaModel

Figure 5.2: Intrusion Detection System Protocol Overview

5.1.2 Endianness - Byte Order

[PRS_Ids_00004] Byte and Bit order [The **IDS protocol** uses big endianness as byte order also known as Motorola format. This is equal to the network byte order, e.g. used by ethernet. In the tables and descriptions of this section, the byte numbers increase in the same sequence as the bytes are transmitted in the **IDS** message, starting from 0.

The first byte is the **Most Significant Byte (MSB)**, usually Byte 0 the last byte is the **Least Significant Byte (LSB)**.

The bit numbers decrease, the **most significant bit (msb)** of a byte being bit 7 and the **least significant bit (lsb)** 0.]

5.1.3 Independence of communication interface

[PRS_Ids_00005] Independence of IDS Protocol [The **IDS protocol** is independent from the used hardware and the underlying communication interface (e.g. CAN, Ethernet, FlexRay). It is optimised to fit to standard CAN bus communication with the minimum required information on **security event**. Also ethernet communication is applicable.]

5.1.4 IDS Event Frame

Figure 5.3 shows the **Event Frame** of **IDS protocol**.

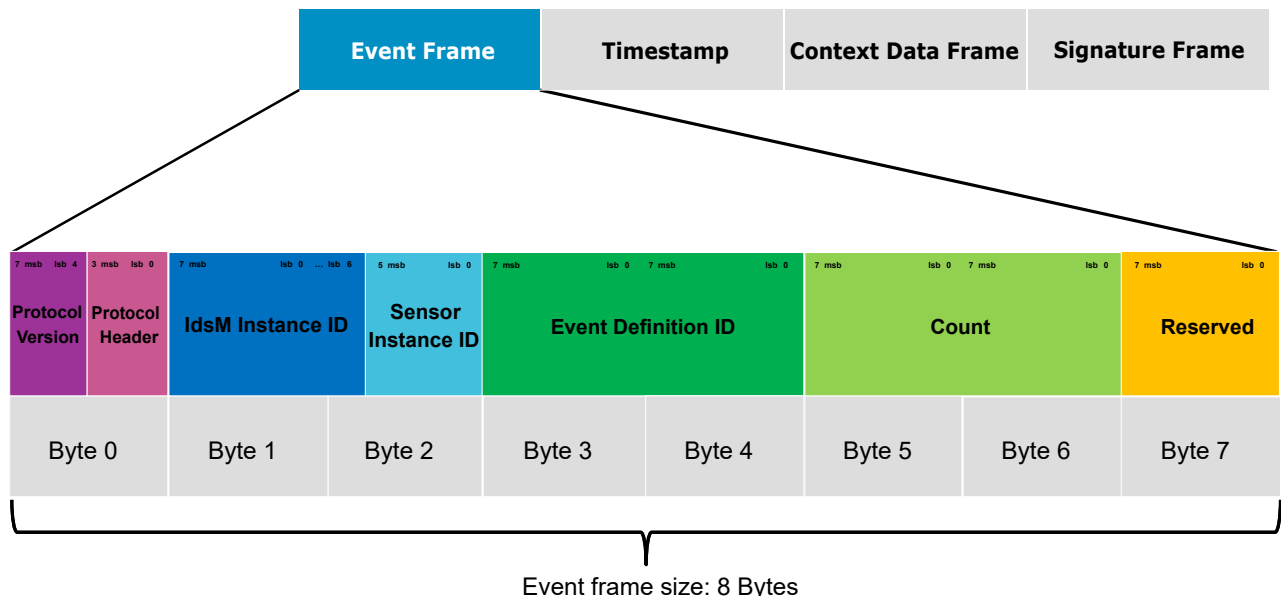

Figure 5.3: IDS Event Frame

[PRS_Ids_00006] Event Frame [The **IDS Event Frame** consists of 8 Byte as detailed above.]

Note:

[PRS_Ids_00021] Optional Data [Timestamp, Context Data Frame and Signature Frame are optional.]

5.1.4.1 Protocol Version and Header

Byte 0							
Bit 7	Bit 6	Bit 5	Bit 4	Bit 3	Bit 2	Bit 1	Bit 0
Protocol Version				Protocol Header			
				Re- served	Signa- ture	Times- tamp	Context Data

Table 5.1: Layout of Protocol Version and Header

5.1.4.1.1 Protocol Version

[PRS_Ids_00008] Version Information [The version information of the IDS protocol:

- Bit[7..4] : 0-15

Formula for calculation:

$\text{ProtocolVersion} = (\text{BYTE0} \& 0xF0) \gg 4$

With the extension of Context Data by introduction of the Context Data Version the protocol shall distinguish between Protocol Version:

Protocol Version : 1

Context Data is reported by the sensor without Context Data Version.

Protocol Version : 2

Context Data is reported by the sensor with Context Data Version.]

5.1.4.1.2 Protocol Header

[PRS_Ids_00009] Protocol Header Information [IDS protocol header information, includes configuration bits to switch specific functionalities on or off:

- Bit[0]: Context Data
 - 0: No Context Data Frame included
 - 1: Context Data Frame included
- Bit[1]: Timestamp
 - 0: No Timestamp included
 - 1: Timestamp included
- Bit[2]: Signature included
 - 0: No Signature Frame included

1: Signature Frame included

- Bit[3]: reserved

Formula for calculation:

$$\text{ProtocolHeader} = (\text{BYTE0} \& 0x0F)$$

Note:

[PRS_Ids_00010] Availability of optional data [Only if Timestamp, Context Data or Signature is available, the corresponding Protocol Header Bit is set to 1. Context Data or Signature will never be transmitted with Length=0.]

[PRS_Ids_00022] Protocol Header Bit Context Data Frame [If Protocol Header Bit[0] is set to 1, the IDS protocol shall consider Context Data Frame in the IDS frame for transmission. If Protocol Header Bit[0] is set to 0, no Context Data Frame shall be sent.]

[PRS_Ids_00023] Protocol Header Bit Timestamp [If Protocol Header Bit[1] is set to 1, the IDS protocol shall consider Timestamp in the IDS frame for transmission. If Protocol Header Bit[1] is set to 0, no Timestamp shall be sent.]

[PRS_Ids_00024] Protocol Header Bit Signature Frame [If Protocol Header Bit[2] is set to 1, the IDS protocol shall consider Signature Frame in the IDS frame for transmission. If Protocol Header Bit[2] is set to 0, no Signature Frame shall be sent.]

[PRS_Ids_00011] Preset Reserved Bits [Reserved Bits should be preset with value 0. On receiver side those bits should be ignored.]

5.1.4.2 IdsM Instance ID and Sensor Instance ID

Byte 1								Byte 2							
Bit	Bit	Bit	Bit	Bit	Bit	Bit	Bit	Bit	Bit	Bit	Bit	Bit	Bit	Bit	Bit
7	6	5	4	3	2	1	0	7	6	5	4	3	2	1	0
IDS Instance ID								Sensor Instance ID							

Table 5.2: IdsM Instance ID, Sensor Instance ID

The table shows the combined element IdsM and Sensor Instance ID

5.1.4.2.1 IdsM Instance ID

[PRS_Ids_00013] Instance ID [Unique identifier of the **IdsM** instance which sends the **security event**.

IdsM Instance ID range: 0-1023.

Usually there is one **IdsM** instance in one **ECU**. In case of complex **ECU** with Multi-Cores or Multi-Processor devices it is possible that there are multiple **IdsM**. In such constellation all **IdsM** must be configured with different IDS Instance ID.

Formula for calculation:

IdsM Instance ID (10 Bits) = ((BYTE2 & 0xC0) >> 6) | ((BYTE1 << 2))

5.1.4.2.2 Sensor Instance ID

[PRS_Ids_00014] Sensor Instance ID [Identifier to differentiate between multiple instances of same kind of sensor module.

Sensor Instance ID range: 0-63

e.g. Multiple CanDrv in one **ECU** can issue "same" **security event**. To differentiate these the Sensor Instance ID is used.

In case there is only one instance of the sensor in the configuration, the value of the Sensor Instance ID shall be, by default, set to 0.

Note:

The Sensor Instance ID shall be set at configuration of the corresponding instance.

Formula for calculation:

Sensor Instance ID (6 Bits) = (BYTE2 & 0x3F)

5.1.4.3 Event Definition ID

The Event Definition ID is shown in [Table 5.3](#).

Byte 3	Byte 4
Event Definition ID	

Table 5.3: Event Definition ID

[PRS_Ids_00015] Event Definition ID [The Event Definition ID is a unique identifier of a **security event**. It describes the kind of a **security event**.]

[PRS_Ids_00016] Event Instance [If a sensor generates multiple **security events** of same kind it is called Event instance.]

[PRS_Ids_00017] Event ID Range [The range for the Event Definition ID is split into three scopes:

1. AUTOSAR internal IDs: 0-0x7FFF (max. 32768 *security events*)
2. Customer specific IDs: 0x8000-0xFFFFE (max. 32767 *security events*)
3. Invalid ID: 0xFFFF

]

5.1.4.4 Count

Table 5.4 shows the IDS element Count.

Byte 5	Byte 6
Count	

Table 5.4: Count

[PRS_Ids_00018] Count [The count represents the number of *IdsM API* calls which result in the current *Qualified Security Event*. When an event is created, its count is initialized to 1. However, filters like Event Aggregation may combine several events into a single one. The count of this event is set to the sum of the counts of all aggregated events. If the *security event* is send by a smart sensor which already filters and preset the count value, this preset is just added to the count of *IdsM*. So the final count is the sum of the count of the sensor and the result of *IdsM* processing.]

5.1.4.5 Reserved

The Reserved byte is shown in [Table 5.5](#).

Byte 7
Reserved

Table 5.5: Reserved

[PRS_Ids_00019] Reserved Byte [The Byte[7] of the [Event Frame](#) of [IDS protocol](#) is reserved for future use.]

Note:

[PRS_Ids_00020] Preset Reserved Bytes [Reserved Bytes should be preset with value 0. On receiver side those bytes should be ignored.]

5.1.5 Timestamp

Details on timestamp are shown in [Figure 5.4](#).

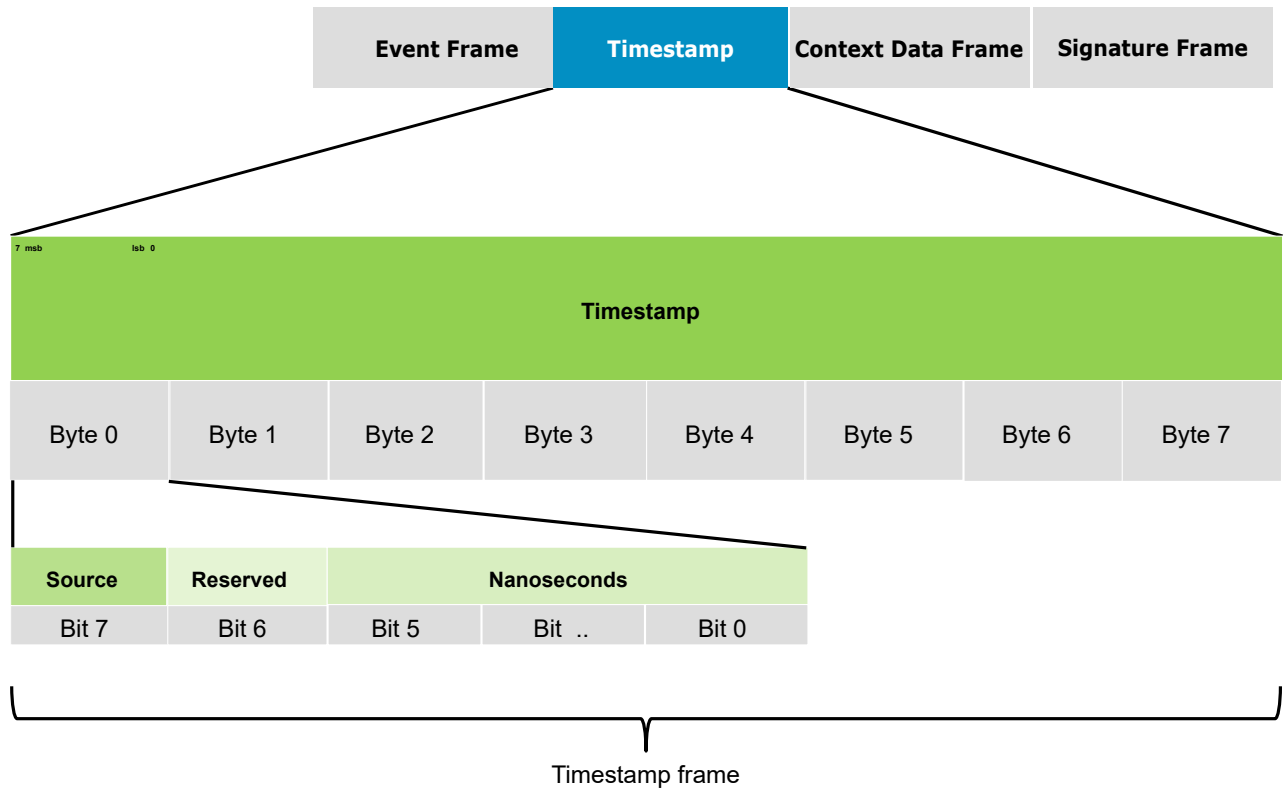

Figure 5.4: Timestamp

[PRS_Ids_00401] Timestamp Option

Upstream requirements: [RS_Ids_00502](#)

[The **IDS Protocol** provides Timestamp as a configurable option.]

[PRS_Ids_00402] Initial Value [Timestamp is logged when **security event** was detected the first time (first occurrence).]

[PRS_Ids_00403] Resolution [Resolution in **ms** is required. The Timestamp shall be encoded with 64 Bits in total to fit into a single CAN frame.]

[PRS_Ids_00404] Sources

Upstream requirements: [RS_Ids_00503](#)

[Different sources for Timestamp can be configured in the **IDS Protocol**.]

- Bit[7]: Timestamp source
0: AUTOSAR Standard CP: StbM - AP: ara::tsync

1: Auxiliary / OEM Specific timestamp

- Bit[6]: reserved

]

5.1.5.1 Timestamp AUTOSAR

Timestamp					
Byte 0			Byte 1	Byte 2	Byte 3
Bit 7	Bit 6	Bit 5 .. 0			
Source	Reserved	Nanoseconds			

Table 5.6: Timestamp Source and Nanoseconds

Timestamp			
Byte 4	Byte 5	Byte 6	Byte 7
Seconds			

Table 5.7: Timestamp Seconds

[PRS_Ids_00405] Format [For the [IDS Protocol](#) AUTOSAR time format combines the timestamps for nanoseconds with 30 Bits and seconds with 32 Bits.]

5.1.5.1.1 Nanoseconds

[PRS_Ids_00406] Nanoseconds Format [For nanoseconds only 30 Bits are required to encode 0..999 999 999 ns = 10^{-9} seconds.]

Note:

AUTOSAR Time Synchronisation Protocol (e.g. stbm in [CP](#)) uses 32 Bits for nanoseconds. The truncation of nanoseconds for [IDS Protocol](#) does not limit the resolution of the timestamp.

5.1.5.1.2 Seconds

[PRS_Ids_00407] Seconds Format [Seconds are encoded with 32 Bits which result in approximately 127 years resolution.]

Note:

For details please refer to Time Synchronisation Protocol SWS-TimeSynchronisation [\[2\]](#)

5.1.5.2 Timestamp OEM

Timestamp				
Byte 0		Byte 1	Byte 2	Byte 3
Bit 7	Bit 6 .. 0			
Source	OEM Timestamp			

Table 5.8: OEM Timestamp format

[PRS_Ids_00408] [OEM time source offers the option to use other time protocol. The length is limited to 63 Bits. An interface to OEM application is required. Accuracy is defined by OEM.]

5.1.6 Context Data

[PRS_Ids_00501] Context Data Option [The **IDS protocol** provides an optional feature to enrich the standard **security event** transferred in the **Event Frame** with more detailed information. Therefore context data can be added. It is a binary blob attached by the **sensor**. These data includes specific detailed information about the security event which can be used by the **SOC** for improved analysis of the security incident, e.g. a malformed message detected by a communication sensor.

IdSM has no knowledge of the content or structure of these data. Only the issuing **sensor** and the **Backend** or **SOC** knows it.]

5.1.6.1 Context Data Version

[PRS_Ids_00506] Context Data Version [The IDS Context Data Version shall represent the definition and structure of the **Context Data** of a **security event**. It shall have a length of 2 Bytes. Whenever the definition or the structure of the **Context Data** is changed the Context Data Version has to be increased.]

[PRS_Ids_00507] Context Data Modification [The most significant bit of the Context Data Version shall determine whether the **Context Data** has been modified using the ContextDataModifierCallout or not.

Byte[0] Bit [7]=0: Original reported Context Data

Byte[0] Bit [7]=1: Context Data provided by user callout]

There are two variants of context data with different sizes:

5.1.6.2 Context Data - Size Long

Figure 5.5 shows the "Context Data Size Long" with 4 Bytes length field.

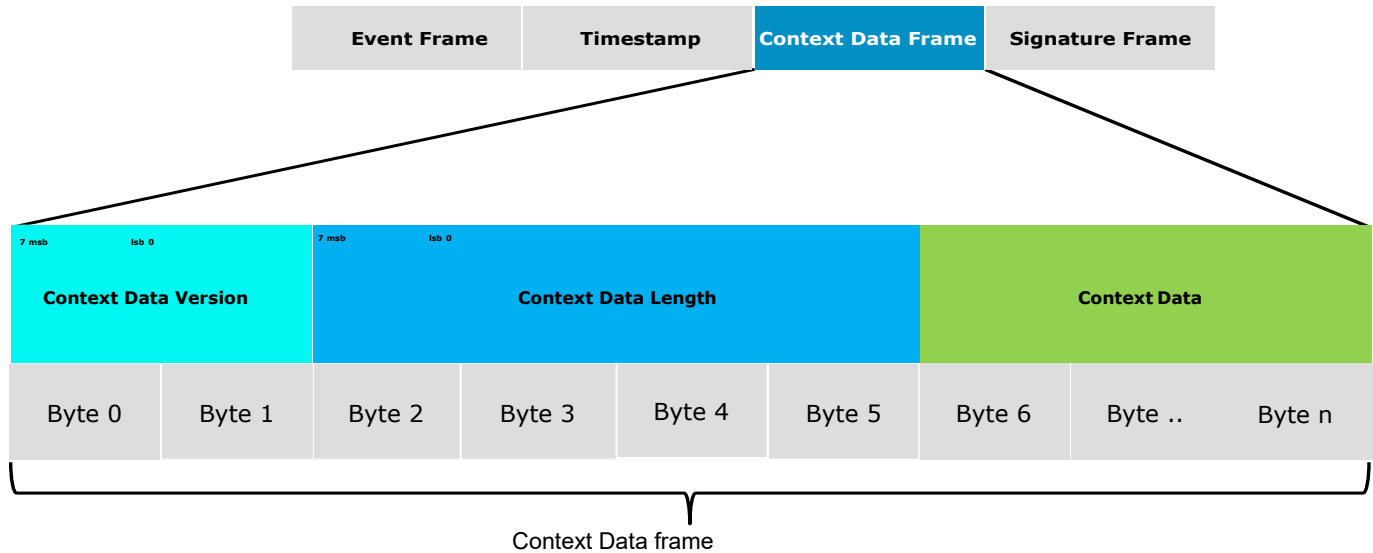

Figure 5.5: Context Data Size Long

[PRS_Ids_00502] Size Long [The "Context Data Size Long" includes a 4 Bytes length field. Up to $2^{31}-1$ context data bytes can be transmitted.]

5.1.6.3 Context Data - Size Short

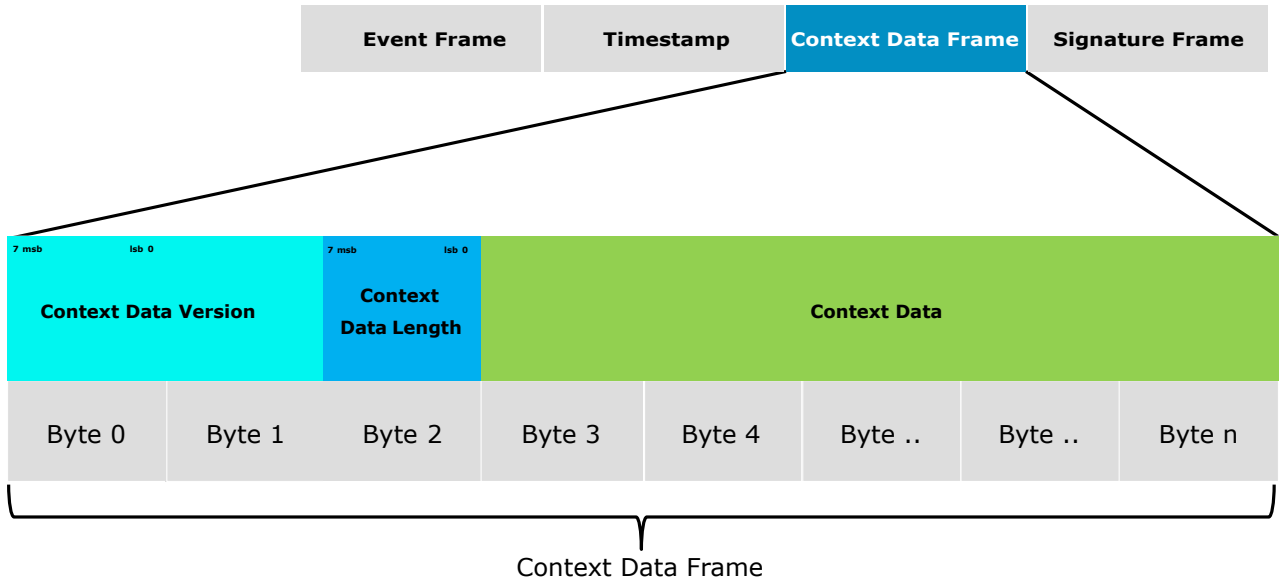

Figure 5.6: Context Data Size Short

[PRS_Ids_00503] Size Short [The "Context Data Size Short" is the alternative version with 1 Byte length field for max. 127 Bytes context data.]

5.1.7 Context Data Length Encoding

Context Data							
Byte 0							
Bit 7	Bit 6	Bit 5	Bit 4	Bit 3	Bit 2	Bit 1	Bit 0
Length Format	Context Data Length						

Table 5.9: Context Data Length Encoding

[PRS_Ids_00505] Length Format [Most Significant Bit (msb) of first byte Context Data (MSB) signals if the length is encoded in 7 Bits (1 Byte) or 31 Bits (4 Bytes).

Length Format=Context Data Byte[0] Bit[7]:

0: 7 Bits length information encoded in Context Data Byte[0] Bit[0..6]: 1-127 Bytes

1: 31 Bits Length Information encoded in Context Data Byte[0..3] Bit[0..30]: 1..(2³¹-1) Bytes]

5.1.8 Signature

[PRS_Ids_00601] Signature Option

Upstream requirements: [RS_Ids_00505](#)

[The **IDS protocol** provides an optional feature to make the transmission of **QSEv** more secure. A digital signature can be added to the **IDS message**. It can be used to ensure authenticity as well as to prove integrity of signed messages from the **IdsM** via all communication systems until reaching the **Backend** or **SOC** (End2End-Security).]

Figure 5.7 shows the signature option of the **IDS protocol**.

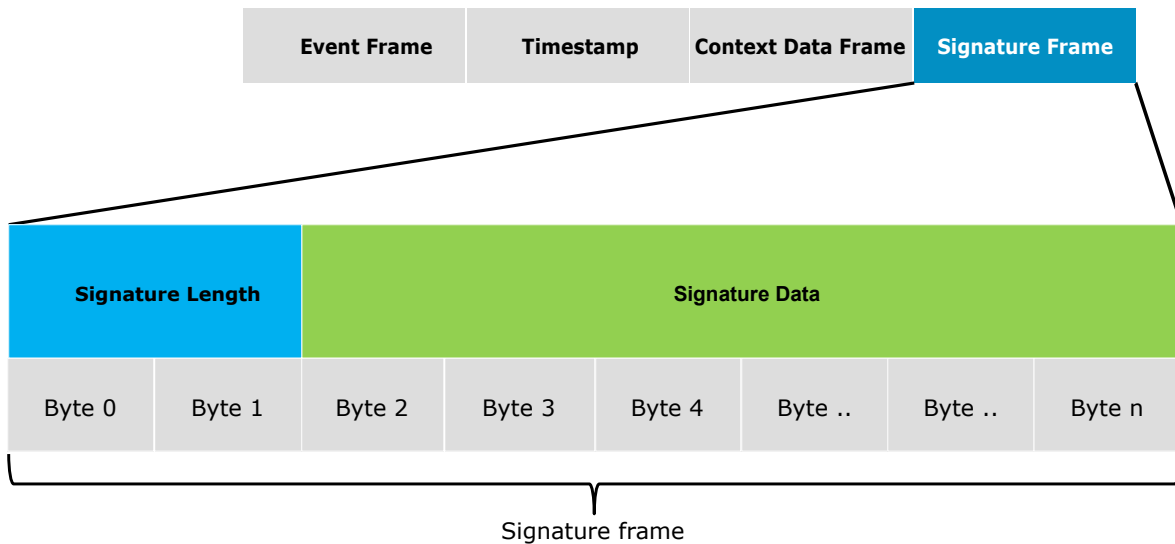

Figure 5.7: Signature

5.1.8.1 Signature Length

[PRS_Ids_00602] Length [

- Signature Length is encoded in 2 Bytes:
Signature Length Byte[0..1]: Signature Length 1..65535

]

5.1.8.2 Signature Data

Signature							
Byte 2	Byte 3	Byte 4	Byte 5	Byte 5	Byte ..	Byte ..	Byte n
Signature Data							

Table 5.10: Signature

Table 5.10 shows the signature data.

[PRS_Ids_00603] Format [Signature Data Byte[2..65537]: Signature data

The cryptographic value of the Signature of **security event** is calculated with the serialized data of:

Event Frame + optional Timestamp + optional Context Data.

Which kind of cryptoalgorithm is used, depends on the system.

The **IDS protocol** does not prescribe any specific algorithm nor the format.]

(also refer to [5.1.4](#) Event Frame, [5.1.5](#) Timestamp and [5.1.6](#) Context Data.)

5.1.9 IDS Message Separation

[PRS_Ids_00800] IDS Message Separation Header [On ethernet the IDS Message Separation Header is mandatory. It is used to address **IDS messages** unambiguously. In addition to the transmission of a single **IDS message** via ethernet, multiple **IDS messages** can be collected and sent within a single ethernet frame.]

[PRS_Ids_00801] Ethernet Port Address [An unique ethernet port address should be used for **IDS** communication.]

[PRS_Ids_00802] SOME/IP [**SOME/IP** and **IDS** messages should not be mixed on same port as they can't be distinguished properly by the receiver.]

Note:

The **IdsR** typically is connected via Ethernet. But as already mentioned also other automotive communication buses and protocols are supported. Regarding message separation header the following should be considered:

- **CAN FD**: The I-Pdu-Multiplexer [3] supports collecting of multiple **IDS messages** within one message. Because of the size restrictions on **CAN** the I-Pdu-Multiplexer typically uses short header or no header option. Therefore the IDS Message Separation Header is normally not used on **CAN** buses.
- **FlexRay**: The PDU Packing feature supports collecting of multiple **IDS messages** within one message. It does not use separation headers but update bits to identify available parts.
For more details please refer to SWS FlexRay Interface [4].
- **CAN** (Standard): **IDS frame** is transferred without IDS Message Separation Header.
- **LIN**: **IDS frame** is transferred without IDS Message Separation Header.

5.1.9.1 IDS Message Separation Header

Figure 5.8 shows the IDS Message Separation Header.

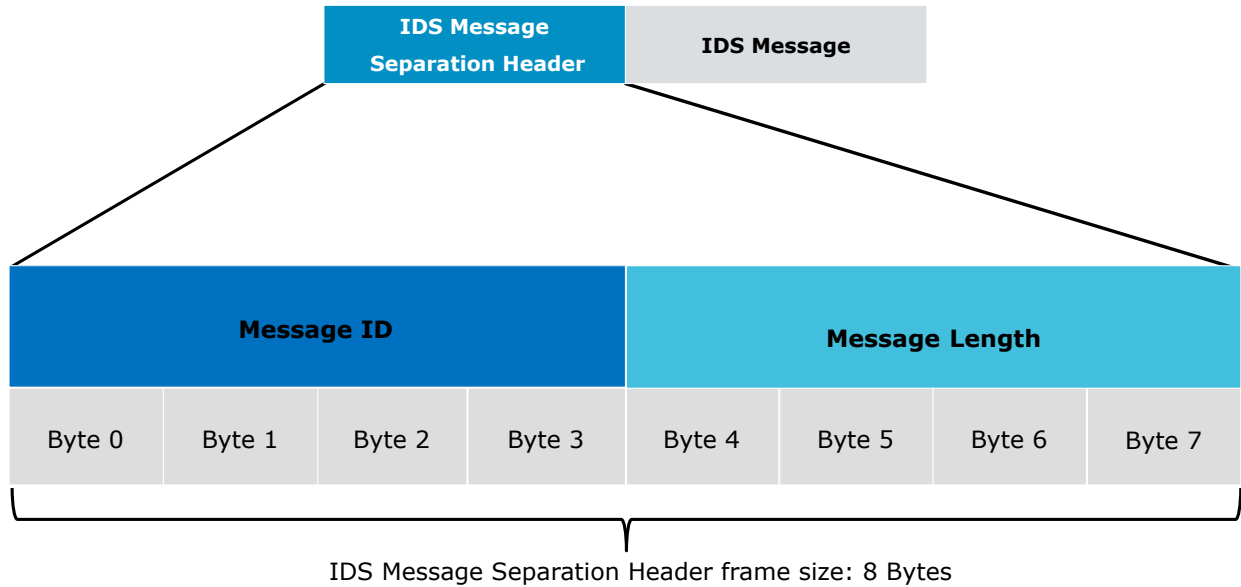

Figure 5.8: IDS Message Separation Header

[PRS_Ids_00803] Format [

The IDS Message Separation Header consists of a 4 byte **ID** field for unique identification at the receiver and a 4 byte length field specifying the data length. Both in big endian byte order.]

5.1.9.2 IDS Message Separation Header ID

[PRS_Ids_00804] ID [The IDS Message Separation Header ID is encoded in 4 byte. It is an arbitrary number, preferable 0.]

Note:

In AUTOSAR **CP** the IDS Message Separation Header ID shall be set at configuration of the Socket Adapter and I-PDU Multiplexer.

For details please refer to SWS-Socket Adaptor [5] and SWS-IPDUMultiplexer [3].

5.1.9.3 IDS Message Separation Header Length

[PRS_Ids_00805] Length [The IDS Message Separation Header Length is equal to the IDS Message length. It is encoded in 4 bytes.

The possible range is:

Message Length Byte[0..3]: 8.. 2.147.549.212 Bytes.]

The minimum length is 8 Bytes and is equal to the minimal **IDS message** which is the **Event Frame** (8 Bytes) without any options configured.

Please also refer to [5.1.11.2 Example IDS Message with Minimum Size](#).

The maximum length depends on the configured options.

In case all options are configured with maximum size and the IDS Message Separation Header is used the total size message is 2.147.549.212 Bytes.

For details please refer to [5.1.11.1 Example IDS Message with Maximum Size](#).

Note:

AUTOSAR platforms:

- **CP**: The IDS Message Separation Header corresponds to the **N-PDU** mechanism which is supported by SocketAdaptor/I-PDU-Multiplexer [5] / [3].
- **AP**: The IDS Message Separation Header must be generated by **IdSM**.

5.1.10 PDU Type

Note:

In the **CP IDS protocol** uses **GeneralPurposeIPdu** (Interaction Layer Protocol Data Unit) of type **IDS** for transmission of Qualified Security Event **QSEv**.

For details refer to System Template [6], Chapter Communication.

5.1.11 Example of IDS Messages

5.1.11.1 Example IDS Message with Maximum Size

[PRS_Ids_00900] Maximum IDS Message [All options of IDS protocol configured with maximum size:

- Option Timestamp AUTOSAR is configured.
- Option Context Data Size Long is configured.
- Option Signature is configured.

Event Frame: 8 Bytes
Timestamp: 8 Bytes
Context Data Size Long: $2^{31}-1$ Bytes = 2.147.483.647 Bytes
Context Data Size Long Length Encoding: 4 Bytes
Signature: 65535 Bytes
Signature Length Encoding: 2 Bytes
IDS Message = $8 + 8 + 2.147.483.647 + 4 + 65535 + 2 = 2.147.549.204$ Bytes

For CAN Bus:
Maximum message size with CAN TP = $2^{32} - 1 = 4.294.967.295$

For Ethernet:
IDS Message Separation Header must be added with 8 Bytes:
**Maximum IDS Message with IDS Separation Header:
 $8 \text{ Bytes} + 2.147.549.204 \text{ Bytes} = 2.147.549.212 \text{ Bytes}$**

Maximum Size which can be encoded with 4 Bytes for IDS Message Separation Header:
 $4 \text{ Bytes} = 2^{32} = 4.294.967.296$

This ensures that IDS messages with maximum size can be transferred via the standard automotive bus system!]

5.1.11.2 Example IDS Message with minimum size

[PRS_Ids_00901] Minimum IDS Message [No option of IDS protocol is configured - minimal size:

Event Frame: 8 Bytes
IDS Message = 8 Bytes]

5.2 Message types

Currently not used for **IDS Protocol**.

5.3 Services / Commands

Currently not used for [IDS Protocol](#).

5.4 Sequences (lower layer)

Currently not used for [IDS Protocol](#).

5.5 Error messages

[IDS Protocol](#) does not send specific error messages.

6 Configuration parameters

Currently not used for [IDS Protocol](#).

7 Protocol usage and guidelines

Currently not used for [IDS Protocol](#).

A Change history of AUTOSAR traceable items

Please note that the lists in this chapter also include traceable items that have been removed from the specification in a later version. These items do not appear as hyperlinks in the document.

A.1 Traceable item history of this document according to AUTOSAR Release R24-11

A.1.1 Added Specification Items in R24-11

Number	Heading
[PRS_Ids_00022]	Protocol Header Bit Context Data Frame
[PRS_Ids_00023]	Protocol Header Bit Timestamp
[PRS_Ids_00024]	Protocol Header Bit Signature Frame
[PRS_Ids_00506]	Context Data Version
[PRS_Ids_00507]	Context Data Modification

Table A.1: Added Specification Items in R24-11

A.1.2 Changed Specification Items in R24-11

Number	Heading
[PRS_Ids_00008]	Version Information

Table A.2: Changed Specification Items in R24-11

A.1.3 Deleted Specification Items in R24-11

Number	Heading
[PRS_Ids_00012]	
[PRS_Ids_00504]	

Table A.3: Deleted Specification Items in R24-11

- [1] Requirements on Intrusion Detection System
AUTOSAR_FO_RS_IntrusionDetectionSystem
- [2] Specification of Time Synchronization
AUTOSAR_AP_SWS_TimeSynchronization
- [3] Specification of I-PDU Multiplexer
AUTOSAR_CP_SWS_IPDUMultiplexer
- [4] Specification of FlexRay Interface
AUTOSAR_CP_SWS_FlexRayInterface
- [5] Specification of Socket Adaptor
AUTOSAR_CP_SWS_SocketAdaptor
- [6] System Template
AUTOSAR_CP_TPS_SystemTemplate