

<b>Document Title</b>	Requirements on I-PDU Multiplexer
<b>Document Owner</b>	AUTOSAR GbR
<b>Document Responsibility</b>	AUTOSAR GbR
<b>Document Version</b>	1.0.2
<b>Document Status</b>	Final
<b>Part of Release</b>	2.1
<b>Revision</b>	0014

<b>Document Change History</b>			
<b>Date</b>	<b>Version</b>	<b>Changed by</b>	<b>Change Description</b>
24.01.2007	1.0.2	AUTOSAR Administration	<ul style="list-style-type: none"><li>• “Advice for users” revised</li><li>• “Revision Information” added</li></ul>
28.11.2006	1.0.1	AUTOSAR Administration	Legal disclaimer revised
10.05.2006	1.0.0	AUTOSAR Administration	Initial release

Page left intentionally blank

## Disclaimer

**Any use** of these specifications requires membership within the AUTOSAR Development Partnership or an agreement with the AUTOSAR Development Partnership. The AUTOSAR Development Partnership will not be liable for any use of these specifications.

Following the completion of the development of the AUTOSAR specifications commercial exploitation licenses will be made available to end users by way of written License Agreement only.

No part of this publication may be reproduced or utilized in any form or by any means, electronic or mechanical, including photocopying and microfilm, without permission in writing from the publisher.

The word AUTOSAR and the AUTOSAR logo are registered trademarks.

Copyright © 2004-2006 AUTOSAR Development Partnership. All rights reserved.

## **Advice to users of AUTOSAR Specification Documents:**

AUTOSAR Specification Documents may contain exemplary items (exemplary reference models, "use cases", and/or references to exemplary technical solutions, devices, processes or software).

Any such exemplary items are contained in the Specification Documents for illustration purposes only, and they themselves are not part of the AUTOSAR Standard. Neither their presence in such Specification Documents, nor any later documentation of AUTOSAR conformance of products actually implementing such exemplary items, imply that intellectual property rights covering such exemplary items are licensed under the same rules as applicable to the AUTOSAR Standard.

## Table of Contents

1	Scope of this document .....	5
2	How to read this document.....	6
2.1	Conventions used.....	6
2.2	Requirement structure.....	7
3	Acronyms and abbreviations .....	8
4	Requirements Specification AUTOSAR IPduM .....	9
4.1	Functional Overview.....	9
4.2	Functional Requirements .....	10
4.2.1	Configuration.....	10
4.2.1.1	[BSW02800] Exactly one selector field per PDU.....	10
4.2.1.2	[BSW02801] Size of the selector field.....	10
4.2.1.3	[BSW02802] Position of the selector field .....	10
4.2.1.4	[BSW02815] Compile Time configuration of the selector field .....	11
4.2.1.5	[BSW02803] Unused values of the selector field .....	11
4.2.1.6	[BSW02804] Support for static and dynamic parts of the I-PDU ...	11
4.2.1.7	[BSW02808] Support of multiplexed I-PDUs with a static part of length “zero”.....	12
4.2.2	Initialization .....	12
4.2.2.1	[BSW02809] Initialization of multiplexed I-PDUs.....	12
4.2.3	Normal Operation.....	12
4.2.3.1	[BSW02806] Semantic of the multiplexer.....	12
4.2.3.2	[BSW02816] Combining of multiplexed I-PDUs on sender side....	13
4.2.3.3	[BSW02819] No queuing of transmission requests on sender side .....	14
4.2.3.4	[BSW02811] Triggering condition on sender side .....	14
4.2.3.5	[BSW02817] De-multiplexing I-PDUs on receiver side .....	14
4.2.3.6	[BSW02818] Confirmation replication of multiplexed I-PDUs.....	15
4.2.3.7	[BSW02814] Confirmation depends upon selector field.....	15
4.2.4	Shutdown Operation .....	16
4.2.5	Fault Operation .....	16
4.3	Non-Functional Requirements (Qualities) .....	16
4.3.1	Timing Requirements / Resource Usage .....	16
4.3.1.1	[BSW02807] No Runtime Overhead for systems without I-PDU multiplexing.....	16
4.4	Requirements to other modules .....	16
4.4.1	Configuration of PduR.....	16
4.4.1.1	[BSW02810] Routing of multiplexed I-PDUs on sender side.....	16
4.4.1.2	[BSW02813] Routing of Send Confirmations .....	17
4.4.1.3	[BSW02812] Routing of multiplexed I-PDUs on receiver side.....	17
5	References .....	18
5.1	Deliverables of AUTOSAR .....	18

## 1 Scope of this document

The goal of this document is to define the functional and non-functional requirements on the AUTOSAR I-PDU-Multiplexer module (IPduM).

## 2 How to read this document

Each requirement has its unique identifier starting with a to be defined prefix (default is "REQ", but please change that to enable a unique requirements ID calculation). For any review annotations, remarks and/or questions please refer to this unique ID rather than chapter or page numbers!

### 2.1 Conventions used

In requirements, the following specific semantics shall be used (based on the Internet Engineering Task Force IETF).

The key words "MUST", "MUST NOT", "REQUIRED", "SHALL", "SHALL NOT", "SHOULD", "SHOULD NOT", "RECOMMENDED", "MAY", and "OPTIONAL" in this document are to be interpreted as:

- **SHALL:** This word means that the definition is an absolute requirement of the specification.
- **SHALL NOT:** This phrase means that the definition is an absolute prohibition of the specification.
- **MUST:** This word means that the definition is an absolute requirement of the Conventions specification due to legal issues.
- **MUST NOT:** This phrase means that the definition is an absolute prohibition of the specification due to legal constraints.
- **SHOULD:** This word, or the adjective "RECOMMENDED", mean that there may exist valid reasons in particular circumstances to ignore a particular item, but the full implications must be understood and carefully weighed before choosing a different course.
- **SHOULD NOT:** This phrase, or the phrase "NOT RECOMMENDED" mean that there may exist valid reasons in particular circumstances when the particular behavior is acceptable or even useful, but the full implications should be understood and the case carefully weighed before implementing any behavior described with this label.
- **MAY:** This word, or the adjective „OPTIONAL“, means that an item is truly optional. One vendor may choose to include the item because a particular marketplace requires it or because the vendor feels that it enhances the product while another vendor may omit the same item. An implementation, which does not include a particular option, **MUST** be prepared to interoperate with another implementation, which does include the option, though perhaps with reduced functionality. In the same vein an implementation, which does include a particular option, **MUST** be prepared to interoperate with another implementation, which does not include the option (except, of course, for the feature the option provides).

## 2.2 Requirement structure

Each module specific chapter contains a short functional description of the Basic Software Module. Requirements of the same kind within each chapter are grouped under the following headlines (where applicable):

Functional Requirements:

- Configuration (which elements of the module need to be configurable)
- Initialisation
- Normal Operation
- Shutdown Operation
- Fault Operation
- ...

Non-Functional Requirements:

- Timing Requirements
- Resource Usage
- Usability
- Output for other WPs (e.g. Description Templates, Tooling,...)
- ...

### 3 Acronyms and abbreviations

These are definitions made by AUTOSAR IPduM.

<b>Acronym:</b>	<b>Description:</b>
multiplexed I-PDU	I-PDU multiplexing means using the same PCI of an I-PDU with more than one unique layout of its SDU. A selector field is a part of the SDU of the multiplexed I-PDU. It is used to distinguish the different layouts of the multiplexed I-PDUs from each other
selector field	The selector field is part of a multiplexed I-PDU. It consists of contiguous bits. The value of the selector field selects the layout of the multiplexed part of the I-PDU.
static part	Some parts/signals of the I-PDU may be the same regardless of the selector field. Such a part is called <i>static part</i> . The static part must not necessarily be contiguous.
dynamic part	According to the value of the selector field some parts of the I-PDU have a different layout. These parts of the I-PDU that can contain different signals are called <i>dynamic part</i> . The dynamic part must not necessarily be contiguous.
PCI	“Protocol Control Information” A description can be found on page 04-51 ff of DOC_LAYERD_ARCH.
PDU	“Protocol Data Unit” A description can be found on page 04-51 ff of DOC_LAYERD_ARCH.
PduR	Module that transfers I-PDUs from one module to another module. The I-PDU Router can be utilized for gateway operations and for internal routing purposes.
SDU	“Service Data Unit” A description can be found in chapter 4 of DOC_LAYERD_ARCH.



## 4 Requirements Specification AUTOSAR IPduM

### 4.1 Functional Overview

The AUTOSAR IPduM is placed next to the PduR-Module within the AUTOSAR layered architecture.

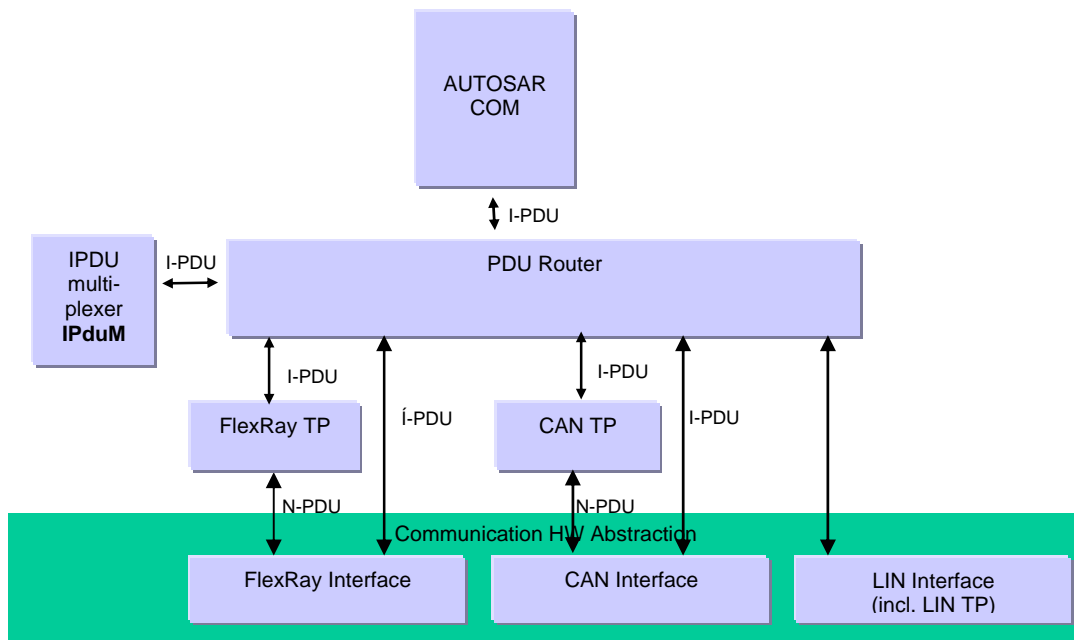

**Figure 1: Placement of the IPduM in the AUTOSAR layered architecture.**

I-PDU multiplexing means using the same PCI of an I-PDU with more than one unique layout of its SDU. A selector field is a part of the SDU of the multiplexed I-PDU. It is used to distinguish the different layouts of the multiplexed I-PDUs from each other.

Multiplexing of I-PDUs is currently known from CAN, but is not restricted to this communication system.

The I-PDU Multiplexer Module is responsible to combine appropriate I-PDUs received from COM via IPDU-router to new, multiplexed I-PDUs sent back to the I-PDU Router on sender-side. On receiver-side it is responsible to interpret the content of multiplexed I-PDUs and provide COM via IPDU-router with its appropriate separated I-PDUs by taking into account the value of the selector field.

## 4.2 Functional Requirements

### 4.2.1 Configuration

#### 4.2.1.1 [BSW02800] Exactly one selector field per PDU

<b>Initiator:</b>	Volkswagen / BMW
<b>Date:</b>	27.06.2005
<b>Short Description:</b>	Exactly one selector field per I-PDU shall be allowed
<b>Type:</b>	New
<b>Importance:</b>	Medium
<b>Description:</b>	For a multiplexed I-PDU there shall be exactly one selector field.
<b>Rationale:</b>	reduce complexity
<b>Use Case:</b>	--
<b>Dependencies:</b>	--
<b>Conflicts:</b>	--
<b>Supporting Material:</b>	--

#### 4.2.1.2 [BSW02801] Size of the selector field

<b>Initiator:</b>	Volkswagen / BMW
<b>Date:</b>	27.06.2005
<b>Short Description:</b>	The size of the selector field shall be configurable between one bit and eight bits.
<b>Type:</b>	New
<b>Importance:</b>	High
<b>Description:</b>	The size in bits of the selector field shall be configurable in a range of one bit and eight bits.
<b>Rationale:</b>	The size of the selector field should be according to the number of different states of the multiplexer required. Typically a four-bit selector field is sufficient.
<b>Use Case:</b>	A four-way multiplexing requires two bits
<b>Dependencies:</b>	<a href="#">BSW02803</a>
<b>Conflicts:</b>	--
<b>Supporting Material:</b>	--

#### 4.2.1.3 [BSW02802] Position of the selector field

<b>Initiator:</b>	Volkswagen / BMW
<b>Date:</b>	27.06.2005
<b>Short Description:</b>	The position of the selector field within the PDU shall be configurable.
<b>Type:</b>	New
<b>Importance:</b>	High
<b>Description:</b>	The position of the selector field within the PDU shall be configurable. The configuration shall follow the following rules: <ul style="list-style-type: none"> <li>contiguous bits,</li> <li>static size,</li> <li>no overlapping of byte boundaries.</li> </ul>
<b>Rationale:</b>	Downwards compatibility. Do not change layout of static signals when turning an I-PDU into a multiplexed I-PDU.
<b>Use Case:</b>	Some CAN messages became multiplexed messages because the space was not sufficient for a new signal anymore. The selector field was placed somewhere in the PDU without moving the 'old' signals.

<b>Dependencies:</b>	--
<b>Conflicts:</b>	--
<b>Supporting Material:</b>	--

#### 4.2.1.4 [BSW02815] Compile Time configuration of the selector field

<b>Initiator:</b>	Volkswagen / BMW
<b>Date:</b>	04.11.2005
<b>Short Description:</b>	Compile-time configuration of selector field.
<b>Type:</b>	New
<b>Importance:</b>	High
<b>Description:</b>	The position and the size shall be configurable at compile time.
<b>Rationale:</b>	Minimize configuration overhead by requiring only compile time configuration
<b>Use Case:</b>	--
<b>Dependencies:</b>	BSW02801, BSW02802
<b>Conflicts:</b>	--
<b>Supporting Material:</b>	--

#### 4.2.1.5 [BSW02803] Unused values of the selector field

<b>Initiator:</b>	Volkswagen / BMW
<b>Date:</b>	27.06.2005
<b>Short Description:</b>	It shall be possible that not all possible values of the selector field are used.
<b>Type:</b>	New
<b>Importance:</b>	High
<b>Description:</b>	The number of possible multiplexed SDUs within a I-PDU is $2^n$ , where n is the size in bits of the selector field. In some cases not all possible selector field values are needed and it shall be possible not to assign a SDU layout to these unused selector field values.
<b>Rationale:</b>	<ol style="list-style-type: none"> <li>1) Usage of an arbitrary number of multiplexed layouts that is not necessarily a power of 2.</li> <li>2) To specify the selector field with some reserved values to allow an extension of the multiplexed layouts in the future maintaining backwards compatibility.</li> </ol>
<b>Use Case:</b>	If three different I-PDU layouts are needed at least a two bit selector field has to be spent (four-way multiplexer)
<b>Dependencies:</b>	--
<b>Conflicts:</b>	--
<b>Supporting Material:</b>	--

#### 4.2.1.6 [BSW02804] Support for static and dynamic parts of the I-PDU

<b>Initiator:</b>	Volkswagen / BMW
<b>Date:</b>	27.06.2005
<b>Short Description:</b>	It shall be configurable that the selector field multiplexes only parts of the I-PDU.
<b>Type:</b>	New
<b>Importance:</b>	High
<b>Description:</b>	For each used selector field value a dynamic layout shall be configurable. The static part shall be configurable per I-PDU.
<b>Rationale:</b>	If a selector field is introduced to a PDU this allows to leave not-multiplexed signals unchanged (downward compatibility).
<b>Use Case:</b>	A selector field is attached to a PDU which is currently not multiplexed. The

	layout of some of the 'old' signals should not be changed
<b>Dependencies:</b>	<a href="#">BSW02808</a>
<b>Conflicts:</b>	--
<b>Supporting Material:</b>	--

#### 4.2.1.7 [BSW02808] Support of multiplexed I-PDUs with a static part of length "zero"

<b>Initiator:</b>	Volkswagen / BMW
<b>Date:</b>	12.10.2005
<b>Short Description:</b>	It shall be possible that the static part of a I-PDU is zero bits long.
<b>Type:</b>	New
<b>Importance:</b>	High
<b>Description:</b>	s. above
<b>Rationale:</b>	It should be possible to multiplex the whole I-PDU.
<b>Use Case:</b>	BMW service messages do not use a static part
<b>Dependencies:</b>	<a href="#">BSW02804</a>
<b>Conflicts:</b>	--
<b>Supporting Material:</b>	--

### 4.2.2 Initialization

#### 4.2.2.1 [BSW02809] Initialization of multiplexed I-PDUs

<b>Initiator:</b>	Volkswagen / BMW
<b>Date:</b>	14.10.2005
<b>Short Description:</b>	Initialization data of multiplexed I-PDUs shall be derived from the COM init-values
<b>Type:</b>	New
<b>Importance:</b>	High
<b>Description:</b>	The initial values of the static part shall be derived from the COM configuration. The initial value of the dynamic part shall be derived from the COM configuration regarding the initial value of the selector field.
<b>Rationale:</b>	Reuse of existing COM functionality
<b>Use Case:</b>	--
<b>Dependencies:</b>	--
<b>Conflicts:</b>	--
<b>Supporting Material:</b>	--

Note:

The selector field is initialized like a normal COM signal within the dynamic part.

### 4.2.3 Normal Operation

#### 4.2.3.1 [BSW02806] Semantic of the multiplexer

<b>Initiator:</b>	Volkswagen / BMW
<b>Date:</b>	22.09.05
<b>Short Description:</b>	The multiplexer module shall interpret and fill the content of the dynamic part of the I-PDU according to the value of the selector field.
<b>Type:</b>	New

<b>Importance:</b>	High																																						
<b>Description:</b>	<p>Each multiplexed I-PDU consists of three different parts. These parts must not necessarily be contiguous.</p> <ol style="list-style-type: none"> <li>1. selector field</li> <li>2. dynamic part</li> <li>3. static part (optional, see <a href="#">BSW02808</a>)</li> </ol> <p>For signals within these parts the normal signal placing rules apply, as defined in <b>DOC_SWS_COM</b>.</p>																																						
<b>Rationale:</b>	Backwards compatibility to current solutions.																																						
<b>Use Case:</b>	<p>This behaviour is currently used in Volkswagen ECUs.</p> <p>Example:</p> <p style="text-align: center;">S1            SF      D1          S2          D2          S3</p> <ul style="list-style-type: none"> <li>• SF is the selector field</li> <li>• The dynamic part consists of two subparts D1 and D2 D1 and D2 contain different signals according to the selector field value (see next table)</li> <li>• The static part consists of three subparts S1, S2 and S3. S1, S2 and S3 contain signals which are not multiplexed</li> </ul> <p>For each dynamic subpart a different signal layout may be configured. Then different signals shall be sent out according to the selector field value.</p> <p>Example (m1, m2, ... is a signal within the dynamic part of a I-PDU):</p> <table style="margin-left: auto; margin-right: auto;"> <thead> <tr> <th style="text-align: left;">selector field value</th> <th colspan="2"></th> <th colspan="2"></th> <th colspan="2">D1 -layout</th> <th colspan="2">D2 layout</th> </tr> </thead> <tbody> <tr> <td>0</td> <td>m1</td> <td>M2</td> <td>m3</td> <td>m4</td> <td>m5</td> <td>m6</td> <td colspan="2">m7</td> </tr> <tr> <td>1</td> <td colspan="2">m8</td> <td colspan="2">m9</td> <td>m10</td> <td>m11</td> <td>m12</td> <td>m13</td> <td>m14</td> </tr> <tr> <td>2</td> <td colspan="2">m15</td> <td colspan="2"></td> <td></td> <td>m16</td> <td colspan="2">m17</td> <td>m18</td> </tr> </tbody> </table> <p>All individual signals of the multiplexed I-PDUs shall be sent and received like non multiplexed COM signals.</p>	selector field value					D1 -layout		D2 layout		0	m1	M2	m3	m4	m5	m6	m7		1	m8		m9		m10	m11	m12	m13	m14	2	m15					m16	m17		m18
selector field value					D1 -layout		D2 layout																																
0	m1	M2	m3	m4	m5	m6	m7																																
1	m8		m9		m10	m11	m12	m13	m14																														
2	m15					m16	m17		m18																														
<b>Dependencies:</b>	<a href="#">BSW02804</a>																																						
<b>Conflicts:</b>	--																																						
<b>Supporting Material:</b>	--																																						

#### 4.2.3.2 [BSW02816] Combining of multiplexed I-PDUs on sender side

<b>Initiator:</b>	Volkswagen / BMW
<b>Date:</b>	04.11.2005
<b>Short Description:</b>	Combining of multiplexed I-PDUs on sender side
<b>Type:</b>	New
<b>Importance:</b>	High
<b>Description:</b>	<p>On sender side the IPduM combines the static and the appropriate dynamic part within IPduM after receiving the I-PDUs from the PduR. When the configured triggering condition (see <a href="#">BSW02811</a>) is fulfilled the multiplexed I-PDU is sent to the lower layer via the PduR.</p>
<b>Rationale:</b>	<p>Having a static and a dynamic part. Implementation of I-PDU multiplexing next to PduR.</p>
<b>Use Case:</b>	--
<b>Dependencies:</b>	<a href="#">BSW02811</a> , <a href="#">BSW02814</a> , <a href="#">BSW02810</a>
<b>Conflicts:</b>	--
<b>Supporting Material:</b>	--

#### 4.2.3.3 [BSW02819] No queuing of transmission requests on sender side

<b>Initiator:</b>	Volkswagen / BMW
<b>Date:</b>	21.11.2005
<b>Short Description:</b>	No queuing of transmission requests on sender side
<b>Type:</b>	New
<b>Importance:</b>	High
<b>Description:</b>	Unless a transmission request for an I-PDU of the IPduM is either a) confirmed by the underlying layer b) has got an internal timeout every other transmission request to the same I-PDU shall result in an error. The internal timeout shall be configurable per I-PDU.
<b>Rationale:</b>	Avoid IPduM internal queuing of transmission requests
<b>Use Case:</b>	--
<b>Dependencies:</b>	<a href="#">BSW02816</a>
<b>Conflicts:</b>	--
<b>Supporting Material:</b>	--

#### 4.2.3.4 [BSW02811] Triggering condition on sender side

<b>Initiator:</b>	Volkswagen / BMW
<b>Date:</b>	14.10.2005
<b>Short Description:</b>	Triggering of sending multiplexed I-PDUs
<b>Type:</b>	New
<b>Importance:</b>	High
<b>Description:</b>	On sender side the IPduM combines the dynamic and static part after receiving them from COM. There shall be three different triggering conditions configurable that define when the combined multiplexed I-PDUs are sent to the lower layer (via the PduR). <ul style="list-style-type: none"> <li>SEND_ON_STATIC – the I-PDU will be sent after receiving a new static part</li> <li>SEND_ON_DYNAMIC – the I-PDU will be sent after receiving a new dynamic part</li> <li>SEND_ALWAYS – the I-PDU will be sent always after receiving a new static or new dynamic part</li> </ul>
<b>Rationale:</b>	Implementation of I-PDU multiplexing in an own module next to PduR.
<b>Use Case:</b>	--
<b>Dependencies:</b>	<a href="#">BSW02810</a>
<b>Conflicts:</b>	--
<b>Supporting Material:</b>	--

Note:

COM knows only about the dynamic and static part as (source) I-PDUs and not about the combined multiplexed I-PDU. COM can only guarantee the minimum temporal distance of the source I-PDUs. Therefore the minimum temporal distance for the multiplexed IPDU might be violated, for example if two different dynamic source I-PDUs are sent, having SEND\_ON\_DYNAMIC mode configured.

#### 4.2.3.5 [BSW02817] De-multiplexing I-PDUs on receiver side

<b>Initiator:</b>	Volkswagen / BMW
<b>Date:</b>	04.11.2005

<b>Short Description:</b>	Routing of multiplexed I-PDUs on receiver side
<b>Type:</b>	New
<b>Importance:</b>	High
<b>Description:</b>	On receiver side the IPduM extracts the static and dynamic parts of the multiplexed I-PDU received from the PduR and sends them to COM as standard IPDUs via the PduR. In an optimization implementation it shall be allowed to send the I-PDU directly to COM.
<b>Rationale:</b>	Having a static and a dynamic part. Implementation of I-PDU multiplexing next to PduR.
<b>Use Case:</b>	--
<b>Dependencies:</b>	--
<b>Conflicts:</b>	--
<b>Supporting Material:</b>	--

#### 4.2.3.6 [BSW02818] Confirmation replication of multiplexed I-PDUs

<b>Initiator:</b>	Volkswagen / BMW
<b>Date:</b>	04.11.2005
<b>Short Description:</b>	Confirmation replication of multiplexed I-PDUs
<b>Type:</b>	New
<b>Importance:</b>	High
<b>Description:</b>	After receiving send confirmations from the PduR the IPduM confirms to COM the static part of the multiplexed I-PDU and the dynamic part according to value of the selector field.
<b>Rationale:</b>	Having a static and a dynamic part. Implementation of I-PDU multiplexing next to PduR.
<b>Use Case:</b>	--
<b>Dependencies:</b>	<a href="#">BSW02813</a> , <a href="#">BSW02814</a>
<b>Conflicts:</b>	--
<b>Supporting Material:</b>	--

#### 4.2.3.7 [BSW02814] Confirmation depends upon selector field

<b>Initiator:</b>	Volkswagen / BMW
<b>Date:</b>	14.10.2005
<b>Short Description:</b>	Confirmation depends upon selector field
<b>Type:</b>	New
<b>Importance:</b>	High
<b>Description:</b>	On I-PDU Multiplexing the same I-PDU-ID is sent out with different signal layouts. This must be considered while implementing the confirmation handling. That is the confirmation given by the IpduM to the upper layer shall match the correct transmission request of the multiplexed I-PDU instance.
<b>Rationale:</b>	Ensure that confirmations are valid according to the selector field value. Since the confirmations of the underlying layer are given per multiplexed I-PDU the correct assignment of these confirmations to the multiplexed I-PDUs must be ensured by the IpduM.
<b>Use Case:</b>	--
<b>Dependencies:</b>	<a href="#">BSW02810</a> , <a href="#">BSW02813</a>
<b>Conflicts:</b>	--
<b>Supporting Material:</b>	--

#### 4.2.4 Shutdown Operation

Actual no special shutdown operations are required.

#### 4.2.5 Fault Operation

Actual no special fault operations are required.

### 4.3 Non-Functional Requirements (Qualities)

#### 4.3.1 Timing Requirements / Resource Usage

##### 4.3.1.1 [BSW02807] No Runtime Overhead for systems without I-PDU multiplexing

<b>Initiator:</b>	Volkswagen / BMW
<b>Date:</b>	22.09.05
<b>Short Description:</b>	The I-PDU Multiplexer module shall be designed in a way that no runtime-overhead shall exist for systems that do not require I-PDU-multiplexing.
<b>Type:</b>	New
<b>Importance:</b>	High
<b>Description:</b>	The I-PDU Multiplexer module shall be designed in a way that it does not produce any additional runtime compared to normal COM signal processing. To reach this goal it may be required to make I-PDU multiplexing a pre-compile time option. This assumption can be made if necessary.
<b>Rationale:</b>	Do not put additional load on systems that do not require I-PDU-multiplexing.
<b>Use Case:</b>	DC and Volvo do not plan to use I-PDU-multiplexing
<b>Dependencies:</b>	--
<b>Conflicts:</b>	--
<b>Supporting Material:</b>	--

### 4.4 Requirements to other modules

#### 4.4.1 Configuration of PduR

##### 4.4.1.1 [BSW02810] Routing of multiplexed I-PDUs on sender side

<b>Initiator:</b>	Volkswagen / BMW
<b>Date:</b>	14.10.2005
<b>Short Description:</b>	Routing of multiplexed I-PDUs on sender side
<b>Type:</b>	New
<b>Importance:</b>	High
<b>Description:</b>	The PduR shall be configured to send parts of multiplexed I-PDUs to the IPduM after they were received from COM on sender side.
<b>Rationale:</b>	Implementation of I-PDU multiplexing next to PduR.
<b>Use Case:</b>	--
<b>Dependencies:</b>	<a href="#">BSW02811</a> , <a href="#">BSW02814</a> , <a href="#">BSW02816</a>
<b>Conflicts:</b>	--
<b>Supporting Material:</b>	--



#### 4.4.1.2 [BSW02813] Routing of Send Confirmations

<b>Initiator:</b>	Volkswagen / BMW
<b>Date:</b>	04.11.2005
<b>Short Description:</b>	Confirmation handling of multiplexed I-PDUs
<b>Type:</b>	New
<b>Importance:</b>	High
<b>Description:</b>	The PduR shall be configured to send confirmations related to multiplexed I-PDUs to IPduM after receiving them from the lower layer.
<b>Rationale:</b>	Implementation of I-PDU multiplexing next to PduR.
<b>Use Case:</b>	--
<b>Dependencies:</b>	<a href="#">BSW02814</a> , <a href="#">BSW02816</a> , <a href="#">BSW02818</a>
<b>Conflicts:</b>	--
<b>Supporting Material:</b>	--

#### 4.4.1.3 [BSW02812] Routing of multiplexed I-PDUs on receiver side

<b>Initiator:</b>	Volkswagen / BMW
<b>Date:</b>	14.10.2005
<b>Short Description:</b>	Routing of multiplexed I-PDUs on receiver side
<b>Type:</b>	New
<b>Importance:</b>	High
<b>Description:</b>	The PduR shall be configured to send multiplexed I-PDUs for de-multiplexing to the IPduM after they were received from the lower layer.
<b>Rationale:</b>	Implementation of I-PDU multiplexing next to PduR.
<b>Use Case:</b>	--
<b>Dependencies:</b>	<a href="#">BSW02810</a>
<b>Conflicts:</b>	--
<b>Supporting Material:</b>	--

## 5 References

### 5.1 Deliverables of AUTOSAR

[DOC\_LAYERD\_ARCH] Layered Software Architecture  
[https://svn.autosar.org/repos/10Releases/  
AUTOSAR\\_LayeredSoftwareArchitecture.pdf](https://svn.autosar.org/repos/10Releases/AUTOSAR_LayeredSoftwareArchitecture.pdf)

[DOC\_SWS\_COM] Specification of Communication  
[https://svn.autosar.org/repos/10Releases/  
AUTOSAR\\_SWS\\_COM.pdf](https://svn.autosar.org/repos/10Releases/AUTOSAR_SWS_COM.pdf)